

Troubleshooting Manual



BATTERY LAWN MOWER 700 Series Parallel (Synchronized) 900 in Series High Voltage



1. Index

1. Index	1
2. Introduction	2
2.1 Electrical Components.....	2
2.1.1 HANDLE (Keypad and Controls)	3
2.1.2 POWER HEAD.....	4
3. Operating mode and controls	8
3.1.1 Keypad switching on	8
3.1.2 Eco Mode and LED button	8
3.1.3 OPC (Operator Presence Control).....	8
3.1.4 Feed Speed Lever.....	8
4. Disassembly of the Power Head's components	9
4.1 Removal of the Electrical Motor.....	9
4.2 Disassembly of "Power Head" covers.....	10
4.3 Removal of the Electronic Card (PCB)	12
5. Electrical Troubleshooting	14
5.1 Troubleshooting – Diagnostic Tool	14
5.1.1 Use, Connections and Diagnostic.....	14
5.1.2 Missing signal of Diagnostic Tool	14
5.2 Troubleshooting (machine).....	15
5.3 Troubleshooting (BATTERY and CHARGER)	18
6. Electronic system architecture	19
6.1 Printed Circuit Board (PCB): POWER HEAD	19
6.2 KEYPAD (Handle)	20
6.3 Tilt sensor (Only 900 series).....	21
6.4 Anti-spark microswitch (900 series only)	21
7. Operating check of electrical components (Handlebar Switch, PCB, Battery, Motors...)	22
7.1 Operating check of handlebar electrical components	22
7.1.1 OPC microswitch.....	23
7.1.2 Keypad switching on	23
7.2 Operating check of POWERHEAD electrical components	24
7.2.1 Main PCB POWER HEAD.....	24
7.2.2 Traction PCB and Traction Motor	25
7.3 Battery TEST	26
8. Wiring Diagram	27



2. Introduction

This Manual deals with the problems and checks connected with the electrical system. All work can be done using a tester without having to use special equipment.

The electrical diagrams can be useful to you for understanding how the system works and to facilitate the pinpointing of any problems.

Faulty electronic cards, batteries and battery chargers must always be replaced without trying to repair them or replace single components

2.1 Electrical Components

General informations:

We can divide electric components into 3 main groups:

- Handlebar (DISPLAY and controls);
- POWER HEAD;
- Electric Traction

This section details the position of the electrical components

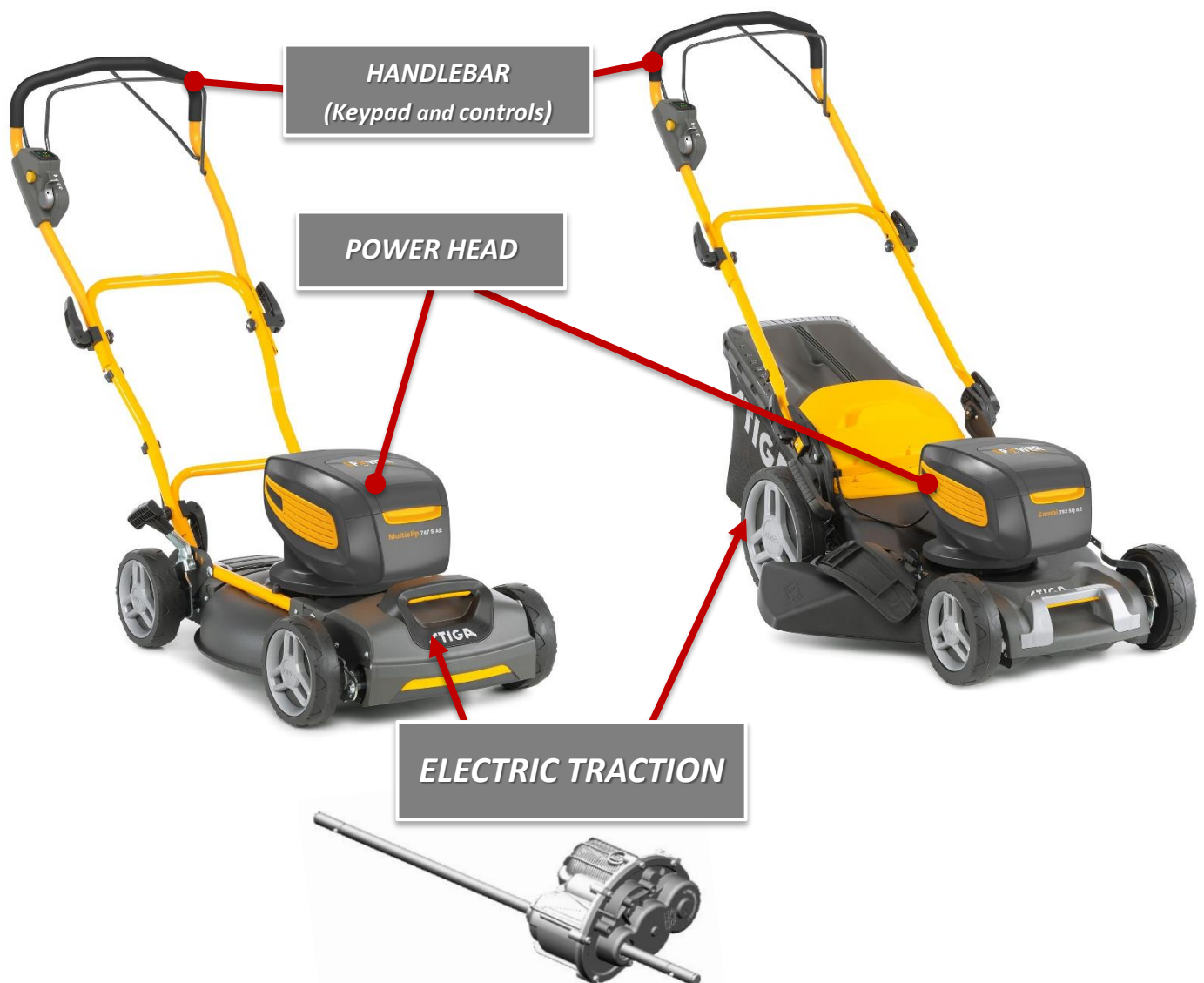



2.1.1 HANDLE (Keypad and Controls)

The handle of lawn mower is equipped with a display having an electronic circuit board inside, including the Operator Presence Control safety logic (OPC). Also: the controls of the electric traction, the “ECO mode” button and the power button of the keypad are integrated. Display shows the level of battery charging.





2.1.2 POWER HEAD

The element named “**POWER HEAD**” consists of three main components: Battery, Motor and Printed Circuit Board (PCB).





LOWER SIDE

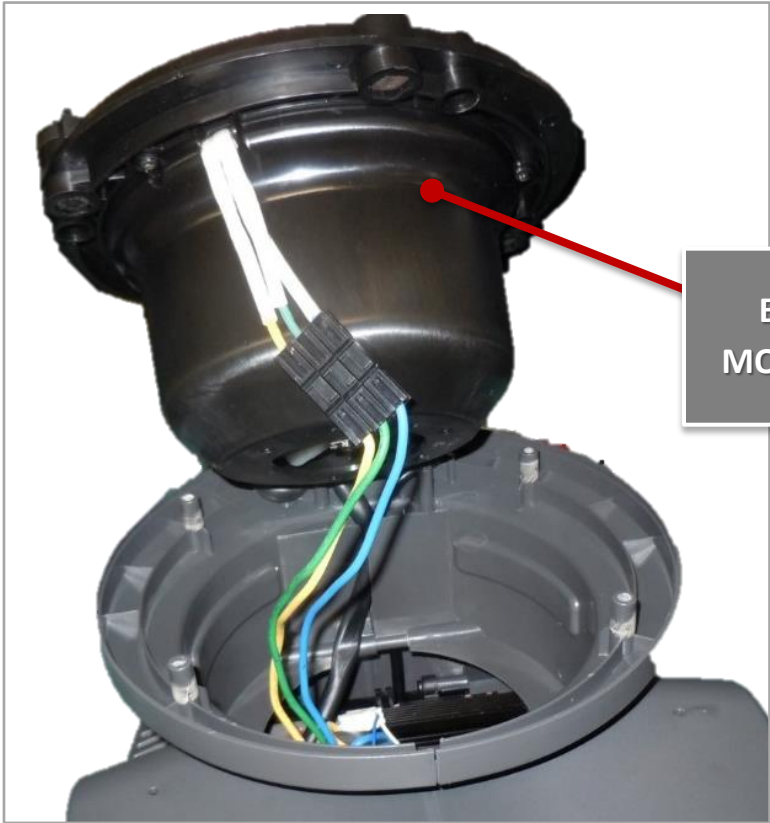

**ELECTRICAL
MOTOR (BLADE)**

NOTE: pictures below show **“700 Series”** version

VIEW FROM BELOW

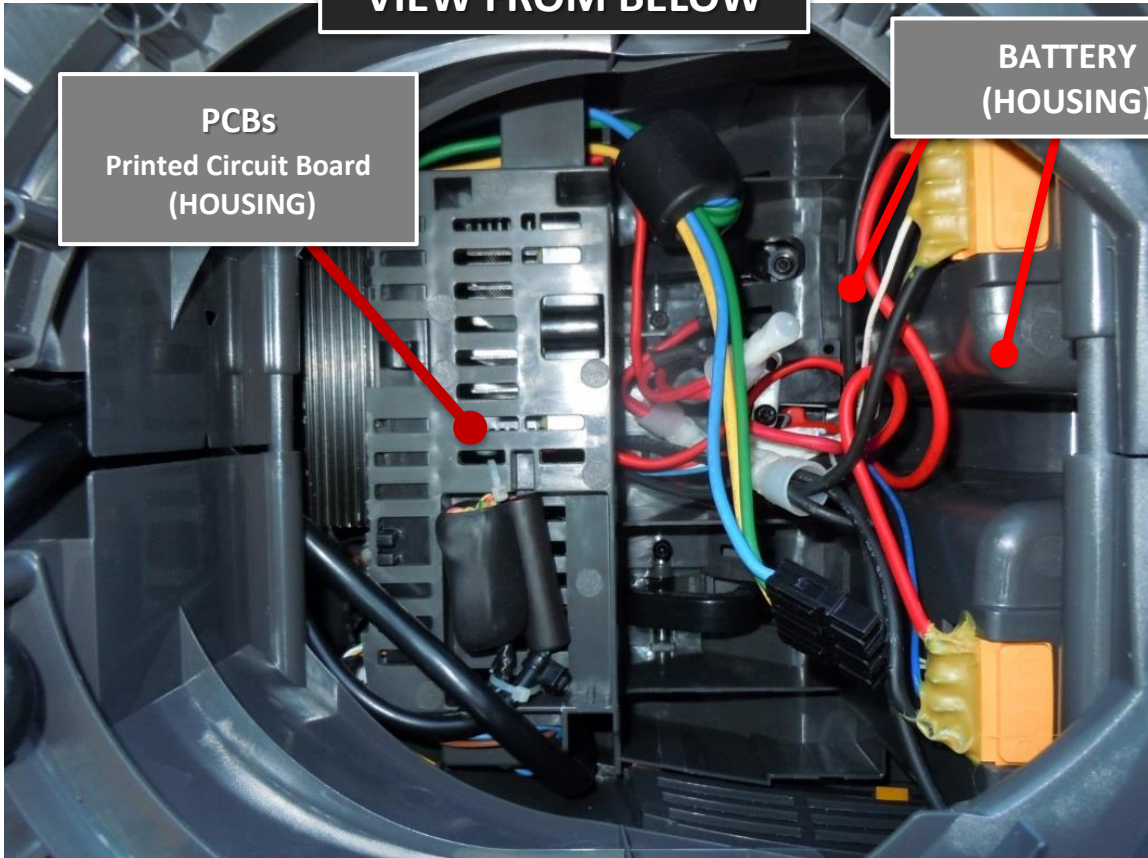

**PCBs
Printed Circuit Board
(HOUSING)**

**BATTERY
(HOUSING)**



UPPER VIEW

PCB
Printed Circuit Board
TRACTION

PCB
Printed Circuit Board
Parallel

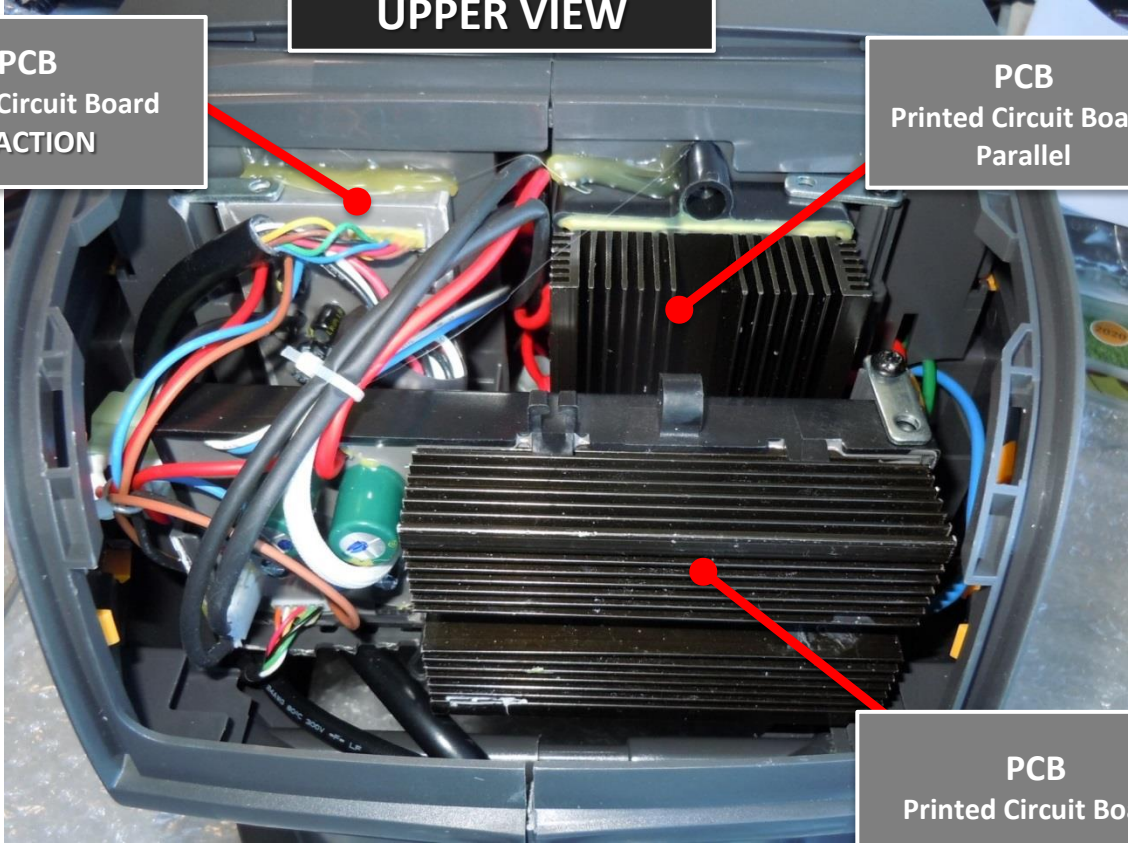

PCB
Printed Circuit Board

VIEW without covers

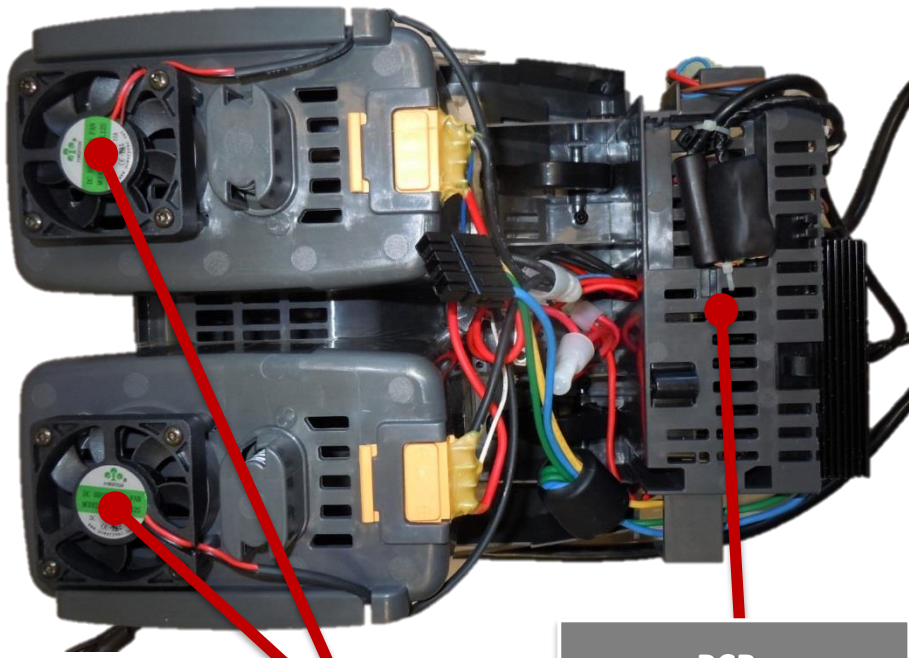

FANS

PCBs
Printed Circuit Board
(HOUSING)



**ELECTRONIC CARDS
(PCB)**

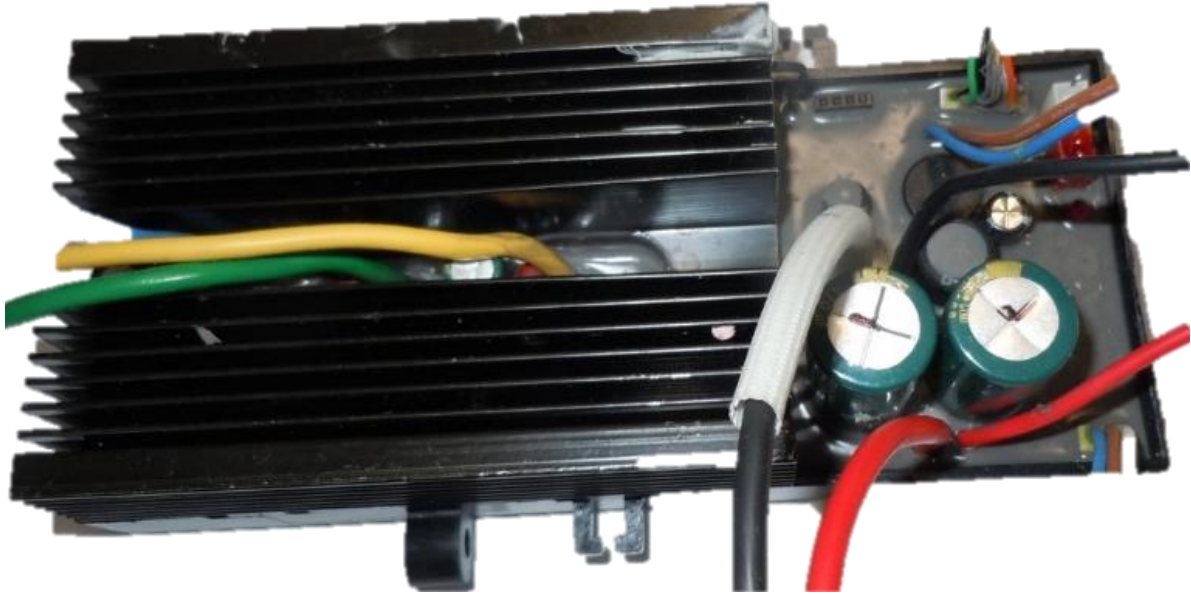

**ELECTRONIC CARDS (PCB)
PCB Cables, Connectors and Components**

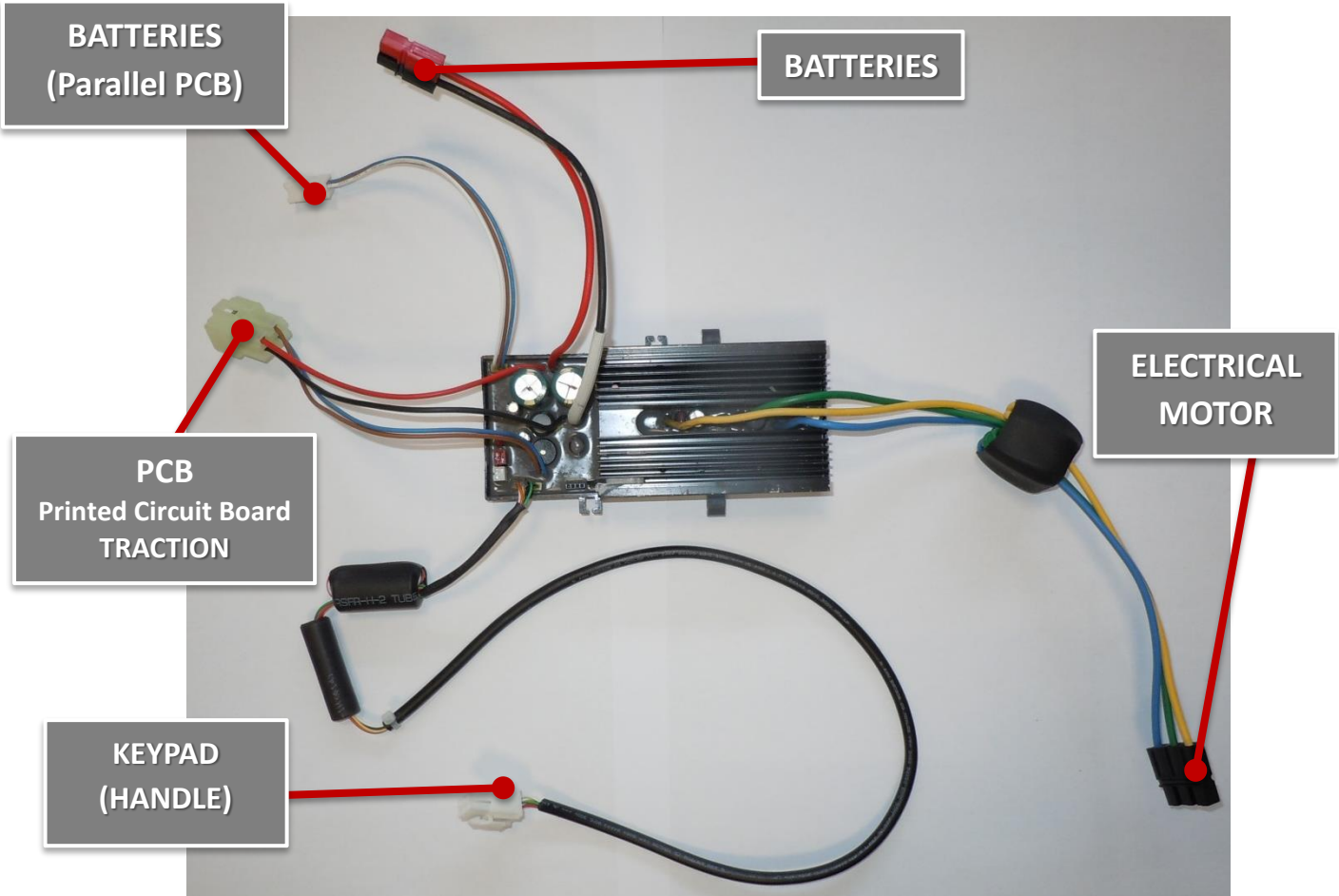



3. Operating mode and controls

As anticipated before (*See 2.1.1 HANDLE (Keypad and Controls)*) all controls for starting and grass cutting are on the handle. You can find main instructions for controls use as follows but regarding specific use of machine please refer to owner's manual provided.

3.1.1 Keypad switching on

This button **(1)** is used to:

- Turn on the machine only if the OPC lever is not engaged;
- It is possible to turn off the blade motor by pressing the power button of the keypad so that the blade stops without switching off the machine

Once the operator presses the power button the machine is reactivated (only if OPC is not enabled). When the machine is switched on, the "power on" LED lights up. If OPC lever is released, the machine switches off after a timeout. If the POWER button is pressed when the machine is on, the machine switches off.

3.1.2 Eco Mode and LED button

Powerhead is equipped with Brushless Motor (1500W for 700 series and 2200W for 900 series). By pushing the "Eco Mode" button **(2)** the cutting motor is set at lower speed for energy saving purpose.

Another push for restoring the standard speed.

When the "ECO mode" is activated a LED lights up.

"ECO mode" is deactivated each time the OPC is released.



3.1.3 OPC (Operator Presence Control)

The Operator Presence Control (OPC) is a safety system that enable the activation of motors only if at least one operator hand is on the handlebar.

It is created by a lever **(3)** linked to a switch through a mechanism. If the OPC switch is closed, the blade motor runs but, to make it effective, the operator has to press the START button **(4)** before pulling the OPC lever **(3)**.

3.1.4 Feed Speed Lever

The traction motor speed can be selected on the handlebar by control Knob **(5)**.

Different speed levels are available, from the minimum to the maximum one (zero speed is not available).

Once the operator selects the traction speed, the traction motor is enabled by pushing the TRACTION ACTIVATION LEVER **(6)**.

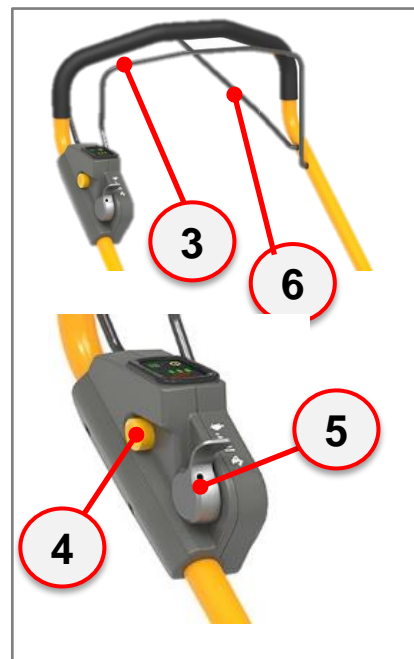

When the "Enable Traction" switch is turned ON, the traction motor runs at the last speed was selected. The traction can work even if the blade motor is OFF



4. Disassembly of the Power Head's components

Here below you can find some indications useful for removal of electrical motor and plastic covers of "Power Head".

4.1 Removal of the Electrical Motor

Remove the Power Head from the machine.

Unscrew the six screws (1) and remove the Motor support (2) from **Power Head**

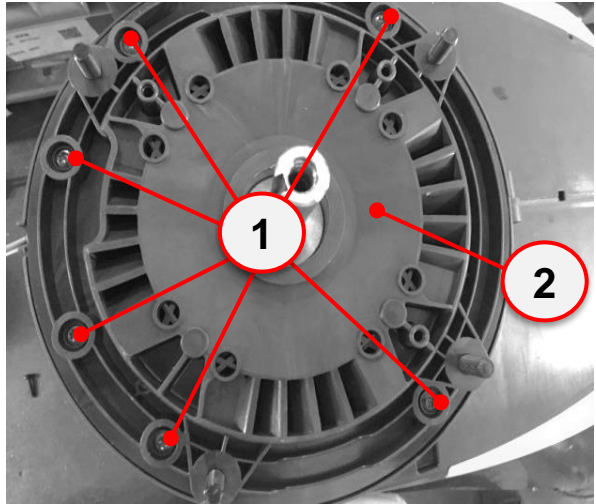

Disconnect the three phase line connector (3).

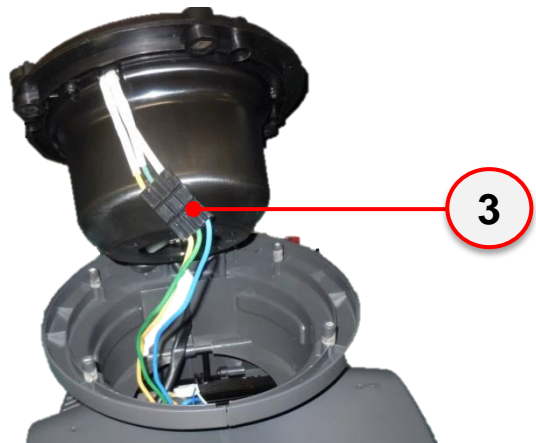

Unscrew the three screws (4) and remove the Motor conveyor (5).

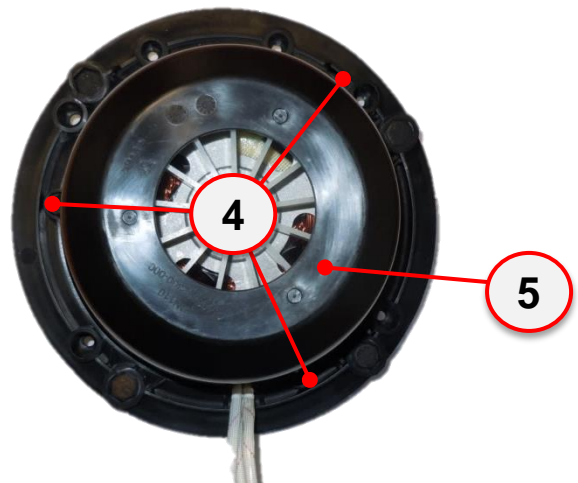



Unscrew the three screws (4) and remove the Motor conveyor (5).

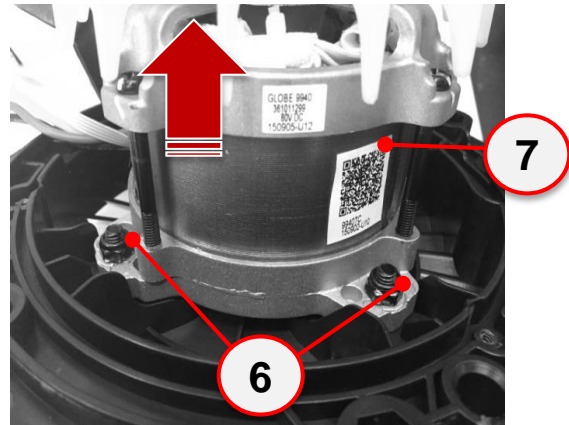
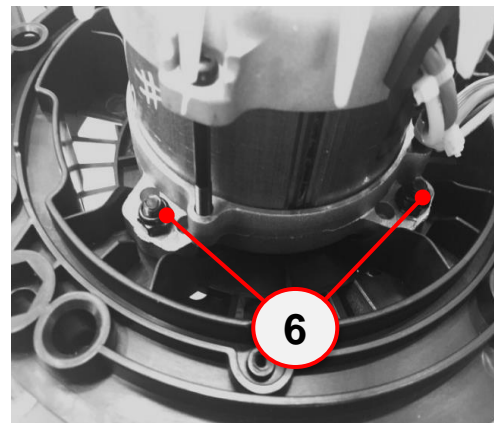

4.2 Disassembly of "Power Head" covers

The disassembly of covers lets reach PCB and main connections with other electrical components: battery, electric motor and handlebar (Keypad and controls); and allows to perform some of troubleshooting procedures described on following chapters (*see chpt. 5 and 7*).

Remove the Power Head from the machine.

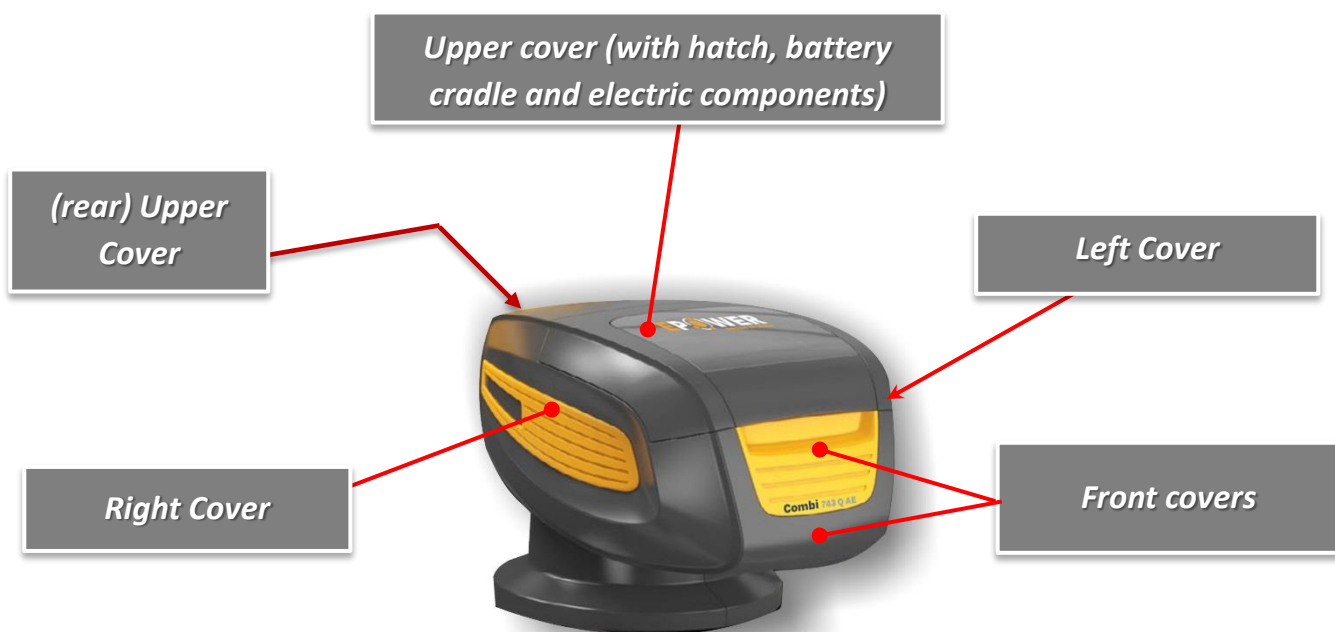



Here below some pictures highlighting the different fixing points of **Power Head** covers.

1. Remove the motor (See *chpt. 4.1*).
 2. Remove the rear and front covers.
- The side covers (right and left) are fixed through 6 points (see different fixing points in the picture).

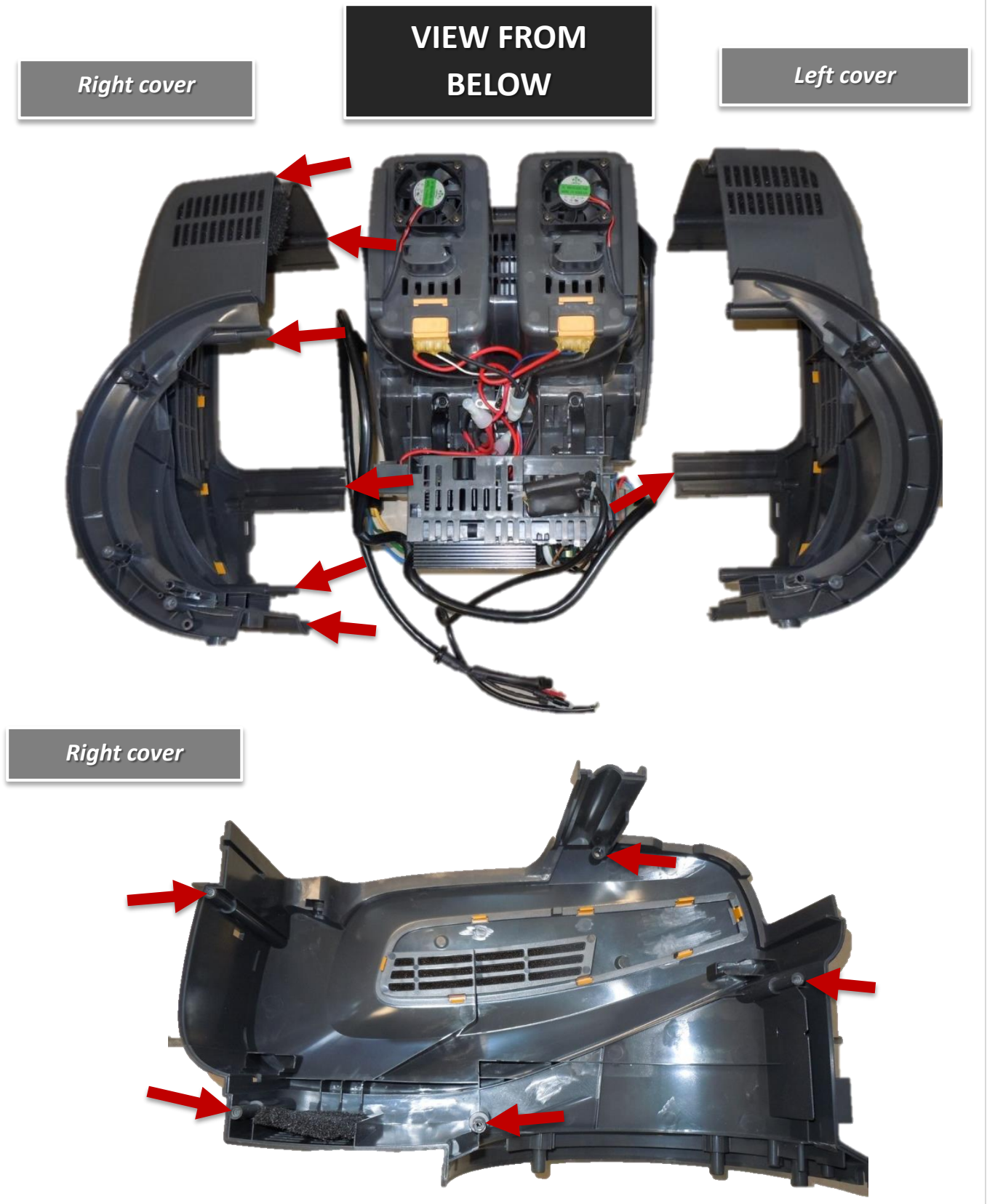



NOTE: as regards the removal of **PCBs** please refer to [4.3 Removal of the Electronic Card \(PCB\)](#)

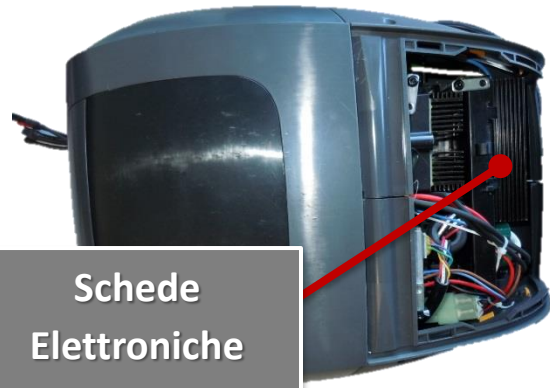

4.3 Removal of the Electronic Card (PCB)

NOTE: pictures below show **"700 Series"** version.

Remove the rear cover.

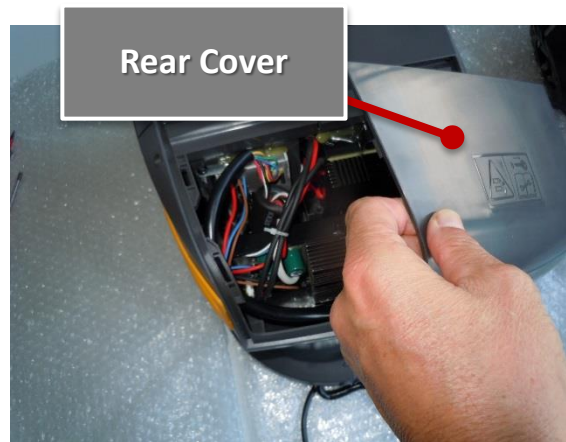

Loosen the screw (1) and turn the metal plate (2) to make the controller (**PCB**) and the parallel PCB accessible.

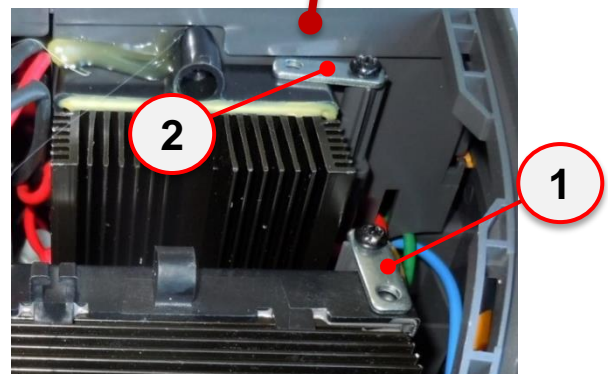
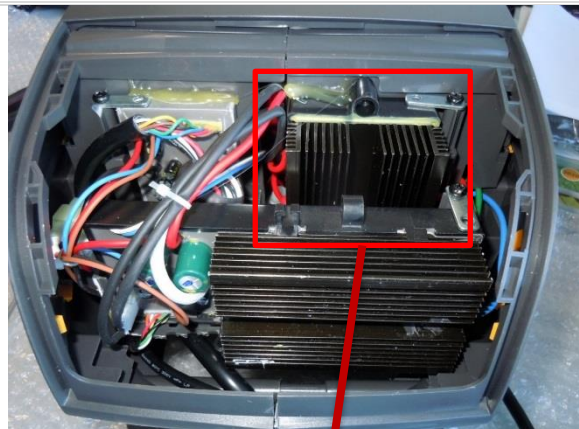



Remove the Motor ([See chpt.4.1](#)).

IMPORTANT: before making following operations it is advisable to observe / memorize the positioning and the cables path; this will make assembly operation easier.

To remove the PCBs, it is advisable to remove the various cable ties holding the cables together and disconnect the various connectors (battery, parallel PCB, fans, etc.).

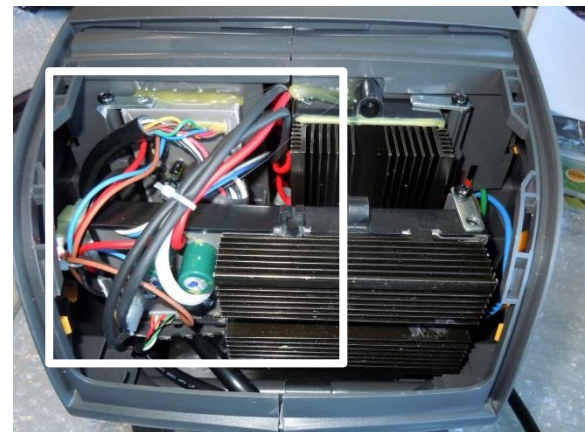
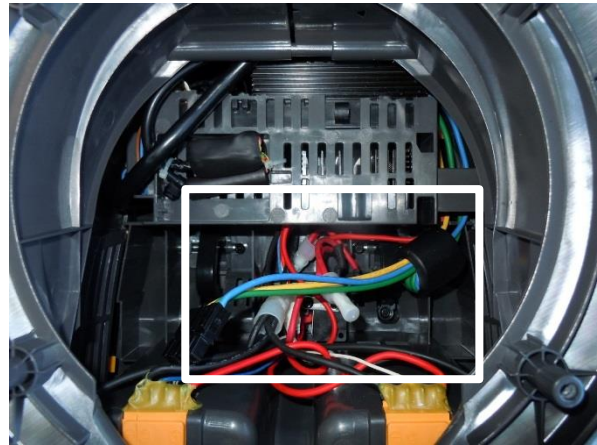

IMPORTANT: before making following operations it is advisable to observe / memorize the positioning and the cables path; this will make assembly operation easier.

To make the removal of PCBs and other installed component (traction PCB, fans, ...) easier and disconnect the various connectors, it is recommended to remove the right and left side covers.

All electric and electronic components are fixed on the upper cover/battery cradle.





5. Electrical Troubleshooting

In the following some of the problems connected to the malfunctioning of the electrical system are shown, with their probable cause and the remedial action to be taken.

5.1 Troubleshooting – Diagnostic Tool

General informations:

As regards “TT 500 Synchronized” range of machines, STIGA provided the possibility to use a DIAGNOSTIC TOOL.

The Diagnostic Tool supports connection both to appliance and battery with the main purpose of assisting you with the troubleshooting in case of malfunction of the machine (Battery or Appliance).

The Diagnostic Tool for the 48V lithium-ION rechargeable battery system is composed by the following parts::



2. Hardware Diagnostic Tool SDT500;
(A) Main electronic and battery cradle;
(B) Fake battery
3. Software to be installed on Windows OS

5.1.1 Use, Connections and Diagnostic

Please refer to Diagnostic Tool manual that you can download together with the software on our STIGA Connect portal:

<https://stiga.ev-portal.com/Login/Stiga>

5.1.2 Missing signal of Diagnostic Tool

- Check that the contact on the battery and the contact of the battery on the machine are intact and clean;
- Check the correct positioning of Fake Battery (B)”;
- Check the correct positioning of feeding Battery (A)
- Try to replace the battery;
- Check that USB cables of Diagnostic Tool are intact and clean;
- Perform checks indicated in the following paragraphs 5.2 and the chapter 7





5.2 Troubleshooting (machine)

A problem solving session is proposed besides throubleshoot using the Diagnostic Tool.

General information

This chapter deals with the problems connected to the malfunctioning of the machine and with their probable cause and the remedial action to be taken.

The owner's manual already gives a basic troubleshooting guide to help out the user in solving the most common possible malfunctions.

The printed circuit board (PCB) has a LED  with various flashing sequences and has an acoustic alarm (buzzer)  with various intermittent sequences. These two devices (LED + buzzer) provide useful indications to recognise failures on the electric system.

Alarm BUZZER (BIP) string configuration:



Nr.	"BIPS" STRING	CAUSE
1	3/cycle	Over current
2	5/cycle	Overheating (Power Head or battery)
3	4/ciclo	Overheating of traction Motor
4	6/ciclo	Overload current of traction Motor
5	2/cycle	Others failures

Note: cycle means the number of close "Bips" cyclically repeated. Example: 3/cycle means 3 close Bips, short pause, 3 close Bips and so on.

LED Flash String configuration:

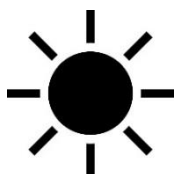

Nr.	FLASH STRING	CAUSE
1	1/cycle	The PCB self-checking failed
2	2/cycle	Overheating of traction Motor
3	3/cycle	The communication between PCB and battery pack failed
4	4/cycle	Over current protection
5	5/cycle	Low voltage protection
6	6/cycle	PCB or battery overheating protection
7	7/cycle	Communication error between controller (PCB and PCB's Traction
8	8/cycle	Locked-rotor protection
9	9/cycle	Over current on traction
10	STILL	Communication error between controller (PCB) and handle (keypad).

Note : cycle means the number of close flashings cyclically repeated. Example: 3/cycle means 3 close flashings, short pause, 3 close flashings and so on.



To make detecting errors easier and avoid the disassembly of the **POWER HEAD** covers to get access to the controller (**PCB**) it was decided to report the error on the keypad of the machine thanks to the battery LEDS bar (1) and the defect warning LED (2).



The combination between error code on Keypad and buzzer beep can provide to the user/dealer the information about the problem without opening the POWER HEAD (see Troubleshooting table below)

KEYPAD OFF			
CYCLE		PROBABLE CAUSE	REMEDY
	Keypad		
-	OFF	The safety switch is in OFF position in the battery cradle.	Move the switch in ON position.
		Battery is not inserted or is inserted incorrectly	Open the hatch and check that the battery is fitted into its housing correctly.
		Wrong starting procedure	Press the power button.
		Handle Bar micro switch not connected and/ or damaged	<ul style="list-style-type: none"> • Make sure the Handle Bar Switch connectors are properly assembled, dry if necessary, not damaged and free from corrosion (See 7.1). • Sostituire il microinterruttore danneggiato.
		Handle bar (Keypad/Controls) or POWER HEAD Connectors not correctly assembled.	Check if connectors are undamaged and correctly assembled.
		Short Circuit in PCB (handle bar or POWER HEAD).	Check PCB and replace if required. (see 7.2.1 Main PCB POWER HEAD)



“BIP” STRING + Information on KEYPAD

CYCLE							PROBABLE CAUSE	REMEDY
Speaker	Sun	KEYPAD						
		1	2	3	4	5		
2	5	LAMP.	LAMP.	LAMP.	LAMP.	ON	Low Battery (or Batteries)	Check the battery (Batteries) status and recharge if necessary.
	3	-	-	ON	ON	ON	Battery communication fault	See 5.3 Troubleshooting (BATTERY and CHARGER)
	8	ON	-	-	-	ON	Locked rotor blade	Remove obstruction that prevent rotation of the cutting device.
							Missing motor connection	Check that motor connector is correctly connected to PCB
						Motor rotation detector (PCB) failure.	Replace the Electric Motor (See 4.1)	
5	6		ON	ON	-	LAMP.	The thermal protection has tripped due to overheating of the motors, the PCB or the Batteries	Wait for at least 5 minutes and then restart.
3	4		ON	-	-	ON	Current Sensor has tripped due to excessive current absorption caused by: <ul style="list-style-type: none"> excessively high grass cutting obstructions that prevent rotation of the cutting means too much grass debris accumulated in the chassis and discharge channel 	<ul style="list-style-type: none"> Set a higher cutting height when the grass is very tall, then set a lower height and cut the lawn again. Remove the obstructions. Clean the machine. Wait for at least 5 minutes and then restart the machine.
2	1	-	-	-	ON	ON	Auto check fail.	<ul style="list-style-type: none"> Check electric connection among components Internal issue of PCB: check a replacing PCB, if necessary.
3	7	-	ON	ON	ON	ON	Phase line of traction motor disconnected and/or traction PCB wiring damaged..	Check the traction wiring and the connectors of motor phase line. Replace the traction PCB.
2	7	-	ON	ON	ON	ON	Motor (traction) rotation detector (PCB) not connected to PCB.	Make sure the traction motor rotation detector connector is correctly connected to the PCB
							Motor rotation detector (PCB) failure.	Replace the Electric Motor (See 4.1)
6	9	ON	-	-	ON	ON	Over current protection	<ul style="list-style-type: none"> Remove obstructions from wheels Check working conditions. Excessive slope (>15%)
4	2	-	-	ON		LAMP.	Traction overheating protection	Wait for at least 5 minutes and then restart.
2	STILL	-	-	-	-	ON	Communication error between controller (PCB) and handle (keypad).	Check the integrity of cables connecting the keypad to main controller (PCB)



- PCB's Buzzer and LED (Power Head)

1 2 3 4 Battery LEDS bar (1)

Defect warning LED (2)

LAMP.
LAMP. Flashing





5.3 Troubleshooting (BATTERY and CHARGER)

General informations:

This chapter deals with the problems connected to the malfunctioning of BATTERY & BATTERY CHARGER and with their probable cause and the remedial action to be taken.

The Operator's Manual of BATTERY & BATTERY CHARGER already include most of common possible malfunctions highlighted in this table.

ROBLEM	PROBABLE CAUSE	REMEDY
No LED's light up on battery when pressing the status button	Low Battery	Recharge immediately the battery
	Faulty battery (See par 7.3.)	Replace battery.
The battery charger is not recharging the battery (NO LEDs on the charger are shown when battery is inserted)	Bad connection between charger and battery	Check it is correctly inserted. Make sure power connectors between charger and battery are not damaged and free from dirt.
	The battery charger is not energized	Check it is plugged in and the power socket is energized
	Faulty battery charger	Disconnect charger from power socket for >1 min then reconnect it to power socket. Make sure the fan and the green LED lights up. If not, replace with an original spare part.
Solid Red LED on charger when battery is inserted.	Battery out of temperature range	Make sure ambient temperature is between 7 °C and 40°C.
Flashing red LED on charger when battery is inserted.	Bad connection between charger and battery	Check it is correctly inserted. Make sure power connectors between charger and battery are not damaged and free from dirt.
	Faulty battery (See par 7.3.)	Replace battery.
	Broken charger	Disconnect charger from mains for >1 min. then reconnect to mains outlet. Make sure the fan and the green LED lights up. If not, replace with an original spare part.
Green LED on charger for approx. 5-15 seconds when battery is inserted, thereafter flashing red LED. The behaviour then repeats from the beginning.	Faulty battery	Place the battery in a functioning charger . If same problem occurs replace battery.
	Broken charger	Place a functioning battery in the charger. If same problem occurs, replace charger.



6. Electronic system architecture

Before proceeding to the analysis of the problems related to the malfunctioning of the electrical system and the testing of the various electrical components, below a brief explanation of the operating logic of system and software installed on the PCB of the POWER HEAD..

6.1 Printed Circuit Board (PCB): POWER HEAD

The two Powerhead series 700 and 900 have different system architecture.

The controller (PCB) manages the following interfaces:

- • Battery: power supply and communication
- • Wires communication with New Advanced Handlebar
- • Blade Brushless motor
- • Traction controller (PCB)
- • Led
- • Buzzer
- • Built in Tilt sensor (for 900 series only)
- • 12V Battery cooling FAN powered by main controller

- Dual-Battery 700 Series

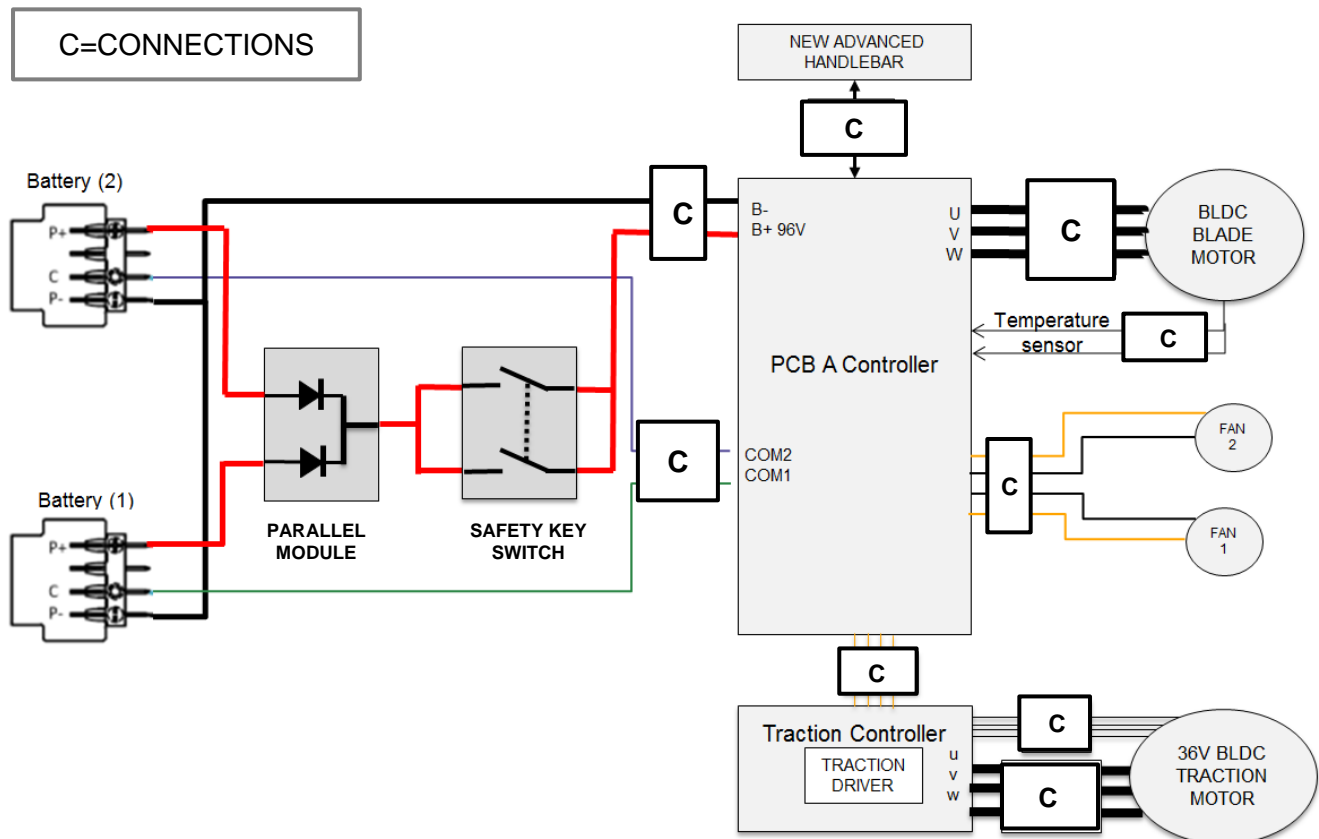



- Dual-Battery 900 Series

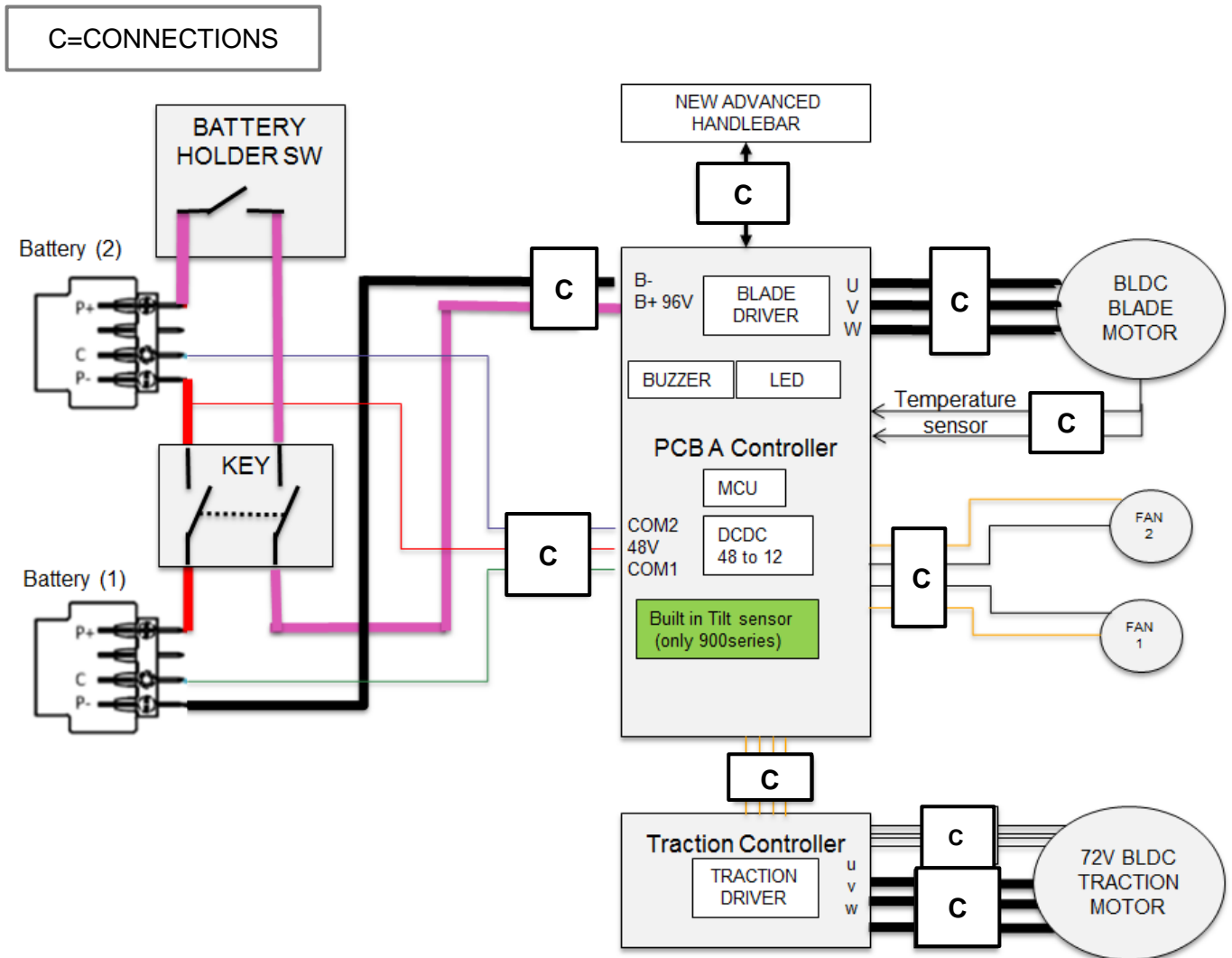

44

6.2 KEYPAD (Handle)

For both 700-900 series, the main controller must comply with following features:

- PH is responsible to communicate with Advanced Handlebar with bidirectional 1 wire communication.
- PH is responsible to read the status of “OPC switch”, “TRACTION switch”, “Power button”. These signals are directly connected to the PH.
- PH has to supply the handlebar.
- PH implements the control logic strategy “
- PH checks the integrity of POWER, TRACTION, and OPC switches each time the operator turns ON the lawn mower.

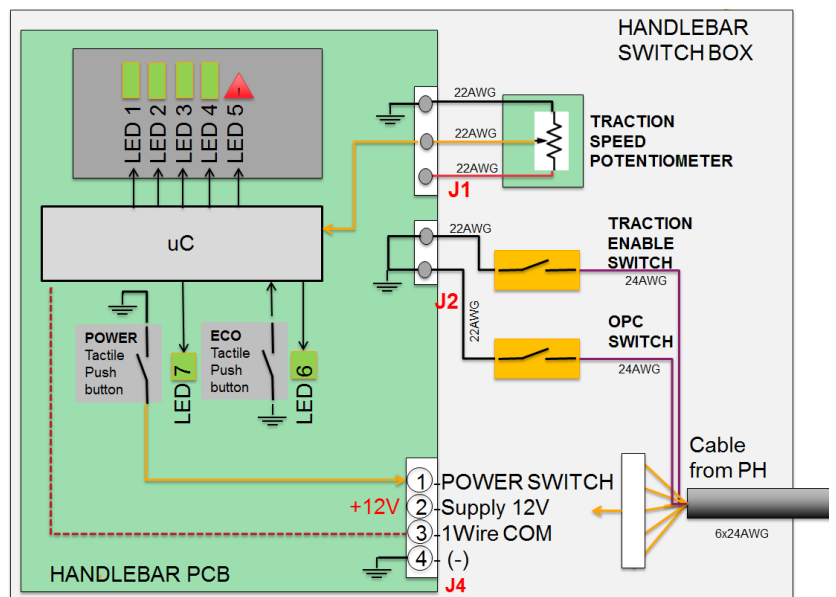



6.3 Tilt sensor (Only 900 series)

On 900 series main controller (PCB) is installed an accelerometer as tilt sensor.

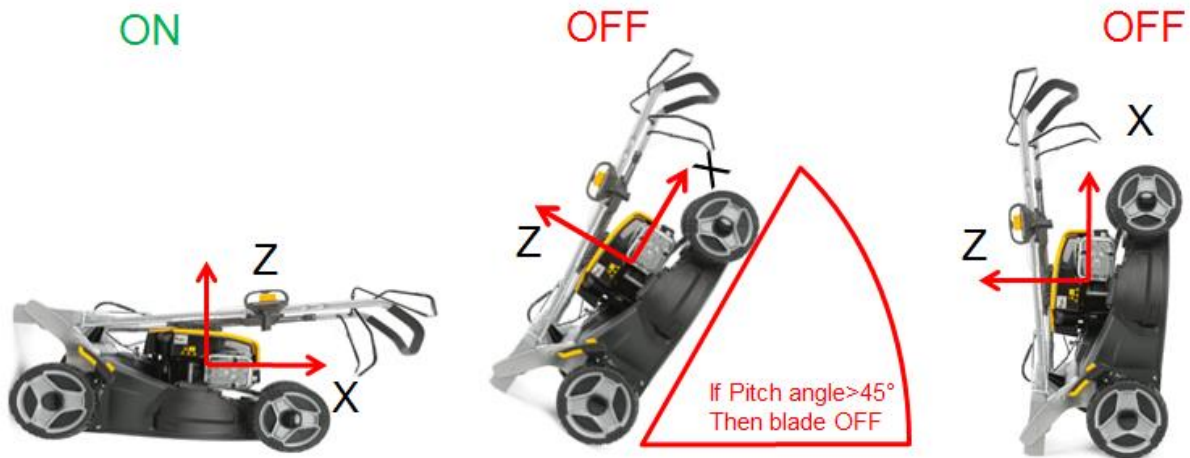

The tilt sensor is necessary just to avoid to switch on the machine when it is in vertical (static) STORAGE position, not during dynamic working time as inclinometer warning.

6.4 Anti-spark microswitch (900 series only)

Even if battery packs are removed from PH, a residual energy remains inside controller (PCB) capacitors. In order to avoid that operator reaches the live contacts with hands an additional structure is implemented. Under the battery holder of battery 2 (with higher voltage) a switch disconnects the positive pole P+ of battery contact from main PCB when the battery is removed.

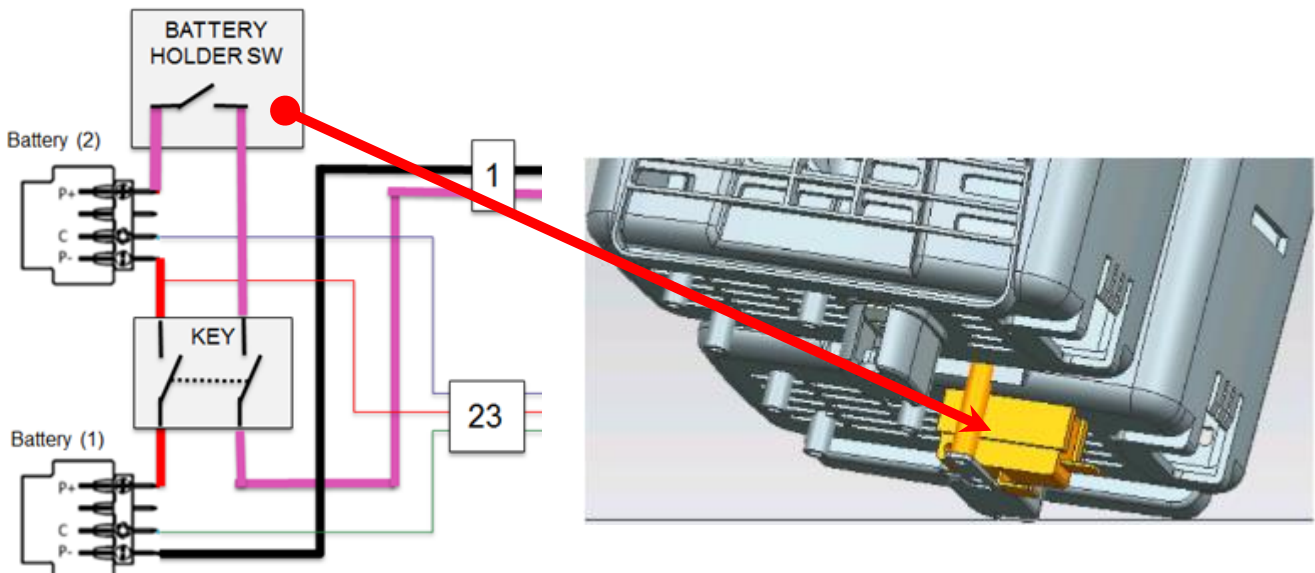

In order to prevent the sparks during battery insertion, due to inrush current of the controller (PCB) capacitor, a pre-charge circuit is implemented on main controller (PCB).



7. Operating check of electrical components (Handlebar Switch, PCB, Battery, Motors...)

This section completes and develops the previous one “5 Electrical Troubleshooting”.

The purpose is to provide a step by step guide to identify faulty components avoiding the disassembly of the entire machine.

All checks can be done with a multimeter without need of special equipments.

7.1 Operating check of handlebar electrical components

This check has to be performed in the connection between the handlebar cable and that one coming out from the POWER HEAD (**Pic.3**) which is located in the connector case (**part. 1 on pic. 1**).

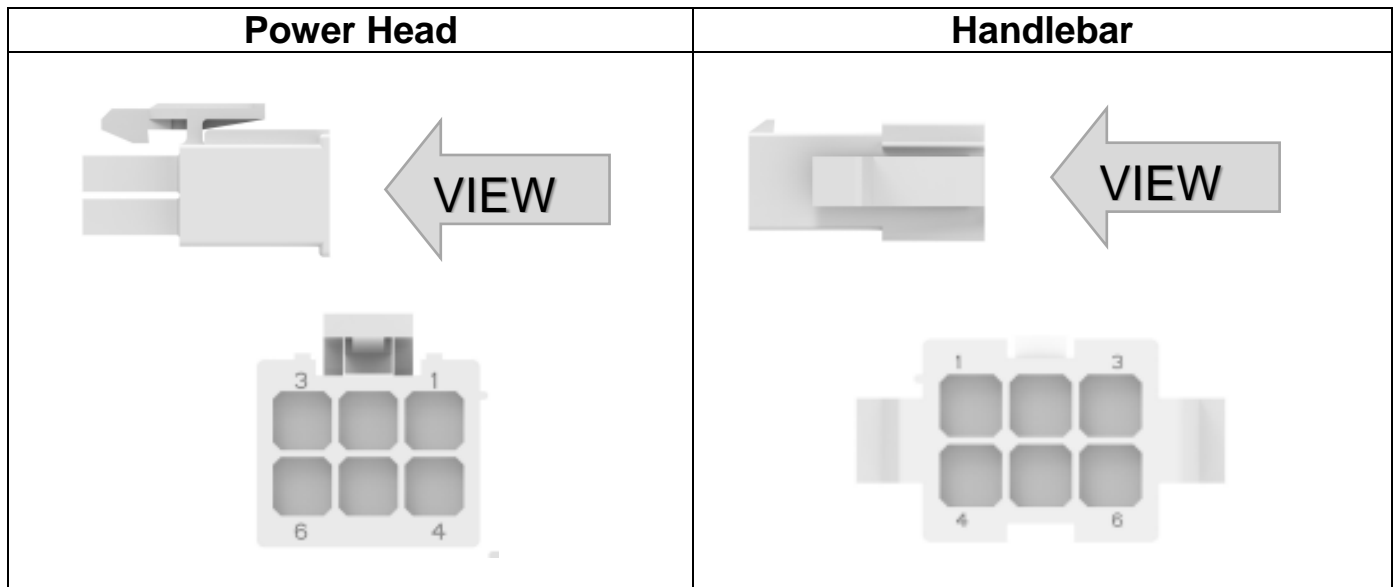
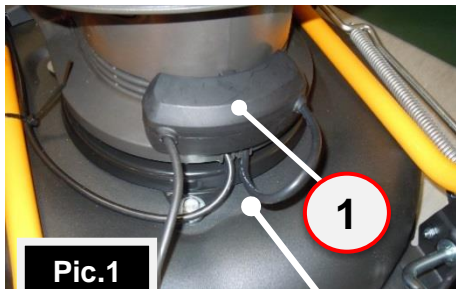

PIN	Signal	Color
1	VCC 12V	RED
2	TRACTION	ORANGE
3	GND	BLACK
4	COM	GREEN
5	Power sw	YELLOW
6	OPC Switch	WHITE



7.1.1 OPC microswitch

NOTE: Before proceeding with following electrical test, please verify the correct functioning of the handlebar lever activating the microswitch. Engaging the lever you have to hear the "CLICK" of the microswitch

- Unplug connectors 1 and 2
- Test performed in the handle connector with multimeter in Ohmmeter function should give following results:

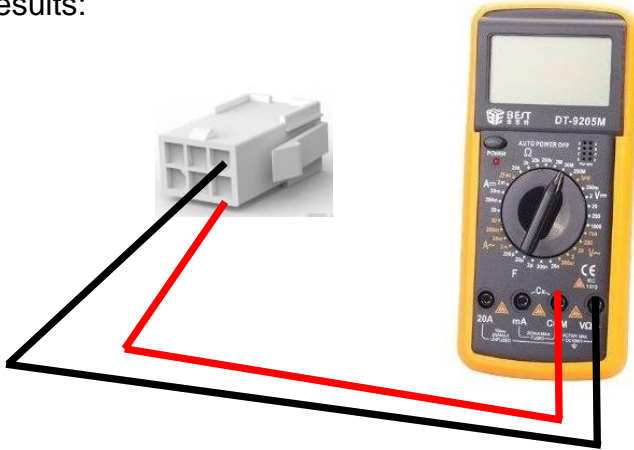

CONTACTS	TESTER READING AND HANDLE BAR SWITCH CONDITION (ON/OFF)	
6 – 3	∞ (Released)	0 (Pressed)

If the values **do not** comply with the table above, make sure that the electric cable is not damaged and check the integrity of the handlebar switch

7.1.2 Keypad switching on

- Unplug connectors 1 and 2
- Test performed in the handle connector with multimeter in Ohmmeter function should give following results:

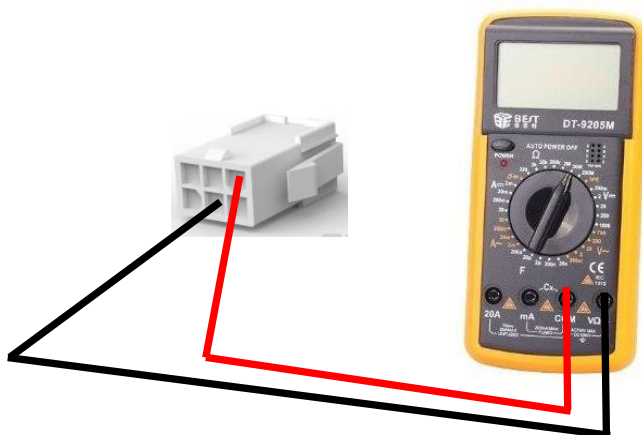

CONTACTS	TESTER READING AND BUTTON CONDITION (ON/OFF)	
3 – 5	∞ (Released)	0 (Pressed)

If the measured value does not comply with the table above, the Keypad has to be replaced.



7.2 Operating check of POWERHEAD electrical components

Before disassembling and checking the electrical components of the POWER HEAD, it's recommended to check the **12V**. that the POWER HEAD PCB must always guarantee through **the PIN "3"** is recommended. Perform checks (*see 7.2.1 Main PCB POWER HEAD*)

7.2.1 Main PCB POWER HEAD

This test has to be performed on connection between Handlebar connector and POWERHEAD connector you can find in "connectors case".

To perform this checks connectors 1 and 2 have to be connected (check connection):

- Set the Battery and put the safety switch in the ON position;
- Push the Keypad switching on
- Test performed in the POWER HEAD connector with multimeter in Voltmeter should give following results:

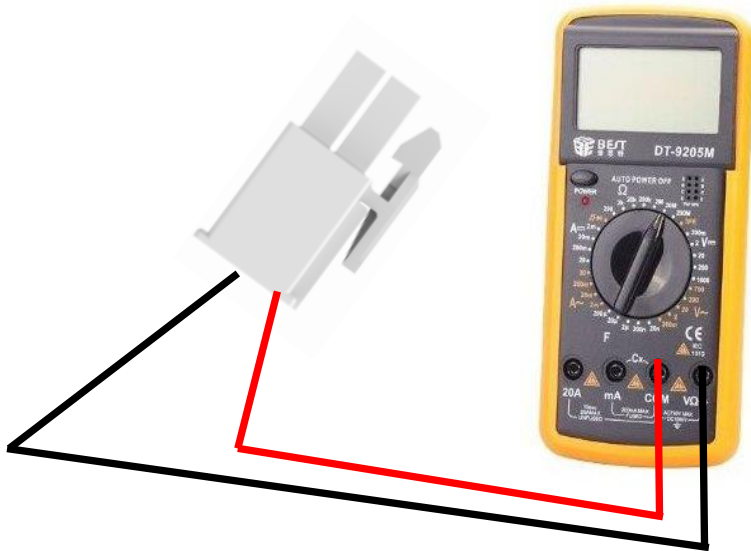

CONTACTS	TESTER READING	
3 – 1	12V (PCB OK)	0V (PCB Damaged)

NOTE: If test gives negative result, check connection between POWERHEAD and PCB



7.2.2 Traction PCB and Traction Motor

Check can be performed with battery fitted and safety switch in ON position)

The check must be done by disconnecting the (connecting) terminal of the signal cable that arrives at the traction motor:

1. remove the traction covers of lawnmower (different according to the model); In some cases motor may have to be removed, but has to remain connected anyhow;
2. remove connector (**part 1, pic. 1**) on traction motor.
3. With multimeter in Volt function check values on connector (**part.1, pic.2**)



ATTENTION: *The connector contacts are small, use a tester with special end sleeves avoiding to force and damage the terminals.*

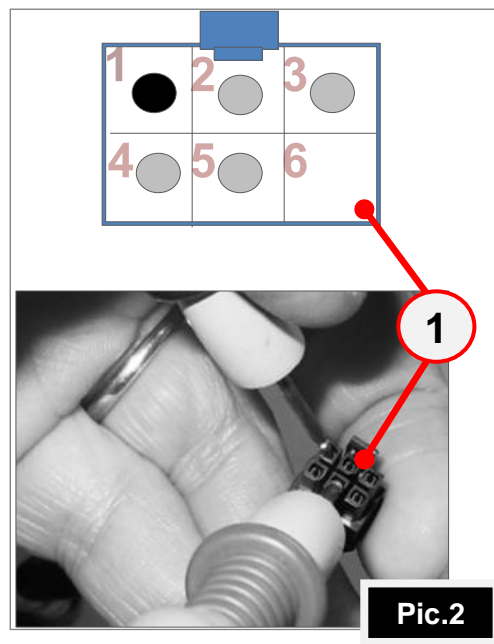
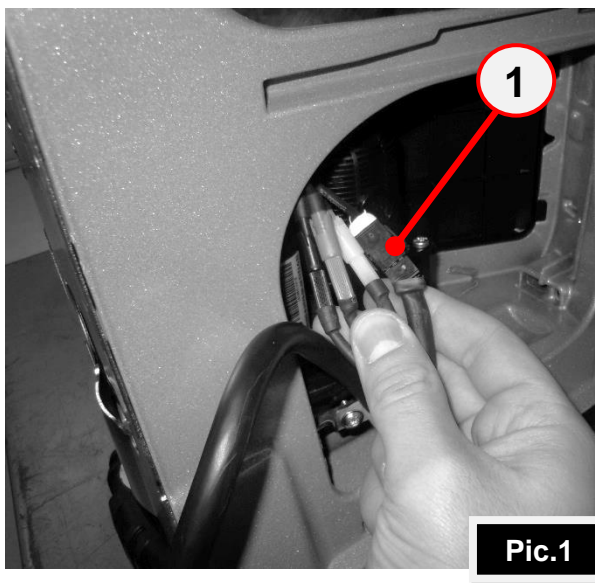

On all TESTS:

- 1 → 2
- 1 → 3
- 1 → 4
- 1 → 5

The value must be 3.3V.

In case of checks above do not reveal any error, it is recommended to replace the drive motor.

IMPORTANT: before replacing the motor, it is recommended to check all cables in order to detect any possible disconnection.

NOTE: Check has to be done on cold traction motor



7.3 Battery TEST

In the event that the battery can not be recharged it is recommended to perform the following check with the multimeter.

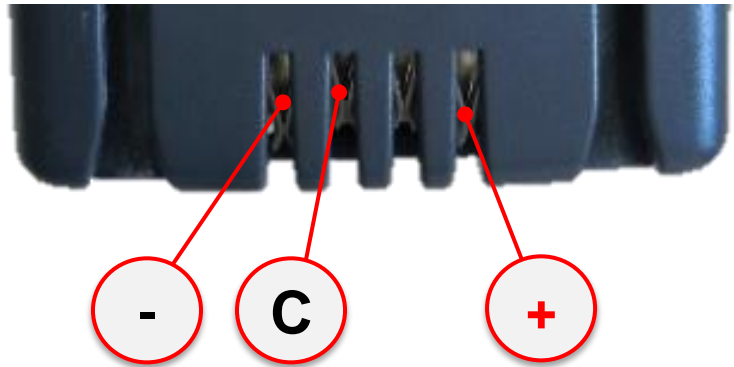

1. Measure the impedance with multimeter in Ohmmeter function between terminals “C” and “-“ the impedance value must be included between **100 and 200Kohm**.



If the measured value is out of the range given it means that the battery is damaged.

2. Measure the voltage with multimeter in Voltmeter function between terminals “+” and “-“, the value must be higher than **24 V** to allow the recharging.





8. Wiring Diagram

700 SERIES

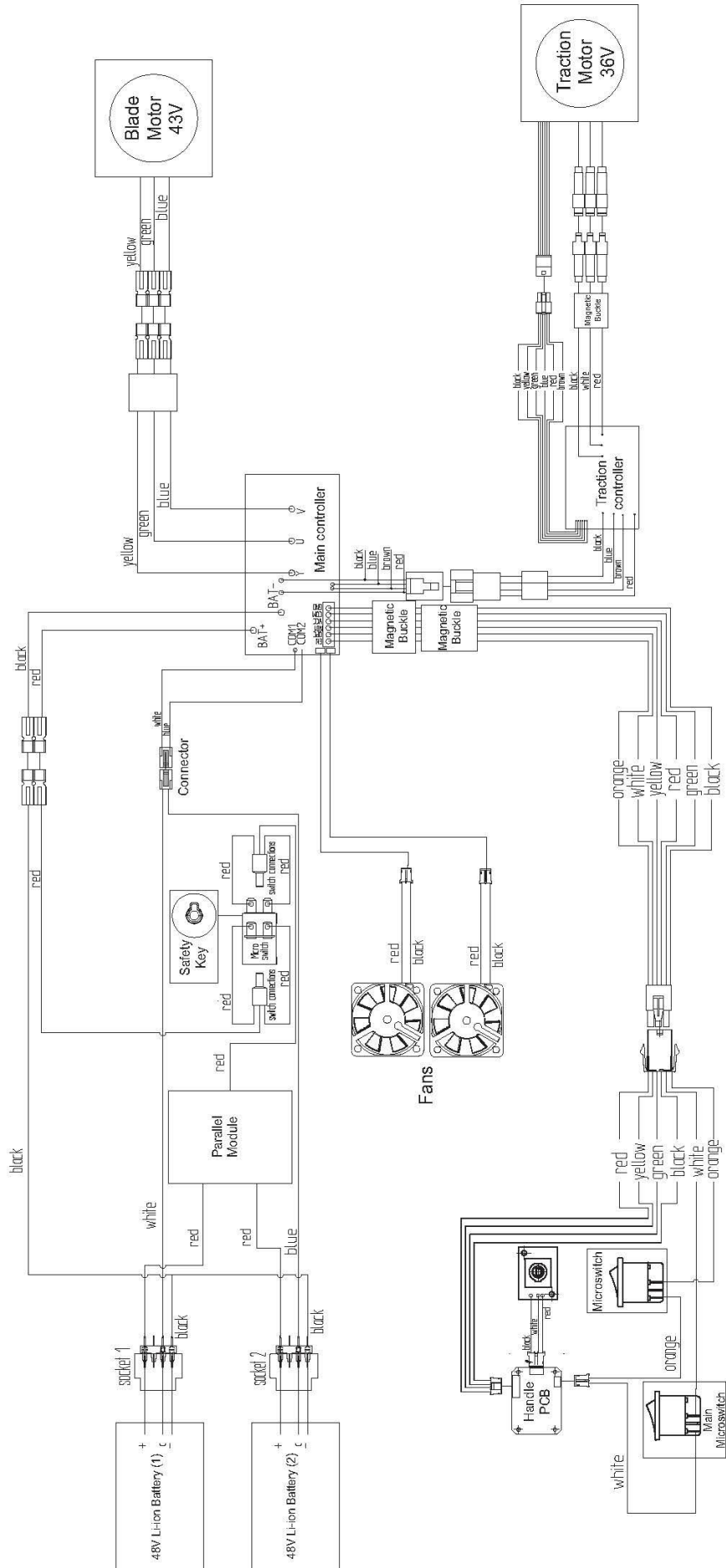



900 SERIES

