

# 72 72 *hydro*

# WORKSHOP MANUAL

Rel. 11.1

YEAR OF MANUFACTURE 2007→ 2014

The Manufacture reserves the right to make any improvements to the product of a technical or commercial nature that may be necessary. There may be, therefore, differences between the various series of machines and that described here, though the basic features and various repair methods will remain the same.

© by GLOBAL GARDEN PRODUCTS - No use of the illustrations or duplication, reproduction or translation, even partial, of the texts in this document may be made without explicit authorization.

## CONTENTS

### 1. Rules and procedures for Service Centres

*This chapter covers all the main aspects of the relationship between the manufacturer and the service centres.*

*A close collaboration between the manufacturer and the service centres is conclusive for solving problems in the most effective way as well as maintaining an image of efficiency and reliability. Compliance with these brief and simple guidelines will facilitate this task and prevent general misunderstandings and time-wasting for both the manufacturer and the service centre.*

### 2. General and safety regulations

*This chapter covers the main aspects of a servicing procedure and the general rules for guaranteeing a successful service which protects the environment and respects the safety of both the serviceman and the user of the apparatus.*

### 3. Maintenance

*This chapter deals with the criteria for routine maintenance.*

### 4. Adjustments and tuning

*This chapter deals with the adjustments to be made to remedy the more frequent performance failures and are usually resolved by quick checks and tunings.*

### 5. Removal of external parts and main assemblies

*For doing more difficult jobs, greater accessibility may be required. This can be done by taking the unit concerned off and working at the bench, or by removing the cover or other external parts. Whether or not this will be useful is at the discretion of the mechanic's experience.*

### 6. Repairs

*This chapter deals with all the more complex work connected with the replacement or repair of malfunctioning or worn parts.*

*The descriptions must follow a logical sequence and can include operations not specifically connected to a particular type of repair.*

*In this case, careful reading of the entire procedure can help you omit all those operations not connected with the case in hand without, however, overlooking anything that may be necessary.*

### 7. Electrical system

*This chapter deals with the problems and checks connected with the electrical system.*

*All work can be done using a tester without having to use special equipment.*

*The electrical diagrams can be useful to you for understanding how the system functions and to facilitate the pinpointing of any problems.*

### 8. Technical specifications

*This chapter summarises all the main information regarding the machine.*

## GENERAL INDEX

<b>1.1</b>	1	Identification and procedures
<b>2.1</b>	1	Safety regulations
<b>2.2</b>	2	Tools
<b>2.3</b>	2	Lifting
<b>2.4</b>	1	Placing the machine on its side
<b>2.5</b>	1	Opening the wheel cover
<b>2.6</b>	1	Practical hints
<b>3.1</b>	1	Criteria for maintenance
<b>4.1</b>	1	Blade engagement adjustment
<b>4.2</b>	2	Blade brake adjustment

- 4.3** 4 Brake adjustment
- 4.4** 1 Drive belt adjustment (▶ *mechanical drive models*)
- 4.5** 3 Drive lever adjustment (▶ *hydrostatic drive models*)
- 4.6** 0 Aligning the cutting deck
- 4.7** 0 Steering allowance adjustment
- 4.8** 0 Steering geometry adjustment
- 4.9** 0 Check on blade alignment
- 4.10** 2 Removing, sharpening and balancing the blade
- 4.11** 0 Adjustment of the collector channel guide
  
- 5.1** 1 Removal of the steering column protection cover
- 5.2** 0 Removal of the footboard
- 5.3** 3 Removal of wheels covers
- 5.4** 1 Removal of the rear plate
- 5.5** 0 Removal of the collector channel
- 5.6** 1 Removal of the engine
- 5.7** 6 Removal of the rear axle (Dana 4360-210)
- 5.7a** 4 Removal of the rear axle (Tuff Torq K46T)
- 5.7c** 0 Removal of the rear axle (Hydro Gear)
- 5.8** 2 Removal of the cutting deck
  
- 6.1** 2 Replacement of tyres and wheels
- 6.2** 0 Replacement of front wheel bearings
- 6.3** 0 Replacement of steering components
- 6.4** 0 Replacement of the drive belt
- 6.5** 2 Replacement of the blade belt
- 6.6** 0 Replacement of the support and shaft of the blade
- 6.7** 0 Replacement of the accelerator
- 6.8** 2 Replacement of the brake pads and disc (▶ *mechanical drive models*)
- 6.9** 1 Replacement of the drive lever unit (▶ *hydrostatic drive models*)
- 6.10** 0 Replacement of the lever return cable (▶ *hydrostatic drive models*)
- 6.11** 0 Replacement of the friction discs for clutch device (▶ *hydrostatic drive models*)
- 6.12** 1 Replacement of the seat's safety cable (▶ *in GGP and Honda GXV390 engine models*)
  
- 7.1** 2 Guide to the identification of problems in the electrical system
- 7.2** 1 Summary table for the cutting in of the safety devices
- 7.3** 3 Safety microswitches operation check and switches
- 7.4** 2 Terminal board supply check
- 7.5** 3 Starter relay and carburettor solenoid valve operation check
- 7.6** 2 Electronic card operation check
- 7.7** 2 Recharge circuit check
- 7.8** 1 Care and maintenance of the sealed battery
- 7.9** 1 Fitting safety microswitches
- 7.10** 4 Electrical diagrams
  
- 8.1** 2 Tightening torques and adjustments summary
- 8.2** 3 Summary of main assembly amounts and checks

## INTRODUCTION

This manual has been compiled to help Service Centres with the maintenance, dismantling and repair of the following versions of "Rider" 72 riding mower:

- mechanical drive with gear box;
- hydrostatic drive (hydro).

Each page of this manual states the following information:

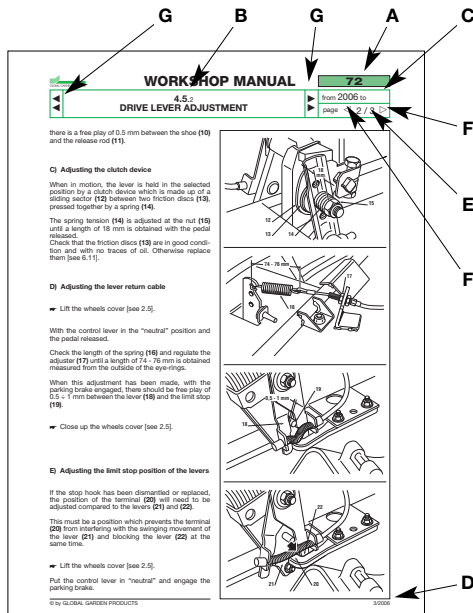

- A)** Machine or machine series to which the page applies.
- B)** Page number, specifically:
  - the first two figures separated by a point indicate the section and the chapter
  - the third figure indicates the modification index.
- C)** Temporary validity of the page, with reference to the year of manufacture or serial numbers.
- D)** Date of release.
- E)** Page number and total number of pages dedicated to the subject.
- F)** Any previous or ensuing pages dedicated to the subject.
- G)** Any chapters before or after the current one.

The manual refers to the following symbols:

**Warns of operations that should be carried out with utmost care to avoid impairing the functionality and safety of the lawnmower.**

**Warns of operations that should be carried out with utmost care to avoid injury to the operator.**

**Reference to another procedure or part of the manual.**

**This symbol highlights all those operations that require different working methods depending on the type of machine, subsequent modifications or accessories fitted.**

**NOTE**  
Whenever a reference is made to a position on the machine "front", "back", "left" or "right" hand side, this is determined by facing the direction of forward travel.

The manual has left out the simplest and quickest operations that can be handled by a good mechanic, while concentrating more on specific aspects and the best servicing procedures.

You are asked to read through this manual to acquire a basic understanding of the machine, which is necessary for working rationally without making errors or wasting time.

All problems related to use are fully covered in the user manual.

## 1.1 IDENTIFICATION AND PROCEDURES

### A) Identification

#### 1) Machine

Each machine has a label attached **(1)** under the driver's seat which shows the technical specifications, the model and the serial number.

**The model and serial number must be shown on each repair sheet when requests are made under guarantee, and are indispensable for spare part orders.**

#### 2) Transmission (Rear axle)

The transmission unit (both mechanical and hydrostatic) is made up of an engine block including the rear axle. This unit is made by another manufacturer to our precise technical specifications which differentiate it from similar items by this same Manufacturer.

**The serial number on the label (2) clearly identifies the product and its specifications. This number must always be quoted when requesting spare parts or any information from the Manufacturer.**

#### 3) Engine

The engine is made to precise technical specifications which differentiate it from similar items by this same Manufacturer.

**The serial number on the label clearly identifies the product and its specifications. This number must always be quoted when requesting spare parts or any information from the Manufacturer.**

### B) Guarantee validity

The guarantee is supplied under the terms and the limits of the contractual relations in being. As far as the engine and the transmission unit are concerned, the conditions given by their respective manufacturers apply.

### C) Service repairs after guarantee period

The Service Centre has to make out a report containing the machine's serial number, a summary of

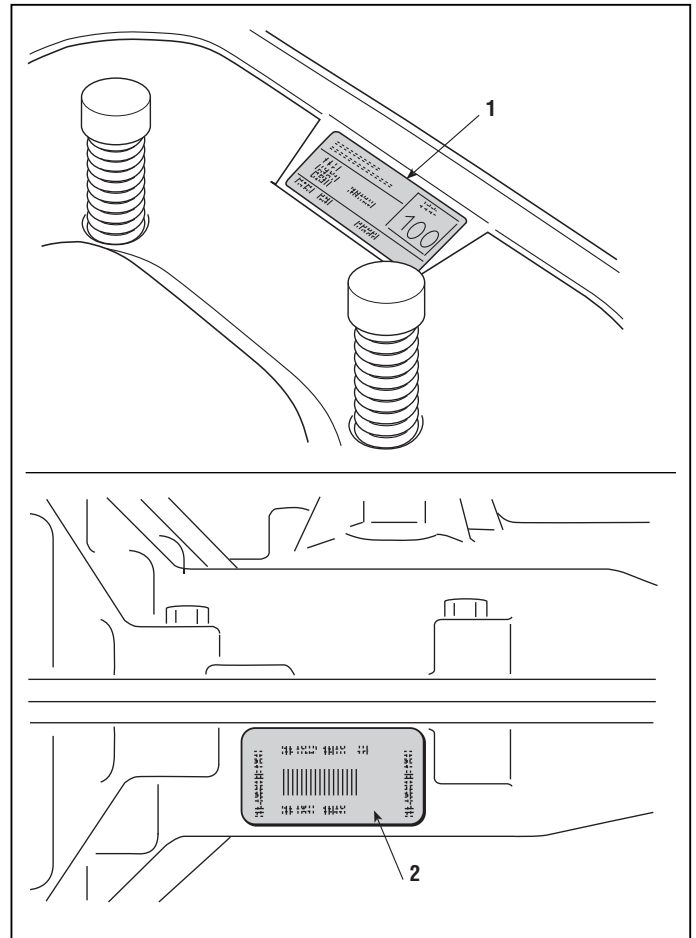

the problem, the repairs carried out and any spare parts used for each repair done on the machine.

A copy of this report must be retained to be made available to the Manufacturer together with the parts in case of any subsequent disputes with Customers.

### D) Fault notification

The Manufacturer welcomes any notifications of faults that recur with particular frequency. It gives the opportunity for a careful inspection of the problem and the implementation of corrective action at production level.

Similarly, the Manufacturer will notify of any faults discovered on the machines produced, with recommendations for the most suitable procedures for their remedy.

### E) Spare parts request

When requesting spare parts, the code number must be given, referring to the exploded charts for the year of manufacture, shown on the identification label [point A].

## 2.1.1 SAFETY REGULATIONS

from 1998 to

page 1 / 1

### 2.1 SAFETY REGULATIONS

#### A) Qualification of operators

All maintenance, disassembly and repairs must be carried out by expert mechanics who are familiar with all the accident prevention and safety regulations after reading through the procedures in this manual.

#### B) Safety measures

All the machines are manufactured in accordance with the strict European safety regulations in force. To maintain these levels of safety in the longer term, the Service Centres should work to this end by making appropriate checks every time there is the chance to do so.

Particularly, every time there is work done on the machine the Service Centre should:

##### 1) check:

- that safety microswitches are working correctly [see 7.3];
- that the casings and protection covers have not been removed;
- that the labels with instructions or provisions have not been removed or have become illegible (these form an integral part of the safety system).

##### 2) they should also:

- restore to proper working order any safety devices which have been manipulated or removed;
- reattach inefficient, damaged or missing casings and protection covers;
- replace illegible labels;
- not endorse any repair or modification on the machine or the engine which results in a change in performance or use that is incorrect or different from the purpose for which it was designed and approved;
- warn the Customer that the failure to comply with the above points results in the automatic annulment of the Guarantee and the Manufacturer declines all responsibility, as also shown in chapter 1 of the Instruction Booklet.

#### C) Precautions during servicing

The operations described in this manual do not entail particularly hazardous situations besides the normal hazard related to mechanical operations

and that can be avoided by taking the necessary care and attention normally required for this type of work.

As well as following the usual accident prevention regulations that apply to most repair shops, we recommend you:

- taking out the ignition key before beginning any repair work.
- protect hands with suitable working gloves, especially when working near the cutting unit;
- check that you do not cause accidental petrol leaks or other losses;
- do not smoke when working on the tank or when handling petrol;
- do not inhale oil or petrol fumes;
- clean up all traces of spilt petrol immediately;
- test the engine in a well-ventilated environment or where there are adequate exhaust fume extraction systems;
- do not pollute the environment with oil, petrol or other waste and dispose of all waste in accordance with the laws in force;
- ensure that other persons cannot accidentally carry out actions that may physically endanger those working on the machine.

#### D) Necessary equipment

All the operations can be carried out with the tools normally used in a good garage.

Some operations require special equipment and tools [see 2.2].

#### E) Symbols and terms used for safety purposes

Some paragraphs in this manual are preceded by symbols which indicate the following:



Operations that should be carried out with utmost care to avoid impairing the functionality and safety of the lawnmower.



Operations that should be carried out with utmost care to avoid injury to operators.

**“WARNING”** stresses the risk of injury to oneself and others if instructions and regulations are not observed



## 2.2.2 TOOLS

from 1998 to  
page 1 / 1

### 2.2 TOOLS

All work can be carried out using the tools normally available from a good workshop. However, it is advisable to have a set of special tools (1 ÷ 5).

These tools (1 ÷ 5) are to be used whenever is given in this text.

1. Blocks H = 26 mm for adjusting the cutting deck
2. Blocks H = 32 mm for adjusting the cutting deck
3. Bush for assembly of blade bearings
4. Stopper for assembly of wheel bearings
5. Pulley extractor

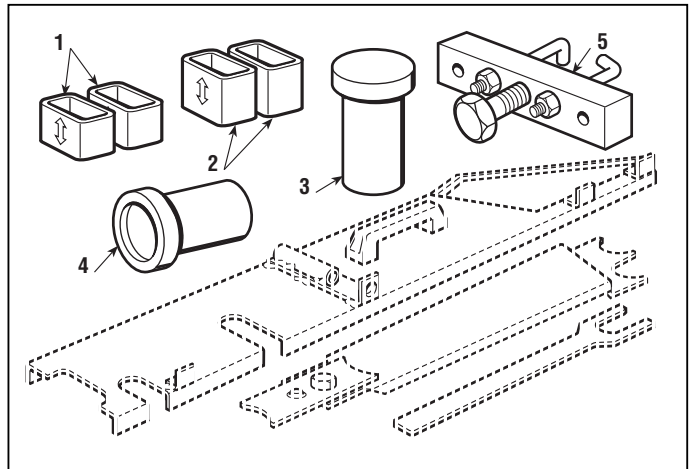



## 2.3.1 LIFTING

from 1998 to  
page 1 / 1

### 2.3 LIFTING



The machine must never be lifted using a hoist or other lifting equipment which uses cables.



#### A) Front

ONCE THE PARKING BRAKE HAS BEEN ENGAGED, the machine can be lifted using a jack which pushes on the underside of the frame. Place a wooden block **(1)** between the base of the jack and the frame and check that the free movement of the front spring equaliser has not been obstructed.

#### B) Rear

Place two suitable blocks **(2)** beneath the lower edge of the plate. In any case, an appropriately sized wedge **(3)** should be placed behind the opposite wheels to stop the machine from accidentally moving.

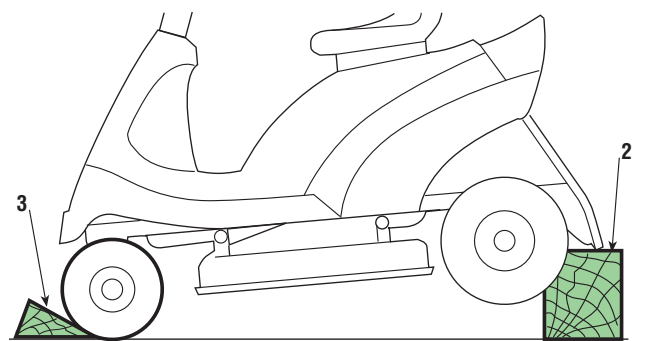
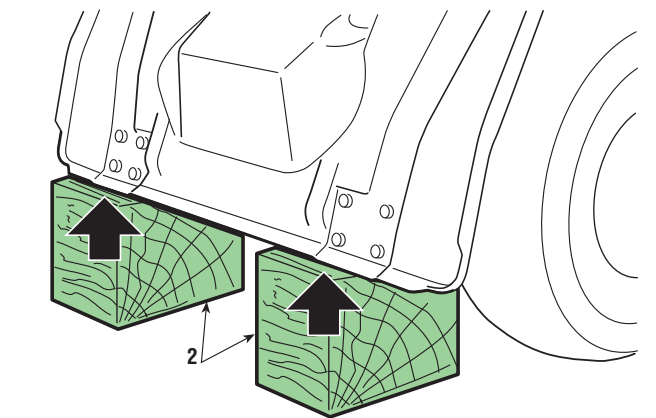
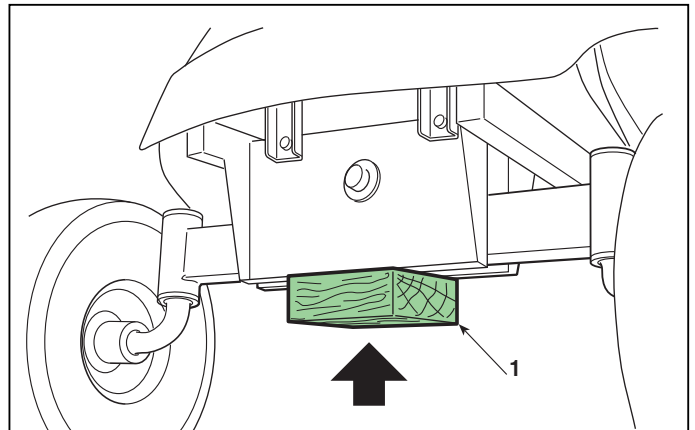



## 2.4.1 PLACING THE MACHINE ON ITS SIDE

from 1998 to  
page 1 / 1

### 2.4 PLACING THE MACHINE ON ITS SIDE



**WARNING!** Two people will be needed for this work.

When moving the machine onto its side it should only be gripped at strong parts (steering wheel, seat, frame, etc.) and **NEVER** by the plastic parts of the body.

The fuel tank must be totally emptied before placing the machine on its side.

Put the machine onto a flat and firm surface, remove the grass-catcher, engage the parking brake and raise the cutting deck to its maximum height.

The machine must only be laid on its right hand side, resting the seat **(1)** and one of the corners of the grass-catcher **(2)** as shown. When doing this, firmly grip the steering wheel and the seat and tip the machine over until it is resting on the grass-catcher, taking care not to damage the body's plastic parts.



**WARNING!** Before carrying out any type of work make sure that the machine is completely stable, and avoid operations that could cause it to fall over.



**WARNING!** Be just as careful when putting the machine back on a flat surface; two people are needed for this operation.

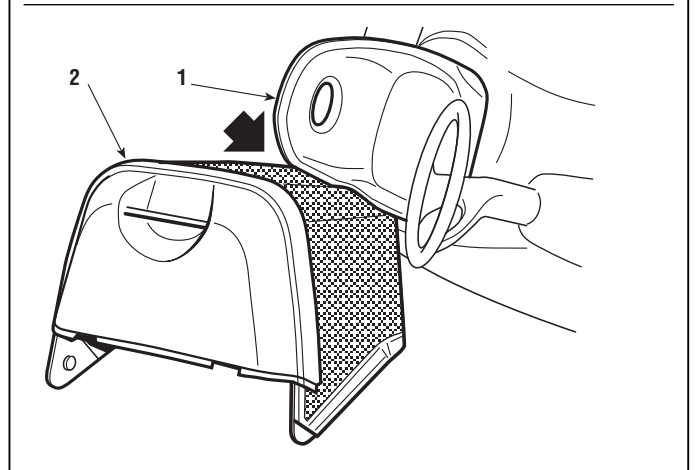
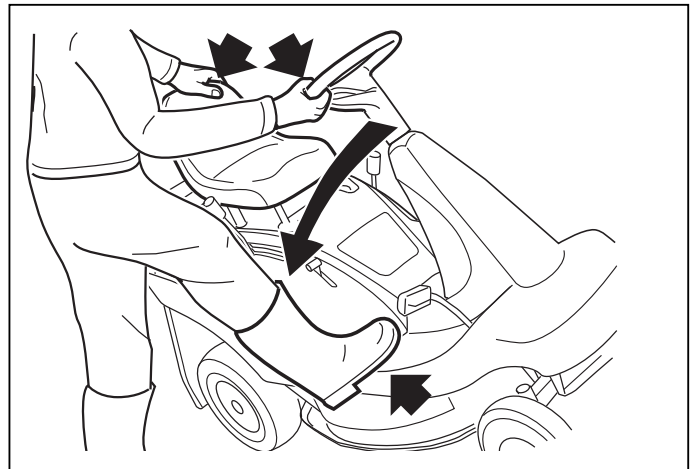

## 2.5.1 OPENING THE WHEEL COVER

from 1998 to

page 1 / 2

### 2.5 OPENING THE WHEEL COVER

The engine and the mechanical units can be reached by turning back the wheel cover (1).

There are specific indications for opening the cover which are shown below and also in the instruction handbook.

Remove the grass-catcher or stoneguard and move the machine to a flat floor. Raise the cutting deck to its maximum height and place blocks (2) of about 65 – 70 mm beneath its edge in order to support the deck during subsequent operations.

► **mechanical drive models:** engage the parking brake;

► **hydrostatic drive models:** put the drive release lever in the «ENGAGED» position. This is because the parking brake needs to be disengaged to ensure the necessary movement to the speed lever.

Unscrew the knob on the lever (3) and ...

► **in mechanical drive models:** put it into neutral «N»

► **in hydrostatic drive models:** put it into position «R»

Open the access hatch (4) and unscrew the nut (5) with a 13 mm spanner.

Release the lever (6) so that the deck rests on the blocks, and keep it held to the side so that it does not slip into any of the notches. Grip the base of the seat (7) and turn back the cover.

When closing, make sure that the channel (8) is properly fitted onto the support (9) and resting on the right-hand guide. Put the lever (3) into position «R» and lower the cover (1) at the level of the levers (3) and (6).

First put the lever (6) into its housing, and then lever (3), lower the cover until it centres on the fixing screw.

If this has been done correctly and the guide (9) is properly positioned, the opening of the channel will easily slip into the hole in the plate (10) without any need to guide it in manually.

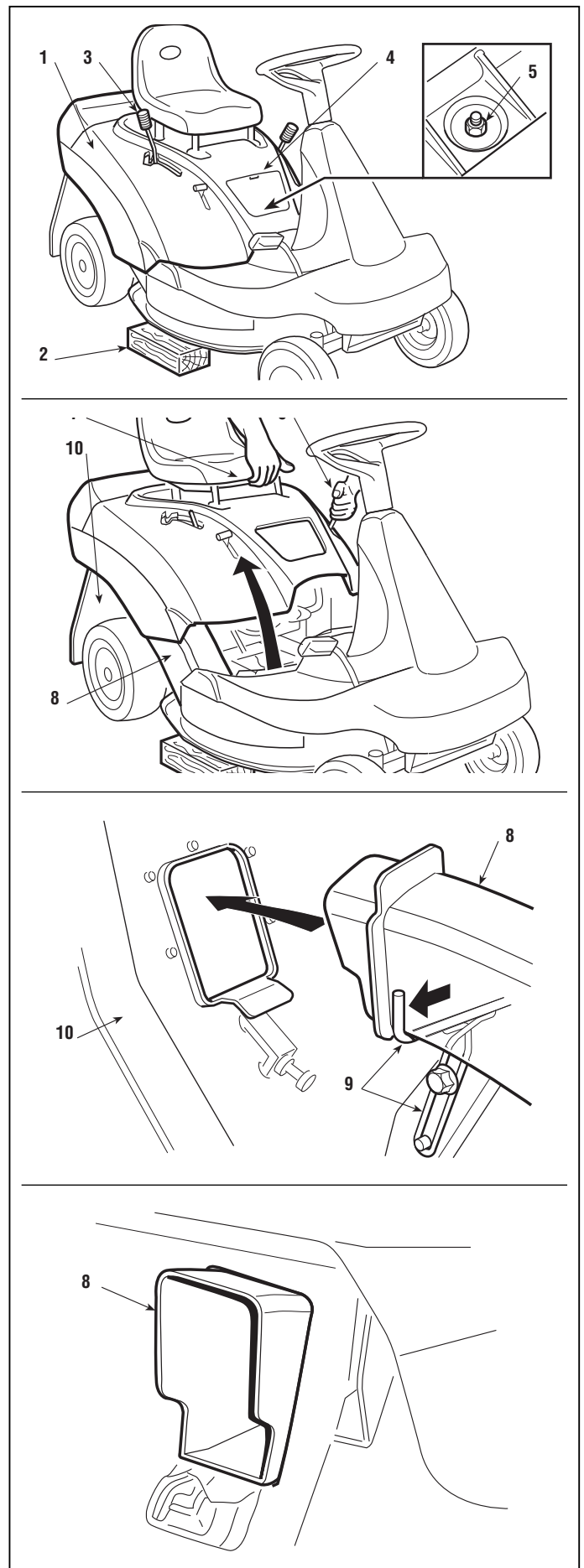

 	<p>2.5.1  <b>OPENING THE WHEEL COVER</b></p>	 	<p>from 1998 to          page ◀ 2 / 2</p>
--	--	--	---

If it does not enter easily and correctly,

☛ Adjust the insertion [see 4.11].

Fully tighten the nut **(5)**, put the lever **(6)** in position «7» engaging it in the stop notch, and remove the blocks **(2)**. Then refit the lever knob **(3)** and the hatch **(4)**.



## 2.6.1 PRACTICAL HINTS



from 1998 to  
page 1 / 1

### 2.6 PRACTICAL HINTS

#### A) Fitting snap rings

One side of the “Benzing” snap rings **(1)** has a rounded edge and the other a sharp edge.

For maximum grip the rounded part needs to be facing towards the element to be held **(2)**, with the sharp edges on the outside.

#### B) Joint pivot pins

There are a large number of pivot pins, usually connected to rods, that need to be able to move in various directions.

A typical situation has the pin **(3)** fixed by a self-locking nut **(4)** with two anti-friction washers **(5)** in between the pin **(3)** and the support element, and between this and the nut **(4)**.

Since these are joints, the nut must never be tightened completely but only so much that it can ensure the free rotational movement of the pin on its axis without, however, creating excessive free play which could result in the parts concerned becoming misaligned and failing to work correctly.

#### C) Crown fasteners

Some pin ends **(6)** are secured by crown fasteners **(7)**. During dismantling, these fasteners are always damaged and lose their hold, **so they should never be reused**.

On assembly, make sure it is inserted in the right direction and push the fastener **(7)** onto the pin using a pipe or socket spanner **(8)** with the right diameter, so that it can be fitted without deforming the fastener “crown”.

**A deformed fastener should always be replaced.**

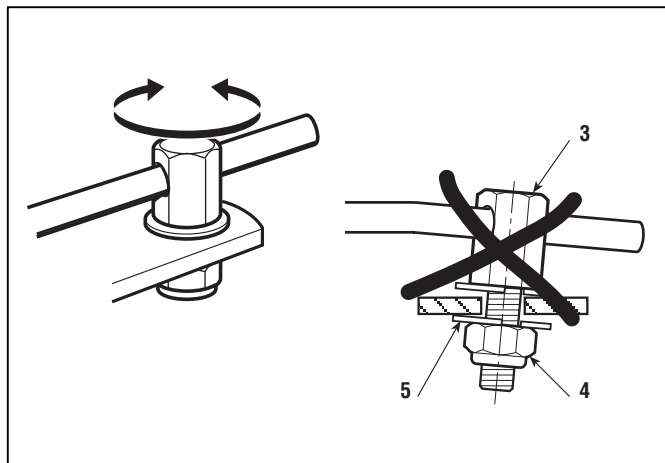
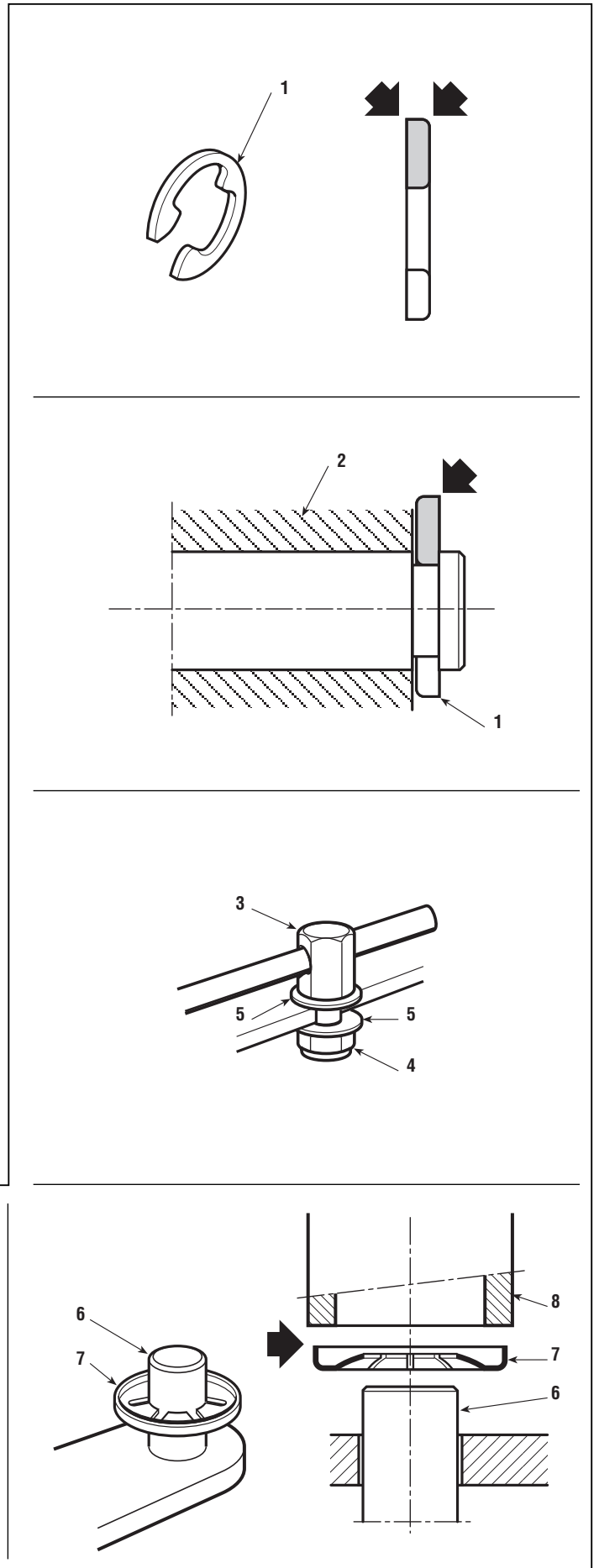

## 3.1.1 CRITERIA FOR MAINTENANCE

from 1998 to

page 1 / 1

### 3.1 CRITERIA FOR MAINTENANCE

The Instruction Handbook has a number of operations to be carried out by the Customer for a minimum of basic maintenance, and other operations not always within his capacity.

For this reason the Service Centre should undertake to keep the machine in perfect working order in two ways:

- a) Tuning the machine whenever possible.
- b) Proposing a regular maintenance programme to the Customer to be carried out at prearranged intervals (for example, at the end of the summer or prior to a long period of inactivity).

#### a) Occasional tuning

- Check working order of safety devices and renew illegible or missing labels
- Check tyre pressures
- Clean air filter
- Check engine oil level
- Check for fuel leaks
- Align cutting deck
- Sharpen and balance the blade and check the condition of the hub
- Check for wear in the belts
- Check the blade brake and engagement
- Grease joint pins and bushes of front wheels
- Grease the bush of the drive lever (► *hydrostatic drive models*)
- Check and tightening of engine screws
- Check all those items indicated in the engine booklet

#### b) Regular maintenance

- **All work carried out in section a), plus:**
- Check battery charge
- Check tension of belts
- Adjust drive engagement (► *mechanical drive models*)
- Adjust brake
- Adjust blade engagement
- Adjust blade brake
- Check steering allowance
- Check front bearings
- General lubrication
- Clean away grass cuttings and wash exterior
- Clean and wash inside cutting deck and collector channel
- Clean and wash grass-catcher
- Touching up of any damaged paint

## 4.1.1 BLADE ENGAGEMENT ADJUSTMENT

from 2003 to

page 1 / 1

### 4.1 BLADE ENGAGEMENT ADJUSTMENT

The blade is run from the engine using a «V» belt and is engaged by a stretcher worked from the lever.

After a certain amount of use the belt can become longer which can result in malfunctioning, i.e.:

- belt slipping = belt stretched
- difficulty in disengaging, with a stiff lever and the blade continuing to run = belt shortened

In both cases the stretcher needs to be adjusted.

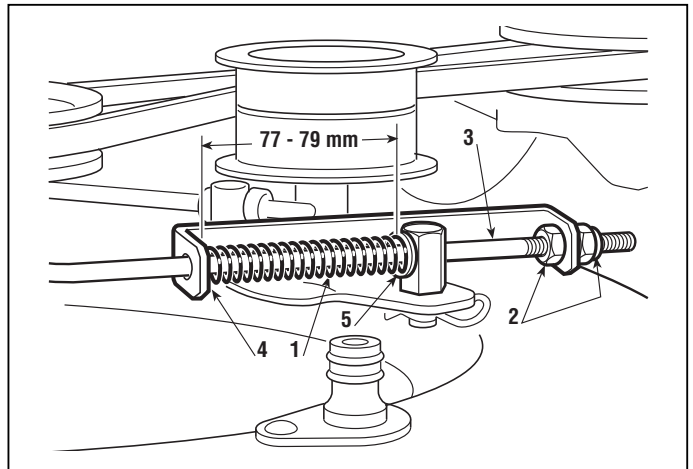

The length of the spring **(1)** must be adjusted with the blade engaged and the cutting deck in position «1», because in other positions the length can vary considerably.

Loosen the nuts **(2)** and screw or unscrew them on the control rod **(3)** in order to obtain a distance of 77-79 mm between the bracket **(4)** and the inside of the washer **(5)**.

When the adjustment has been made, screw the nuts **(2)** back on.

When the blade engagement has been adjusted it is always advisable to ...

- ➡ Check that the blade brake is working correctly [see 4.2].

## 4.2.2 BLADE BRAKE ADJUSTMENT

from 2004 to

page 1 / 1

### 4.2 BLADE BRAKE ADJUSTMENT

The blade has a brake which stops rotation within five seconds:

- when the blade disengages
- when the operator gets out of the seat without disengaging the blade.

Longer braking times do not comply with safety regulations, but adjusting the brake so that it stops quicker than this can cause the belt to slip on the shoe resulting in overheating with the typical smell of burnt rubber.

#### A) Adjustment of the brake after disengaging the blade

The braking power on the blade belt is generated by the spring (1) which catches the blade engagement lever (2) after disengagement. In order to use all the braking power, do not allow the lever to reach its end of travel in relation to the guide shoe (3).

Check that the brake shoe (4) is not deformed.

- ➡ Remove the steering column cover [see 5.1].

Disengage the blade and check that the lever (2) and guide shoe (3) have a clearance of at least 7-8 mm.

If this is not so, adjust the nuts (5) on the tie-rod (6) until you achieve this clearance.

- ➡ Reassembly the steering column cover [see 5.1].

#### B) Adjustment of the brake after the operator gets out of the seat (▶ models with GGP and Honda GXV390 engine only)

- ➡ Lift the wheels cover [see 2.5].
- ➡ Remove the collector channel [see 5.5].

The braking force on the blade belt is generated by the return spring on the seat, which acts on the brake shoe (4) via the cable (8) and the spring (9).

After making the adjustment indicated in point "A", regulate the adjuster (10) until the spring (9) is 48-49 mm long with the blade disengaged.

- ➡ Reattach the collector channel [see 5.5].
- ➡ Close up the wheels cover [see 2.5].



After adjustment, disengaging the blade or getting out of the seat, the brake shoe (4) should press adequately against the belt (7) and stop rotation within 5 seconds of disengagement.

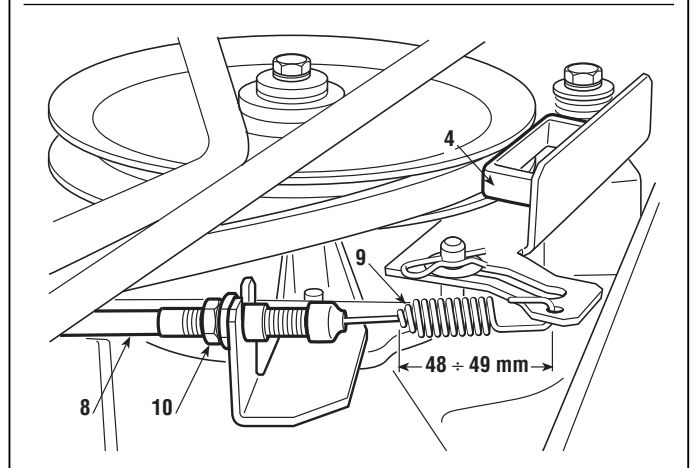
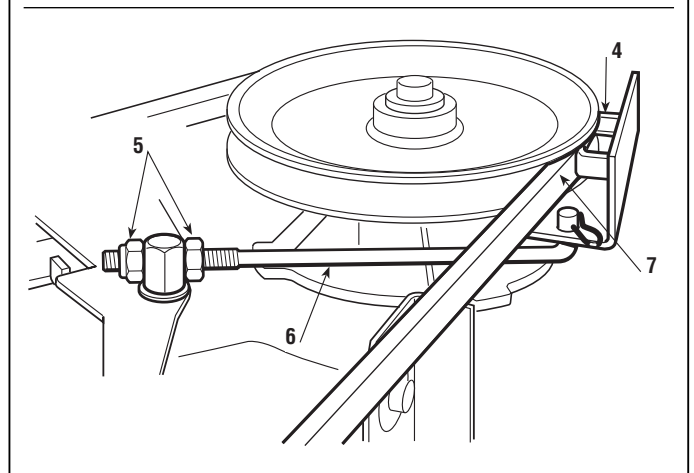
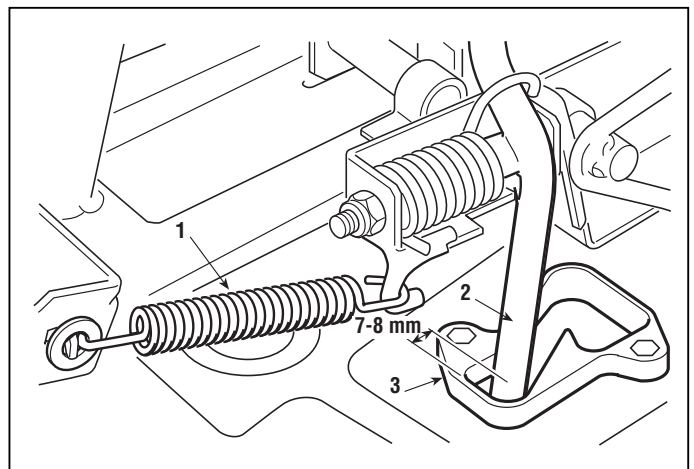

## 4.3.4 BRAKE ADJUSTMENT

from 2007 to

page 1 / 2

### 4.3 BRAKE ADJUSTMENT

*Reduced braking power is corrected by adjusting the spring on the brake rod which can be reached after having lifted the wheels cover.*

➡ Lift the wheels cover [see 2.5].

The adjustment is to be made with the parking brake engaged and consists of altering the length of the spring to the best measurement. The braking capacity is increased by screwing the nut down on the rod (and thus shortening the length of the spring).

► **in mechanical drive models:  
(Dana 4360-210):**

Loosen the nut (1) which retains the bracket (2) and then turn the nut (3) until the spring (4) is 46 - 48 mm long, measured from the inside of the washers.

When the adjustment has been made, tighten the nut (1).

Never go under these amounts to avoid overloading the brake unit.



If braking is still poor or uneven even after having made the adjustment, uncouple the pin (7) of the control rod (8) from the lever (5) uncouple the control rod (8) pin (7) or from the lever (5) while the pedal is fully released, and then check that this lever has a free movement of 12 mm before beginning the braking action.

If this is not the case, it is possible to adjust the free movement at the nut (6), unless the brake pads or disc are so worn that they need replacing [see 6.8].

Refit the pin (7) with the control rod (8) and fully tighten the nut (9); then recheck the length of the spring (4).

► **in hydrostatic drive models:  
(Tuff Torq K46T)**

Turn the nut (10) so that the spring (11) is 45 - 47 mm long, measured from the inside of the washers.

Never go under these amounts to avoid overloading the brake unit.

**NOTE**

No further adjustments to the braking system are required.

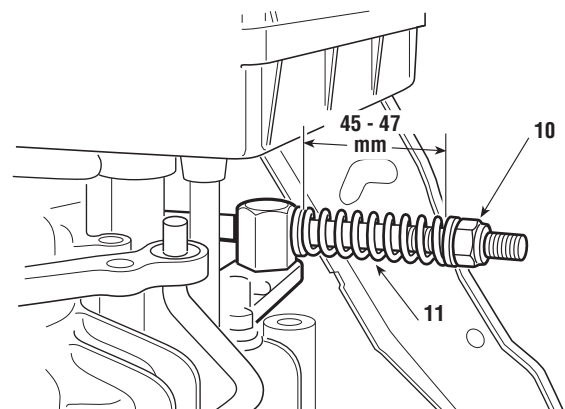
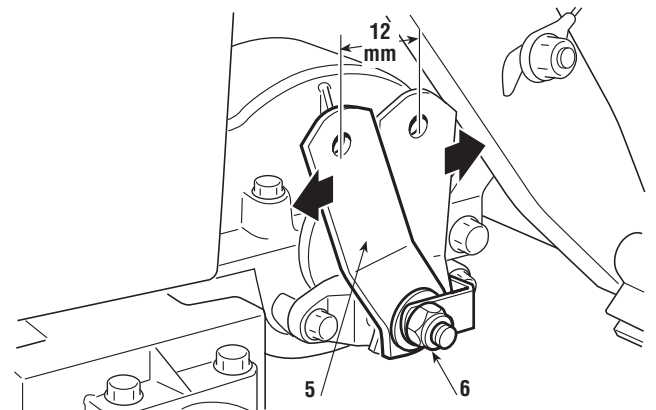
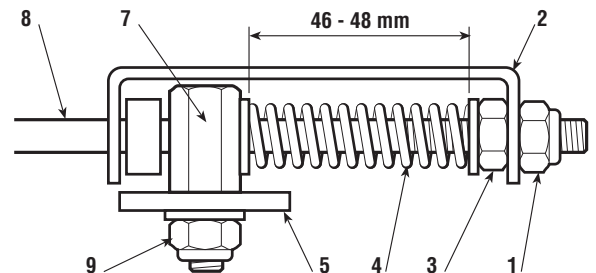



4.3.4  
BRAKE ADJUSTMENT

from 2007 to

page 2 / 2

**► in hydrostatic drive models:  
(Hydro Gear)**

Loosen the nut (21) and then turn the nut (22) so that the length of the spring (23) is 34-36 mm measured from the inside of the washers. Never go under these amounts to avoid overloading the brake unit.

**NOTE**

No other adjustments to the brake system are required

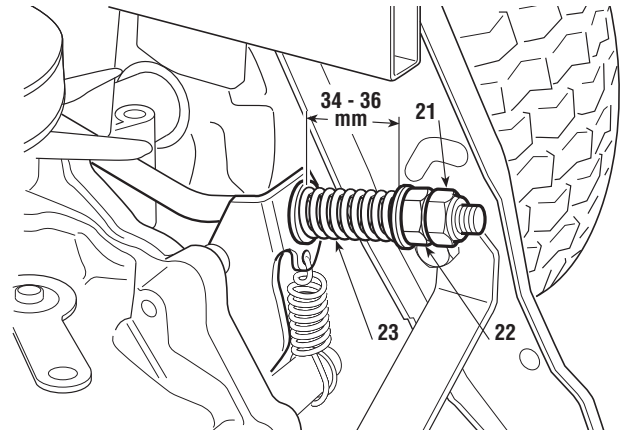

When the adjustments have been made, the parking brake should prevent the machine from moving on a slope of 30% (16°) with the driver in position.

➡ Close up the wheels cover [see 2.5].

## 4.4.1 DRIVE BELT ADJUSTMENT

from 1998 to

page 1 / 1

### 4.4 DRIVE BELT ADJUSTMENT ( ➤ *mechanical drive models*)

*If it seems that the forward drive is not working properly after a long period of use or after replacing the belt, this may be caused by a change in the length of the belt.*

- A loose belt reduces output from the transmission and limits forward movement power;
- a belt which is too tight increases noise and results in jerky movements or tipping up when engaging the drive.

*In these cases the stretcher will need to be adjusted.*

The stretcher can be reached through the hatch at the base of the seat.

Adjust the tension of the spring **(1)** by turning the nuts **(2)** until you obtain a length of 86 mm measured from the outer ends of the spring, with the drive controls released.

In this condition, the control lever **(3)** should be completely vertical.

When the adjustment is done, tighten the nuts **(2)**.

#### NOTE

➤ **hydrostatic drive models:** there is no adjustment to be made to the drive belt.

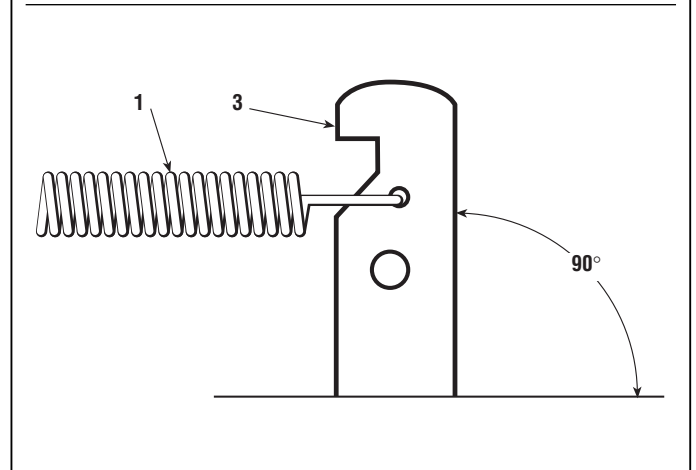
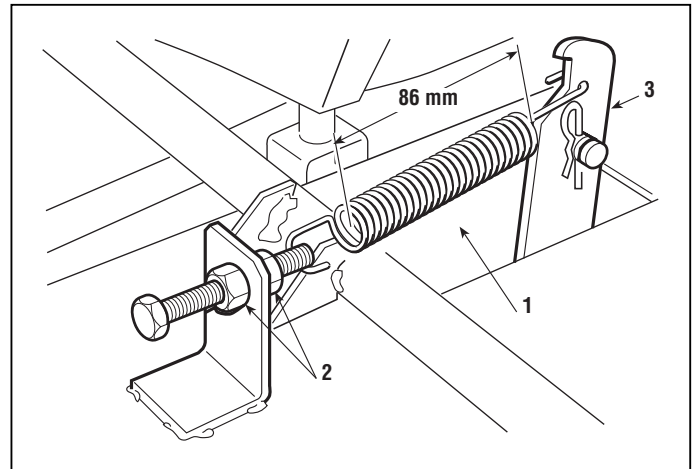

## 4.5.3 DRIVE LEVER ADJUSTMENT

from 2006 to

page 1 / 3

### 4.5 DRIVE LEVER ADJUSTMENT ( ► hydrostatic drive models)

*This adjustment should be made every time work is done on the drive lever unit or when the pedal shaft, back axle or the lever return cable are dismantled.*

*The main indicators that it is not working properly are:*

- *the lever does not return when the pedal is pressed = cable loose,*
- *the lever does not go the full distance, reducing performance = cable too tight,*
- *the lever is stiff = the spring for the clutch device is badly adjusted,*
- *the lever is too loose and, under pressure, does not stay in position = the spring for the clutch device is badly adjusted or there is oil on the friction disc,*
- *the machine has a tendency to move when the lever is in "neutral" = the connection rod is incorrectly adjusted.*

#### A) Adjusting the "neutral" position

- Remove the right-hand rear wheel [ see 6.1].
- Remove the collector channel [see 5.5]

The pedal position is to be adjusted starting with the lever **(1)** or **(1a)** of the hydrostatic unit in the "neutral" position.

#### ► for Tuff Torq K46T drive models:

Keep the lever **(1)** in the "neutral" position; this position "N" can be easily recognised as it is forced to stay there by a fastening sphere.

#### ► for Hydro Gear drive models:

Keep the lever **(1a)** in the "neutral" position; this 'N' position is achieved by fitting a 28 mm high block under the protruding end of the screw **(1b)**.

**NOTE** - The "neutral" position on a new drive unit, or one overhauled by the Manufacturer, is given by a spacer which must be removed after the unit has been adjusted.

Ensure the wheel cover is closed and fitted securely in place, now adjust the nuts **(2)** on the bar **(3)** until the control lever **(4)** is centred on the central groove **(5)** on the cover.

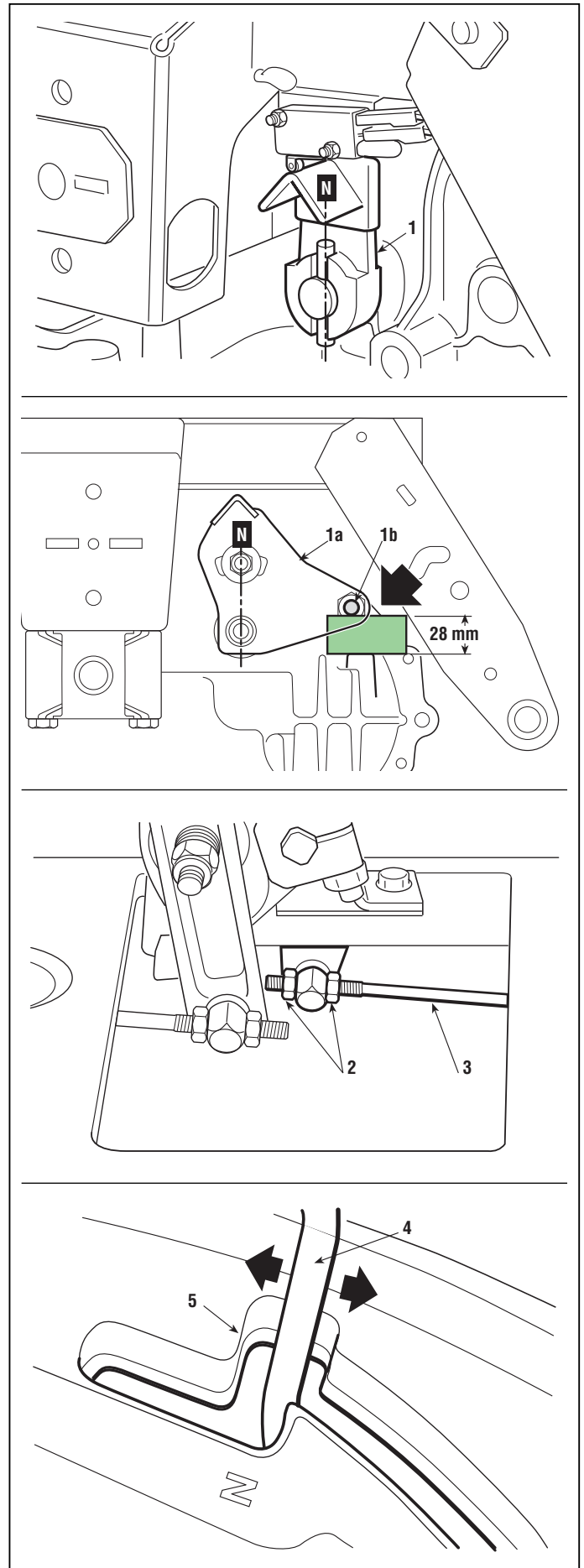

## 4.5.3 DRIVE LEVER ADJUSTMENT

from 2006 to

page 2 / 3

Check that the drive to the wheels engages only when the control lever (4) is moved forwards or backwards.

Check that the probe of the microswitch (6) is in the "pressed" position on the tip of the cam (8). If it isn't, loosen the locknuts (7) and move the microswitch (6) sufficiently so that by moving the control lever (4) the click of the contact can be heard passing from the "pressed" position to the "released" position.

➔ Reattach the collector channel [see 5.5].

### B) Adjusting the release rod of the clutch device

With the brake pedal released, turn the nuts (9) until there is a free play of 0.5 mm between the shoe (10) and the release rod (11).

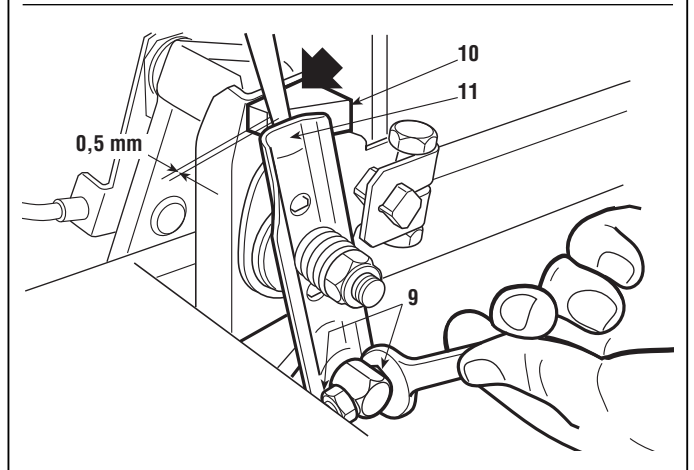
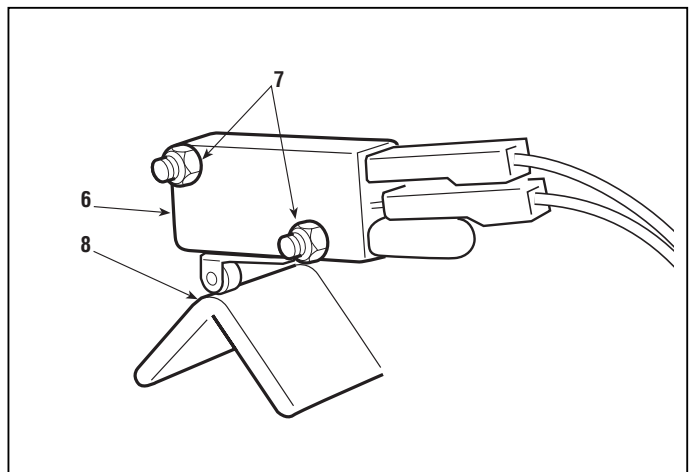

### C) Adjusting the clutch device

When in motion, the lever is held in the selected position by a clutch device which is made up of a sliding sector (12) between two friction discs (13), pressed together by a spring (14).

The spring tension (14) is adjusted at the nut (15) until a length of 18 mm is obtained with the pedal released.

Check that the friction discs (13) are in good condition and with no traces of oil. Otherwise replace them [see 6.11].

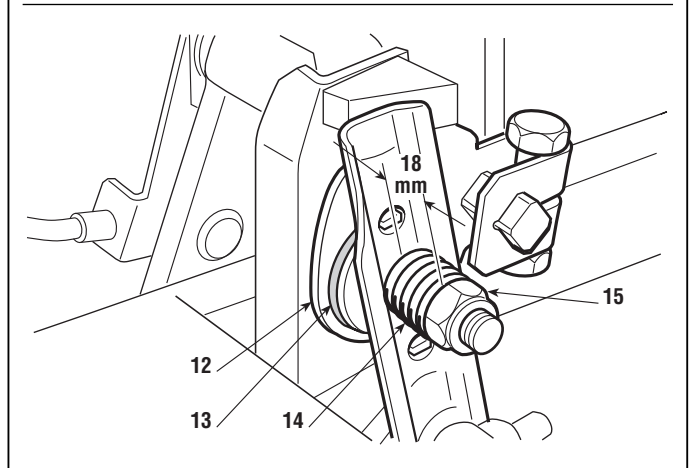

### D) Adjusting the lever return cable

➔ Lift the wheels cover [see 2.5].

With the control lever in the "neutral" position and the pedal released.

Check the length of the spring (16) and regulate the adjuster (17) until a length of 74 - 76 mm is obtained measured from the outside of the eye-rings.

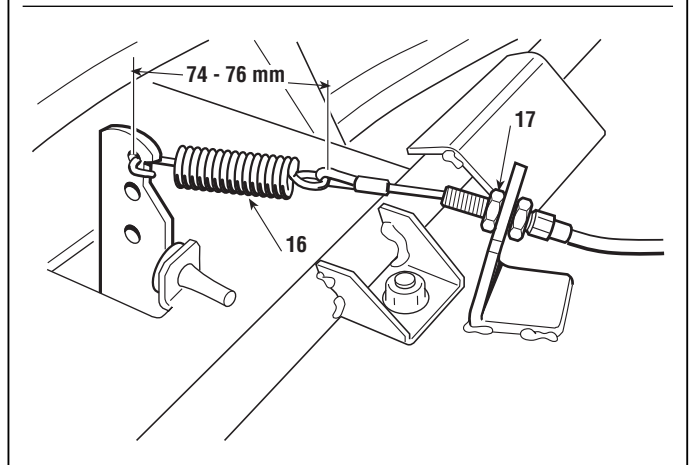

## 4.5.3 DRIVE LEVER ADJUSTMENT

from 2006 to  
page 3 / 3

When this adjustment has been made, with the parking brake engaged, there should be free play of 0.5 ÷ 1 mm between the lever (18) and the limit stop (19).

➡ Close up the wheels cover [see 2.5].

### E) Adjusting the limit stop position of the levers

If the stop hook has been dismantled or replaced, the position of the terminal (20) will need to be adjusted compared to the levers (21) and (22).

This must be a position which prevents the terminal (20) from interfering with the swinging movement of the lever (21) and blocking the lever (22) at the same time.

➡ Lift the wheels cover [see 2.5].

Put the control lever in “neutral” and engage the parking brake.

With both nuts (24) loosened, close the two levers (22) and (23) so that the terminal (20) is held between them, push it back as far as possible and then tighten the two screws (24).

➡ Close up the wheels cover [see 2.5].

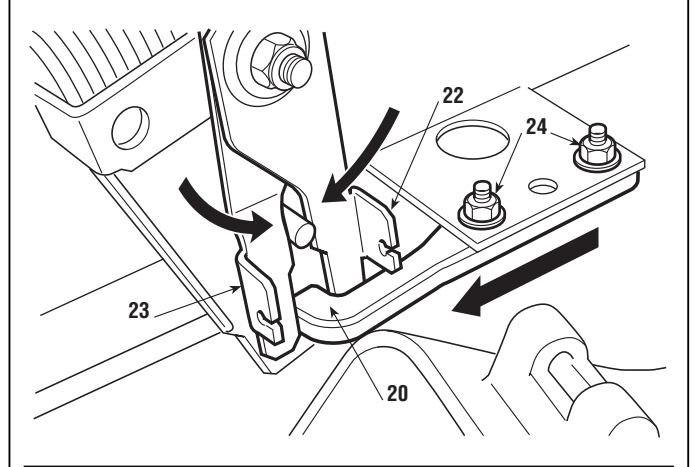
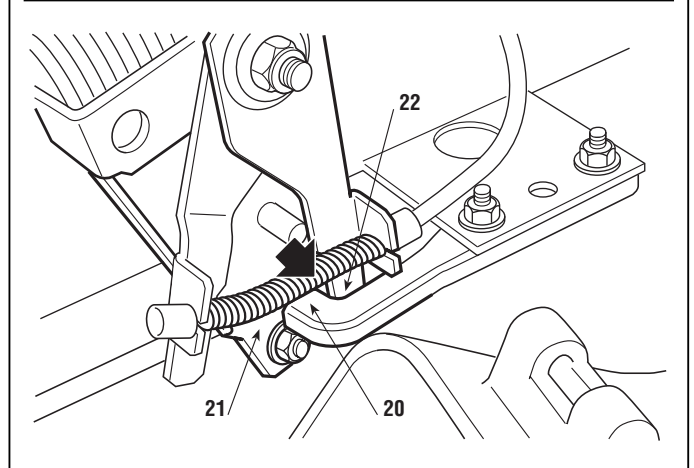
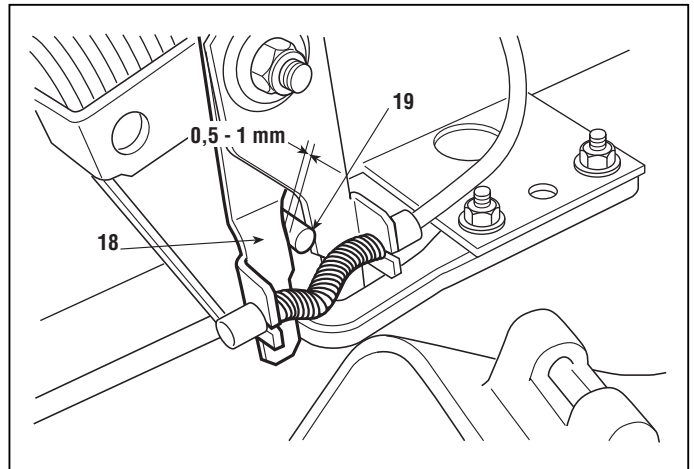

### Tightening torque

**24** Nuts for lever limit stop ..... 8 ÷ 11 Nm

## 4.6.0 ALIGNING THE CUTTING DECK

from 1998 to

page 1 / 2

### 4.6 ALIGNING THE CUTTING DECK

The cutting deck is lowered by a lever and is guided by a connecting rod at the front and one at the back right. A third connecting rod at the front left is connected to the deck by an adjuster system.

In order to get a good cut it is essential that the cutting deck is parallel with the ground crosswise, and slightly lower at the front.

Two adjustments can be made on the jointed system of the cutting deck:

- a) a combined adjustment to the parallel and the minimum height front and back
- b) an adjustment to the parallel across the cutting deck alone

Check the tyre pressures. If one or more tyres have been replaced and there are found to be differences in diameter, **do not attempt to compensate these differences by giving different tyre pressures**, but make the adjustments as in points "A" and "B".

#### A) The combined adjustment to the parallel and the minimum height front and back

Put the machine onto a flat and stable surface (such as a work bench) and put blocks beneath the cutting deck:

- at the front 26 mm (1)
- at the rear 32 mm (2)

Put the cutting height adjustment lever into the notch at position «1» and loosen the nuts (3 - 5 - 7) and the locknuts (4 - 6 - 8) so that the deck rests firmly on the blocks.

Screw down the nut (3) until the front part of the cutting deck starts to rise, then tighten the relevant locknut (4) in order to create a fixed reference point for the following stages.

Turn the nut (5) so that it presses on the pin (9) and causes the rod (10) to move forward until all free

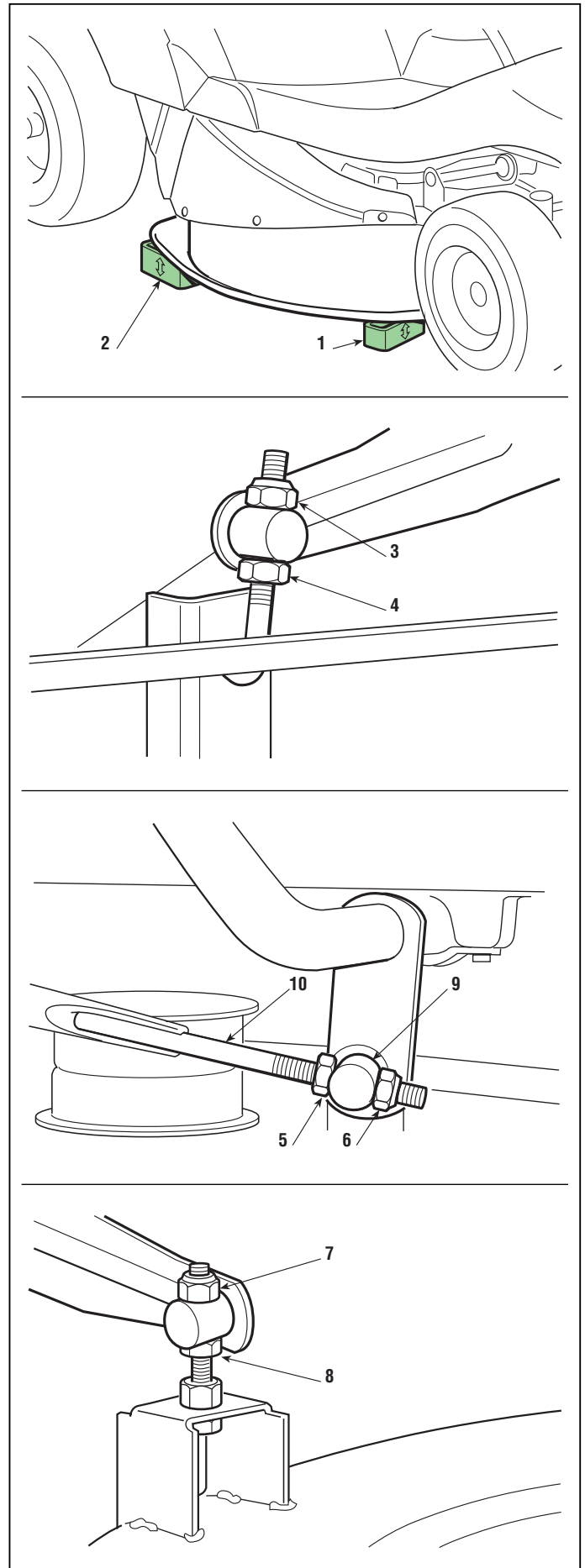

 	<b>4.6.0</b> <b>ALIGNING THE CUTTING DECK</b>	 	from 1998 to page  2 / 2
--	--	--	--

movement is eliminated and the front right of the deck begins to rise.

Having checked that the rod has no possibility of longitudinal movement, tighten the locknut **(6)**. Screw down the nut **(7)** of the transverse adjuster until the front left begins to rise, and then tighten the locknut **(8)**.

### **B) Adjusting the parallel across the cutting deck alone**

Any difference in height from the ground between the left and right sides of the deck can be compensated by turning the nut **(7)** and the locknut **(8)** at the front left coupling point.

#### **NOTE**

Remember to tighten all the nuts and locknuts once these adjustments have been made, leaving the necessary free rotation movement to the pins [see 2.6.B].

## 4.7.0 STEERING ALLOWANCE ADJUSTMENT

from 1998 to

page 1 / 2

### 4.7 STEERING ALLOWANCE ADJUSTMENT

*The steering allowance should never be excessive if driving is not to be impaired.*

Check that the movement is not caused by loose linkage nuts and tighten all the nuts of the tie-rods and ball joints.

If the movement is in the pinion to ring gear coupling, the height of the ring gear will need to be adjusted by inserting spacers inside the hub.

➤ Remove the front and rear protection cover of the steering column [see 5.1].

➤ Remove the footboard [see 5.2].

Unhook the spring (1) and lift the steering column (2) far enough to be able to take out the pin (3) and the pinion (4).

Undo the screw (5) and take out the ring gear (6). Put one or two 11 x 17 x 0.5 mm spacers (7) (according to requirements) inside the hub so that the ring gear is raised higher than the pinion.

Line up the front wheels and refit the ring gear (6) with the arrow pointing forwards, then fully tighten the screw (5).





Turn the steering column so that the hole of the pin (3) is at right angles to the longitudinal axis of the machine, and then fit the pinion (4) so that the pin is fully inserted in its seat.

Push the end of the steering column (2) right down in the hole of the bush (8), check that the teeth of the ring gear in the new position are correctly meshed with those of the pinion and finally, refit the washer (9) and the spring (1).

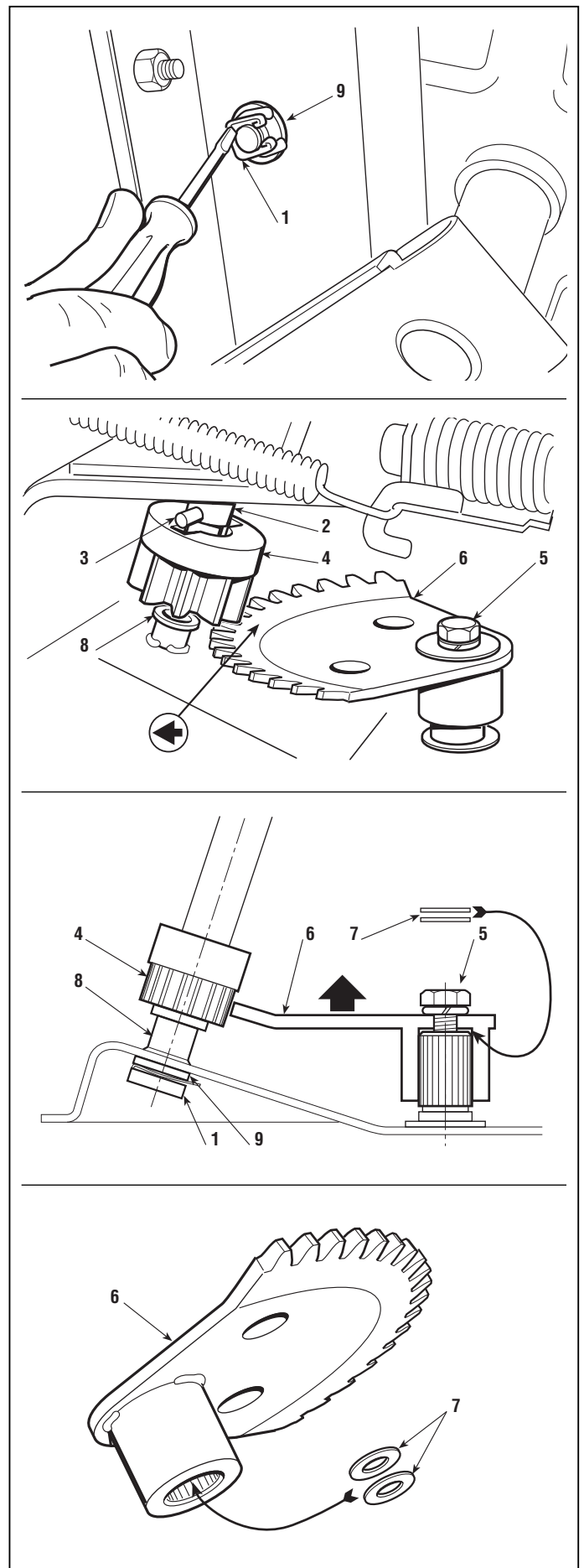
If the movement is still there after having removed all the spacers, check it and if necessary, replace the ring gear/pinion unit [see 6.3], or look for other possible causes.





 	<b>4.7.0</b> <b>STEERING ALLOWANCE ADJUSTMENT</b>	 	from 1998 to page  2 / 2
--	--	--	--

When all parts have been fitted, ...

- Fit the footboard [see 5.2].
- Fit the front and rear protection covers for the steering column and the footboard [see 5.1].

### Tightening torque

<b>5</b>	Ring gear fixing screw .....	25 ÷ 30 Nm
----------	------------------------------	------------

## 4.8.0 STEERING GEOMETRY ADJUSTMENT

from 1998 to

page 1 / 1

### 4.8 STEERING GEOMETRY ADJUSTMENT

The correct steering geometry is given by the distances between centres of the two tie-rods connecting the wheels. Any faults caused by knocks or accidents result in reduced driving precision and increased wear on the tyres.

These can be overcome as follows:

- uneven or excessive wear on the front tyres = toe-in adjustment,
- the machine does not maintain a straight line when the steering wheel is straight = adjustment of tie-rods.

#### NOTE

Before any other action, check that the ball joint connections have not become loose.

#### A) Toe-in adjustment

The exact toe-in is obtained when there is a distance of 429 - 431 mm measured between the two centres of the stub axle joints (1) which is obtained when the distance between the joints of the two tie-rods (1 - 2) is 200.5 - 201.5 mm [see 8.2.3].

If the amount is different to this, check if the error is due to one or both of the tie-rods. Dismantle the part concerned, loosen the locknut (3) and screw the joint up or down on the rod (4) until achieving the exact amount.

#### NOTE

The two tie-rods must always be adjusted to the same length.

On fitting, fully tighten the locknuts (3) and the nuts (5) fastening the joints.

#### B) Adjusting the steering wheel position

Firstly check the toe-in (point "A") and align the front wheels.

If the steering wheel is not straight, check that both tie-rods have the same distance between the joints (1 - 2) (200.5 - 201.5 mm) [see 8.2.6].

Having identified the part that has a different length, adjust as indicated in point "A".

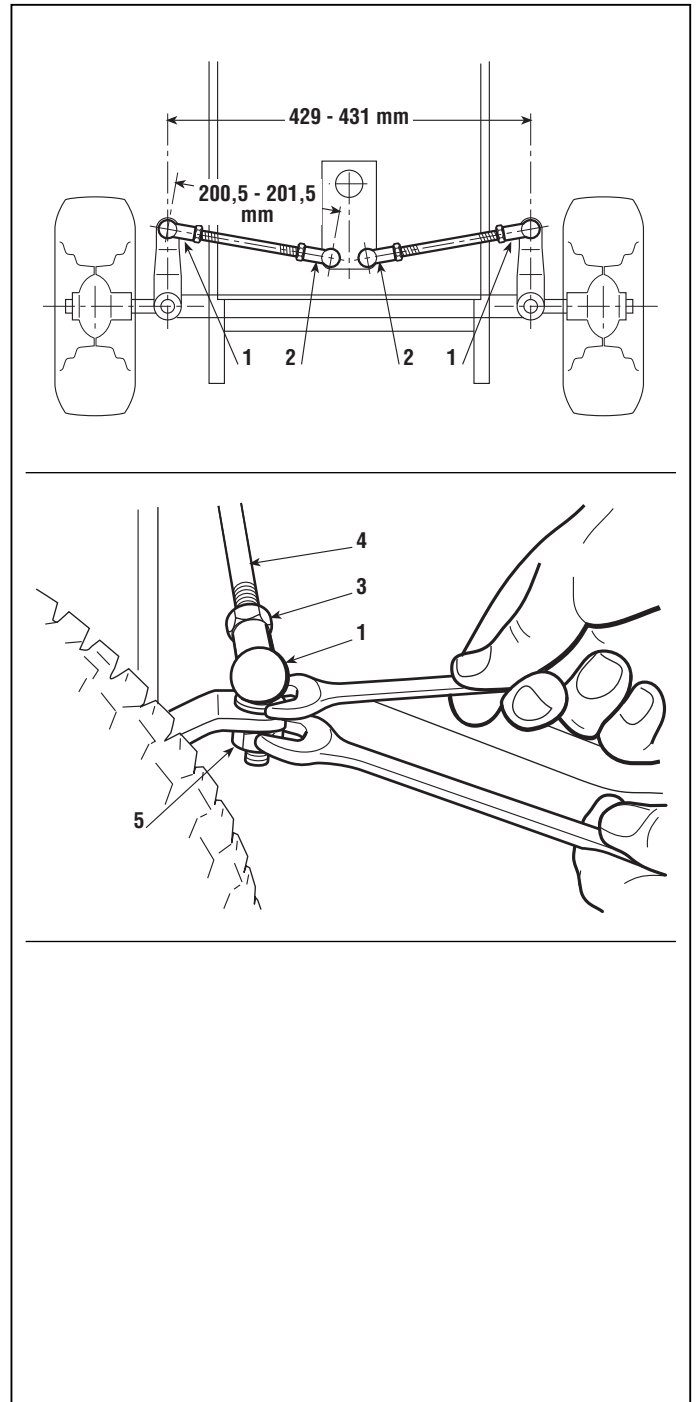

On fitting, fully tighten the locknuts (3) and the nuts (5) fastening the joints.

When the adjustment has been made, check the toe-in as described at point "A".

#### Tightening torques

- |   |            |
|---|------------|
| 3 Locknuts for articulated joints       | 25 ÷ 30 Nm |
| 5 Fastening nuts for articulated joints | 45 ÷ 50 Nm |

## 4.9.0 CHECK ON BLADE ALIGNMENT

from 1998 to

page 1 / 1

### 4.9 CHECK ON BLADE ALIGNMENT

*Excessive vibration when cutting and an uneven cut can be due to misalignment of the blade owing to deformation of the flange or the shaft as a result of accidental knocks.*

➡ Place the machine on its side [see 2.4].



**Always wear strong gloves when handling the blade.**

Disengage the blade, place a straight metal rod (1) on a point around the edge of the deck (2), turn the blade by hand and check the distance between the rod and the two ends "A" and "B". The distance should be the same, and any difference should not exceed 2 - 3 mm.

If higher amounts are found, check that the blade is not distorted. If this is not the case, check the support or the shaft for the blade [see 6.6], replacing if necessary, and check the condition of the point where the flange rests on the cutting deck.



**IMPORTANT!**

**Always replace a damaged blade and do not attempt to repair or straighten it. Always use manufacturer's genuine spare parts!**

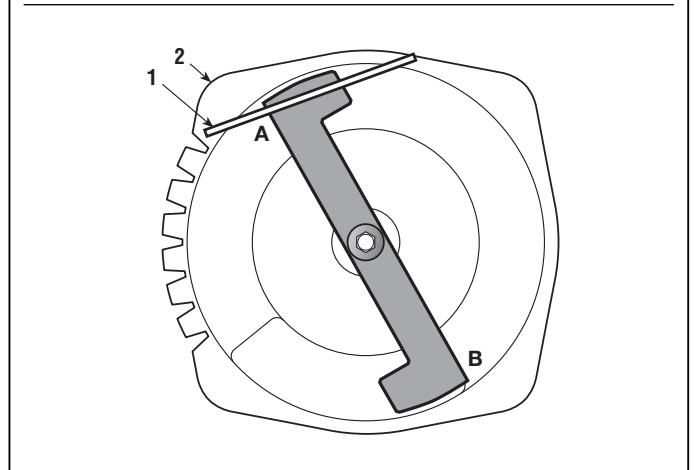
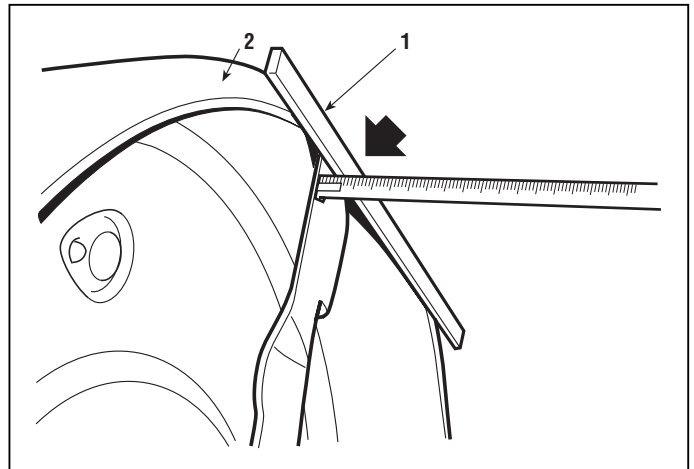

## 4.10.2 - REMOVING, SHARPENING AND BALANCING THE BLADE

from 1998 to

page 1 / 1

### 4.10 REMOVING, SHARPENING AND BALANCING THE BLADE

*A badly sharpened blade causes grass to become yellow and reduces grass collection capability. If not balanced, excessive vibration can be caused during use.*



**Always wear protective gloves when handling the blade and protect eyes when sharpening.**

#### A) Removing and reassembling

For removing a blade it must be firmly held and the central screw (1) undone.



On assembly, be careful to:

- correctly position the keys (3) on the shafts;
- correctly locate the blade, with the fins facing towards the inside of the plate;
- fit the flexible disc (4) so that the concave part is pressing against the knife;
- tighten the screw (1) with a torque wrench set to 45-50 Nm.

#### B) Sharpening and balancing

Always sharpen both cutting edges of the blade (2) using a medium grade grinder. Sharpening must only be done from the rounded side, removing as little as possible.

The blade is to be replaced when the cutting edge has worn down to 10 mm.

Using the appropriate equipment, check the balance to make sure that there is a maximum difference of 1 gram between one side and the other.

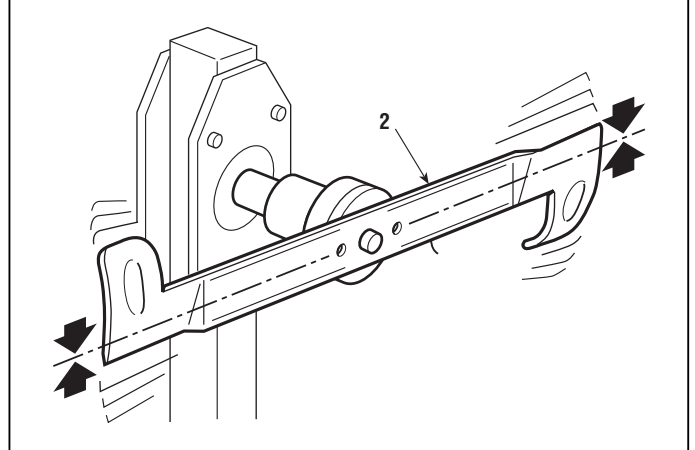
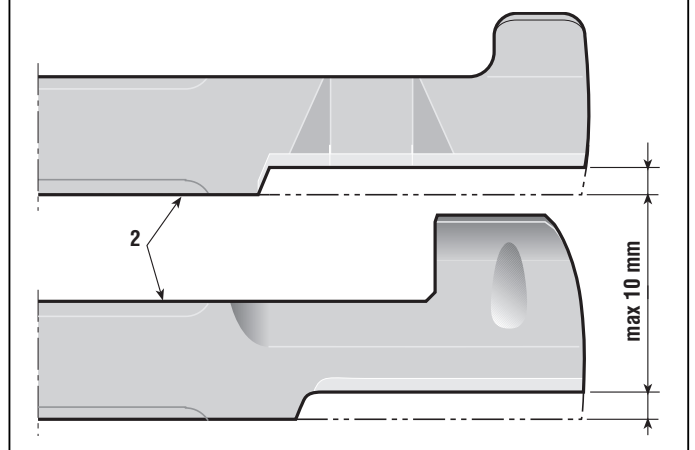
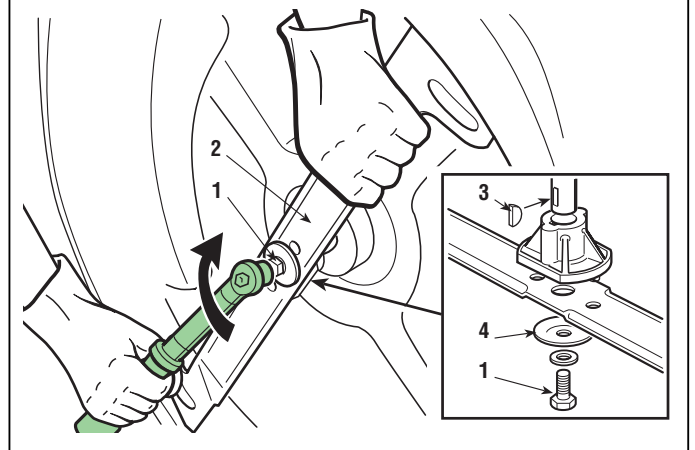
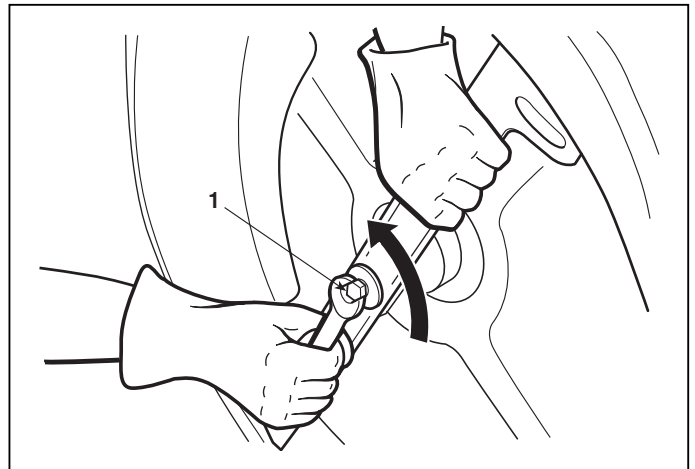

#### Tightening torque

1 Screw for blade ..... 45 ÷ 50 Nm

4.11.1	from 1999 to
<b>ADJUSTMENT OF THE COLLECTOR CHANNEL GUIDE</b>	page 1 / 1

## 4.11 ADJUSTMENT OF THE COLLECTOR CHANNEL GUIDE

*This adjustment is to be made after any work on the collector channel guide and if the rear plate has been dismantled.*

*The importance of this adjustment is in avoiding that incorrectly inserting the channel opening in the hole in the plate prevents the wheels cover [see 2.5] from closing properly which could let grass cuttings get into the engine housing causing damage.*

➡ Fit the channel [see 5.5].

Take the cutting deck to position «1». In this condition, the channel (1) should be properly sitting in the guide (2).

If the guide is lower or tends to raise the channel too much, loosen the screw (3) and make the guide slide until it is repositioned correctly. Always check that, when the wheels cover is closed according to the regular procedure [see 2.5], the channel always inserts in the hole of the plate regularly and automatically, and with no need to help it in manually.

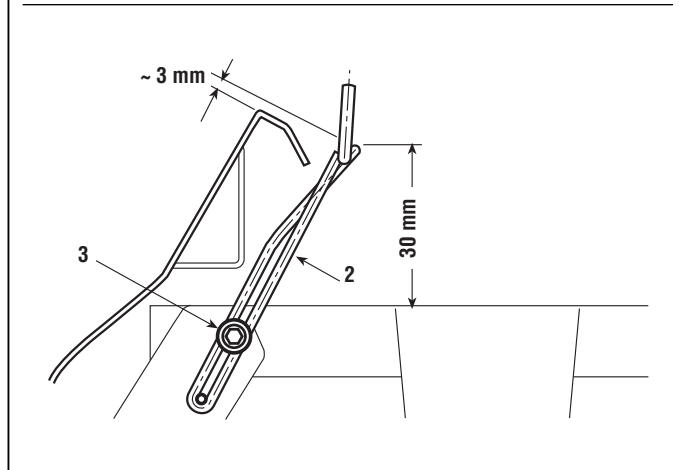
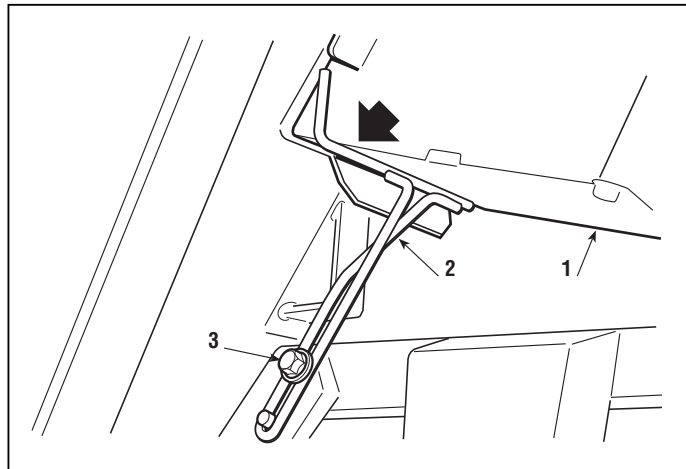

## 5.1.1 - REMOVAL OF THE STEERING COLUMN PROTECTION COVER

from 1999 to

page 1 / 1

### 5.1 REMOVAL OF THE STEERING COLUMN PROTECTION COVER

*Removing the front protection cover of the steering column gives better access to:*

- the battery

Remove the rear protection **(1)**, held by two side screws **(2)**.

Dismantle the starter unit **(3)** and take out the signal LED **(4)**.

Dismantle the steering wheel **(5)** after having removed the pin **(6)** using a punch.

Undo the two side screws **(7)**. The front protection cover **(8)** can be taken out from the top.

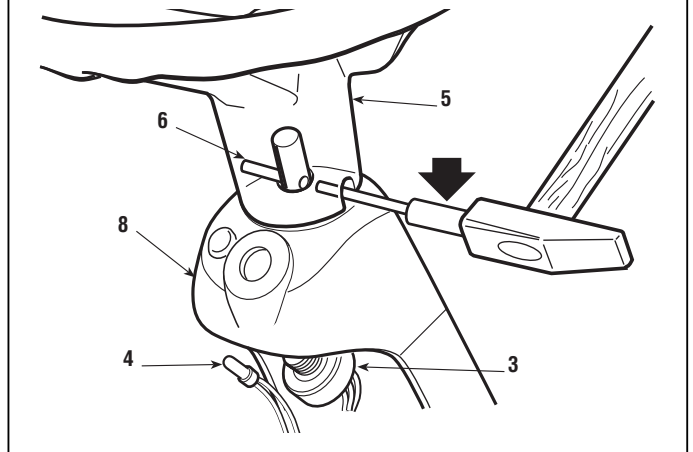
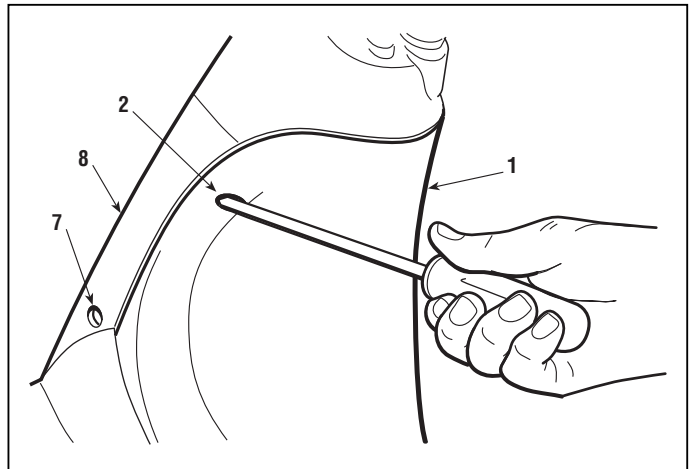

## 5.2.0 REMOVAL OF THE FOOTBOARD

from 1998 to

page 1 / 1

### 5.2 REMOVAL OF THE FOOTBOARD

Removing the footboard gives access to:

- the pinion and the ring gear of the steering.

- ➡ Remove the steering column protection cover [see 5.1].

Dismantle the pedal **(1)** by unscrewing the two nuts **(2)**, and unscrew the knob **(3)** of the parking brake.

Unscrew the nut **(4)** to slightly lift the wheels cover **(5)**.

The footboard **(6)** is held to the frame by four internal screws **(7)** and four longer external screws **(8)** with washers **(9)** for resting on the tubular support element.

On refitting, reverse the order of the previous steps, remembering to put the washers **(9)** under the screws **(7)** and lastly, ...

- ➡ Refit the protection covers on the steering column [see 5.1].

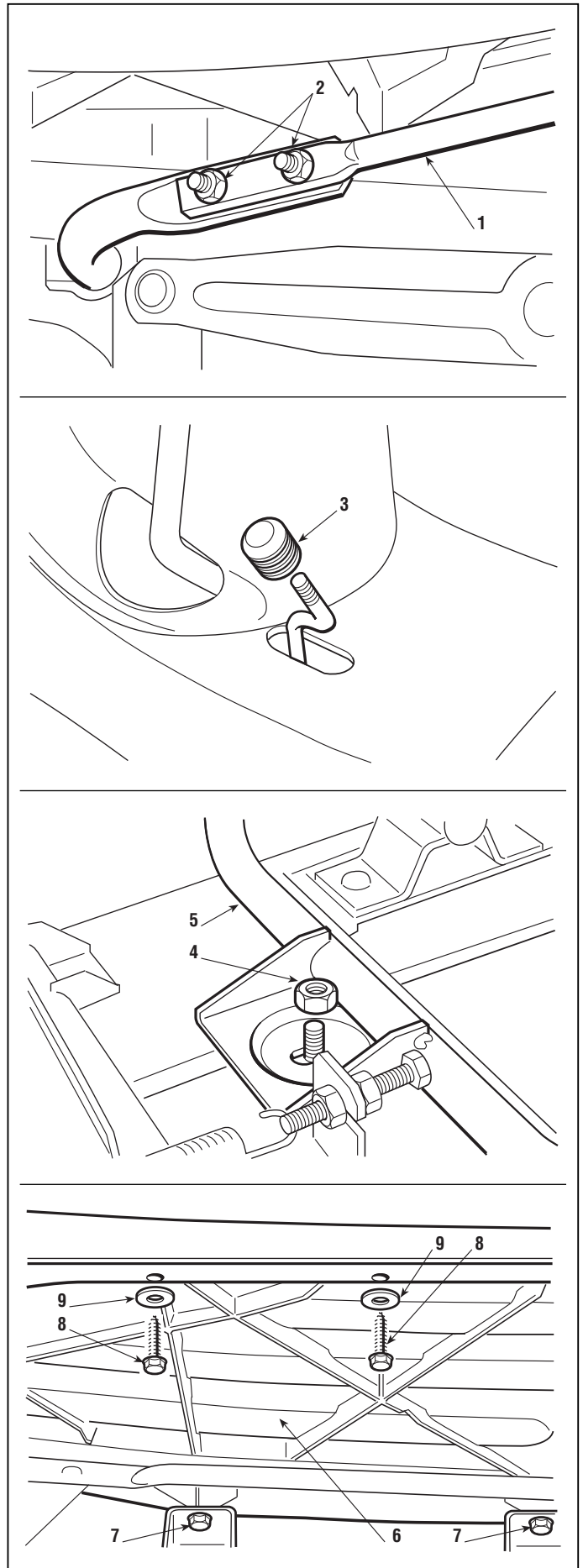

### Tightening torque

**7-8** Self-threading screws for the footboard .... 6,5 Nm

## 5.3.3 REMOVAL OF THE WHEELS COVER

from 2003 to

page 1 / 1

### 5.3 REMOVAL OF THE WHEELS COVER

Removing the wheels cover may be necessary for:

- improving access around the engine,
- removing the rear plate.

➔ Replace the accelerator from the wheel cover side [see 6.7].

➔ Release the seat safety cable (if installed) from the wheel cover side [see 6.12].

Unscrew the lever knob (2).

Take out the split pin (3) and remove the pin (4) to dismantle the seat.

Release the spring (5) of the fixed cover of the grass-catcher (6), by undoing the screws (7) which hold on the small plate (8).

Undo the two self-threading screws (9) and loosen the two screws (10) with nuts that hold the cover onto the rear plate.

➔ Lift the wheels cover [see 2.5].

Undo the six screws which attach the tubular element. Two of them are short (11) and four are longer (12) and they can be reached from below.



When reassembling, do not forget to reattach the connector of the seat microswitch and to make sure it works.

➔ Close up the wheels cover [see 2.5].

#### Tightening torques

9-11-12 Self-threading screws for wheels cover ..... 6,5 Nm

10 M6 screws for wheels cover ..... 8 ÷ 10 Nm

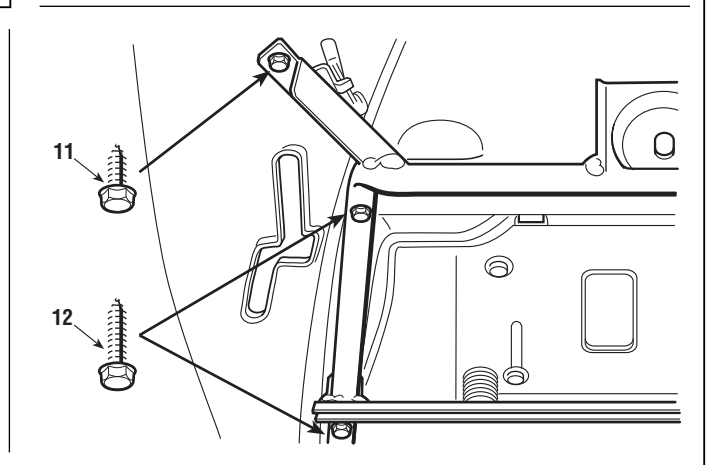
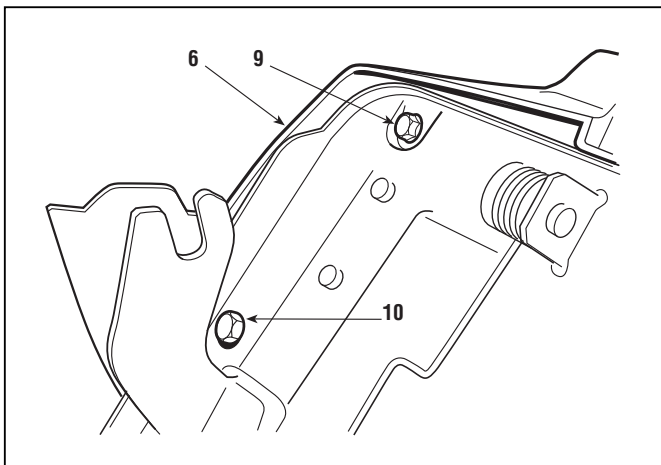
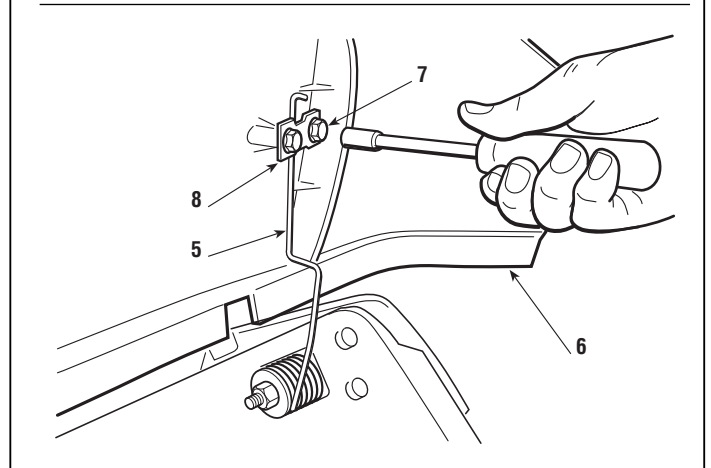
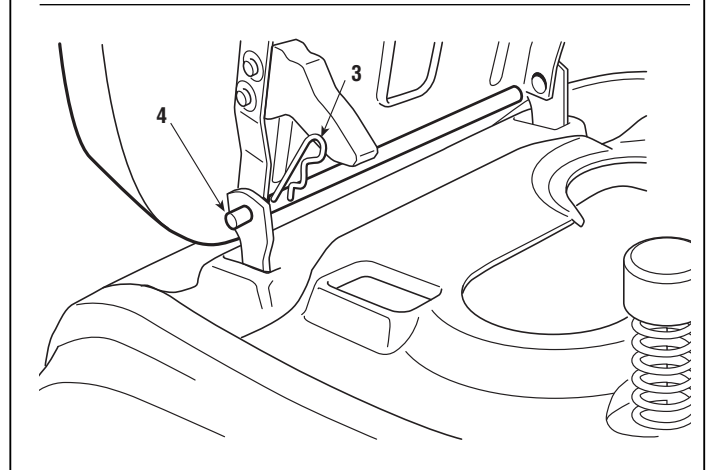
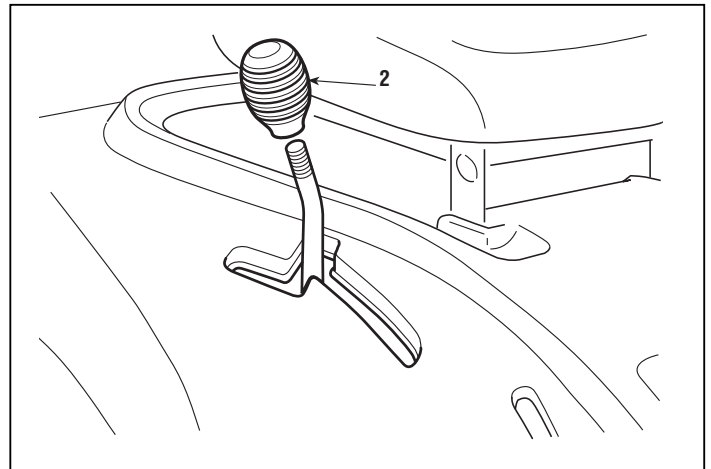



## 5.4.1 REMOVAL OF THE REAR PLATE

from 2001 to

page 1 / 2

### 5.4 REMOVAL OF THE REAR PLATE

*The rear plate does not need to be removed for access to other parts for work. The following procedure is only for replacing with a new one.*

➡ Remove the wheels cover [see 5.3].

Close up the frame of the cover, tightening the fixing nut **(1)**.

Detach the electrical connections from the “grass-catcher attached” microswitch **(2)** and the “grass-catcher full” microswitch **(3)** and release the stop cable **(4)**.

The plate is hinged at the base of the machine's frame by two small plates **(5)**, each of which is fixed by four screws **(6)**, and is attached to the frame of the wheels cover by four screws **(7)**.

First of all, undo the four upper screws **(7)** and then dismantle the two lower plates **(5)**, ensuring that the wheels cover frame has the necessary stability since, by removing the plate, it is without support at the back.

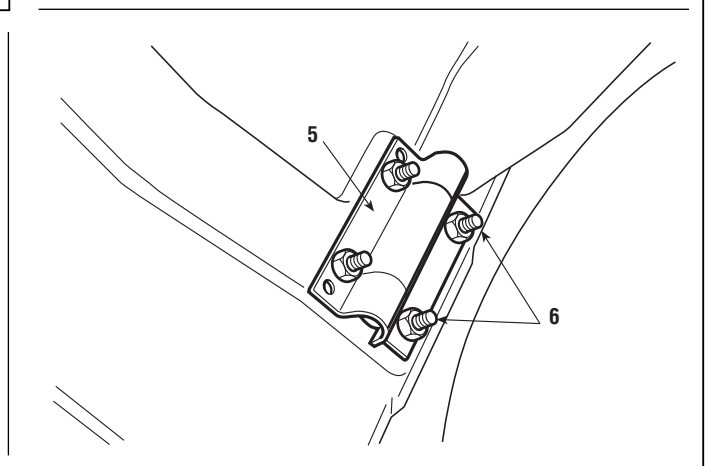
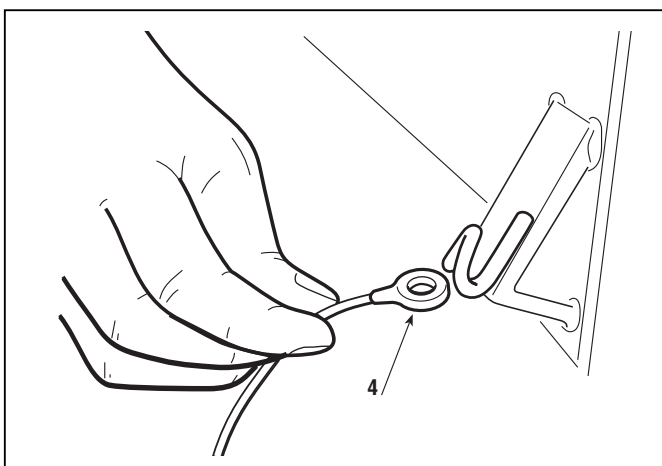
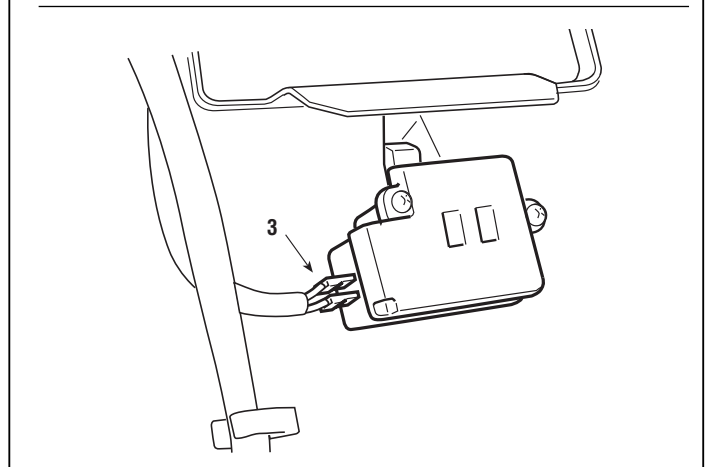
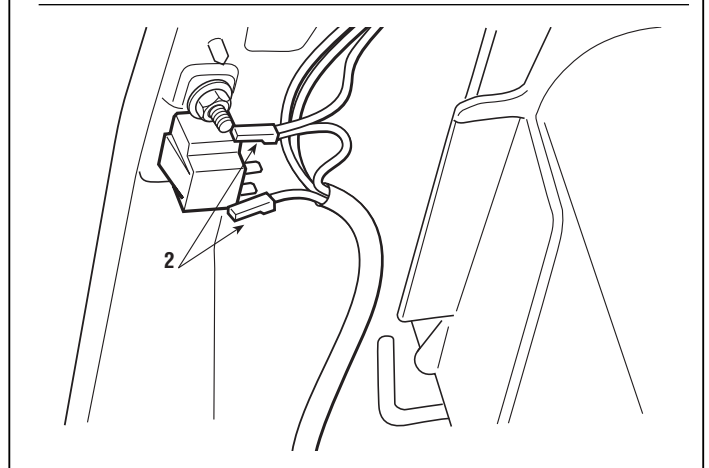
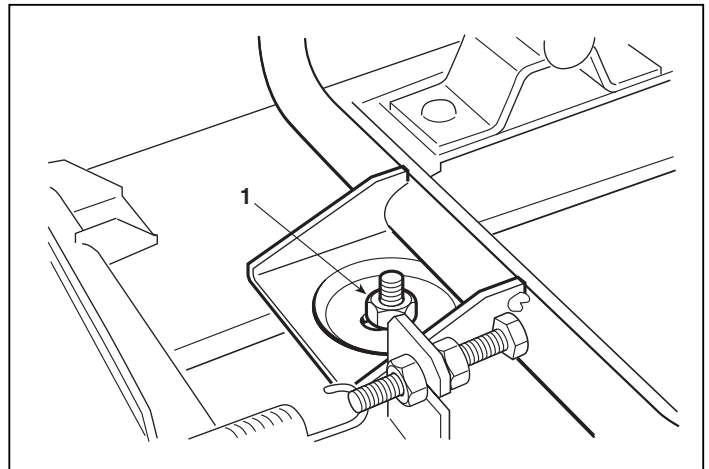



## 5.4.1 REMOVAL OF THE REAR PLATE

▶ from 2001 to  
▶ page ◀ 2 / 2

To reassemble the plate, start from the two hinges below and then attach the upper part of the frame of the wheels cover.



Reattach all the electrical connections and make sure that the microswitch is working.

- Reassemble the wheels cover [see 5.3].
- Check that the channel fits in the opening [see 4.11].

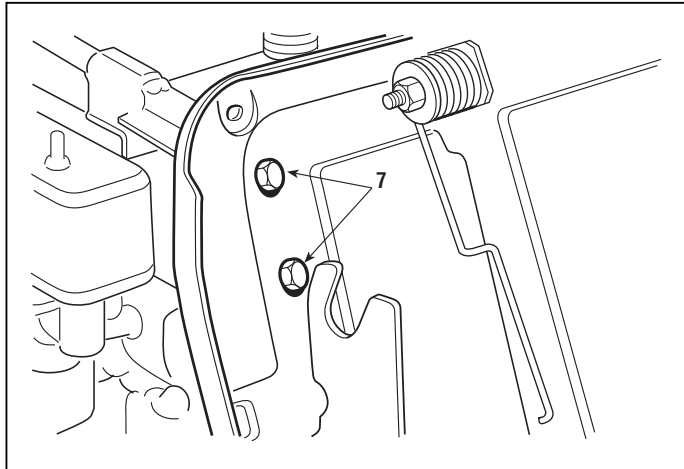

### Tightening torques

- |  |            |
|--|------------|
| <b>6</b> Hinge screws, rear plate .....        | 8 ÷ 10 Nm  |
| <b>7</b> Screws for attaching rear plate ..... | 25 ÷ 30 Nm |

5.5.0 <b>REMOVAL OF THE COLLECTOR CHANNEL</b>	from 1998 to page 1 / 1
--	----------------------------

## 5.5 REMOVAL OF THE COLLECTOR CHANNEL

*Removing the channel is necessary for:*

- *draining oil from the engine,*
- *accessing the right-hand side of the engine.*

➡ Turn back the wheels cover [see 2.5].

The channel **(1)** can be removed by releasing one of the two split pins **(2)** and taking out the pin **(3)**.

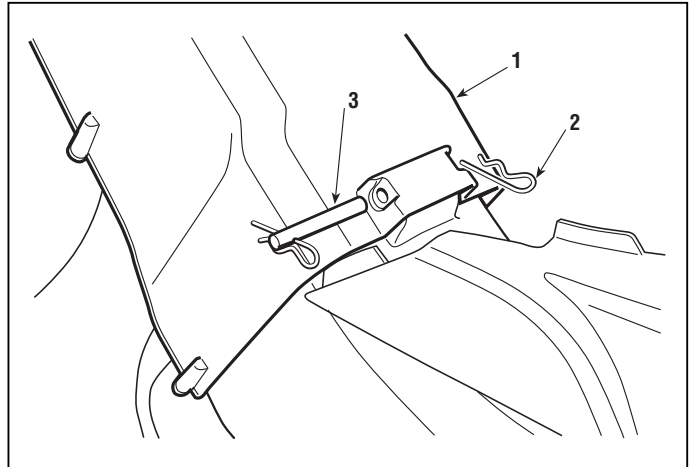

## 5.6.1 REMOVAL OF THE ENGINE

from 2004 to

page 1 / 2

### 5.6 REMOVAL OF THE ENGINE

Since there are different types of drive, the stages described here refer to those shared or similar in all types of engine.

➡ Turn back the wheels cover [see 2.5].

Disengage the blade to loosen the belt. The transmission belt should also be loosened.

This is done by ...

➤ **in mechanical drive models:**  
engaging the parking brake.

➤ **in hydrostatic drive models:**  
releasing the spring (1) of the stretcher.

Undo the central screw (2) and take out the pulley (3) from the shaft.

If it is difficult to take out, use the special extractor inserted into the holes (4) of the pulley, but do not completely undo the screw (2) so that the extractor puts pressure on the head of the screw and does not damage the threaded hole of the shaft.

Remove the protection from the exhaust (5) (differing according to the types of engine), and disconnect the accelerator cable control and all the electrical wires.



Close the fuel cock and detach the fuel pipe, **taking care not to spill fuel.**

Find and undo all the screws holding the engine to the frame, grip the engine firmly and lift it, taking the necessary care bearing in mind that its weight is around 25 - 35 kg.

#### NOTE

Some types of engine are held with screws of different lengths and in different positions, so it is best to label them so that no errors are made when reassembling.

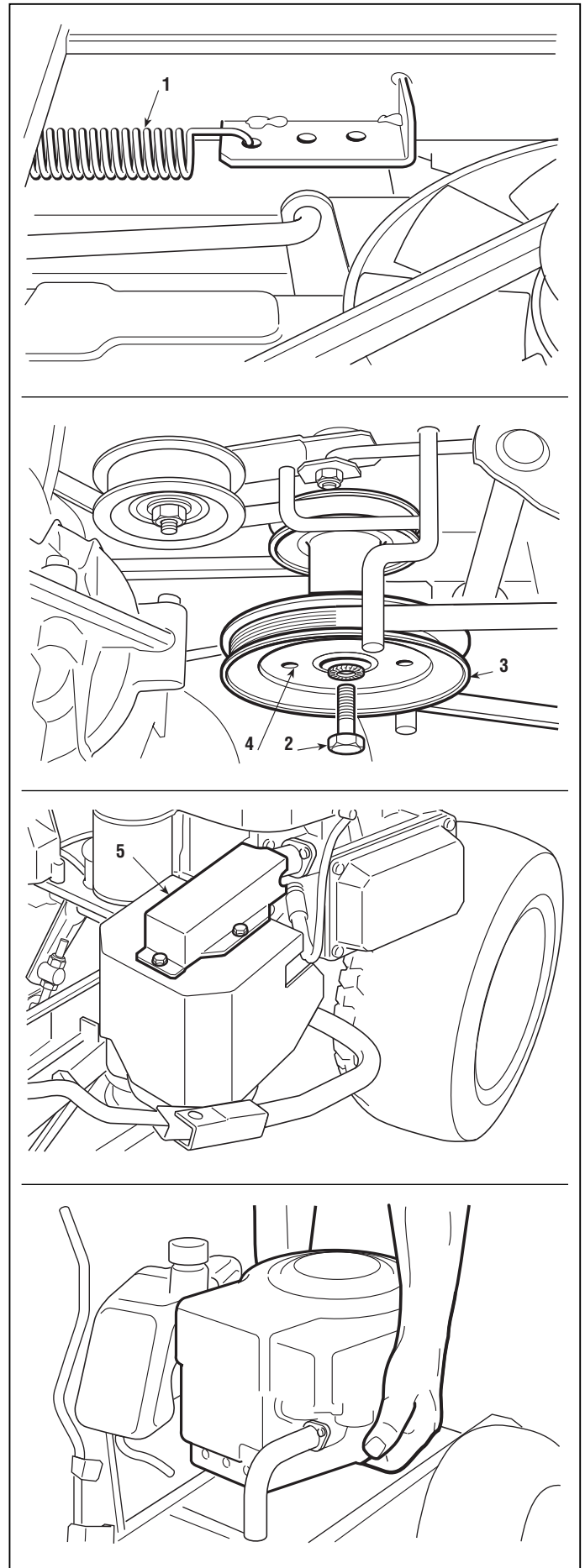

5.6.1 <b>REMOVAL OF THE ENGINE</b>	from 2004 to
	page ◀ 2 / 2

When reassembling, fully tighten the screws for the engine and the pulley to the amounts shown.



Remember to fit the clamp back on the fuel pipe and **check that it does not leak**.

Reattach all the electrical and earth contacts and refit the protection covers **(5)**.

► **for hydrostatic drive models:** refit the spring **(1)** of the stretcher.

Reattach the accelerator cable and ...

☛ Adjust the «MINIMUM» position [see 6.7].

☛ Close up the wheels cover [ see 2.5].

### Tightening torque

1 Screw for engine pulley. ....	45 ÷ 50 Nm
- Screws for engine fastening .....	25 ÷ 30 Nm

## 5.7.6 - REMOVAL OF THE REAR AXLE (Dana 4360-210)

from 2008 to

page 1 / 2

### 5.7 REMOVAL OF THE REAR AXLE (Dana 4360-210)

The rear axle (Transaxle) is made up of single maintenance-free sealed unit which includes the transmission unit (mechanical) and the differential. It only needs to be removed to be replaced or for an overhaul by the Manufacturer's Service Centre.

➡ Lift the wheels cover [see 2.5].

➡ Dismantle the engine pulley [see 5.5] to release the belt.

Place two spacers **(1)** of approximately 150 mm under the two ends of the rear plate.

➡ Remove the rear wheels [see 6.1].

Engage the parking brake to slacken off the transmission belt and remove the pin **(2)** from the brake rod **(3)**.

Disconnect the control rod **(4)** of the gear-change by taking out the split pin **(5)**, and disconnect the wires of the microswitch **(6)** for signalling the "neutral" position.

Also dismantle the pulley **(7)** held by a snap ring **(8)**.

The unit is supported by two brackets **(9)** – depending on the type used – with their screws **(10)** and **(11)** and is fastened to the frame **(12)** by four screws **(13)**.

Loosen the screws **(11)** to permit a minimum of movement of the brackets **(9)** and undo the screws **(10)**. Then carefully undo the four lower screws **(13)**, giving sufficient support to the unit so that it does not fall, bearing in mind its weight of around 15 - 22 kg.

Reassemble in the reverse order, being particularly careful with the two self-tapping screws **(10)** which, if not screwed in correctly, can damage the internal thread preventing correct fastening.

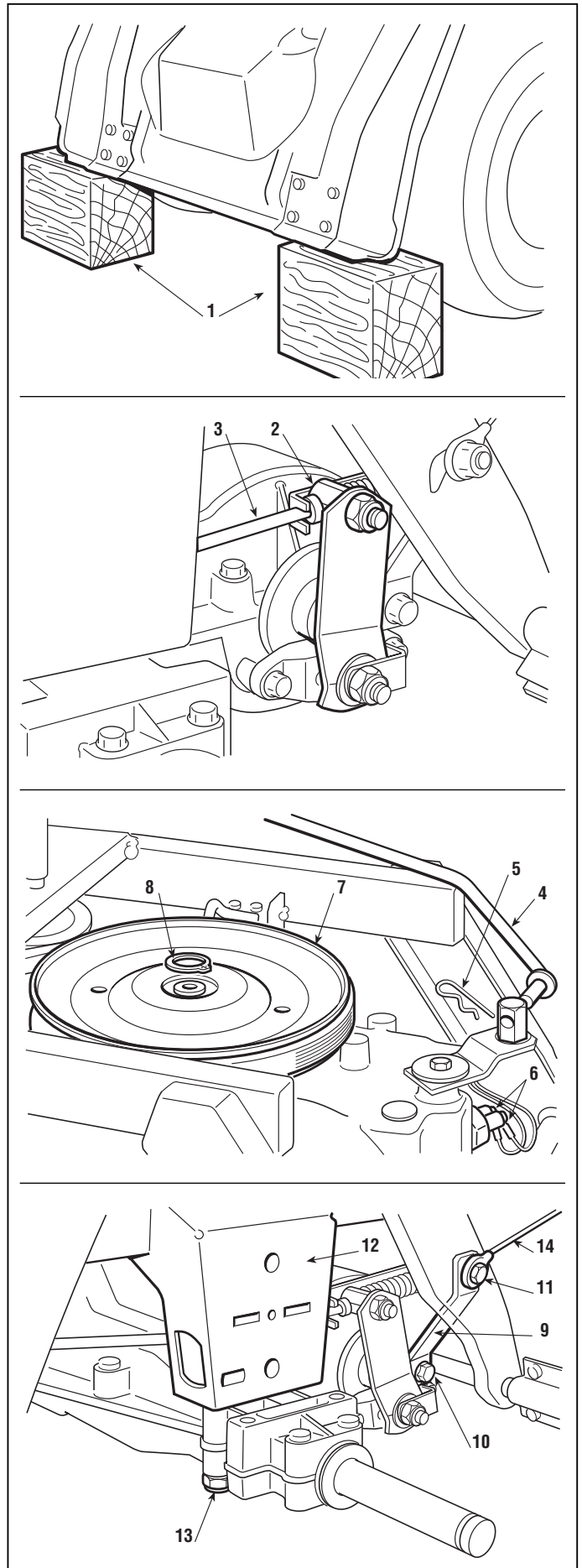

## 5.7.6 - REMOVAL OF THE REAR AXLE (Dana 4360-210)

from 2008 to

page 2 / 2

### NOTE

When tightening the screw **(11)** on the left-hand side, be careful with the stop cable **(14)**, which must always be taut and straight when the cover is open.

Check that the spacers **(15 - 16 - 17 - 18)** are correctly fitted to the shafts, in the sequence given.

Reattach all the connections, and then ...

- ☛ Check the brake [see 4.3]
- ☛ Refit the engine pulley [see 5.5] to release the belt.
- ☛ Refit the rear wheels [see 6.1].
- ☛ Lift the wheels cover [see 2.5].

If the control rod has been replaced or completely dismantled...

- ☛ Adjust the travel and the position of “neutral” for the lever [see 4.5.A].



### IMPORTANT

If you decide to install a Dana unit to replace a unit produced by another Manufacturer, it is ALWAYS necessary to also replace:

- the gear control shaft **(4)**;
- the fastening screws **(13)**;
- the spacers **(15 - 16 - 17 - 18)**;

as indicated in the Spare parts catalogue.

Furthermore, ALWAYS:

- ☛ Proceed with the brake adjustment [see 4.3]
- ☛ Adjust the drive engagement [see 4.4].

### Tightening torques

<b>10</b> Self-tapping screws .....	25 ÷ 30 Nm
<b>11</b> Screws for brackets .....	25 ÷ 30 Nm
<b>13</b> Screws for rear axle fastening .....	25 ÷ 30 Nm

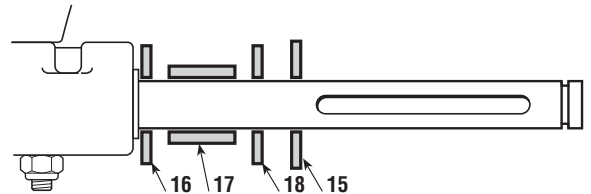

## 5.7a.4 - REMOVAL OF THE REAR AXLE (Tuff Torq K46T)

from 2006 to

page 1 / 2

### 5.7a REMOVAL OF THE REAR AXLE (Tuff Torq K46T)

The rear axle (Transaxle) is made up of single maintenance-free sealed unit which includes the transmission unit (hydrostatic) and the differential. It only needs to be removed to be replaced or for an overhaul by the Manufacturer's Service Centre.

➔ Lift the wheels cover [see 2.5].

➔ Dismantle the engine pulley [see 5.5] to release the belt.

Place two spacers **(1)** of approximately 150 mm under the two ends of the rear plate.

➔ Remove the rear wheels [see 6.1].

Disconnect the drive control rod **(21)** by removing the split pin **(22)**, remove the pin **(23)** from the brake rod **(24)** unscrewing nut **(25)**; move the tensioner guide pulley **(26)** to the right and free the pulley **(27)** from the belt **(28)**.

Disconnect the transmission release control rod **(29)**, held by a bevel fastener **(30)**.

The group is supported by a support **(31)** fixed by a

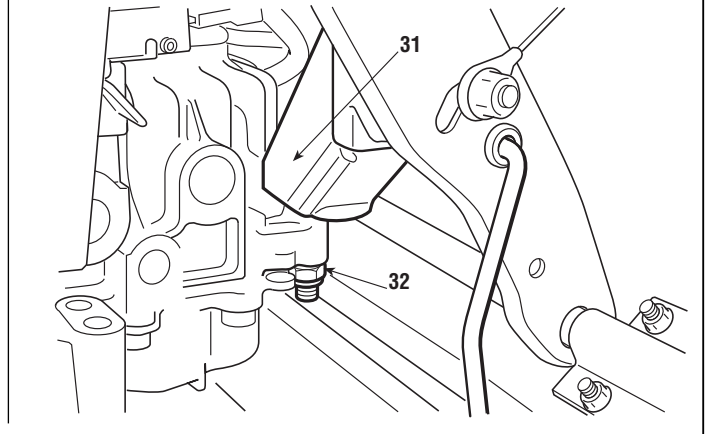
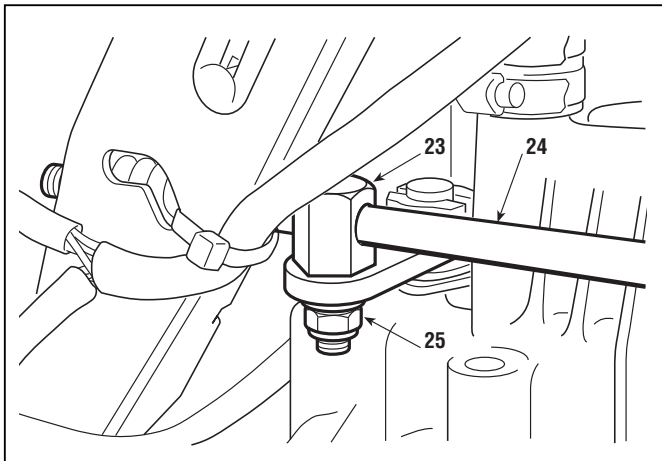
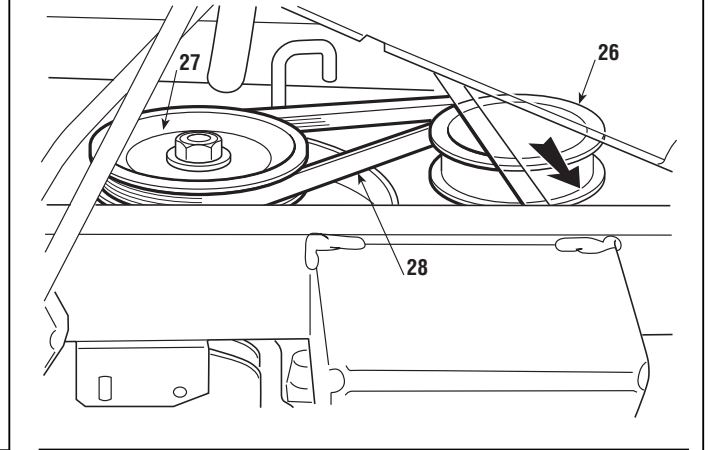
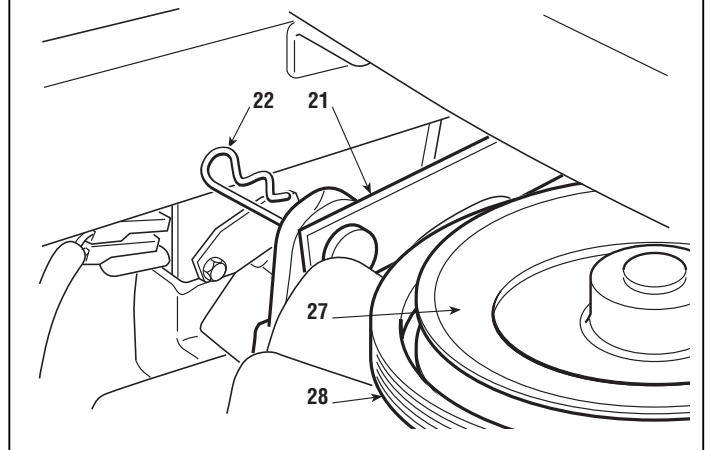
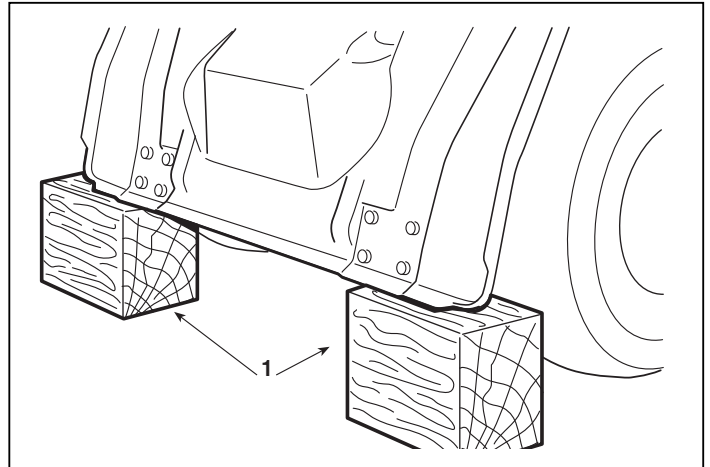



## 5.7a.4 - REMOVAL OF THE REAR AXLE (Tuff Torq K46T)

from 2006 to  
page 2 / 2

screw with nut (32) and is fixed to the chassis by four screws with relative nuts (33).

Unscrew nut (32), then carefully unscrew the nuts (33) of the four lower screws, suitably supporting the group so it cannot fall and taking account of the weight of approximately 20 - 22 kg.

Carry out the above operations in reverse to reassemble.

### NOTE

When the transmission release control rod (29) is reconnected, the bevel fastener (30) must always be replaced since it is damaged during dismantling ➡ [see 2.6.C].

Check that the spacers (35 - 37- 37) are correctly fitted to the shafts, in the sequence given.

Reattach all the connections, and then ...

- ➡ Check the brake [see 4.3]
- ➡ Refit the engine pulley [see 5.5] to release the belt.
- ➡ Refit the rear wheels [see 6.1].
- ➡ Lift the wheels cover [see 2.5].

If the control rod has been replaced or completely dismantled...

- ➡ Adjust the travel and the position of "neutral" for the lever [see 4.5.A].

### Tightening torques

25	Brake pin fastening nut .....	25 ÷ 30 Nm
32	Rear axle support nut .....	25 ÷ 30 Nm
33	Rear axle fastening nuts .....	25 ÷ 30 Nm

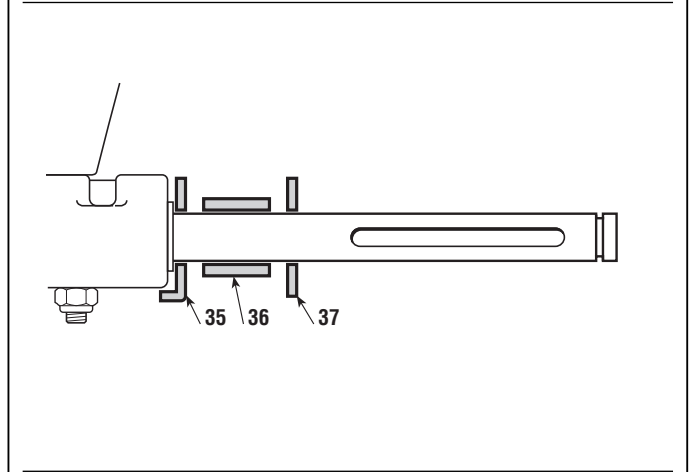
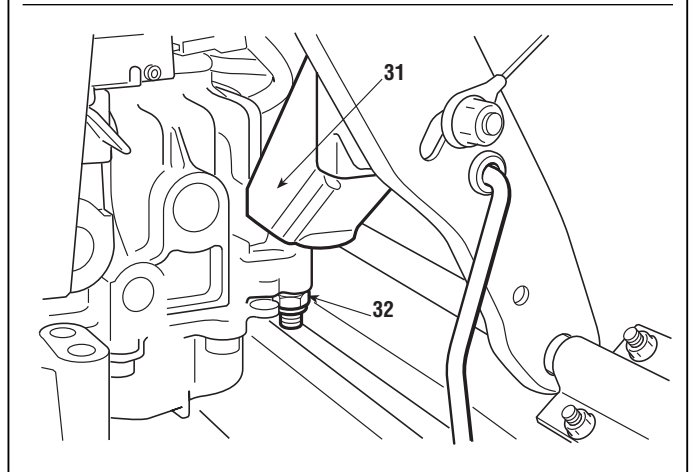
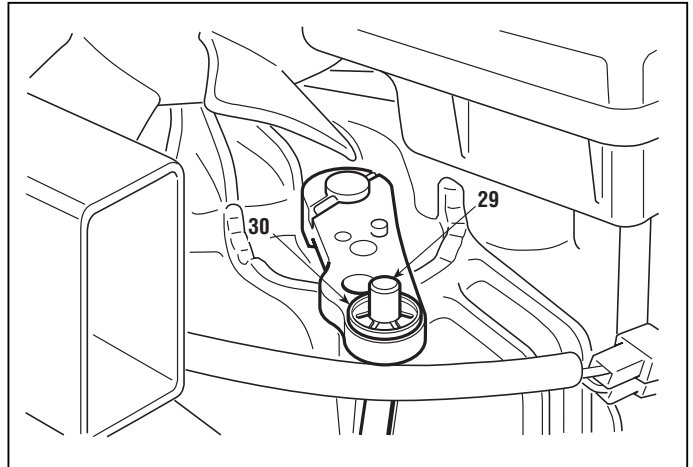

## 5.7c.0 - REMOVAL OF THE REAR AXLE (Hydro Gear)

from 2010 to

page 1 / 2

### 5.7c REMOVAL OF THE REAR AXLE (Hydro Gear)

The rear axle (Transaxle) is made up of single maintenance-free sealed unit which includes the transmission unit (hydrostatic) and the differential. It only needs to be removed to be replaced or for an overhaul by the Manufacturer's Service Centre.

➤ Lift the wheels cover [see 2.5].

➤ Dismantle the engine pulley [see 5.5] to release the belt.

Place two spacers **(1)** of approximately 150 mm under the two ends of the rear plate.

➤ Remove the rear wheels [see 6.1].

Remove the split pin and remove the front pin **(1)** from the brake rod.

Unscrew the nuts **(3)** and **(4)** and remove all the brake adjuster unit components **(5)** so that the rod **(6)** is free to slide forward.

Release the plate **(7)** and slide the pin **(8)** out to disconnect the drive control rod **(9)**

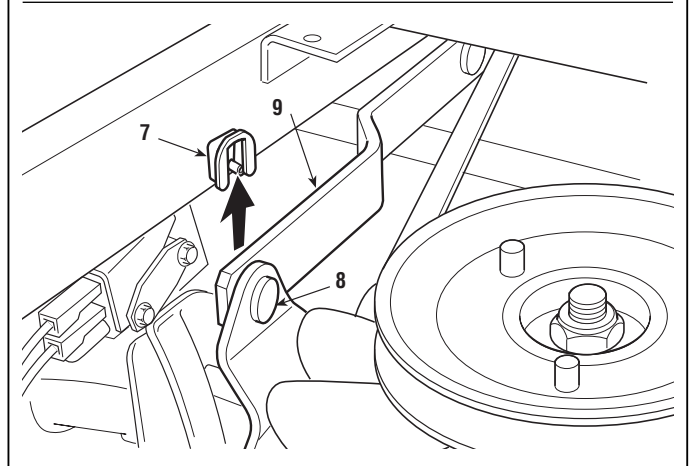
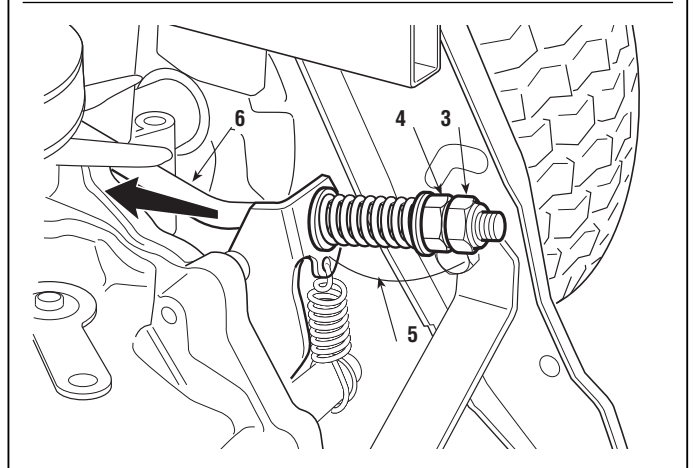
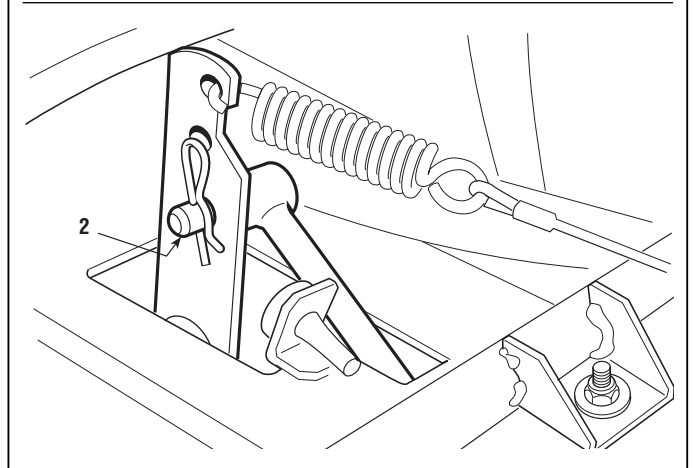
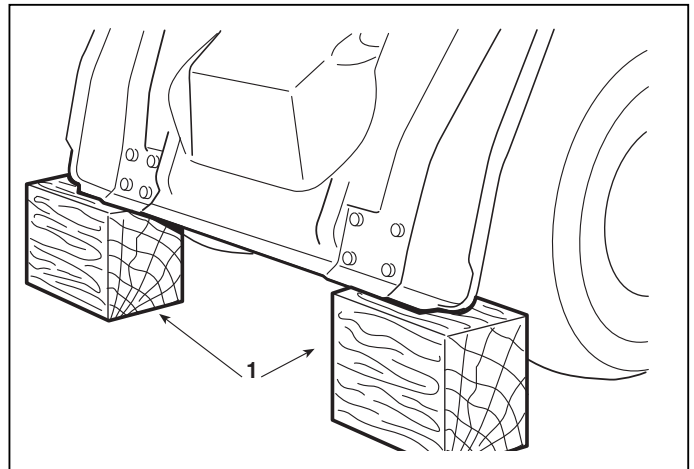

## 5.7c.0 - REMOVAL OF THE REAR AXLE (Hydro Gear)

from 2010 to  
page 2 / 2

Release the spring (10), slide off the splint pin (11) and disconnect the transmission release control rod (12).

The group is supported by a support (13) fixed by a screw with nut (14) and is fixed to the chassis by four screws with relative nuts (15).

Loosen the nut (16) to allow a minimum of movement for the support (13), unscrew the nut (14), then carefully unscrew the nuts (15) on the four lower screws, suitably supporting the group so it cannot fall and taking into account it weighs approximately 15 - 22 kg.

To reassemble, reverse the order of the previous operations.

Check that the spacers (17 - 18) are correctly fitted to the shafts.

Reattach all the connections, and then ...

- ☛ Check the brake [see 4.3]
- ☛ Refit the engine pulley [see 5.5] to release the belt.
- ☛ Refit the rear wheels [see 6.1].
- ☛ Lift the wheels cover [see 2.5].
- ☛ Adjust the travel and the position of "neutral" for the lever [see 4.5.A].

### Tightening torques

<b>14-16</b> Screws for support fastening ....	25 ÷ 30 Nm
<b>15</b> Rear axle fastening nut .....	25 ÷ 30 Nm

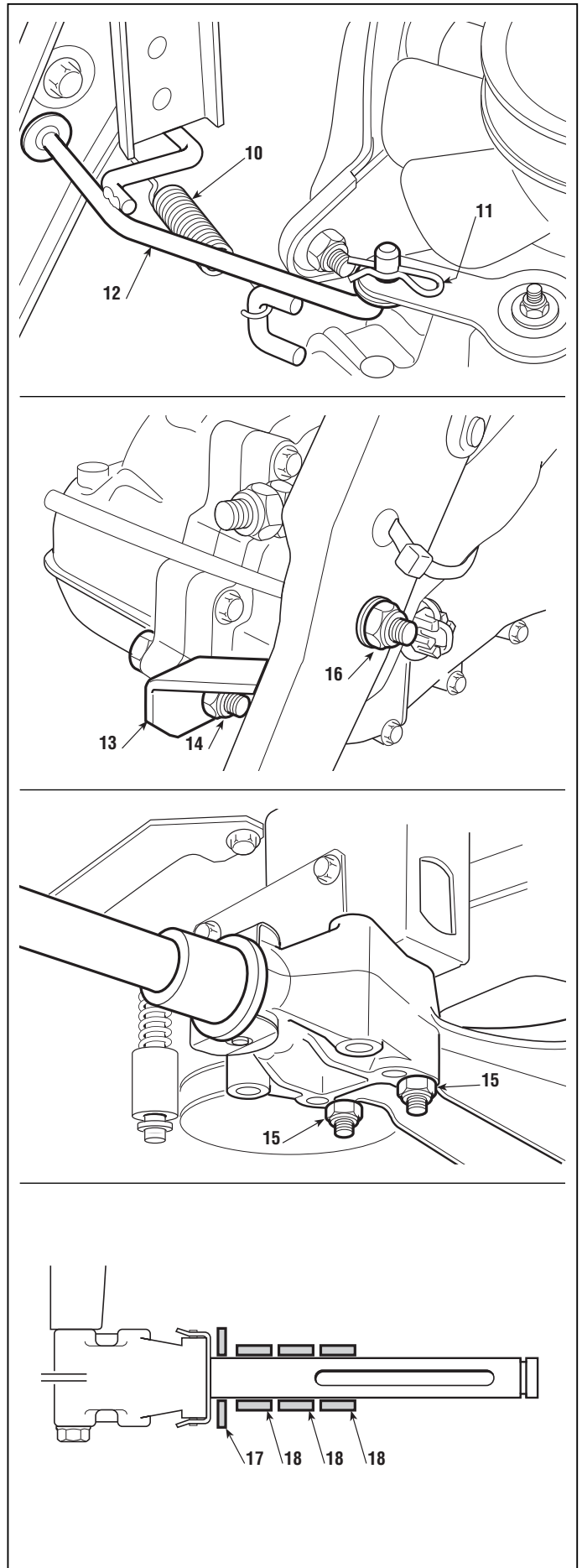

## 5.8.2 REMOVAL OF THE CUTTING DECK

from 2003 to

page 1 / 2

### 5.8 REMOVAL OF THE CUTTING DECK

*Removing the cutting deck facilitates all the overhaul and replacement of hubs, bearings and blade shafts.*

*With some practice and experience it is possible to do this work with the deck still in position.*

Pull out the external split pin (1) through the inspection hole in front of the seat and remove the pin (2) from the inside, in order to disconnect the collector channel (3).

Bring the cutting deck to position «1» and put a 40 mm block underneath the rear right wheel.

Pull out the split pin (4) in order to disconnect the entire bracket (5) from the blade engagement lever (6).

► **in GGP engine models:** release the adjuster (18) (without loosening the nuts) and the safety cable spring (19).

► **in mechanical drive models:** slide the two belt shifter bushes (7) up until the belt (8) is released from the engine shaft pulley (9).

► **in hidrostatic drive models:**  
 ► Dismantle the engine pulley [see 5.6] to release the belt.

Unscrew the nut (10) in order to pull the pin (11) out of the front left lifting lever (12).

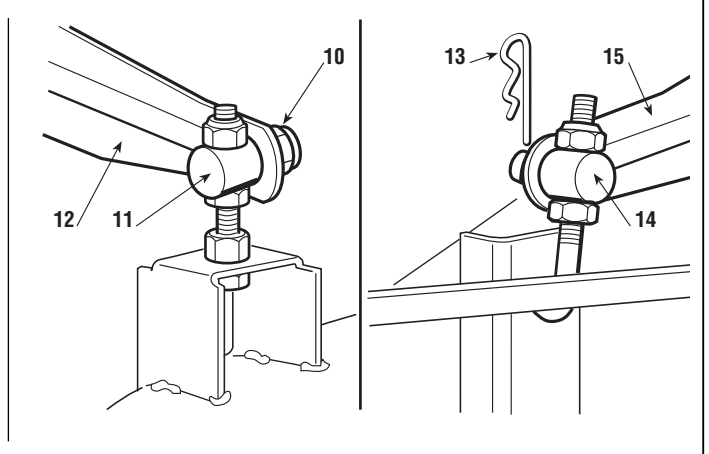
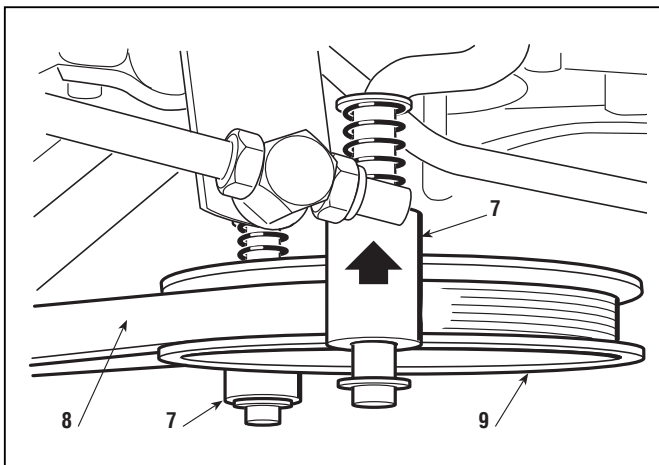
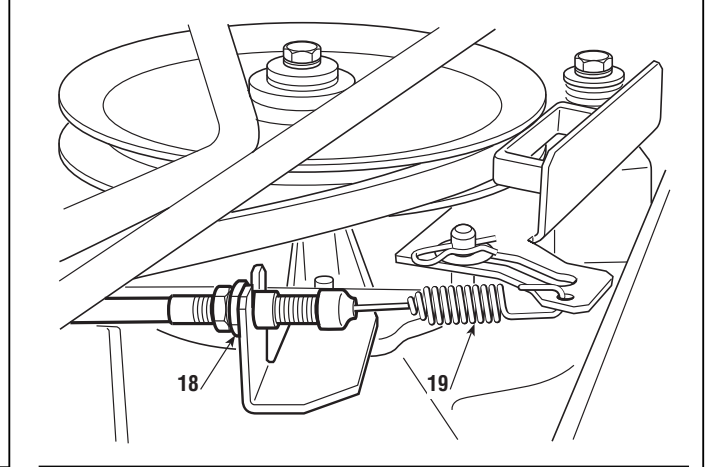
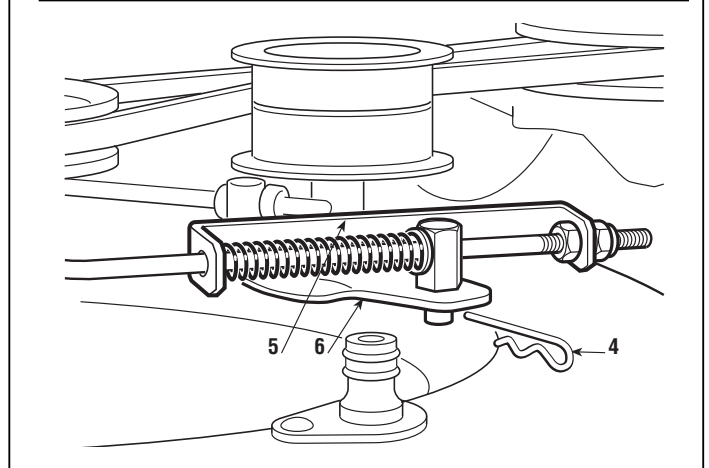
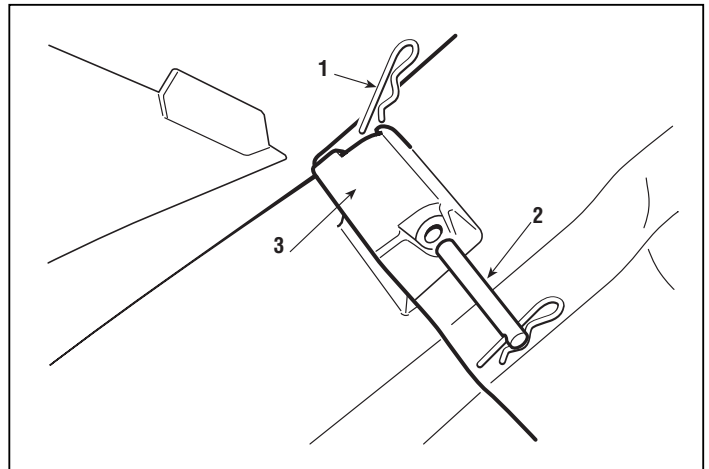

## 5.8.2 REMOVAL OF THE CUTTING DECK

from 2003 to

page 2 / 2

Pull the elastic split pin **(13)** of the pin **(14)** in the rear right lever **(15)** and the elastic split pin **(16)** fastening the pin to the front right lever **(17)**.

Take care not to touch the nuts and lock-nuts so that they remain aligned for assembly  
After checking that there is nothing in the way, the deck can be removed, first by rotating it slightly to the left so that all the pins come out of their housings. Then take it out from the right-hand side.

On assembly, first remove the block underneath the rear right wheel.

Check that the pin **(11)** moves freely [see 2.6 B].

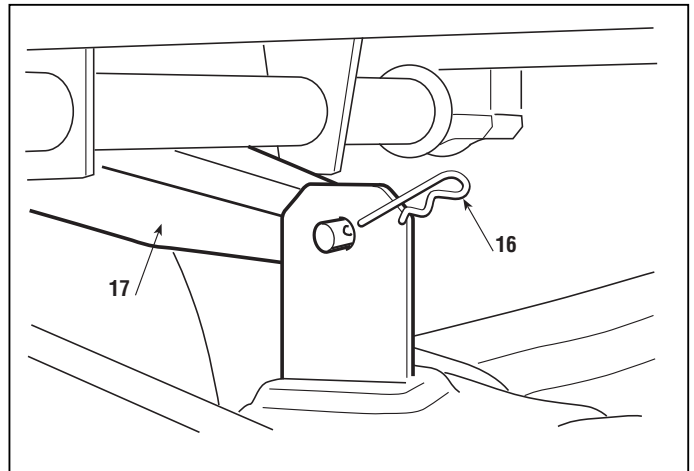

## 6.1.2 REPLACEMENT OF TYRES AND WHEELS

from 1998 to

page 1 / 1

### 6.1 REPLACEMENT OF TYRES AND WHEELS

#### A) Tyres

Tyres used can be:

- "Tubeless" type,
- with air chamber,

and so every repair of a hole in the tyre must be done by a tyre specialist according to the methods used for each type of tyre.

After replacing one or more tyres or the wheels, it is always necessary to check the pressure and to check the alignment of the cutting deck [see 4.6].



#### WARNING

Replace distorted wheel rims as they could impair the tyre's hold.

#### B) Wheels

The wheels are held by a snap ring (1) which can be removed with the help of a screwdriver.

#### NOTE

If a wheel is jammed onto the shaft, use a releasing spray directed around the splining hole.

On assembly it is advisable to spread grease on the shaft to facilitate the next wheel removal.

**For the front wheels:** replace the shoulder washer (2) and the flexible ring (1) with the bevel facing inwards.

#### NOTE

For tyres with air chamber, install a spacer (4) inside.

**For the rear wheels:** replace the shoulder washer (2) and the flexible ring (1) with the bevel facing inwards and check the axial gap of the wheel on the shaft; if it is greater than 3 mm, a spacer (3) must be fitted between the wheel hub and the shoulder washer (2).

#### Tyre pressures

Front .....	1.5 Bar
Rear .....	1.0 Bar

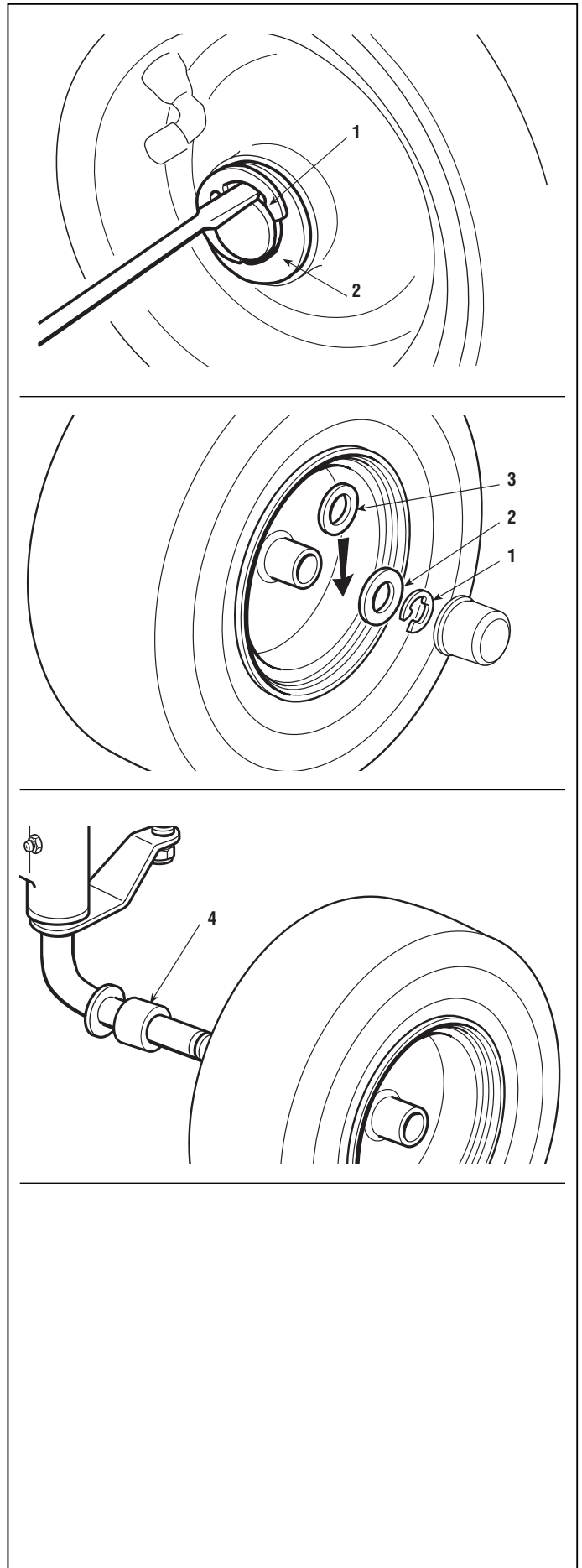

## 6.2.0 REPLACEMENT OF FRONT WHEEL BEARINGS

from 1998 to

page 1 / 1

### 6.2 REPLACEMENT OF FRONT WHEEL BEARINGS

➡ Dismantle the front wheel [see 6.1].

The front wheel bearings **(1)** are force splined into the front wheel hub.

To be able to remove a bearing, a 10 - 12 mm. round bar **(2)** is needed. Insert this from the opposite side and hammer it on various points around the internal circumference of the bearing.

The new bearing must be inserted with the help of a plastic mallet and a bronze pad **(3)** **working only on the outer ring of the bearing.**

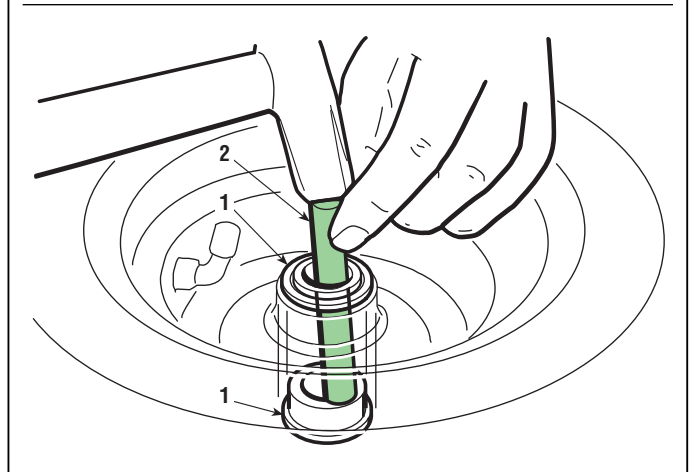
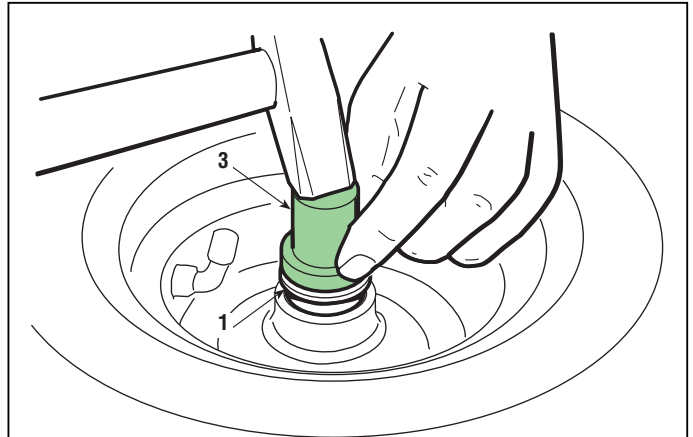

6.3.0	from 1998 to
<b>REPLACEMENT OF THE STEERING COMPONENTS</b>	page 1 / 1

## 6.3 REPLACEMENT OF THE STEERING COMPONENTS

### A) Dismantling the pinion and the ring gear

➡ Follow the same procedure as that for adjusting free play [see 4.7].

### B) Dismantling the steering shaft

After having dismantled the pinion and the ring gear as described at point "A", take out the snap ring (1) from its seat in the shaft (2) and extract the shaft from the bushings (3) pulling it downwards.

After having refitted all the components it will be necessary to ...

➡ Adjust the free play between the pinion and the ring gear [see 4.7], remembering that with a new pinion and ring gear it is not necessary to insert spacers in-side the hub.

➡ Check the toe-in and the alignment of the steering wheel [see 4.8].

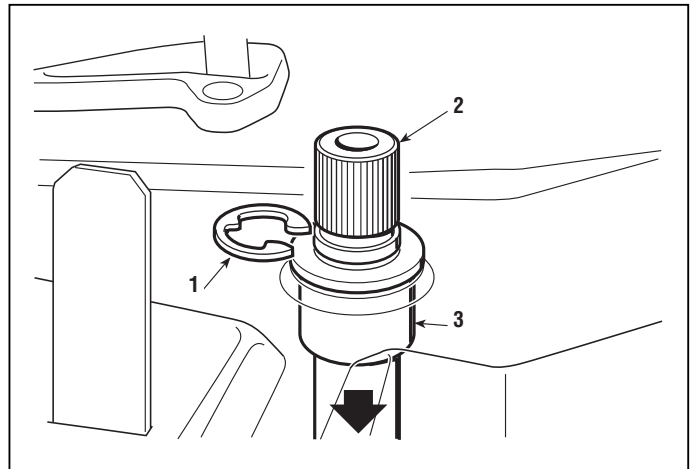



## 6.4.0 REPLACEMENT OF THE DRIVE BELT

from 1998 to

page 1 / 1

### 6.4 REPLACEMENT OF THE DRIVE BELT

- Dismantle the engine pulley [see 5.6] to release the belt.
- Lift the wheels cover [see 2.5].

It also helps if the transmission belt is loosened.

This is done by ...

➤ **in mechanical drive models:** engaging the parking brake

➤ **in hydrostatic drive models:** releasing the spring (1) of the stretcher

Dismantle the pulley of the stretcher (2), held by the nut (3).

➤ **mechanical drive models:**  
Remove the snap ring (4) and lift the pulley (5) just enough to free the belt (6).

At this point the belt can be removed.

On reassembling, make sure that the belt (6) is correctly positioned in the pulleys inside the rims.

When assembly is completed ...

- Close the wheels cover [see 2.5].
- Refit the engine pulley [see 5.6].

➤ **mechanical drive models:**  
➤ Adjust the drive engagement [see 4.5].

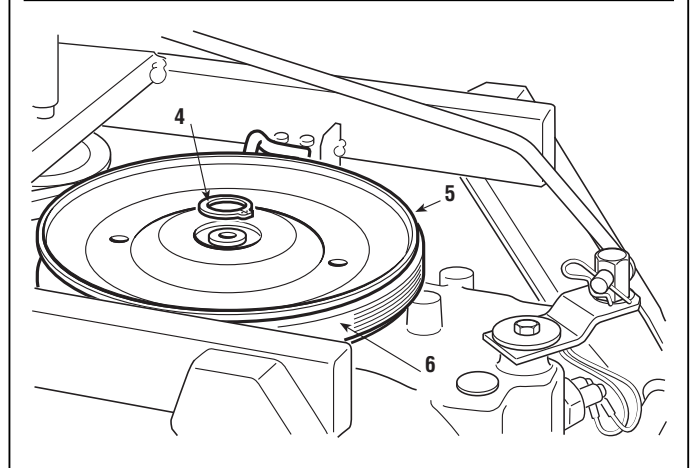
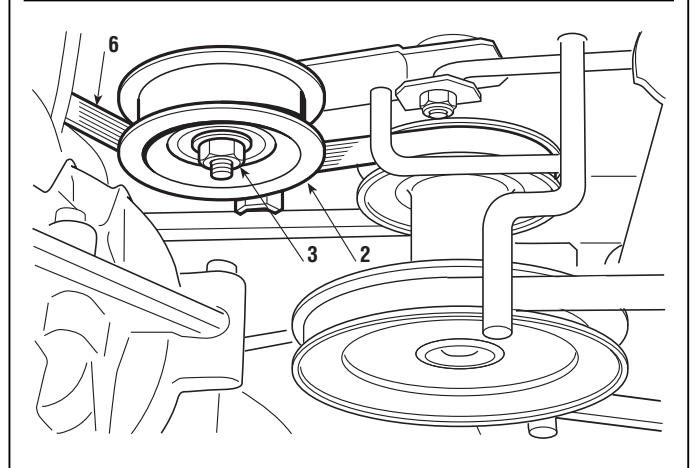
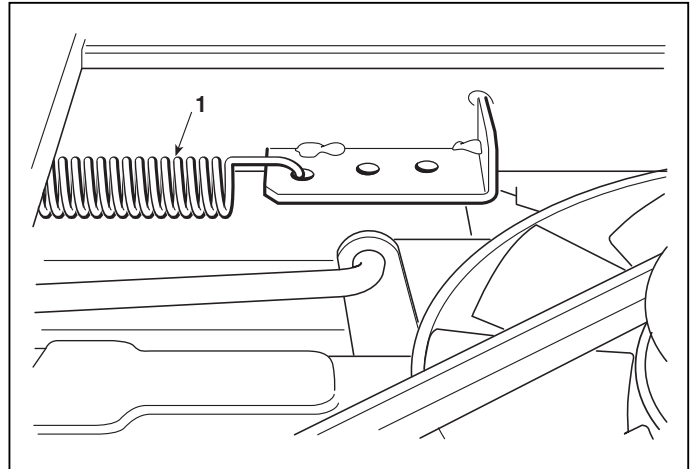

### Tightening torque

3 Pulley fixing nut ..... 25 ÷ 30 Nm

## 6.5.2 REPLACEMENT OF THE BLADE BELT

from 2003 to

page 1 / 1

### 6.5 REPLACEMENT OF THE BLADE BELT

Bring the cutting deck to position «1» to gain easy access to the upper area.

► **in mechanical drive models:**  
slide the two belt shifter bushes (1) up until the belt (2) is released from the engine shaft pulley (3).

► **in hydrostatic drive models:**  
Dismantle the engine pulley [see 5.6] or pull it out until the belt (2) is released.

Put the blade engagement lever in the engaged position to free the brake (4).

► **in GGP engine models:** release the adjuster (4a) (without loosening the nuts) to free the brake (4).

Loosen the screw (5) in order to move the stretcher pulley (6) until the belt (2) is released, without unscrewing it completely.

Dismantle the pulley (7) of the blade shaft attached by the screw (8).

At this point the belt can be taken out and replaced.

On reassembling, take care to exactly position the new belt in the pulley rims.

When it has been reassembled, it is a good idea to ...

☛ Adjust the blade engagement [see 4.1].

☛ Check that the blade brake is working properly [see 4.2].

### Tightening torques

3	Guide pulley nut .....	25 ÷ 30 Nm
7	Blade pulley screw .....	25 ÷ 30 Nm

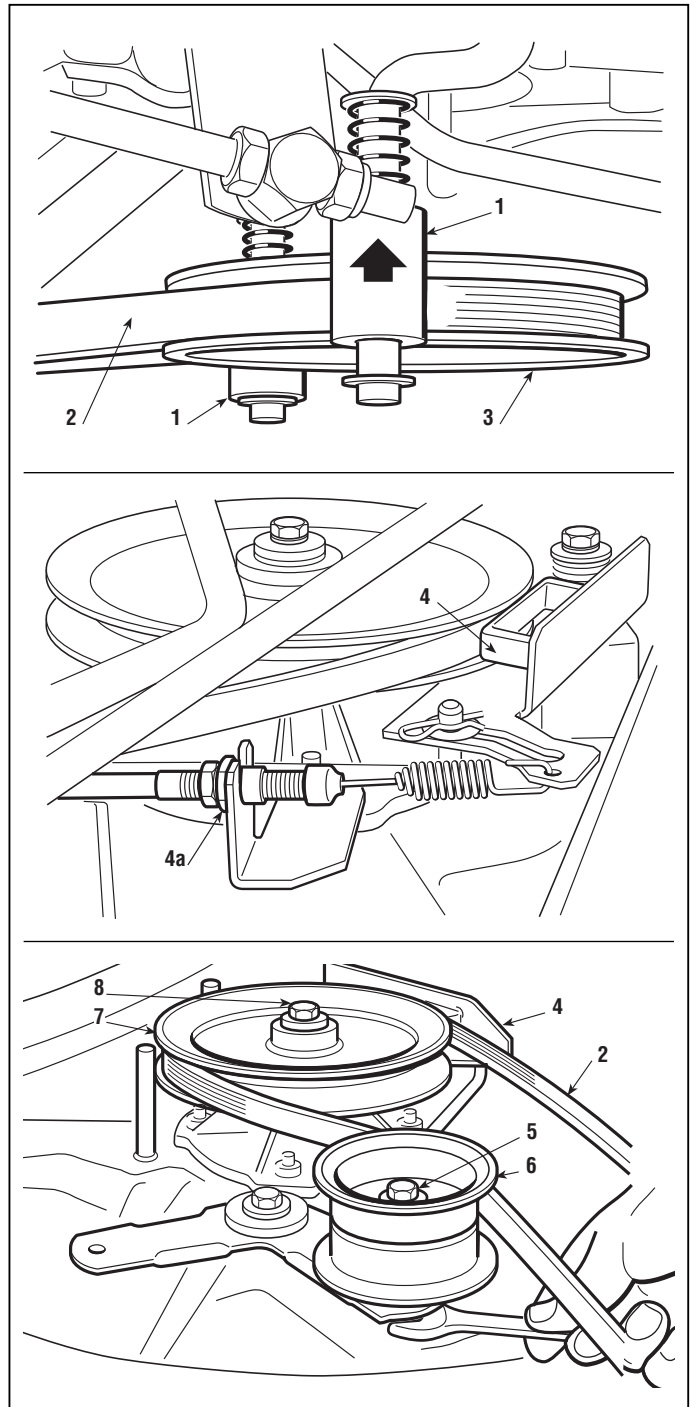

## 6.6.0 - REPLACEMENT OF THE SUPPORT AND SHAFT OF THE BLADE

from 1998 to

page 1 / 2

### 6.6 REPLACEMENT OF THE SUPPORT AND SHAFT OF THE BLADE

➤ Remove the cutting deck [see 5.8].

#### NOTE

This operation is not strictly necessary since, with a little practice and experience, it is possible to dismantle the deck supports without removing the deck. If not removed it would be best to put the deck into a middle position for easy access both above and below.

Put the blade engagement lever into the engaged position to free the brake (1), or manually move the brake (1) away and dismantle the pulley (2) from the blade shaft, attached by the screw (3).

➤ Dismantle the blade [see 4.10] and take out the hub.

Dismantle the flanged support (4) by unscrewing the four fixing screws (5).

**The entire support (4), including shafts and bearings, is a spare part available as single assembly unit.**

If you should want to just replace the shaft or bearings, remove the key (6) and hit the shaft with a plastic mallet on the pulley side in order to remove the shaft together with the lower bearing (7).

After having removed the Sieger ring (8), the dust cover (9) and the key (6), the bearing (7) splined onto the shaft can be removed using a normal extractor, taking care to close up the threaded hole (11) with a screw to prevent the point of the extractor from damaging the thread.

The second bearing still in place must be removed by hitting it from the inside of the flange using a 12 ÷ 15 mm diameter round bar (12).

On reassembling, first put the shaft into the hole of the lower bearing and insert this into the support.

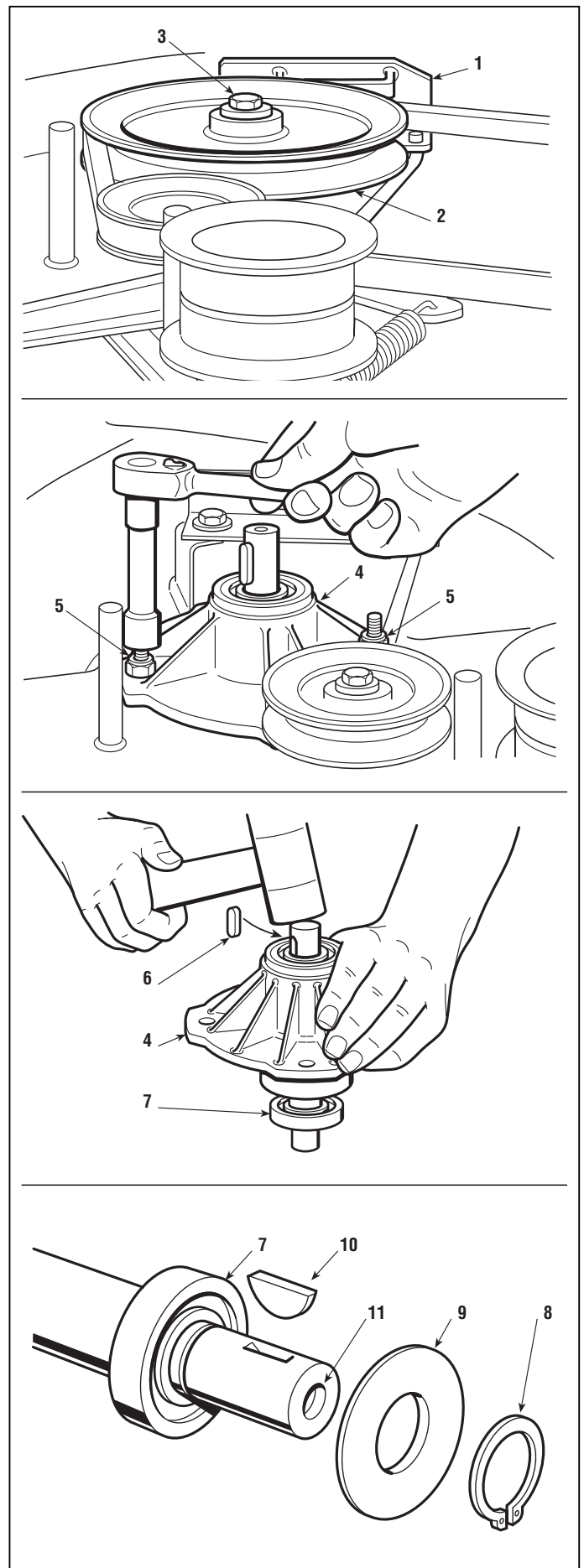

## 6.6.0 - REPLACEMENT OF THE SUPPORT AND SHAFT OF THE BLADE

from 1998 to

page 2 / 2

Fit on the upper bearing and, using the special bush (13) which works on the inner ring, hit it squarely with a mallet until the bearing is fully driven home.

Fit the flange support onto the deck, fully tightening the nuts (5).

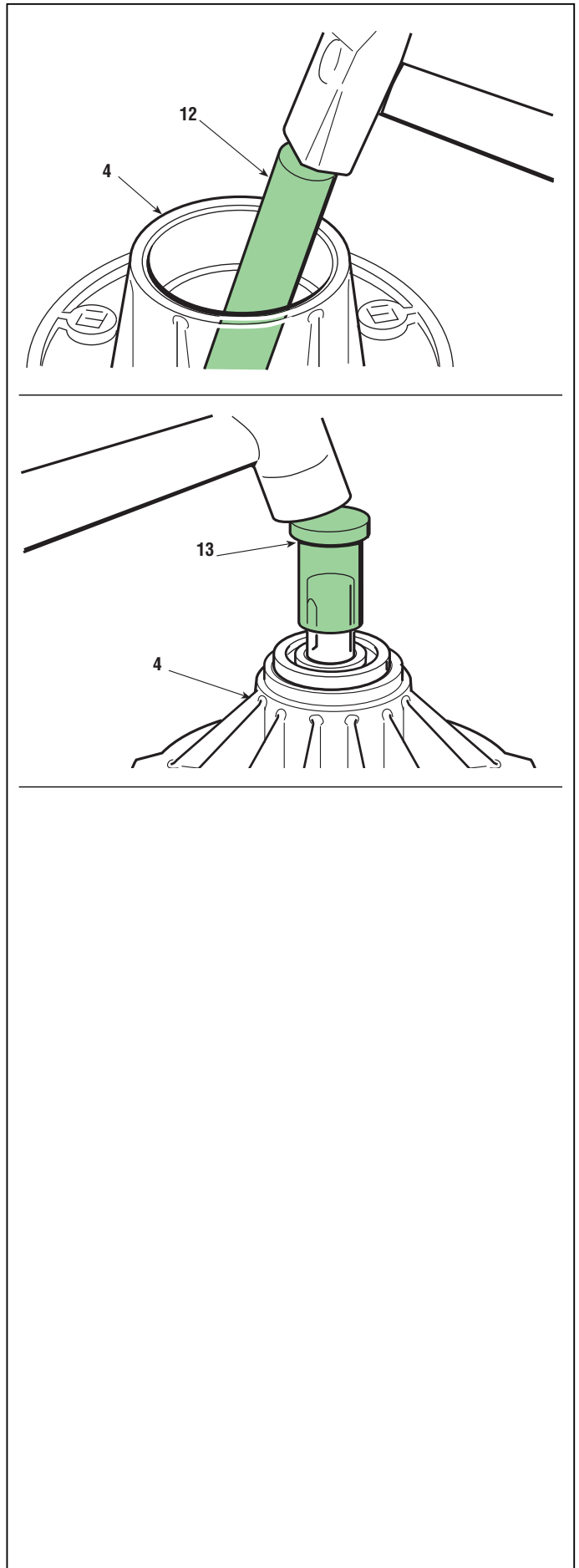

### Tightening torques

3 Blade pulley screw. ....	25 ÷ 30 Nm
5 Nuts for flanged support .....	25 ÷ 30 Nm

## 6.7.0 REPLACEMENT OF THE ACCELERATOR

from 1998 to

page 1 / 1

### 6.7 REPLACEMENT OF THE ACCELERATOR

Take the small knob **(1)** off the accelerator.

☛ Lift the wheels cover [see 2.5].

Disconnect the end of the cable **(2)** from the coupling terminal **(3)** on the engine.

Remove the clamp **(4)**, undo the two screws **(5)** and take out the accelerator together with the cable.

On reassembling, put the accelerator lever in the «MINIMUM» position shown on the label, connect the end of the wire **(2)** to the terminal **(3)** on the engine after having moved the cursor **(6)** in the same «MINIMUM» position specific to each type of engine and shown in the instruction handbook.

Lastly, put back the clamp **(4)** and ...

☛ Close up the wheels cover [see 2.5].

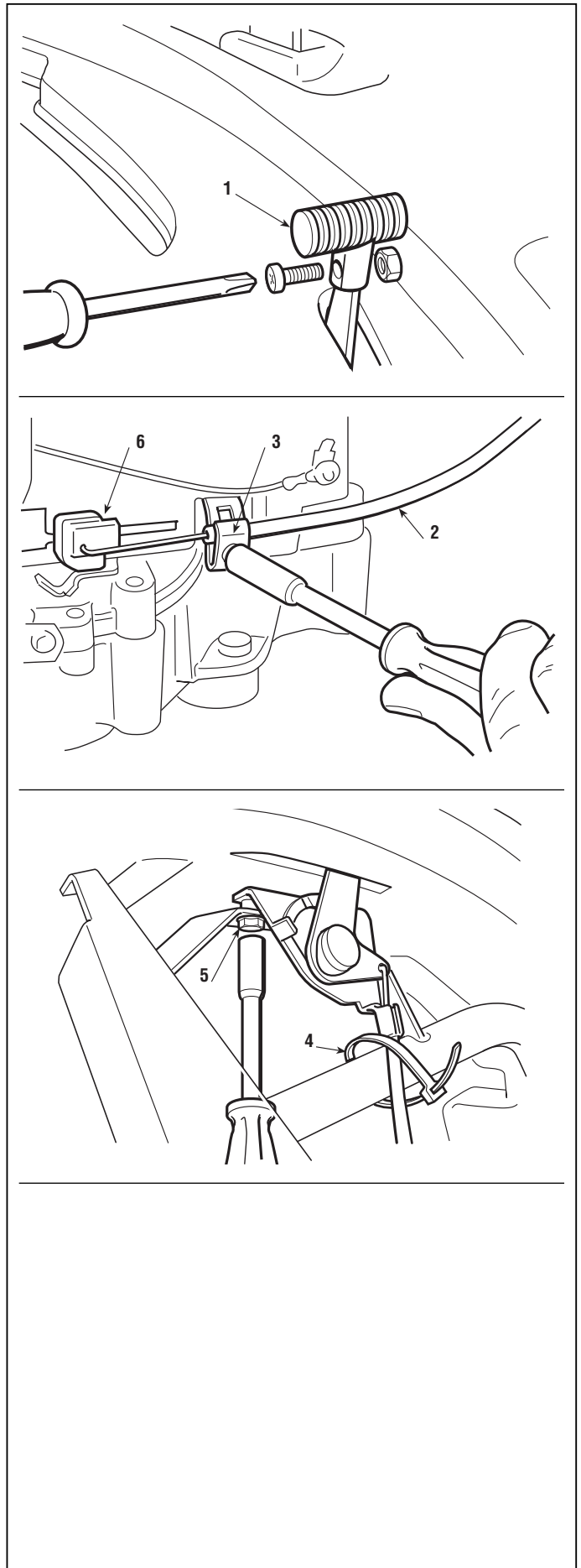

## 6.8.2 REPLACEMENT OF THE BRAKE PADS AND DISC

from 2009 to  
page 1 / 1

### 6.8 REPLACEMENT OF THE BRAKE PADS AND DISC (► *mechanical drive models*)

➡ Remove the left-hand rear wheel [see 6.1].

Dismantle the pin (1) from the lever (2) and undo the two screws (3) which hold on the support (4).

The support (4) contains a pad (5a) separated from the control pistons (6) by a plate (7). The other pad (5b) can be reached by taking off the disc (8).

If there is oil on the pads, clean with solvent and go over them with fine-grade abrasive paper.



Both pads should be replaced if the depth of either of them is less than 5 mm.



Renew the disc if it is damaged, distorted or less than 4 mm thick.

On reassembling, carefully reposition all the components and refit the complete support.

#### NOTE

During all these operations it is better to not unscrew or loosen the central screw (9) to avoid altering the calibration of the cam driving the pistons.

If it has been moved, the lever's free movement will have to be checked [see 4.3].

When fully reassembled ...

➡ Check the brake adjustment [see 4.3].

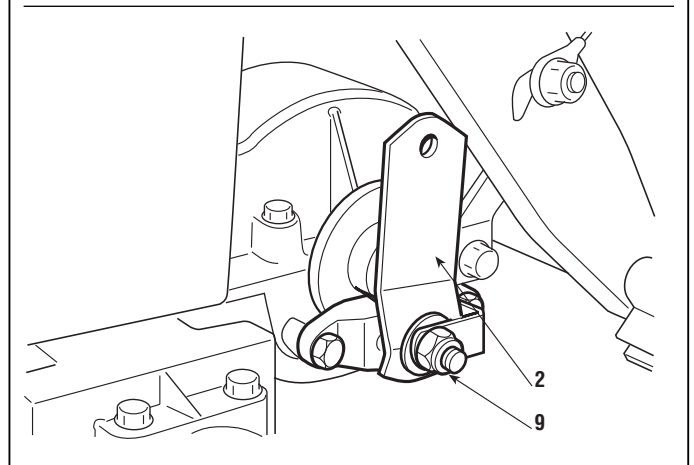
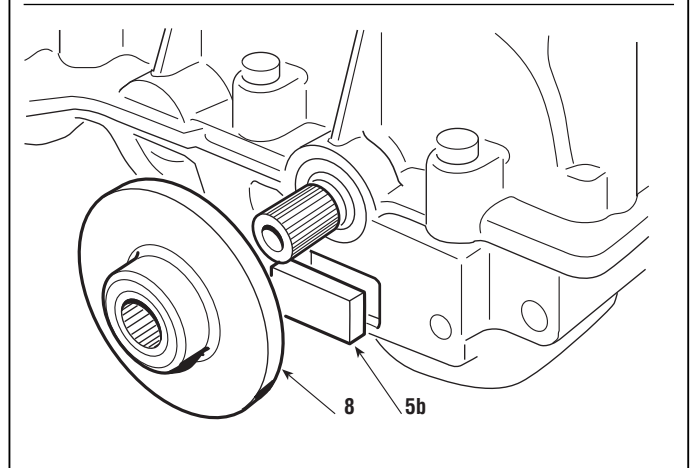
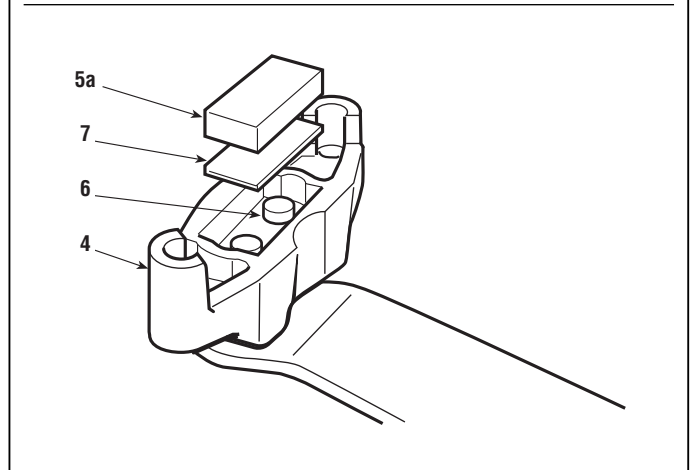
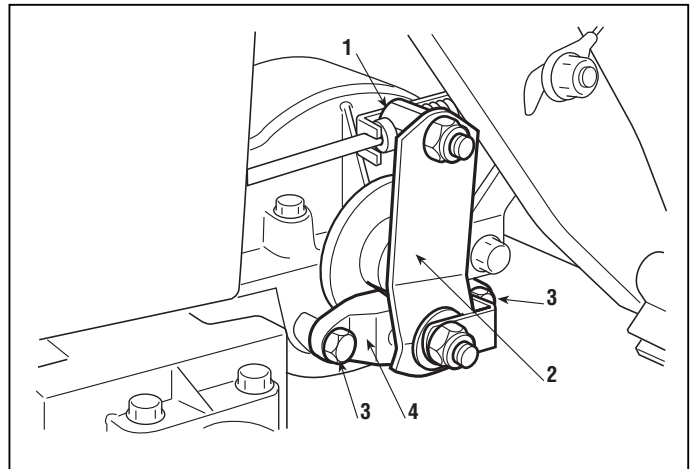

## 6.9.1 REPLACEMENT OF THE DRIVE LEVER UNIT

from 2004 to

page 1 / 2

### 6.9 REPLACEMENT OF THE DRIVE LEVER UNIT ( ► *hydrostatic drive models* )

- Lift up the wheels cover [see 2.5].
- Remove the collector channel [see 5.5]

With the pedal released, detach the rod **(1)** connecting to the rear axle by unscrewing the nut of the pin **(2)**, and the rod **(3)** connecting to the pedal by unscrewing the nut of the pin **(4)**.

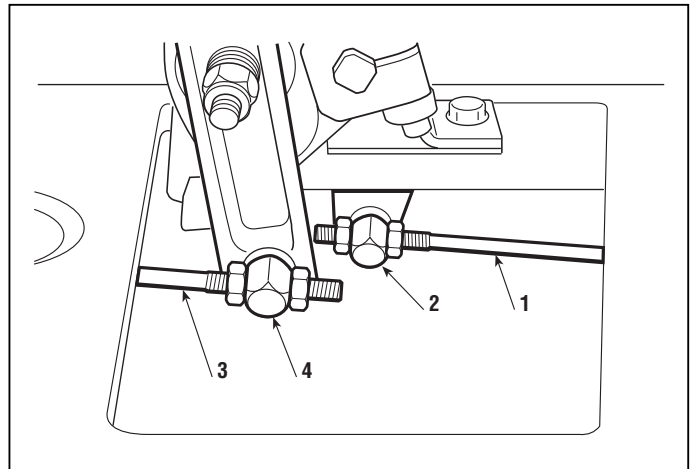

Unhook the barrel **(5)** and detach the return cable **(6)**.

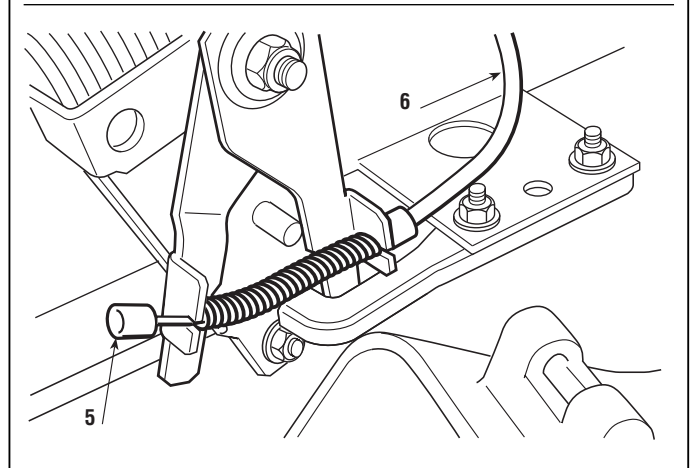

Unscrew the two screws **(11)** and remove the support **(10)** with the whole lever unit.

The whole unit is available as a spare part in a single assembly unit.

Fit the new unit keeping it to the right, fixing it using the two screws **(11)**.

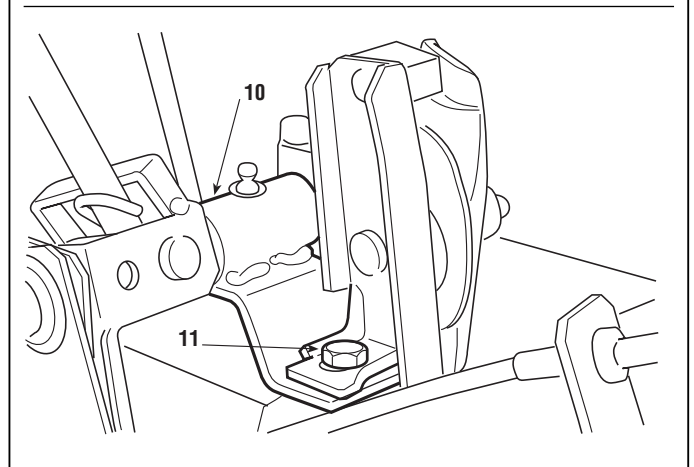

Hook the barrel **(5)** of the cable **(6)** and refit the pins **(2)** and **(4)** without fully tightening their nuts, and after having loosened the adjuster nuts of the rods **(1)** and **(3)**.

Check that the end **(12)** of the hook is positioned in a way that does not impede the lever's **(13)** travel and that it stops the movement of the lever **(14)**.

If necessary, only loosen the back screw **(15)** and move the terminal **(12)** just enough to achieve the condition described above.

If you accidentally loosen both screws **(15)** and **(16)**, thus losing their original position, you need to ....

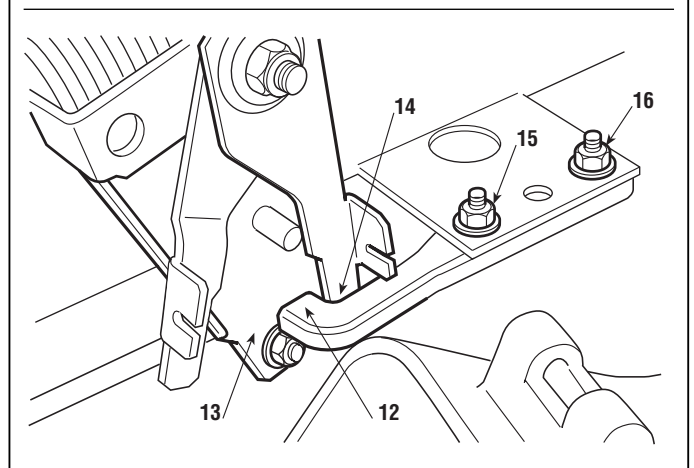

- Adjust the stop [see 4.5.E].

 	<b>6.9.1</b> <b>REPLACEMENT OF THE DRIVE LEVER UNIT</b>	 	from 2004 to page  2 / 2
--	--	--	--

When this has been done ....

- Find the lever's "neutral" position [see 4.5.A].
- Adjust the release rod for the clutch device [see 4.5.B].
- Adjust the lever's return cable [see 4.5.D].

and, lastly ...

- Refit the collector channel [see 5.5].
- Close up the wheels cover [see 2.5].

### Tightening torques

---

**11** Drive lever support screws ..... 25 ÷ 30 Nm

---



## 6.10.0 REPLACEMENT OF THE LEVER RETURN CABLE

from 1998 to

page 1 / 1

### 6.10 REPLACEMENT OF THE LEVER RETURN CABLE ( ➤ *hydrostatic drive models*)

- Lift the wheels cover [see 2.5].
- Remove the collector channel [see 5.5]

With the pedal released, unhook the barrel (1) from the lever (2), take it off the lever (3), loosen the nut (4) of the adjuster, release the spring (5) and remove the cable (6).

Start fitting the spring (5) using the upper hole of the lever (7) and then completing the operations described before in reverse order.

When fitting is completed,

- Adjust the cable [see 4.5.D].
- Refit the collector channel [see 5.5].
- Close up the wheels cover [see 2.5].

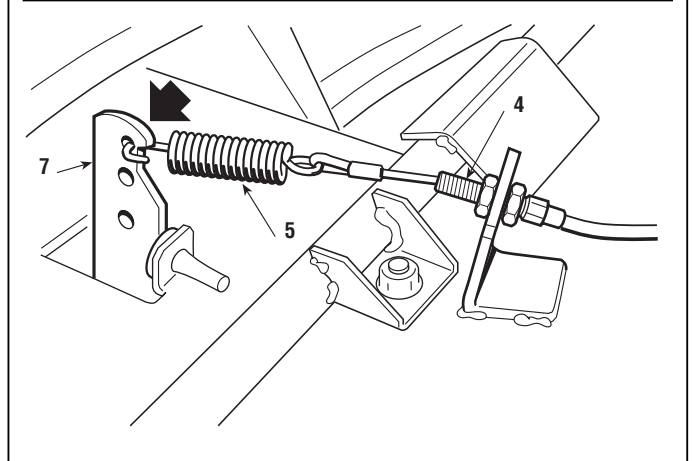
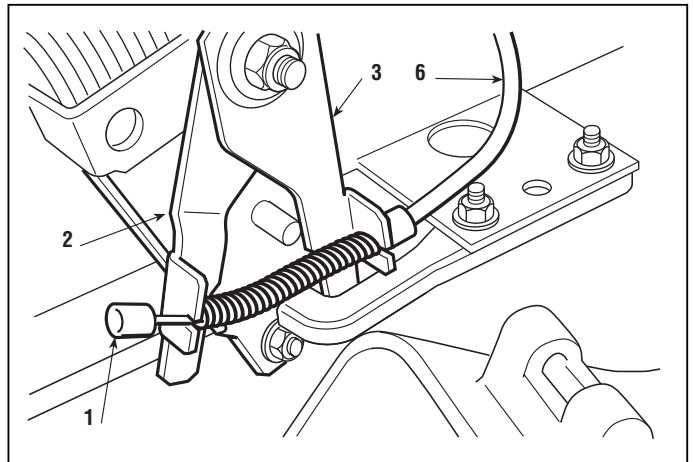

## 6.11.0 - REPLACEMENT OF THE FRICTION DISCS FOR CLUTCH DEVICE

from 1998 to

page 1 / 1

### 6.11 REPLACEMENT OF THE FRICTION DISCS FOR CLUTCH DEVICE

( ► hydrostatic drive models)

The friction discs can lose efficiency if they get dirty with oil or grease, or if they are accidentally lubricated by the user, in which case they must be replaced.

➡ Lift the wheels cover [see 2.5].

Unscrew the nut (1) and dismantle the pin (2) from the lever (3). By unscrewing the nut (4), you can take out the spring (5) and the lever (3).

Loosen the nut (6) so that the sector (7) can slide along and be taken off the square shaft (8) together with the two friction discs (9) and the two steel discs (10).

When reassembling, carry out the operations described above in reverse order, making sure that the two tabs of the steel discs are correctly positioned in the recesses made in the lever (3) and on the support bracket (11), and ensuring that the sector (7) is pushed down on the shaft (8) until the recommended distance of 57 - 57.5 mm is achieved.

When fully assembled ...

➡ Adjust the release rod [see 4.5.B].

➡ Adjust the spring [see 4.5.C].

➡ Close up the wheels cover [see 2.5].

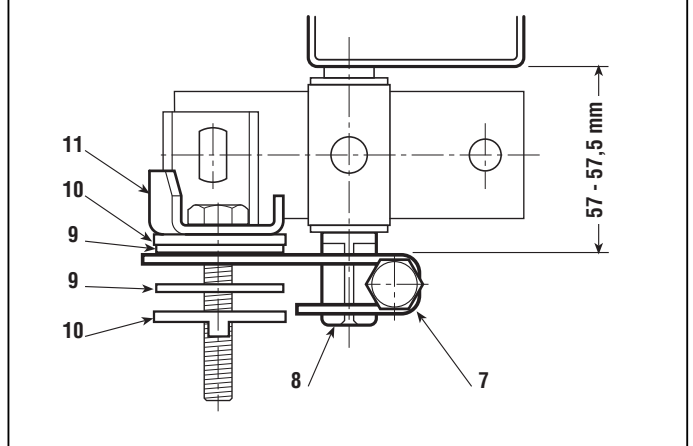
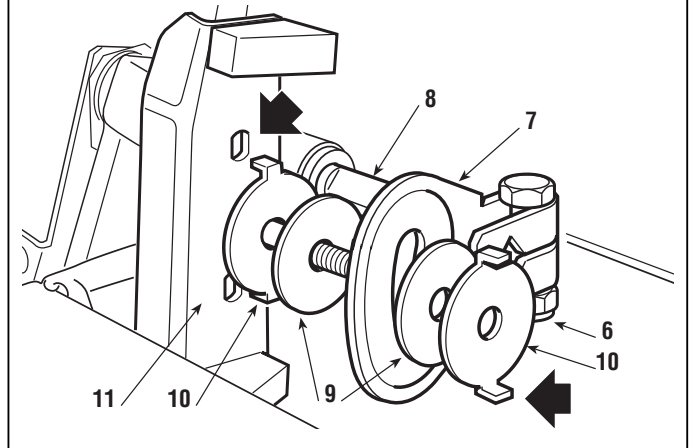
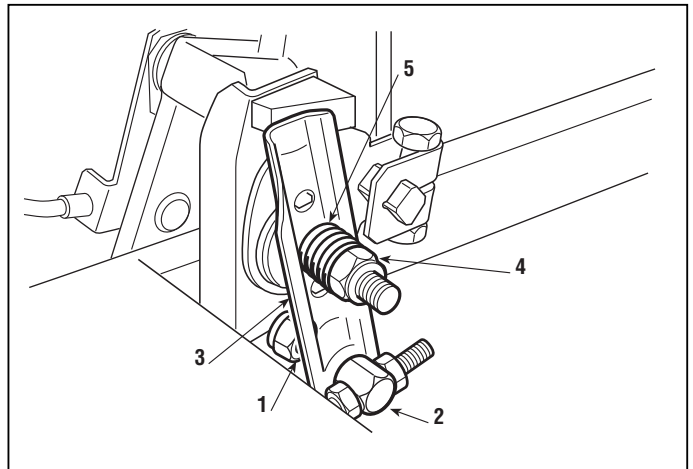

### Tightening torque

6 Drive lever sector nut ..... 10 ÷ 15 Nm

## 6.12.1 REPLACEMENT OF THE SEAT'S SAFETY CABLE

from 2009 to

page 1 / 1

### 6.12 REPLACEMENT OF THE SEAT'S SAFETY CABLE (► in GGP and Honda GXV390 engine models)

- ➡ Lift the wheels cover [see 2.5].
- ➡ Remove the collector channel [see 5.5].

Release the adjuster **(1)** of the cable **(2)** and the spring **(3)**.

Remove the clamp **(4)** behind the rear left wheel.

Using a screwdriver, remove the cover **(5)** of the right seat spring and push the cable **(2)** up slightly in order to pull out the split washer **(6)** which locks the cable barrel **(7)** in place.

You can now remove the cable **(2)** by pulling out from below.

On assembly, follow the steps described in reverse remembering to:

- put the washer **(6)** back in place underneath the barrel **(7)**.
- carefully put the cap **(5)** back in place. If it is damaged, replace it to prevent water and dust from getting inside, as this would stop the safety cable from working properly.
- pass the cable **(2)** under the guiding jumper next to the pulley **(8)**;
- remount the clamp **(4)** making sure that the cable **(2)** passes over the accelerator cable **(9)** and is well taut between the seat spring and the clamp (with the wheel cover raised).

After attaching the adjuster **(1)** and the spring **(3)**, regulate the adjuster **(1)** until the spring **(3)** is 48 - 49 mm long with the blade disengaged.

- ➡ Reattach the collector channel [see 5.5].
- ➡ Close up the wheels cover [see 2.5].

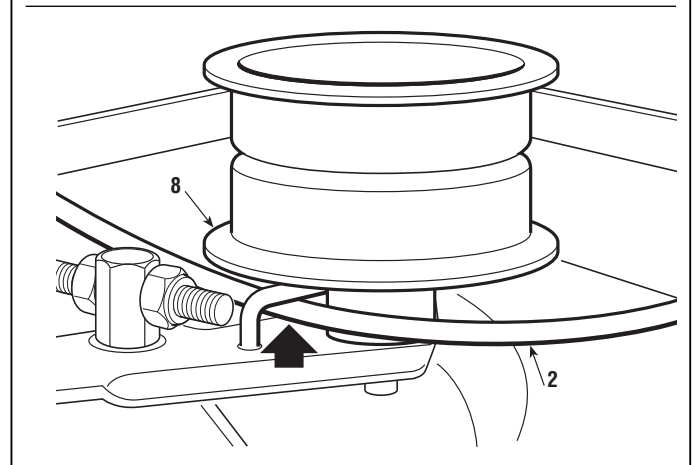
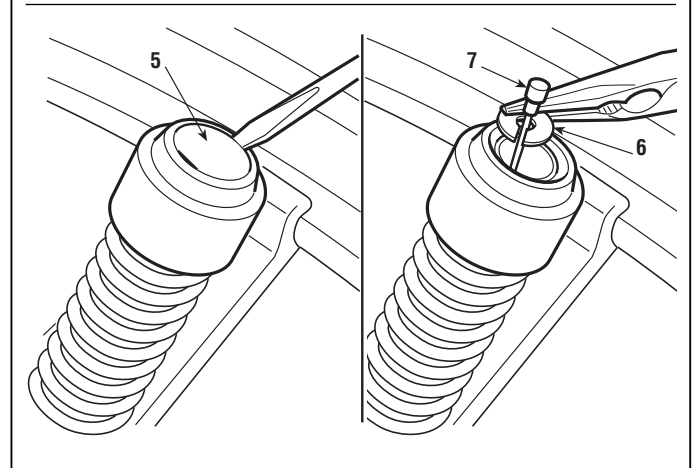
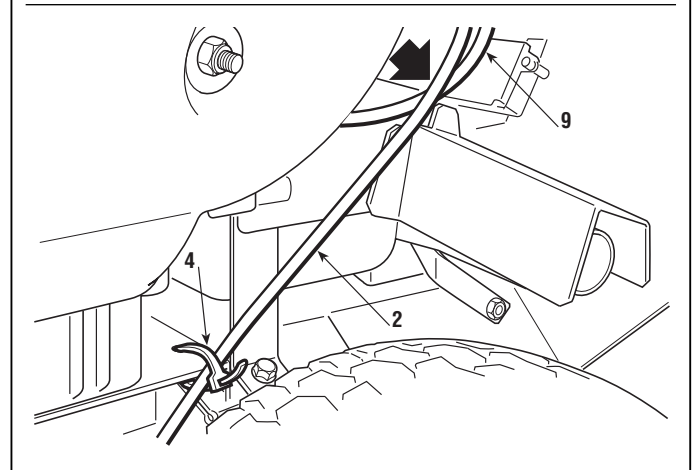
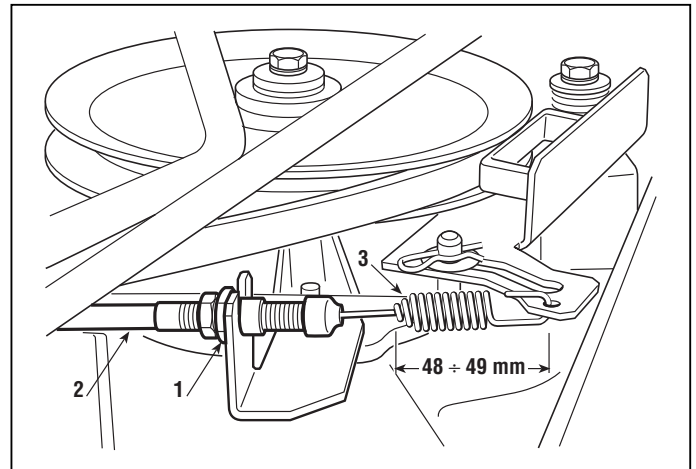

## 7.1.3 - GUIDE TO THE IDENTIFICATION OF PROBLEMS IN THE ELECTRICAL SYSTEM

from 2008 to

page 1 / 3

### 7.1 GUIDE TO THE IDENTIFICATION OF PROBLEMS IN THE ELECTRICAL SYSTEM

Some of the problems connected to the malfunctioning of the electrical system are shown in the following table, with their probable causes and the remedial action to be taken. Should the problem continue after the appropriate checks, seek assistance from your local Service Centre.

**Faulty electronic cards must always be replaced without trying to repair them or replace single components.**

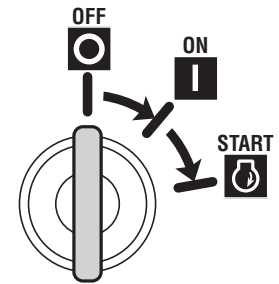

PROBLEM	CAUSE	REMEDY
<b>1. Activation of the self-resetting protection 1) ....</b>		
<b>a) .... on inserting the key in position «ON»:</b>	Battery terminal crossed	Check the battery connections
	Short circuit to earth	Check the connectors and wiring of the microswitches
<b>b) ... in position «START» or after a few seconds' use:</b>	Sulphated battery (it no longer accepts recharging)	Replace the battery
	Faulty or wet electronic card	Check and dry with low pressure tepid air (hair-dryer)
	Disconnected or missing battery	Reconnect the battery, which must always be connected
	Battery terminals corroded or with poor contact	Check and clean the connections
<b>c) ... after several minutes' use:</b>	Poor or missing earth contact on the charge regulator	Check the earth connections and the screws fastening the regulator
	Overvoltage from a malfunction in the regulator	Check the recharge circuit [see 7.7]
	Battery disconnected or faulty during use	Check the battery or wiring
<b>2. With the key in the «ON» position the pilot lamp remains off</b>	The battery is not supplying the card	Check the connection cables Check the battery's condition [see 7.8]
	Battery or card not earthed to frame	Check and put right
	10 A fuse blown	Replace fuse (10 A)
	Battery terminal crossed	Check connections. <b>WARNING!</b> In this case, the card is irreparably damaged and you need to replace it since it is no longer usable!
<b>3. The pilot lamp comes on but, with the key in the «START» position, the starter motor does not turn or lacks power (poor starting)</b>	The battery is not supplying sufficient current	Recharge the battery [see 7.8]
	Badly earthed battery, or the starter relay or motor not earthed	Check and put right
	Defect in the starter relay or carburettor solenoid valve (if applicable)	Make sure the starter relay and carburettor solenoid valve (if applicable) are activated [see 7.5]

1) Activation of the self-resetting protection of the electronic card is signalled by the failure of the LED to light, by it switching off during work, by the engine running erratically or stopping.

## 7.1.3 - GUIDE TO THE IDENTIFICATION OF PROBLEMS IN THE ELECTRICAL SYSTEM

from 2008 to

page 2 / 3

PROBLEM	CAUSE	REMEDY
4. The pilot lamp is flashing with the key in the «START» position and the starter motor does not turn	Starting not permitted [see summary logic table 7.2]	After checking that the conditions are met, check all the microswitches [see 7.3] and the relative wiring
	Malfunction in the electronic card	Try replacing the card with one that is known to work
5. The starter motor turns but the engine does not start	No fuel flow	Check the stop cock and the fuel filter
	Impaired starter system	Check that spark plug caps are positioned correctly Check that the spark plug electrodes are clean and have the correct gap
6. The starter motor continues to turn after engine has started, and does not stop when the key is removed	Mechanical difficulties in the return of the contact breakers of the starter relay	Replace the starter relay.
	Starter works erratically for mechanical or electrical reasons taking excessive current and causing binding of relay contacts	Check the starter motor
7. The starter motor operates as soon as the key is in the «ON» position, and can be turned off only by removing the key (pilot lamp on)	Fault in the card	Replace the card
	Starter block operating faults	Replace the block
8. The pilot lamp does not come on when the key is in the «ON» position but the machine works	Fault in the electronic circuit or in the LED	Replace the card ( <b>NOTE:</b> You can finish the work in any case, but you need to replace the card or signalling LED as soon as possible)
9. The pilot light goes out after several hours' work	Insufficient charge	Check that the charging cable has not detached
		Check that there are no current leakages caused by cables with damaged insulation
		Check that the regulator is working properly [see 7.7]
Charger fuse blown	Replace fuse (25 A) and check the recharge circuit [see 7.7]	
10. The engine stops while in use for reasons not due to the safety devices cutting in continued	The safety devices have cut in or are faulty	Check the microswitch's operation and the relevant wiring [see 7.3 and 7.6]
	Accidental detaching of an electrical wire	Check all wiring
	Starting of engine not permitted [see summary logic table 7.2]	After checking that the conditions are met, check all the microswitches [see 7.3] and the relative wiring

## 7.1.3 - GUIDE TO THE IDENTIFICATION OF PROBLEMS IN THE ELECTRICAL SYSTEM

from 2008 to

page 3 / 3

PROBLEM	CAUSE	REMEDY
<b>11. The 10 A fuse blows</b>	Short circuit or overload on the power side of the electronic card (start-up unit, starter relay) and recharger connector	Find and replace the defective user [see 7.4 and 7.5]
	Short circuit or damage to the electronic card protection (power side)	Try changing the card with one that is known to work. If the problem stops, replace the faulty card
<b>12. The 25 A fuse blows</b>	Faults in the battery charging circuit	Replace fuse (25 A) and check the recharge circuit [see 7.7]
<b>13. No audible signal for the "grass-catcher full" condition</b>	Malfunctioning or faulty blade microswitches and grass-catcher signalling	Check the microswitches and wiring. <b>WARNING!</b> – Check that the blade microswitch stops the engine or prevents it from being started if the acknowledgement conditions are not met [see 7.2]
	Malfunctioning or faulty electronic card	Try changing the card with one that is known to work. If the problem stops, replace the faulty card

## 7.2.1 - SUMMARY TABLE FOR THE CUTTING IN OF THE SAFETY DEVICES

from 2005 to

page 1 / 1

### 7.2 SUMMARY TABLE FOR THE CUTTING IN OF THE SAFETY DEVICES



This table shows the various situations in which the safety devices intervene.

-/- = Uninfluential

#### A) STARTING («START» position)

OPERATOR	GRASS-CATCHER	BLADE	DRIVE	PARKING	ENGINE	PILOT LAMP
-/-	-/-	-/-	<b>Engaged</b>	-/-	DOES NOT start	Flashing
-/-	-/-	<b>Engaged</b>	-/-	-/-	DOES NOT start	Flashing
<b>Absent</b>	-/-	-/-	-/-	<b>Disengaged</b>	DOES NOT start	Flashing

#### B) WHILE CUTTING

OPERATOR	GRASS-CATCHER	BLADE	DRIVE	PARKING	ENGINE	PILOT LAMP
<b>Absent</b>	-/-	-/-	<b>Engaged</b>	-/-	Stops	ON
<b>Absent</b>	-/-	<b>Engaged</b>	-/-	-/-	Stops	ON
-/-	<b>Missing</b>	<b>Engaged</b>	-/-	-/-	Stops	ON
-/-	-/-	<b>Engaged</b>	-/-	<b>Engaged</b>	Stops	ON
<b>Absente</b>	-/-	-/-	-/-	<b>Disengaged</b>	Stops	ON

## 7.3.2 - SAFETY MICROSWITCHES OPERATION CHECK AND SWITCHES

from 2006 to

page 1 / 1

### 7.3 SAFETY MICROSWITCHES OPERATION CHECK AND SWITCHES

This check is made by detaching all the connectors and by using the tester in the Ohm-meter function. This operation should be done, without the driver on board, by making contact with the ferrules on the contacts of the female connector of the wiring (1) and should give this result:

N° Contacts	Tester reading and condition		
<b>GRASS-CATCHER ATTACHED MICROSWITCH</b>			
3 - 6 (CN2)	∞ (without g.catc.)	O (with g.catcher)	
<b>SEAT MICROSWITCH</b>			
3 - 5 (CN2)	∞ (absent)	O (seated)	
<b>PARKING MICROSWITCH</b>			
3 (CN2) - 1 (CN5)	O (free)	∞ (engaged)	
<b>BLADE MICROSWITCH</b>			
3 - 4 (CN2)	∞ (engaged)	O (disengaged)	
<b>"IN NEUTRAL" SIGNAL</b>			
3 - 1 (CN2)	∞ (drive)	O (neutral)	
<b>GRASS-CATCHER FULL MICROSWITCH</b>			
2 (CN2) - Massa	O (full)	∞ (empty)	
<b>STARTER UNIT</b>			
+ Battery - 2 (CN3)	∞ (OFF)	O (ON)	O (START)
+ Battery - 3 (CN3)	∞ (OFF)	∞ (ON)	O (START)

### ENGINE STOP

This operation must be done by making contact between the ferrules of the electronic card (2), keeping all the connectors attached, and should give this result:

N° Contacts	Tester reading and condition
5 (CN3) - Earth	O (Always)

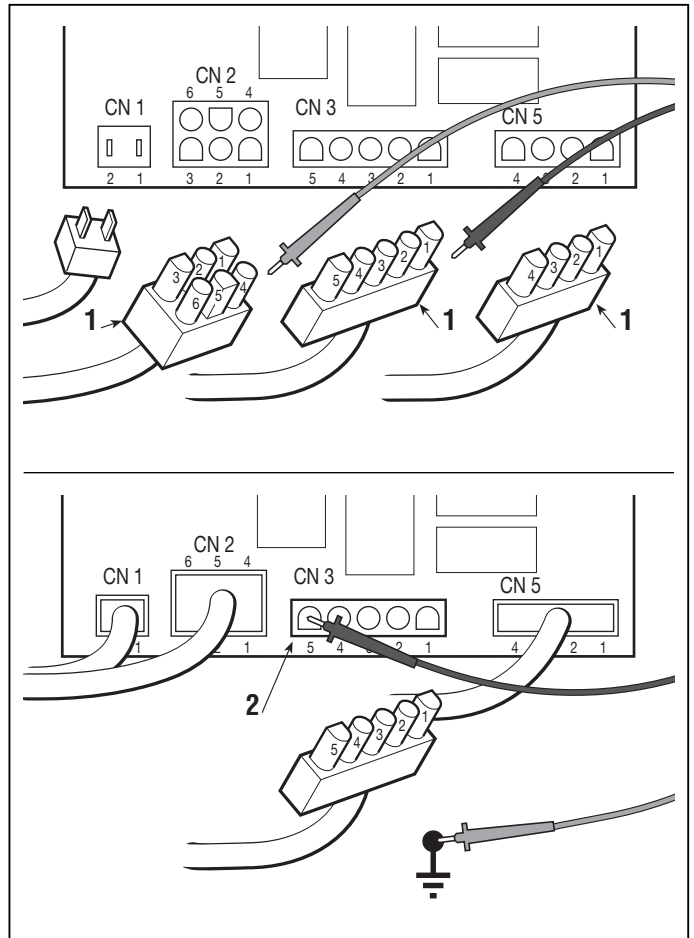



## 7.4.2 TERMINAL BOARD SUPPLY CHECK

from 2006 to

page 1 / 1

### 7.4 TERMINAL BOARD SUPPLY CHECK

This check is done with the tester in voltmeter function (Volt DC 0 ÷ 20), with the black ferrule on terminal 3 (CN5) and the red ferrule on terminal 2 (CN3) of the wiring connectors (1).

– The key in the «ON» position.

The reading shows the battery voltage, which should never go below 11 Volts.

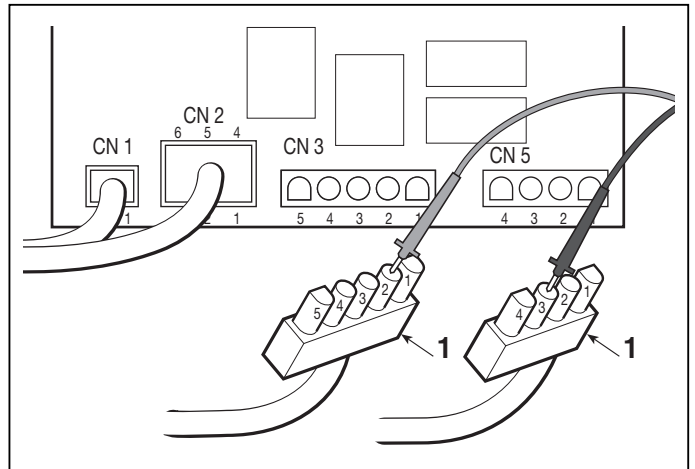

## 7.5.3 - STARTER RELAY AND CARBURETTOR SOLENOID VALVE OPERATION CHECK

from 2008 to

page 1 / 1

### 7.5 STARTER RELAY AND CARBURETTOR SOLENOID VALVE OPERATION CHECK

#### A) Starter relay operation check



**WARNING!** - Remove the cap of the sparking plug, since the safety systems that normally prevent accidental starting of the engine are cut out when the checking procedure is carried out.

To do this requires:

- engaging the parking brake;
- disengaging the blade;
- the key in the «ON» position.

Disconnect the connector CN3.

In making a bridge between the terminals 2 and 4 (CN3) of the wiring connectors **(1)**, the click of the relay bobbin should be heard and the starter motor should come into action.

If the relay clicks but the starter motor does not go, make a bridge **(2)** with a large section cable (5 mm<sup>2</sup>) between the power contacts of the relay.

If the starter motor comes into operation, look for the fault within the relay or replace it. Otherwise, check the starter motor together with its wiring.

#### B) Carburettor solenoid valve operation check (where fitted)

All the connectors must be connected to make this check. **(3)**.

When the key is set to «ON», a click must be heard from the carburettor solenoid valve coil.

Otherwise, check wiring and, if the problem persists, replace the solenoid valve.

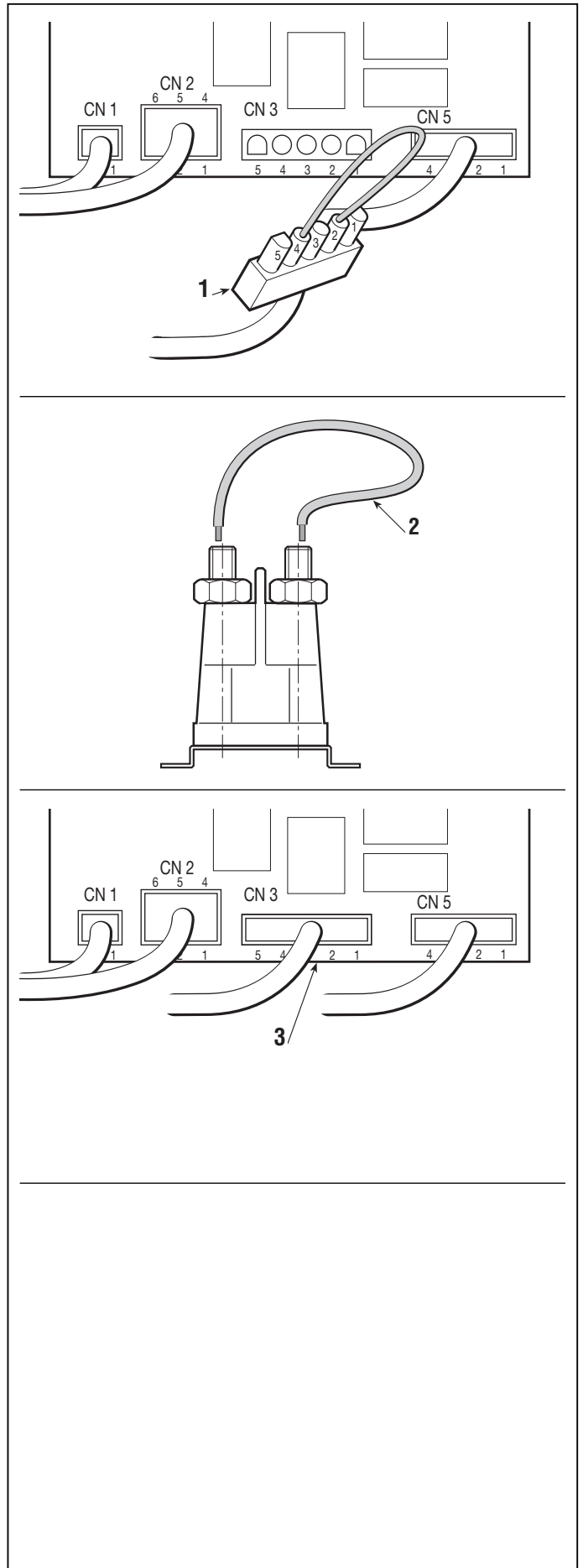

## 7.6.2 ELECTRONIC CARD OPERATION CHECK

from 2006 to  
page 1 / 1

### 7.6 ELECTRONIC CARD OPERATION CHECK

#### A) Card supply

To make this test it is necessary to have:

- The key in the «ON» position
- Connector CN2 (1) disconnected from the card, with all the other connectors attached.

In this situation the pilot lamp should come on.

If the indicator light goes out when connector (1) is inserted, the earth connections of the microswitches must be checked.

#### B) Safety and service supply check

This check is done with the tester in the Voltmeter function (Volt DC 0 ÷ 20), with the black ferrule to earth and the red one on terminal 3 (CN2) of the card's connector (2).

- The key in the «ON» position.

The reading on the tester shows the battery's voltage.

#### C) Checking the operation of the self-setting protection

For this test, put everything in the same situation as in point "A".

By connecting terminal 3 of the CN2 connector of the **electronic card** (3) to the frame's earth, the pilot lamp should go out due to the protection cutting in. Eliminating the connection to earth, the pilot lamp should come on again.

#### NOTE

During this test, the self-setting protection reaches very high temperatures (around 160 °C) which are to be considered normal. Similarly, there might be some smoke inside the transparent box which is due to the overheating of the powder inside.



**WARNING! Do not touch this component of the card until it has cooled down.**

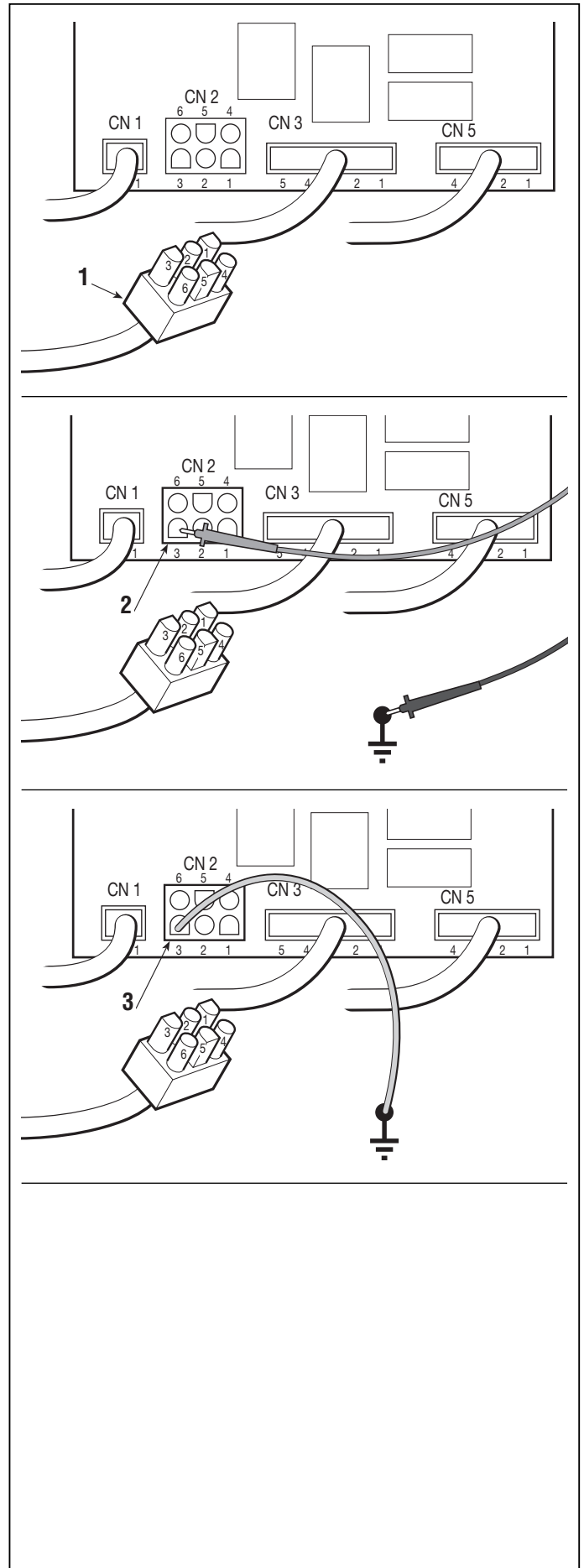

 	<p>7.7.2 <b>RECHARGE CIRCUIT CHECK</b></p>	 	<p>from 2006 to</p> <hr/> <p>page 1 / 1</p>
--	--	--	---

## 7.7 RECHARGE CIRCUIT CHECK

The job of the voltage regulator is to supply a flow of current to the battery at a constant voltage of about 14 -15 Volts, cutting in every time that the output voltage from the generator exceeds this threshold.

A faulty regulator may recharge the battery insufficiently (therefore needing frequent recharging) or, otherwise, may supply overloading that causes the self-resetting protection to cut in.

Before checking the recharge circuit, make sure that:

- all connections are correct;
- the earth connections are firmly connected, especially the earth connections to the regulator;
- the battery is charged and not sulphated [see 7.8];
- the charger fuse is not blown.

### A) Checking the lower charging limit

Start the engine and keep running at minimum.

With the voltmeter tester, measure the voltage at the battery terminals. If the value does not rise but tends to fall, even slowly, it means that the regulator is not charging sufficiently and must be replaced.

If the voltmeter shows no value it means that the charger fuse is blown.

### B) Checking the upper charging limit

Start the engine and take it to maximum speed. With the tester in the voltmeter function, measure the voltage at the battery terminals. The amount should rise and settle at 14-15 Volts after about 10-15 minutes.

If this level is exceeded to a point where the engine stops due to the self-resetting protection device cutting in (at about 16 Volts), it means that the regulator is charging too much and must be replaced.

7.8.1	from 1998 to
<b>CARE AND MAINTENANCE OF THE SEALED BATTERY</b>	page 1 / 1

## 7.8 CARE AND MAINTENANCE OF THE SEALED BATTERY

### A) General information

In a sealed “dual” battery, the electrolyte for each element is carefully measured out during manufacture and sealed at source, in order to ensure maximum performance during the battery’s entire life.

With a battery of this type, it is not necessary to add water or acid, and the cover must never be opened or removed.

### B) Recommendations for correct use

To keep the battery performing at optimum levels and to increase its life, various precautions should be taken:

- always keep the battery fully charged;
- always recharge a flat battery within 1 month, otherwise the elements could be damaged and no longer able to take the charge (sulphated);
- always recharge the battery before and after periods of prolonged inactivity or storage.

### WARNING!

Only recharge with a battery charger at a constant voltage; other battery chargers could damage the battery.

### C) Rules for recharging the battery

Recharging is a particularly important operation for the life of the battery and must be carried out according to these instructions:

- do not recharge the battery when its case is broken or damaged;
- carefully read the instructions for using the battery charger and the battery;
- use the appropriate battery charger;
- recharge at a room temperature of between 10° and 30°C;
- check that the battery does not heat to beyond 50°C while recharging. If it should do so, stop recharging immediately and dispose of the battery since it will be unusable.

With the battery disconnected (and at rest for at least 12 hours) and the tester in voltmeter function, measure the voltage between the terminals.

The amount given (open circuit voltage) gives an indication of the operations to be carried out, as per the following table:

Battery voltage with open circuit	Battery state	Operation to be carried out
> 12.6 Volts	Fully charged	None
< 12.4 Volts	Low charge	Recharge

Check the battery voltage at least 12-24 hours after recharging.

## 7.9.1 FITTING SAFETY MICROSWITCHES

from 2003 to  
page 1 / 1

### 7.9 FITTING SAFETY MICROSWITCHES



#### IMPORTANT

If the microswitches are to function correctly, it is important to follow the exact assembly positions by referring to the drawings that indicate the various usages of each type.

**A** = Free

**B** = Activated

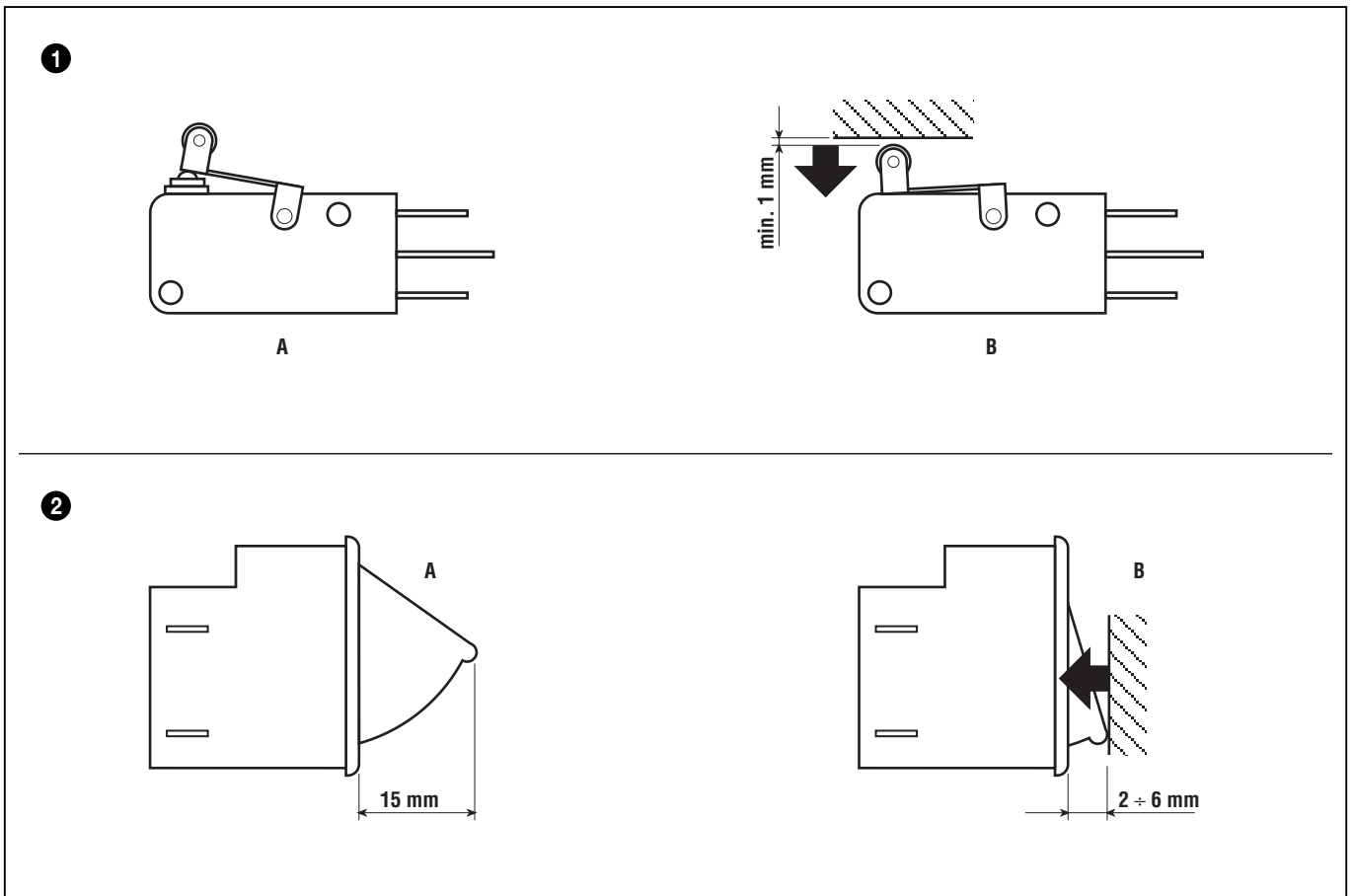

Adjust the seat safety microswitch (1) only by changing the position of the cam (2), after loosening the two fixing screws (3).

This adjustment is correct when you have checked the following:

**A** = seat free: the lower edge of the cam (2) should be touching the microswitch button without activating it.

**B** = seat with the driver in position: the lateral edge of the cam (2) should press the push-button, leaving at least 2-3 mm more travel

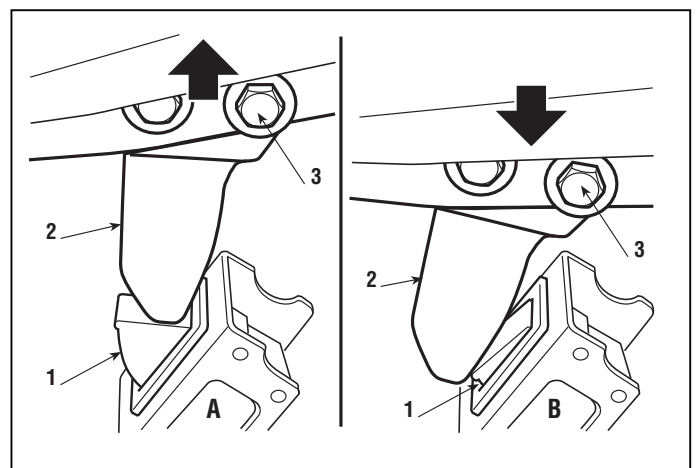

## 7.10.4 ELECTRICAL DIAGRAMS

from 2008 to

page 1 / 1

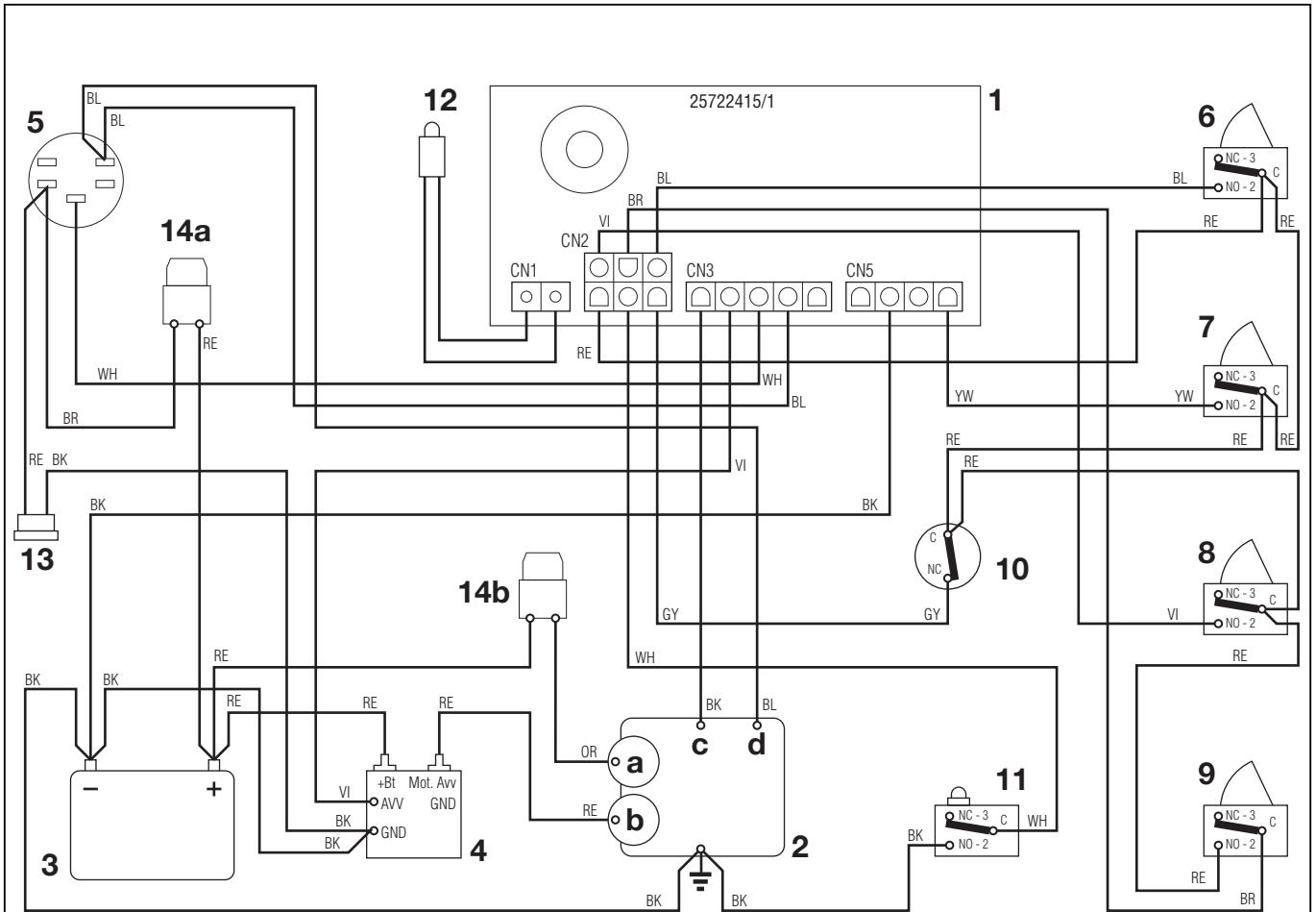

- 1 Electronic card
- 2 Engine
- 2a Generator
- 2b Starter motor
- 2c Engine stop
- 2d Oil
- 3 Battery
- 4 Starter relay
- 5 Key ignition switch
- 6 Blade microswitch
- 7 Brake microswitch
- 8 Grass-catcher microswitch
- 9 Seat microswitch
- 10a Neutral microswitch (▶ in mechanical drive models)
- 10b Neutral microswitch (▶ in hydrostatic drive models)
- 11 Grasscatcher full microswitch
- 12 Pilot lamp
- 13 Recharge connector
- 14a 10 A Fuse
- 14b 25 A Fuse

### CABLE COLOURS

- BK** Black
- BL** Blue
- BR** Brown
- GY** Grey
- OR** Orange
- RE** Red
- VI** Violet
- WH** White

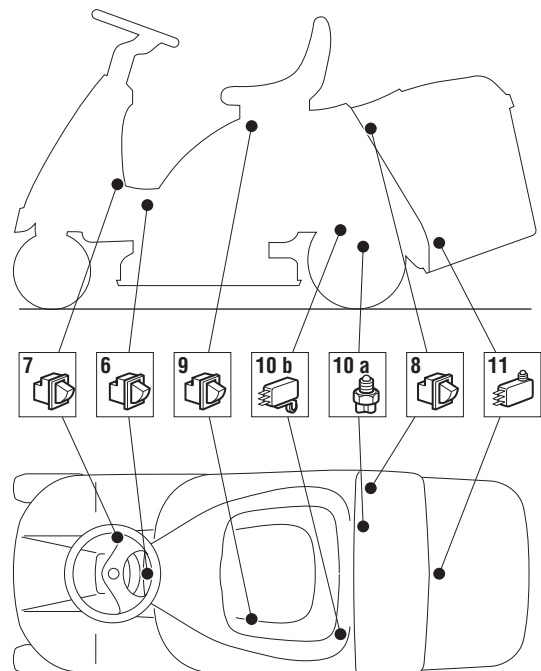

## 8.1.2 - TIGHTENING TORQUES AND ADJUSTMENTS SUMMARY

from 2007 to

page 1 / 1

### 8.1 TIGHTENING TORQUES AND ADJUSTMENTS SUMMARY

#### A) Tightening torques

Below are the specified tightening torques for the fixing bolts on the main parts.

- 1 Screws for engine fastening ..... 25 ÷ 30 Nm
- 2 Screw for engine pulley ..... 45 ÷ 50 Nm
- 3 Screws for rear axle brackets ..... 25 ÷ 30 Nm
- 4 Blade pulley screw ..... 25 ÷ 30 Nm
- 5 Nuts for flanged supports ..... 25 ÷ 30 Nm
- 6 Screw for blade ..... 45 ÷ 50 Nm

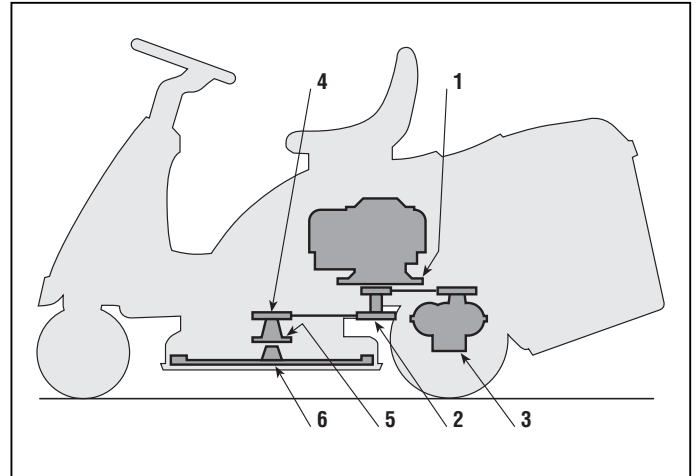

Every section in this manual gives values for all the components involved in each operation.

#### B) Adjustments

Operation	Position	Position of controls	Adjustment
a) Brake adjustment [see 4.3]			<p>Peerless MST 205-541 E Dana 4360-210 LTH 2000 -004C</p> <p>46 - 48</p> <p>Tuff Torq K46T</p> <p>45 - 47</p>
b) Drive belt adjustment [see 4.4]			<p>Peerless MST 205-541 E Dana 4360-210</p> <p>86</p>
c) Blade engagement adjustment [see 4.1]		 	<p>77 - 79</p>



## 8.2.32 - SUMMARY OF MAIN ASSEMBLY AMOUNTS AND CHECKS

from 2006 to

page 1 / 1

### 8.2 SUMMARY OF MAIN ASSEMBLY AMOUNTS AND CHECKS

- 1 Drive belt development
- 2 Blade belt development

