

# STIGA



***WORKSHOP MANUAL***

**Titan 2013-2020**



## **TABLE OF CONTENTS**

- 1 - General instructions
- 2 - Chassis and bodywork
- 3 - Steering system
- 4 - Hydraulic system
- 5 - Control cables
- 6 - Electrical system

All brands, names, logos and trademarks mentioned belong to their respective owners.

© by STIGA - No use of the illustrations or duplication, reproduction or translation, even partial, of the texts in this document may be made without explicit authorisation.

# 1 General instructions

## Contents

<b>1.1 Introduction</b> .....	<b>2</b>	1.3.2 Conditions of the guarantee .....	4
1.1.1 Contingent liability .....	2	<b>1.4 Unpacking, assembly</b> .....	<b>5</b>
1.1.2 How the manual is to be used .....	2	1.4.1 Assembly .....	5
1.1.3 Abbreviations .....	2	1.4.2 Battery .....	6
<b>1.2 Safety precautions</b> .....	<b>2</b>	1.4.3 Final checks .....	7
1.2.1 Symbols, general warnings .....	3	<b>1.5 Safety checks</b> .....	<b>8</b>
1.2.2 Hot parts .....	3	1.5.1 General safety checks .....	8
1.2.3 Moving parts .....	3	1.5.2 Electric safety check .....	8
1.2.4 Lifting and raising .....	3	<b>1.6 Servicing</b> .....	<b>9</b>
1.2.5 Cleaning .....	3	1.6.1 Refrigerant gas air conditioning refill .	10
1.2.6 Tightening torques .....	4	<b>1.7 Technical data</b> .....	<b>11</b>
1.2.7 Sharp edges .....	4	1.7.1 General tightening torques .....	18
1.2.8 Spare parts .....	4	<b>1.8 User guide</b> .....	<b>18</b>
1.2.9 Check .....	4		
<b>1.3 Guarantee</b> .....	<b>4</b>		
1.3.1 Exceptions .....	4		

## General description

This workshop manual is intended for Stiga Titan 540 - 740. Part numbers and product names are given in the tables under the section "Technical data" on page 10.

This manual does not cover repairs to engines and drive line. For matters regarding engines and drive line, contact the General Agent.

This manual and its specifications applies to machines in their original versions. If the machine has been added to, modified or if the engine has been replaced this manual will not correspond to the machine.

The manual is divided into the following chapters:

**Chapter 1 This chapter**

**Chapter 2 Chassis and bodywork**

**Chapter 3 Steering system**

**Chapter 4 Hydraulic system**

**Chapter 5 Control cables**

**Chapter 6 Electrical system**

## 1.1 Introduction

### 1.1.1 Contingent liability

Despite extensive work errors may occur in this publication.

The author is not liable for incorrect or missing information.

GGP SE reserves the right to make alterations to the product without prior notification at regular intervals. Information in this publication is based on information available at the time of production. Images and photographs may deviate from the relevant machine models, which means that they apply to several machine models.

### 1.1.2 How the manual is to be used.

In order to make this manual easy to understand we have divided the manual into the main components of the machine. Each component therefore has its own chapter.

Each chapter is divided into sections. There is a quick guide on the cover, which refers to the different chapters. There is a table of contents in each chapter so that it is easy to find the section that you are looking for.

The headings in this manual are numbered in accordance with the following example:

“1.2.1 Symbol, general warnings” is a subheading to “1.2 Safety precautions” and is included under this heading. When referring to headings, only the number of the heading is normally specified. For example. “See 1.2.1”.

### 1.1.3 Abbreviations

Following abbreviations are used in this manual:

PTO	Power Take Off
ROPS	Roll Over Protection System
Aux	Auxiliary

## 1.2 Safety instructions

This manual is primarily written for trained mechanics. The manual is, however, written in such a way that the user can also carry out certain simple repairs. Basic knowledge of repair and tool use is a precondition of achieving a satisfactory result.

Contact a qualified repairer if the knowledge is not sufficient to carry out repairs. During the guarantee period, all repair work must be carried out by an authorised workshop for the guarantee to remain valid.

The following points must be observed for the machine to function perfectly:

- Follow the maintenance schedule.
- Be alert to any sudden vibration or noise to avoid damage to the machine.
- Always use genuine spare parts.
- Follow the descriptions in this manual carefully. Never jump several stages or instructions.



### 1.2.1 Symbols, general warnings



#### Warning!

This symbol indicates that personal injury may result if the instructions are not followed.

Note!



This symbol indicates that damage to material or equipment may result if the instructions are not followed.

**Note** This text means that you should read carefully.

### 1.2.2 Hot parts

Note that the engine and exhaust system heat up during operation.

To avoid injury always allow the machine engine and exhaust system to cool before starting any repair or service work.

### 1.2.3 Moving parts

All machines are equipped with v-belt transmission. Always switch off the motor and remove the key before carrying out any service or repair work on the machine.

Always take great care, when systems with moving parts are to be tested, to avoid personal injury.

Always use genuine spare parts.

### 1.2.4 Lifting and raising

Before work under the machine can be carried out, the lifting equipment or jack capacity must be checked.

### 1.2.5 Cleaning

Clean the machine before starting repair work. Dirt that penetrates sensitive components can affect the service life and function of the machine.

When the machine is used to spread salt, daily cleaning and additional maintenance are required.

This is due to the corrosive action of salt towards painted parts.

- 1) The machine must be washed with non-heated water. Hot water will cause a chemical reaction which accelerates the corrosive process.
- 2) The wet machine must not be kept in a closed, heated environment.

Additional maintenance consists in protecting painted and galvanised parts (frame, rims, motor, etc.) with a professional protective wax in order to prevent possible corrosion. For instance, Divinol Konservierungswachs has given excellent anti-corrosion results.



### 1.2.6 Tightening torques

Unless otherwise stated, the tightening torques given in section 1.7.1 apply to the relevant screw. This does not apply to self-tapping screws, which are mainly used for assembling body components.

### 1.2.7 Sharp edges

Look out for sharp edge's, especially when working with the cutting deck. The blades can be extremely sharp. Always use gloves when working with the blades.

### 1.2.8 Spare parts

Always use genuine spare parts for repairs.

### 1.2.9 Check

Each component that is removed in conjunction with service, must be checked for damage.

Look out for: wear, cracks, out of shape, straightness, pitting, discolouration, noise and jamming.

## 1.3 Guarantee

### 1.3.1 Exceptions

The guarantee does not cover damage due to:

- Failure by users to acquaint themselves with accompanying documentation.
- Carelessness.
- Incorrect and non-permitted use or assembly.
- The use of non-genuine spare parts.
- The use of accessories not supplied or approved by Stiga.

Neither does the guarantee cover:

- Wear components such as blades, belts, wheels, battery and cables.
- Normal wear.
- Engine and transmission. These are covered by the engine manufacturer's guarantees, with separate terms and conditions.

The purchaser is covered by the national laws of each country. The legal rights of the purchaser laws are not restricted by this guarantee.

### 1.3.2 Conditions of the guarantee

The guarantee card must be filled in with all information and then sent to Stiga or to the Stiga dealership.

In the event of a claim a record of previous services must be shown by a copy of the service book.

## **1.4 Unpacking, assembly**

All Stiga Titans have undergone an extensive program of checks prior to delivery. The machines are supplied as fully assembled as possible.

Thanks to this, final assembly after delivery is quick and easy.

- !** Note!  
• The machine must remain on the pallet while it is unpacked and assembled.

### **1.4.1 Assembly**

See assembly instructions (separate book).

## 1.4.2 Battery

The battery is the sealed type, which means that the electrolyte level cannot be adjusted.

The charging level of the battery can be read off on an indicator, positioned on the upper section of the battery. The charging level can also be read off using a voltmeter. The following then applies:

12.7 V Fully charged

12.4 V Half charged

12.0 V Drained

### Warnings!



**Do not wear rings, metal bracelets, necklaces or other similar metal items when working with batteries. That can lead to short circuits or fires.**



**The battery must be fully charged before it is used for the first time. The battery should always be stored fully charged. If the battery is stored while discharged, serious damage can occur.**



**If the cables are disconnected/connected in the wrong order, there is a risk of a short-circuit and damage to the battery.**



**If the cables are switched it can result in damage to the alternator and battery.**



**The engine must never be run with the battery disconnected. It can result in damage to the alternator and electrical system.**

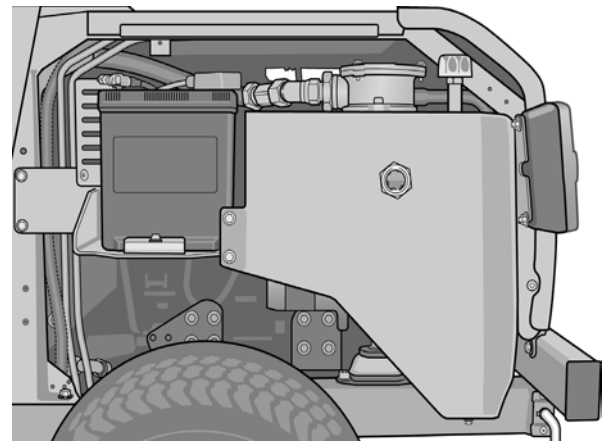

### Charging with the engine

The battery is also charged using the engine's alternator as follows:

1. Install the battery in the machine.
2. Place the machine outdoors or install an extraction device for the exhaust fumes.
3. Start the engine according to the instructions in the instructions for use.
4. Allow the machine to run continuously for 45 minutes (does not apply to fully discharged battery).
5. Stop the engine. The battery will now be fully charged.

This should be done before longer storage periods.

### Charging using battery charger

The battery must be charged at 4A - 8A. Higher charging current will damage the battery.

### 1.4.3 Final checks

#### Actions before starting

Carry out the following before starting the machine:

- Check/top up with fuel.
- Check/adjust the engine oil level.
- Check/adjust the coolant level.
- Check to make sure that the air filter indicator has not been tripped.
- Check that the water separator and fuel filter taps are open.
- Check that the water separator does not contain water. Drain if necessary.
- Check the oil level in the hydraulic tank. The oil level is visible in the sight glass.
- Carry out safety checks.
- Check that the disengagement lever is in the inner position. Refer to the machine's instructions for use.
- Check that the distance from the centre of the wheel to the ground is the same for all 4 wheels. If not adjust the air pressure. See image below.

#### Test driving

Run the engine to operating temperature at idle speed before test driving. For more in-depth instructions see "6.8" in the instructions for use. Run the machine for a few minutes. Test all functions. Check in particular that the safety equipment functions. If the machine is to be supplied with a cutting deck or other equipment, this equipment must be installed before test driving the machine.

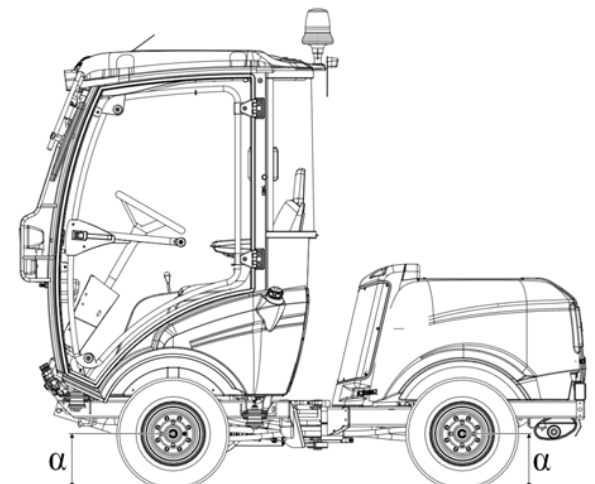

## 1.5 Safety checks

### 1.5.1 General safety checks

Object	Result
Fuel lines and connections.	No leakage.
Power cables.	All insulation intact. No mechanical damage.
Exhaust system.	No leakage in the connections. All screws tightened.
Hydraulic hoses.	No leakage. No damage.
Drive the machine forwards/backwards and release the drive/service brake pedal (the right pedal).	The machine must stop within 15 metres.
Test driving.	No unusual vibrations. No unusual noise.

### 1.5.2 Electric safety check

Status	Action	Result
The clutch/brake pedal not depressed. PTO not activated.	Attempt to start.	The engine should not start.
The clutch/brake pedal depressed. PTO activated. (The control for the implement lifter must be in floating position in order for the power take-off to be activated.)	Attempt to start.	The engine should not start.
Engine running. PTO activated.	The operator leaves the seat.	PTO should disengage.
Control for implement lifter not in floating position.	Attempt to engage PTO.	PTO cannot be engaged.

## 1.6 Service

Each new machine is supplied with a service book. The service log should be stamped at every service carried out by an authorised workshop. The service book is part of an active aftermarket program and must be stored in a safe place during the

lifetime of the machine. The service book must accompany the machine if it is sold as used.

The service points are given in the table below. Descriptions of how the procedures are to be carried out are given after the table.

Service point	Hours of operation/Calendar months		See the instructions
	1st time	Interval	
Water separator, check		50/-	in the instructions for use paragraph maintenance
Filter in water separator, cleaning			
Fuel filter, replace		400/-	
Tyre pressure, check, adjust			
Engine oil, filter, change	50/12	200/12	
Hydraulic oil, change/clean		400/12	
Wheel motors , change oil	50/12	200/12	
Belt transmissions, check	50	200/-	
Cooling system, change coolant		1000/24	
Battery, check		50/-	
Air filter, clean pre-filter		200/-	
Air filter, change inner filter		200/-	
Lubrication		50/-	
Tightening / control of hydraulic couplings and hydraulic tubes	50	50/-	
Adjusting valves		1000/-	
Grinding valves		2000/-	
Tank venting valve, change/ clean		1000/24	
Check the correct tightening of the fix screw of the lift arms support	50/12	400/12	See the drawing (1)
Check the tightening torque of the screws (A) and (B) of the joint.	50/12	400/12	See the drawing (2)

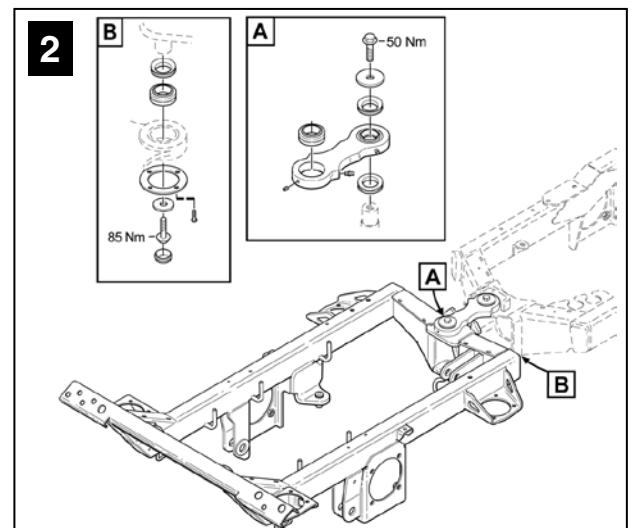
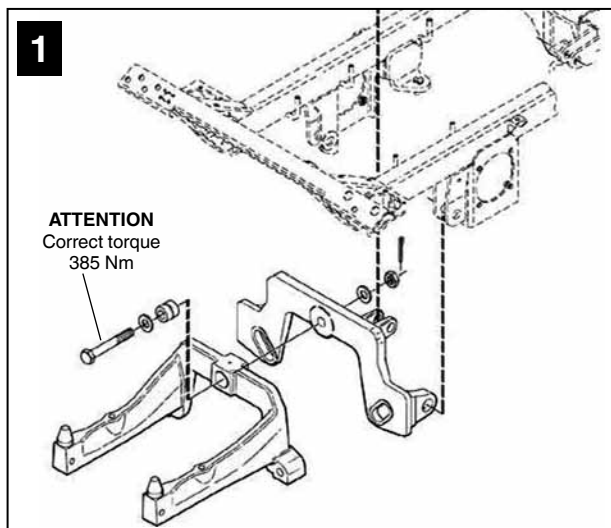

### 1.6.1 Refrigerant gas air conditioning refill (only for machines equipped with air conditioning system)

The air conditioning system uses a refrigerant gas type R134a. The quantity used to fill a new system is 0.9 kg.

The charging station must be connected to the system at the points shown in the following

ing pictures:

- the red connector inserts the refrigerant gas,
- the blue connector creates a vacuum.

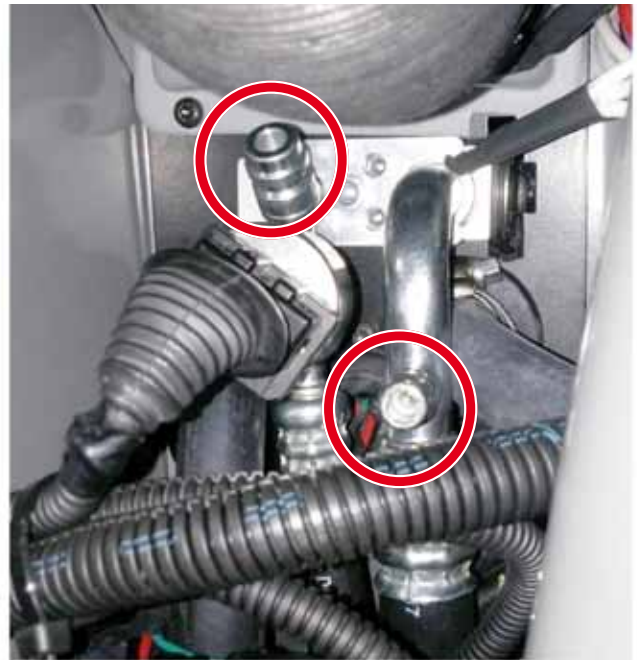



## 1.7 Technical data

Titan	540 D	740 D	740 DC	740 DCR
	13-7454-11	13-7460-11	13-7461-11	13-7462-11
<b>Engine</b>	Yanmar	Yanmar	Yanmar	Yanmar
<b>Type</b>	4 stroke Diesel IDI	4 stroke Diesel DI	4 stroke Diesel DI	4 stroke Diesel DI
<b>Cylinders</b>	3	3	3	3
<b>Cylinder volume</b>	1116 cc	1331 cc	1331 cc	1331 cc
<b>Cooling system</b>	Water cooled	Water cooled	Water cooled	Water cooled
<b>Gross output at 3000 rpm</b>	19.2 kW	23.8 kW	23.8 kW	23.8 kW
<b>Engine speed at full power output</b>	3000 rpm	3000 rpm	3000 rpm	3000 rpm
<b>Idle speed</b>	1400 rpm	1400 rpm	1400 rpm	1400 rpm
<b>Lower temperature limit (°C)</b>	-20	-20	-20	-20
<b>Cold start assistance</b>	Yes	Yes	Yes	Yes
<b>Emission standards</b>	Eu: Stage 3A (97/68/EC)	Eu: Stage 3A (97/68/EC)	Eu: Stage 3A (97/68/EC)	Eu: Stage 3A (97/68/EC)
<b>Fuel system</b>				
<b>Fuel pump</b>	Mechanical	Electric	Electric	Electric
<b>Fuel type</b>	Diesel (EN590:96)	Diesel (EN590:96)	Diesel (EN590:96)	Diesel (EN590:96)
<b>Alternative fuel</b>	Max 5% RME (EN24214)	Max 5% RME (EN24214)	Max 5% RME (EN24214)	Max 5% RME (EN24214)
<b>Water separator</b>	Yes	Yes	Yes	Yes
<b>Fuel filter</b>	Paper filter	Paper filter	Paper filter	Paper filter

Titan	540 D	740 D	740 DC	740 DCR
	13-7454-11	13-7460-11	13-7461-11	13-7462-11
<b>Hydraulic system</b>				
<b>Drive system</b>	Permanent 4x4, hydraulic wheel motors	Permanent 4x4, hydraulic wheel motors	Permanent 4x4, hydraulic wheel motors	Permanent 4x4, hydraulic wheel motors
<b>Max. speed</b>	20km/h	20km/h	20km/h	20km/h
<b>Wheel size, front/rear</b>	20x10.00x10, 6ply	20x10.00x10, 6ply	20x10.00x10, 6ply	20x10.00x10, 6ply
<b>Steering</b>	Hydraulic	Hydraulic	Hydraulic	Hydraulic
<b>Power take off (PTO), hydraulic</b>				
<b>Extra hydraulic circuits, front</b>	2	2	2	2
<b>Extra hydraulic circuits, rear</b>	-	1	1	1
<b>AUX pump flow/pressure</b>	10.5 l/min / 125 bar	10.5 l/min / 125 bar	10.5 l/min / 125 bar	10.5 l/min / 125 bar
<b>PTO pump flow/pressure</b>	42 l/min / 220 bar	42 l/min / 220 bar	42 l/min / 220 bar	42 l/min / 220 bar
<b>Air filter</b>				
<b>Type</b>	5" Double filter, dry	5" Double filter, dry	5" Double filter, dry	5" Double filter, dry
<b>Counter pressure indicator</b>	Yes	Yes	Yes	Yes
<b>Extra large filter for extended cleaning intervals</b>	Yes	Yes	Yes	Yes
<b>Weights</b>				
<b>Machine basic weight.</b>	700 kg	720 kg	950 kg	965 kg
<b>Max. total weight</b>	1400 kg	1400 kg	1400 kg	1400kg
<b>Max. load front/rear axle*</b>	900 kg/ 900 kg	900 kg/ 900 kg	900 kg/ 900 kg	900 kg/ 900 kg
<b>Max. lift force**</b>	5.2 kN	5.2 kN	5.2 kN	5.2 kN
* Axle load must never be less than 30% of the total weight. See page 13.				
**See image page 13. NOTE! Take the weight balance into consideration.				

Titan	540 D	740 D	740 DC	740 DCR
	13-7454-11	13-7460-11	13-7461-11	13-7462-11
<b>Operator position</b>				
<b>Seat setting</b>	Fully adjustable	Fully adjustable	Fully adjustable	Fully adjustable
<b>Steering wheel setting</b>	Fully adjustable	Fully adjustable	Fully adjustable	Fully adjustable
<b>Armrest</b>	Yes	Yes	Yes	Yes
<b>Extended backrest</b>	Yes	Yes	Yes	Yes
<b>Fuel gauge</b>	Yes	Yes	Yes	Yes
<b>Lighting, front</b>	Yes	Yes	Yes (Work lighting)	Yes (Work lighting)
<b>ROPS</b>	Yes	Yes	-	-
<b>Cab with heating</b>	-	-	Yes	Yes
<b>Cab with AC</b>	-	-	-	Yes
<b>Hour meter</b>	Yes	Yes	Yes	Yes
<b>Volumes (L)</b>				
<b>Volume in the fuel tank</b>	42	42	42	42
<b>Oil, engine</b>	3,4	3,6	3,6	3,6
<b>Oil, wheel motors</b>	0,1-0,15	0,1-0,15	0,1-0,15	0,1-0,15
<b>Oil, hydraulic system</b>	14-15	14-15	14-15	14-15
<b>Coolant</b>	4,3	4,3	4,3	4,3
<b>Washer fluid</b>	2,7	2,7	2,7	2,7
<b>Trailer weight, max.</b>				
<b>Unbraked</b>	500 kg	500 kg	500 kg	500 kg
<b>Braked</b>	800 kg	800 kg	800 kg	800 kg

### Axle loads\*

Axle load must never be less than 30% of the total weight. This applies to both raised and lowered implements.

Example: If a machine weighs 1000 kg, the weight must not be less than 300 kg over the least laden axle.

**Note Important!**

**Axle load must not exceed 900 kg on the most laden axle.**

### Lift force \*\*

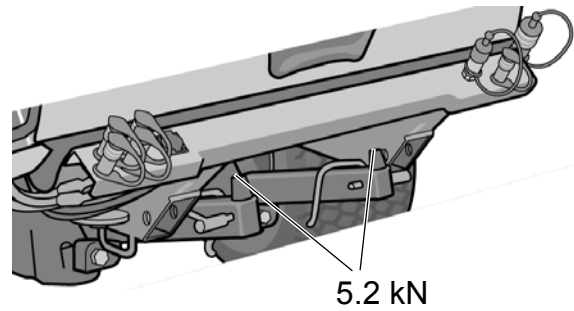

### Dimensions of machine

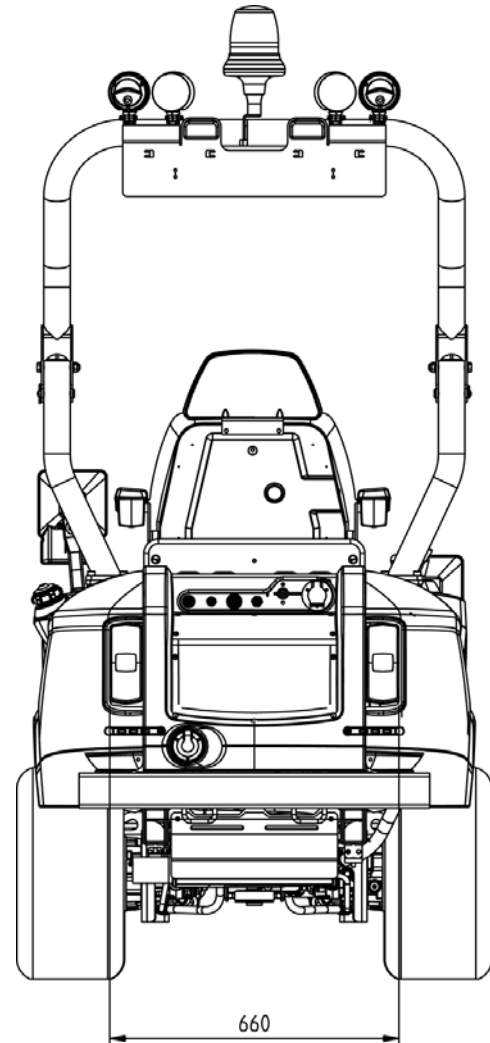
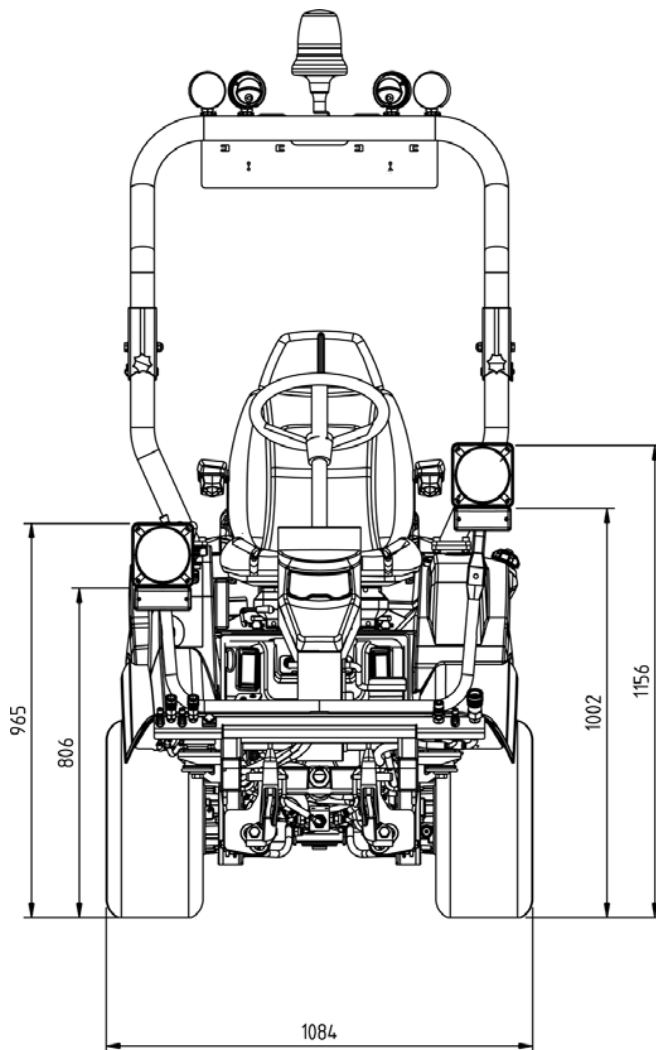

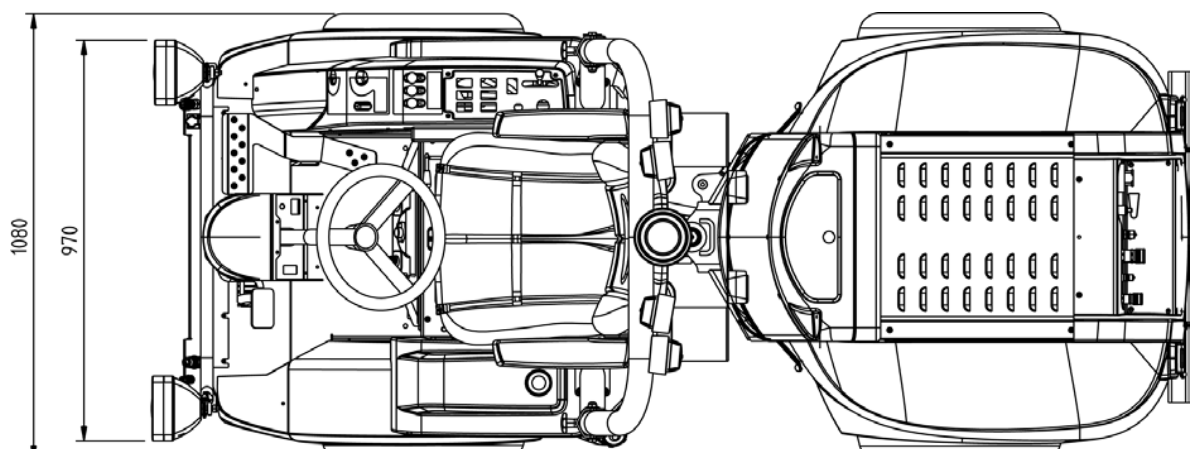
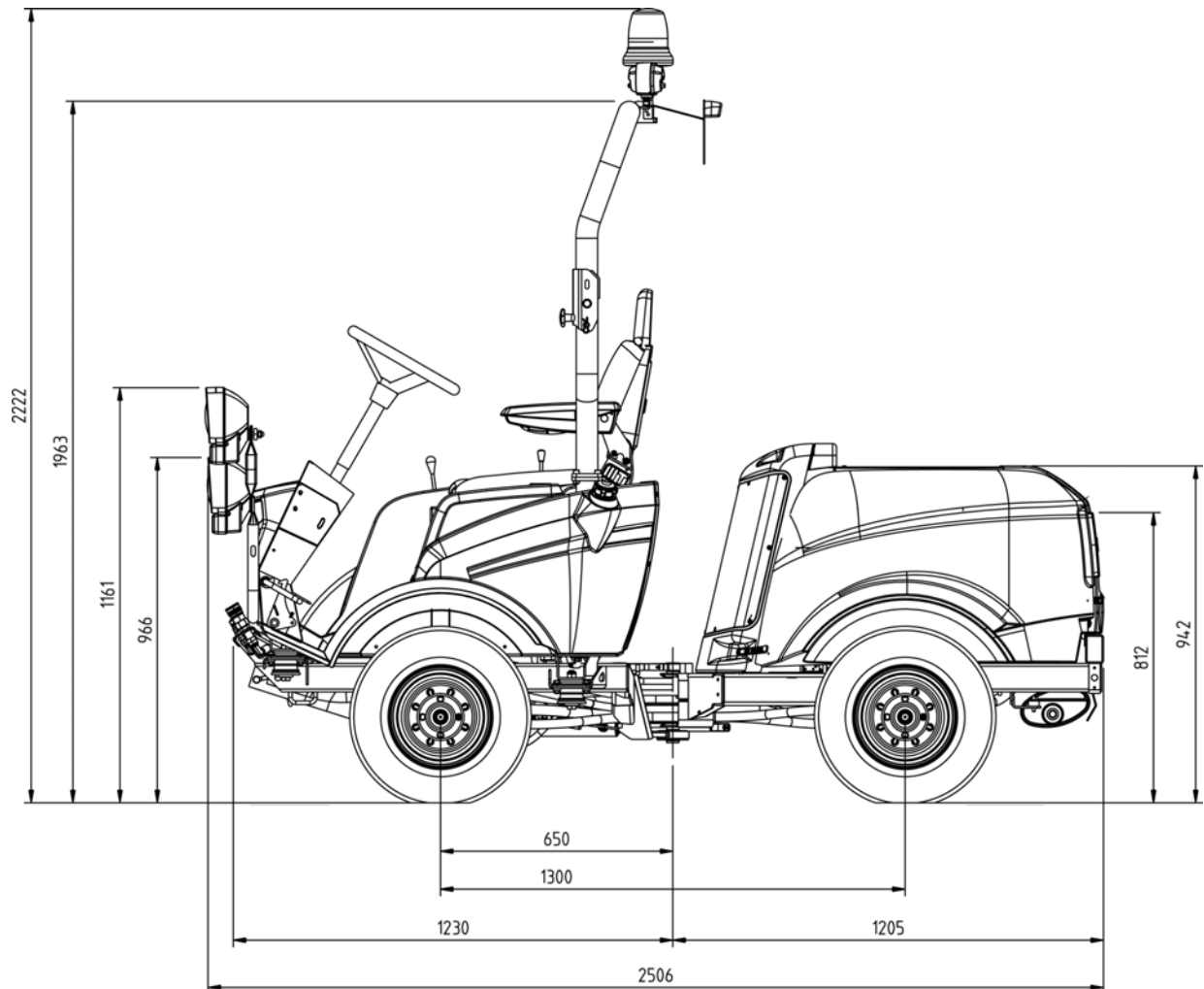

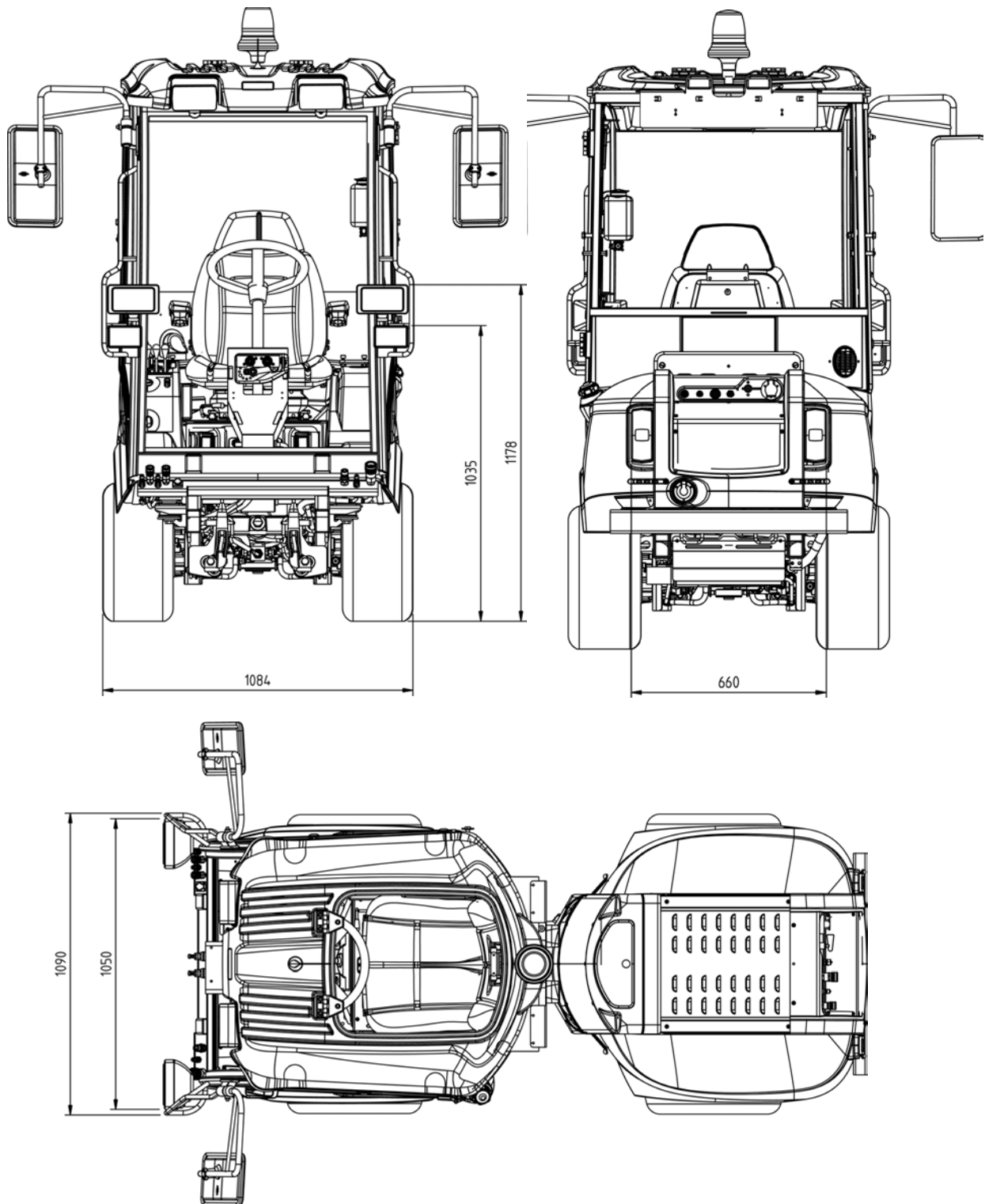

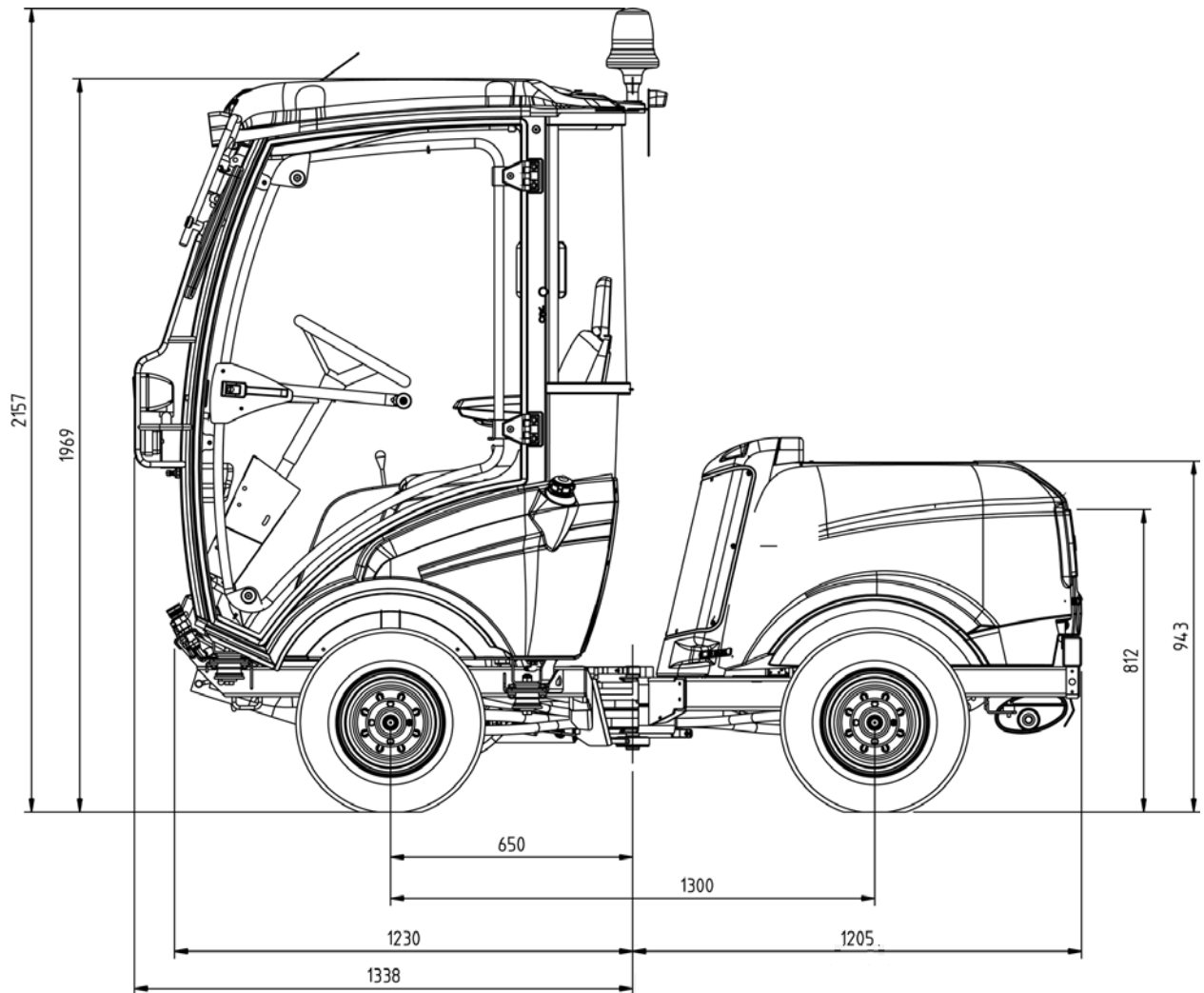

### 1.7.1 General tightening torques

Tightening torques for screws and nuts unless otherwise specified:

Thread	Torque
M5	5 Nm
M6	9 Nm
M8	22 Nm
M10	45 Nm

## 1.8 User guide

Certain procedures, for example changing the engine oil, replacing filters etc. refer to the instruction manual supplied with the machine.

Instructions for use are available at the GGP Parts & Service website, <http://www.ggppartsandservice.com>.

For more product information visit the Stiga website, <http://www.stiga.com>.



## 2 Chassis and bodywork

### Contents

<b>2.1 Description .....</b>	<b>20</b>	<b>2.5 Lubrication .....</b>	<b>30</b>
<b>2.2 Removal/Installation of covers .....</b>	<b>21</b>		
2.2.1 Removal of engine covers .....	21		
2.2.2 Removing the front side cover and the control panel .....	22		
<b>2.3 Radiator .....</b>	<b>23</b>		
2.3.1 Description .....	23		
2.3.2 Dismantling .....	23		
2.3.3 Assembly .....	24		
2.3.4 Topping up with coolant .....	25		
<b>2.4 Cab .....</b>	<b>26</b>		
2.4.1 Changing the windscreen .....	26		
2.4.2 Adjusting door .....	27		
2.4.3 Windscreen wiper motor .....	27		
2.4.4 Light setting .....	28		
2.4.5 Removing the cab .....	29		

### General description

To facilitate driving, use of implements and to make it simpler for the user, the machine is fitted with different types of auxiliary equipment. The auxiliary equipment consist of hydraulic, electrical or mechanical devices. The chapter will also cover the cab.

This chapter will give a short description of the functions of the different pieces of equipment and how they are repaired.

## 2.1 Description

The chassis is built around an articulated frame with the pivot in the centre. This means that both the front and rear wheels participate in the turning movement, where the rear wheels follow in the tracks of the front wheels. This is a great advantage when mowing around trees or corners. The rear wheels never take a shorter route and hit obstacles.

This configuration also means that an optimal unmown circle is created when the machine is operated at full lock.

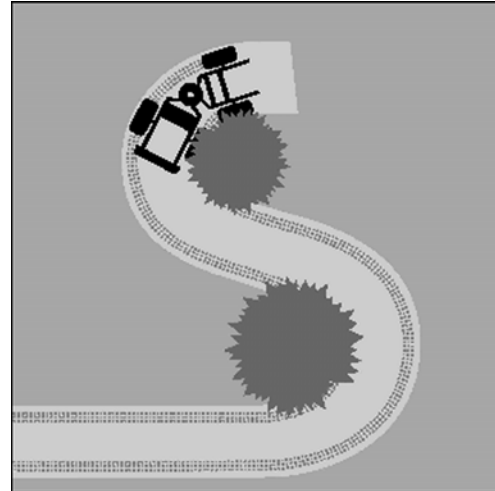

The articulated frame also pivots vertically,  $\pm 10^\circ$  when the machine is straight ahead and  $\pm 2^\circ$  at full lock. This makes it possible for all four wheels to press evenly against the ground when the machine is driven on uneven surfaces.



The chassis is equipped with controls that operate the machine functions and implements. I.e. cables and shafts between the brake and pedal, lift mechanism, cable to the throttle etc.

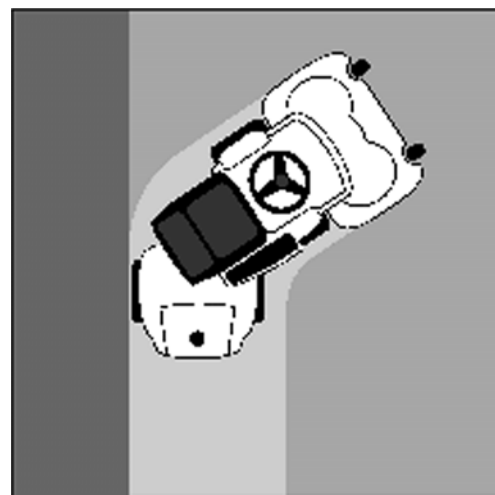

## 2.2 Removal/Installation of covers

### 2.2.1 Removal of engine covers

- Remove the front and rear rubber straps A (4x) on the side covers.
- Remove the rear engine cover by unscrewing the five screws B (3x), C (2x) behind the side covers.
- Remove the upper cover by unscrewing the screws D (4x) (and B (3x), same screws as the rear engine cover).
- Remove the front cover by releasing the locking knobs E (2x).

Installation is in reverse order, remember that the two locking knobs are adjustable.

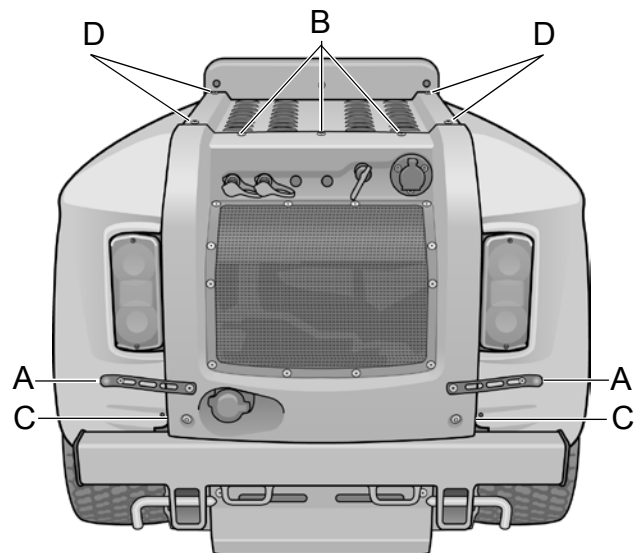
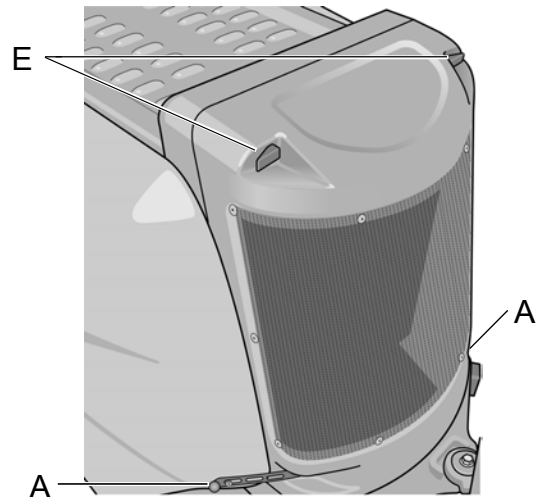

### 2.2.2 Removing the front side covers and the control panel

Components are accessed as follows:

1. Remove the cover by twisting the screw with clamp A, see image to the right.
2. To remove the whole side cover remove the screws B (5x) for machines with cab; machines without a cab have screws B (5x), C (2x) securing the cover. When reinstalling use silicone spray along the sealing trim.
3. If necessary, remove the other cover by first removing the three control knobs for the hand lever valves, twist while pulling upwards. Then unscrew screws D (4x), E (2x), F.

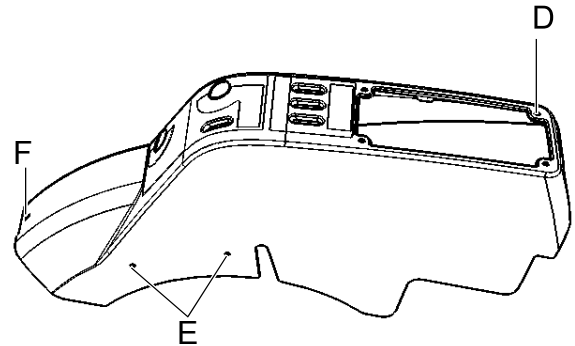
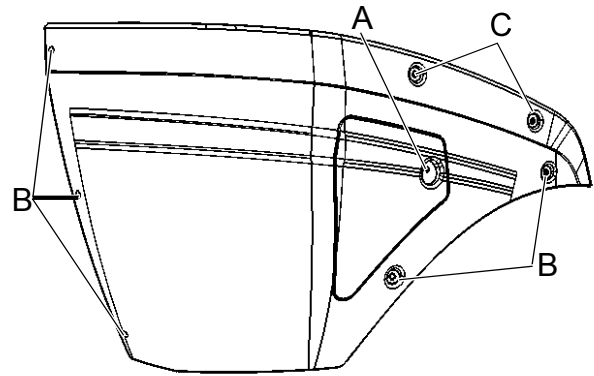

## 2.3 Radiator

### 2.3.1 Description

The radiator is intended to keep the engine temperature and oil temperature constant during operation. It is very important that the coolant flows freely through the radiator.

### 2.3.2 Dismantling

**Note** Take care not to damage the radiator cooling fins when installing or removing.

Remove the radiator as follows:

1. Remove all engine covers, see "2.2.1".  
Remove the plate X which slides under the radiator.



#### Warning!

**The coolant is very hot immediately after operation. Allow the engine to cool before draining the coolant..**

2. Place a container under drain screw A. Then drain the radiator by unscrewing the drain screw.
3. Install the vacuum pump according to "4.8" or drain the hydraulic oil. We recommend that you use a vacuum pump.
4. Remove the return hose B from the PTO block at the radiator. Use a 32 mm socket.
5. Disconnect the hose C to the return oil filter at the filter. Use a 38 mm socket.
6. Disconnect the upper and lower coolant hoses, upper D and lower E. Use a hose clip driver.
7. Pull off hose F for the expansion tank.

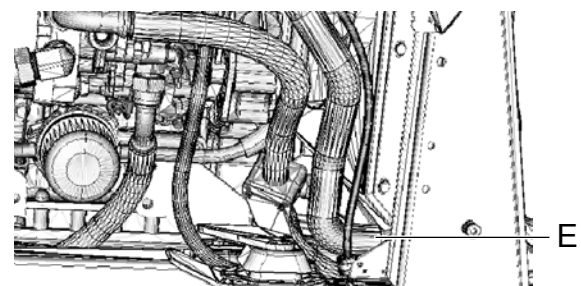
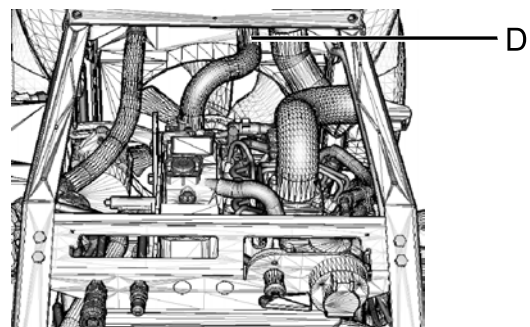
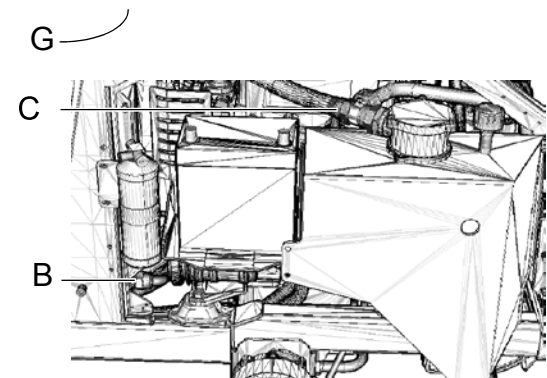
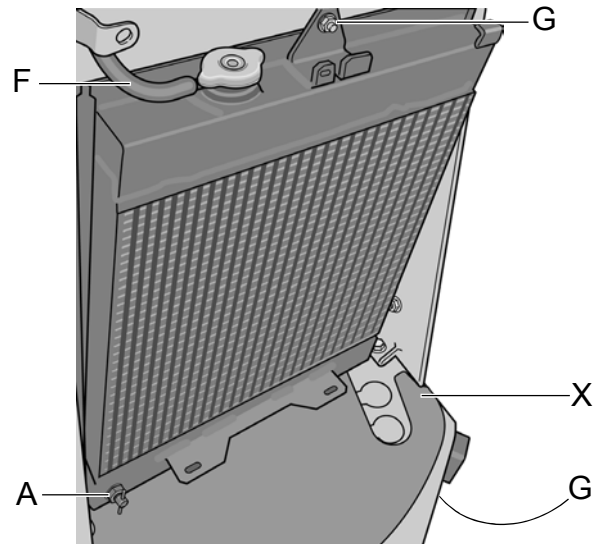

8. Unscrew the upper screw G that fastens the radiator. Use a 13 mm socket.
9. Pull out the upper section of radiator so that coupling H for the hose to the return oil filter is visible and disconnect the fan from the radiator. Use a 32 mm socket.
10. Unscrew the remaining screws G (2x) that secure the radiator from underneath. Use a 13 mm socket.

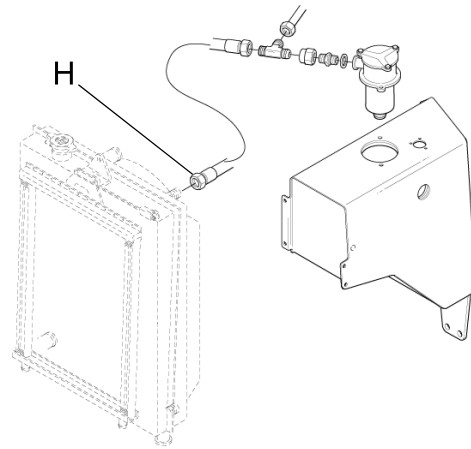

### 2.3.3 Assembly

Installation of the radiator is in reverse order.

### 2.3.4 Topping up with coolant

The coolant must meet the following requirements:

- Always use a mixture of refrigerant and water. Never use just water.
- Mix the water and refrigerant according to the refrigerant supplier's instructions.
- Never mix different refrigerants.
- Use soft water (no calcium content), distilled or demineralised water.



#### Warning!

**If the radiator cap is opened when the engine is hot there is a risk of serious burn injuries from hot water that may spray out.**

Top up as follows:

1. Remove the front engine cover.
2. Check that all the plugs in the cooling system are installed and sealed.
3. Check that the drain screw D is closed and sealed.
4. Check that all the hoses in the cooling system are intact and sealed.
5. Unscrew the radiator cap A.
6. Slowly fill the radiator with coolant. Air bubbles must not form when filling. Fill up to the filler hole.
7. Reinstall the radiator cap.
8. Open the cap on the expansion tank B and top up the mixture to the lower mark, which is the level when the engine is cold.
9. Close the cap for the expansion tank.

10. Run the engine to operating temperature and check the level in the expansion tank. The level should now be at the upper mark C, which is the level for when the engine is hot.
11. If the level is not up to the upper mark, allow the engine to cool and then top up with coolant in the expansion tank.

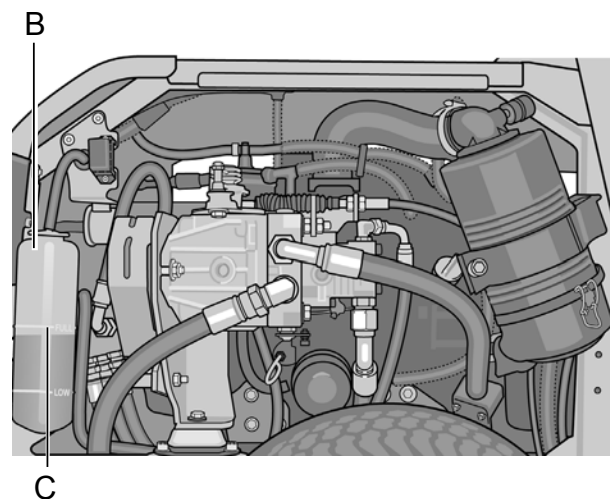
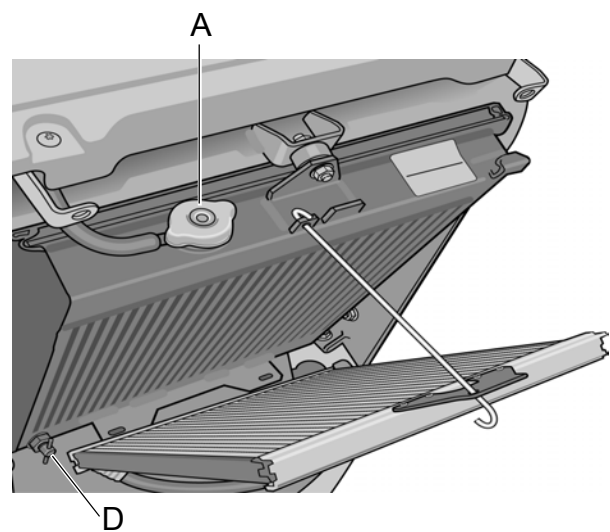

## 2.4 Cab

### 2.4.1 Changing the windows

Remove the different windows as follows:

#### Replacing the side window

1. Unscrew the screws A (5x) and lift out the window.
2. Install a new seal strip on the new side window.

When you install the new window ensure that you position the plates, rubber gaskets and washers in the same place as the previous window. See image.

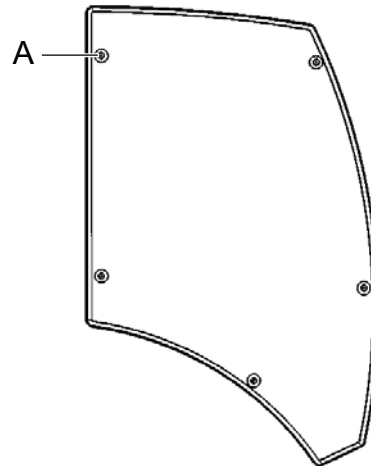

#### Changing door window

1. Remove the door cylinder from the door frame.
2. Remove the whole door by unscrewing the screws B (2x).
3. Remove the door handle, unscrew the screws C (2x), D (2x), E.
4. Unscrew the remaining screws F (2x) and lift out the window.
5. Install a new seal strip on the new side window.

Reassemble in reverse order.

Make sure that the plates, rubber gaskets, washers and seal at the handle are in the same place as in the previous window. See image.

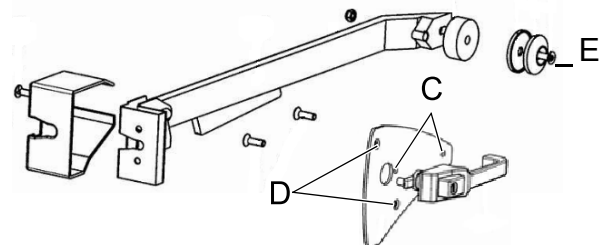
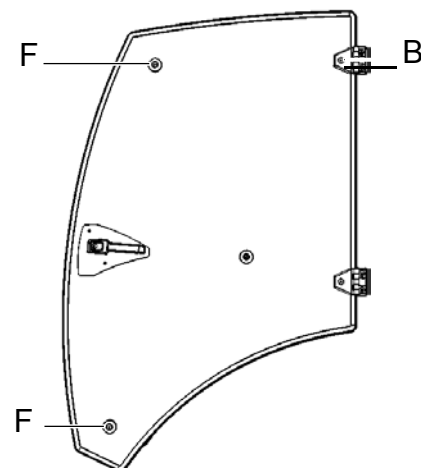



### 2.4.2 Adjusting door

1. Slacken off the existing nuts enough that the locking pin can be moved.
2. Move the locking pin (height, side-ways) to the desired position and then tighten the nuts again.

If incorrectly set there is a risk that the door cannot be closed, or that there is play between the door and the cab that allows water to leak in.

### 2.4.3 Windscreen wiper motor

1. Remove the screw on the plastic cover that covers the windscreen wiper motor.
2. Unscrew the two wiper arms that are each secured by a nut.
3. Undo the lower screws A (2x).
4. Slacken off the nuts (B) (2x) inside the wiper arms.
5. Lift off the washer fluid tank.
6. Remove the lock rings C (2x) and remove the washers and rubber gas-kets.
7. Remove the plastic cover that covers the windscreen wiper motor.
8. Then lift off the motor.

Reassemble in reverse order.

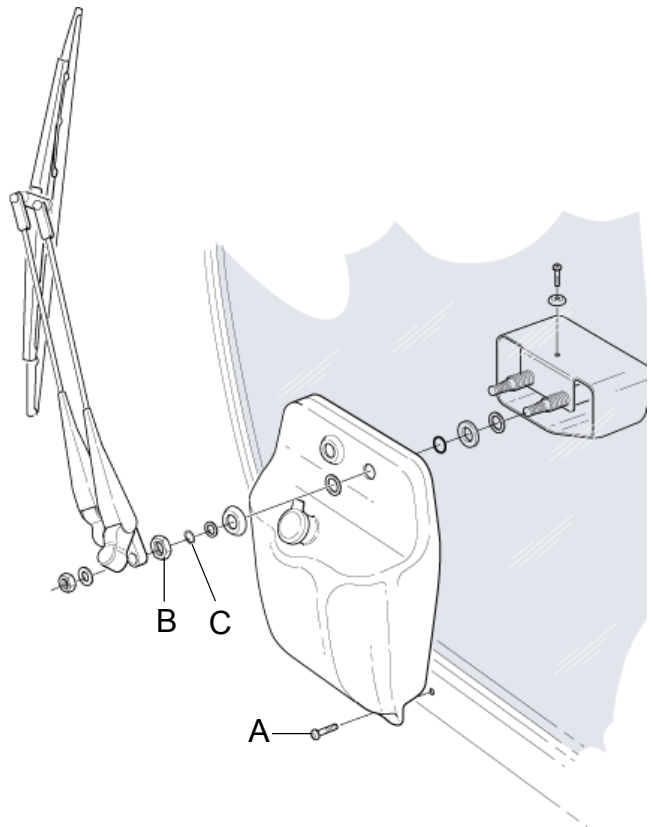

### 2.4.4 Light setting

The machine headlamps have dipped beam. These must be set according to local regulations. A guideline is shown in the image below. The same applies for machines without cab with road kit.

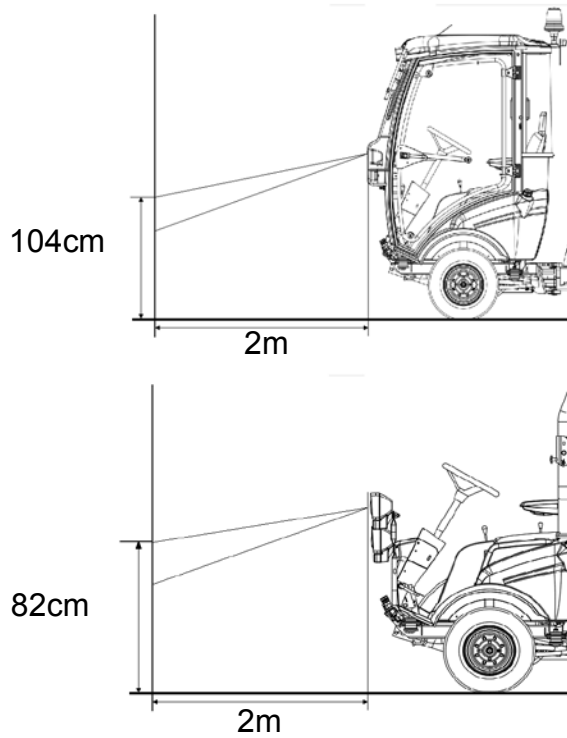

### 2.4.5 Removing the cab

Remove the cab as follows:

1. Remove the little side front cover by turning the screw with the bracket. See "2.2.2" Disconnect the switch that goes to the cab marked Cabin.
2. Slide the seat as far forward as possible.
3. Remove the steering wheel by removing the screw on the steering wheel shaft.
4. Remove the document holder by unscrewing the screws (4x).
5. Remove the air intake by unscrewing the screws (2x).
6. Remove the mat on the floor.
7. Secure the cab in the lifting device in the four mountings A (2x), B (2x) on the roof. Use lifting eyes, 12 mm with the DIN 580 standard.
8. Slacken off the front screws C (4x) that are below the windscreen inside the cab.
9. Slacken off the screws D (8x) that are (4x) and (4x) on each side of the seat.
10. Then carefully lift off the cab.

**Note** When lifting do not forget to take the weight of the cab, which is 146 kg, into consideration.

Reinstall the cab in reverse order. After installation check the light settings, see "2.4.4".

Note!

**!** It is important that the cab is removed in accordance with the instructions so that no components are damaged.

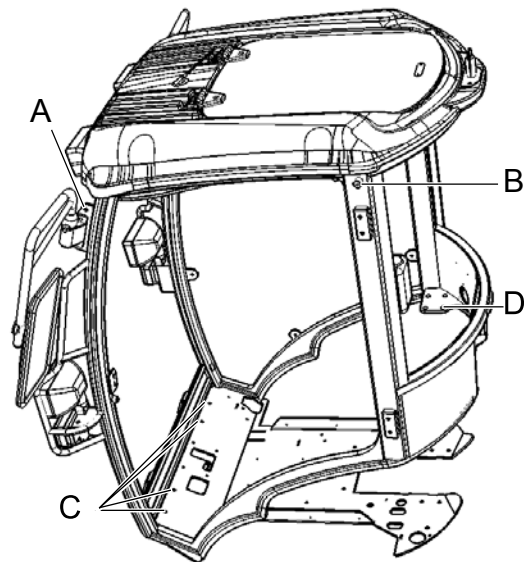

**Note** The machine must not be driven without a cab unless a roll bar has been installed in accordance with the EU directive.

## 2.5 Lubrication

All lubrication points according to the table below must be lubricated after every 50 operating hours as well as after each clean.

Use a grease gun, filled with universal grease. Pump until grease protrudes. The lubrication points are shown in the figures on the following pages.

Object	Lubrication nipples / action	Figure
Lifting fork, turning	1 lubrication nipple	A
Lifting fork, up-down	2 lubrication nipples	B
Lifting cylinder	2 lubrication nipples	C
Control cylinder	2 lubrication nipples	D
Pivot point	3 lubrication nipples	E
Accessories	Also check the grease nipples on the relevant implement	

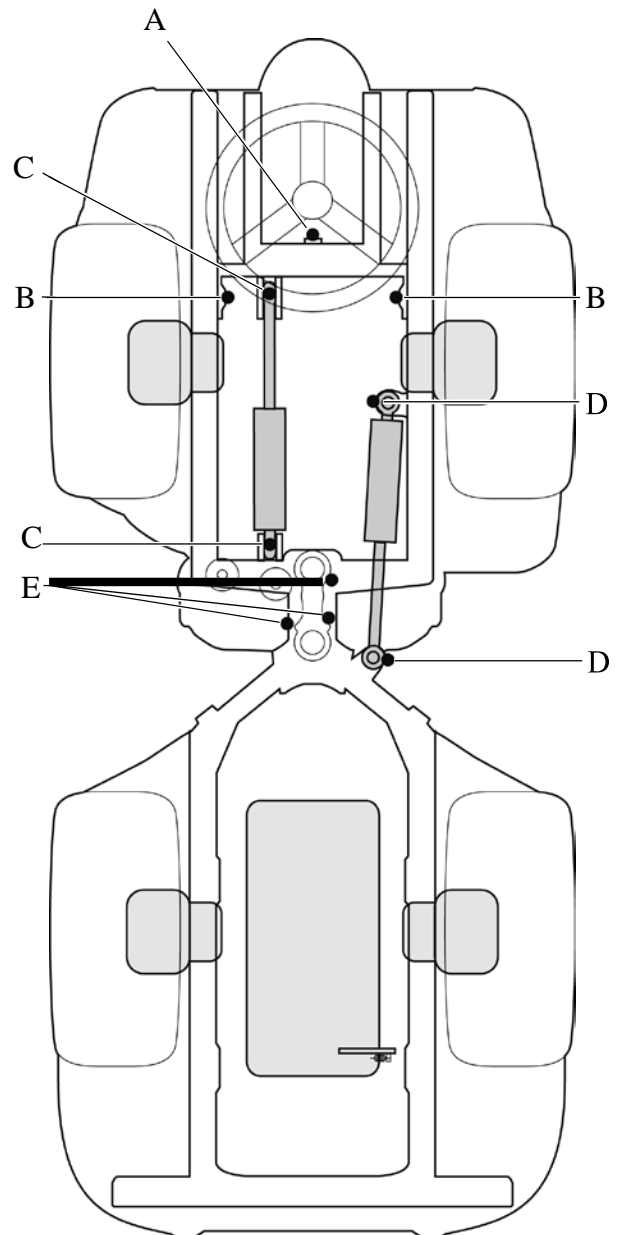

## 3 Steering system

### Contents

<b>3.1 Description .....</b>	<b>32</b>
3.1.1 Removing the power steering servo	32
3.1.2 Installing the power steering servo ..	35
3.1.3 Replacing O rings in the power steering servo .....	35
3.1.4 Replacing O rings in the hydraulic cylinder .....	39

### General description

The machines are equipped with a steering system with a hydraulic servo. A hydraulic cylinder is connected between the front and rear frame. The hydraulic cylinder positions the frames at different angles in relation to each other.

This chapter contains a short description of how the steering works, how repairs are carried out and how wear components of the steering system are adjusted.

## 3.1 Description

The oil flows in the hydraulic steering are described in chapter 4.

### 3.1.1 Removing the power steering servo

#### Machines with cab

1. Remove the cab. See "2.4.5".
2. Remove the duct in front of the steering bracket through which the heating/AC is routed by:
  - A. Unscrew the screws A (12x) that secure the cover for the heating/AC duct.
  - B. Remove the plastic cover that goes up at the steering bracket by removing the four screws. Then remove the plastic protection on each side of the plastic cover and remove the screws inside. Then twist the whole cover off.
  - C. Lift the rubber mat off the floor.
  - D. Then unscrew the screws B (4x) on each side of the duct and the screws C (4x) screwed in under the seat. Then lift off the section of duct routed along the floor.
3. Remove the upper section of the steering bracket by unscrewing the four screws and the knob of the parking brake.
4. Remove the steering bracket protection by unscrewing the two remaining screws.
5. Remove the inner front cover by unscrewing the two remaining screws.

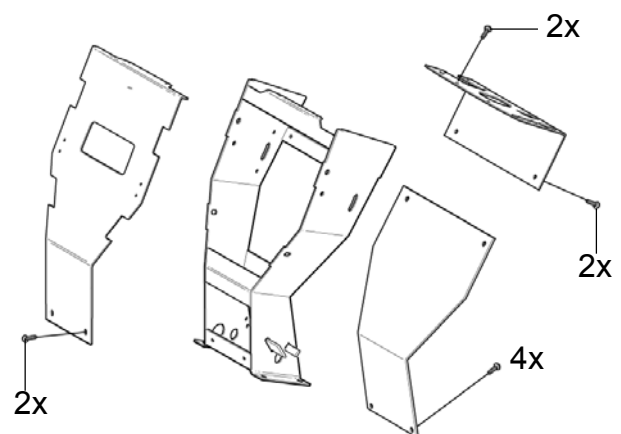
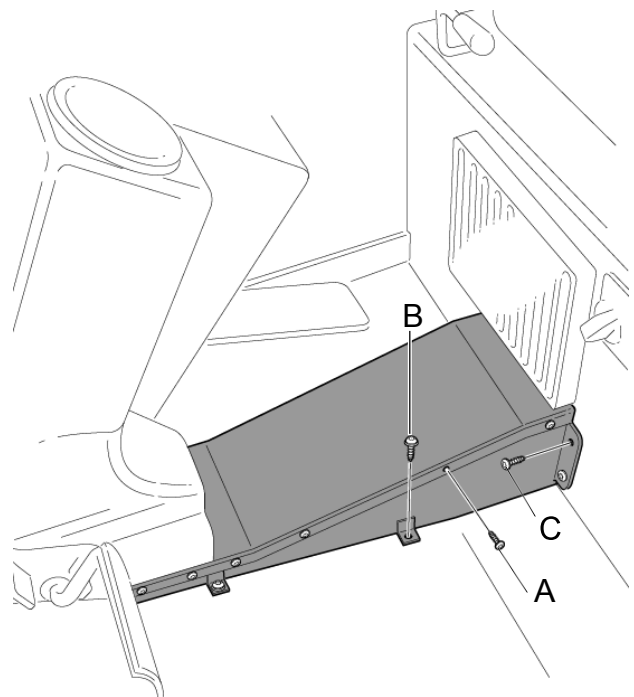

6. Remove the steering wheel by knocking out the locking pin.
7. Mark the position of the five hydraulic hoses that are connected under the power steering servo.  
The letters in the figure are stamped on the bottom, beside the respective sockets.

**Note** Take care to mark the hoses before removal.

8. Slacken off and remove the hoses. Take care to use plugs for both the hose and the unit so that dirt cannot penetrate the system.

**!** No contaminants must enter the hydraulic system. This causes serious damage to components of the systems.

9. Remove the servo by unscrewing the four upper screws A.

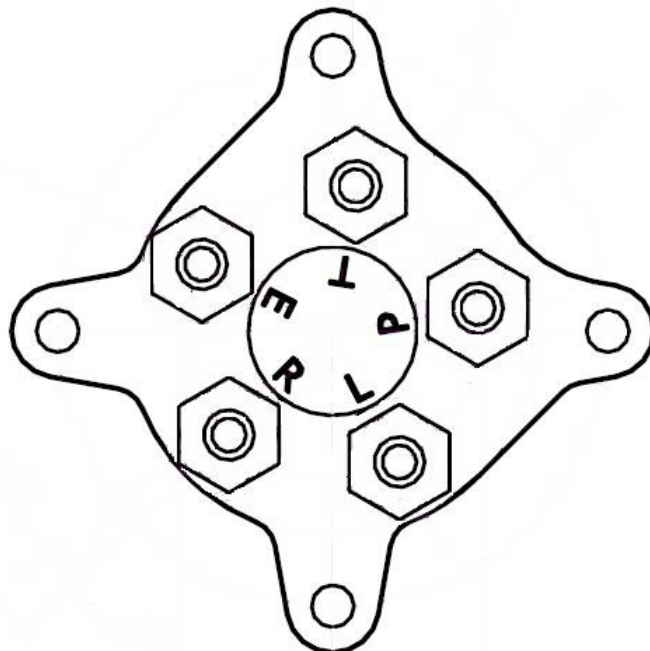
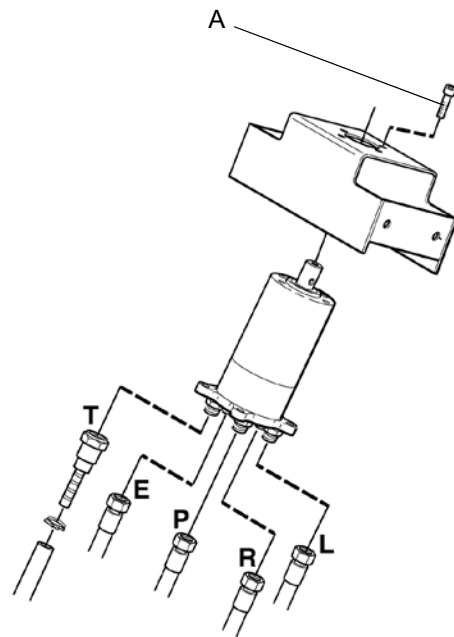

### Machines without cab

1. Remove the lighting bar/reinforcement plate.
2. Remove the cover by removing the 4 screws.
3. Disconnect the electrical cables from the lamps.
4. Remove the upper section of the steering bracket by unscrewing the four screws and the knob of the parking brake.
5. Remove the steering bracket protection by unscrewing the two remaining screws.
6. Remove the inner front cover by unscrewing the two remaining screws.
7. Remove the steering wheel by knocking out the locking pin.
8. Mark the position of the five hydraulic hoses that are connected under the power steering servo.  
The letters in the figure are stamped on the bottom, beside the respective sockets.

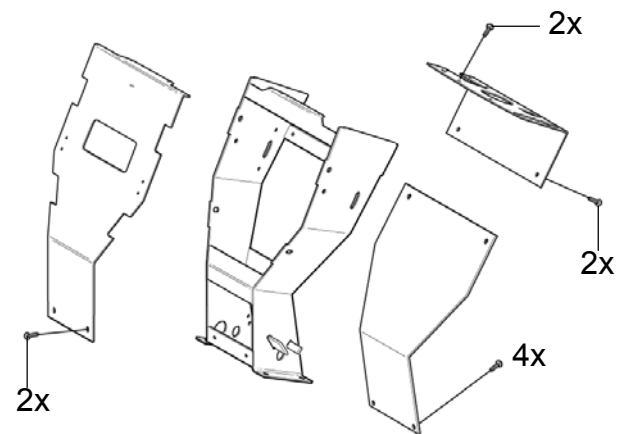
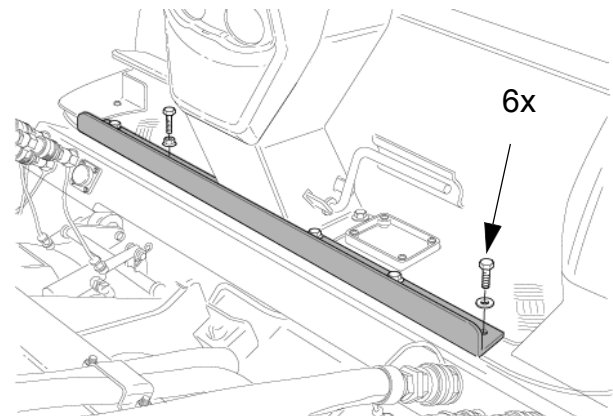

**Note** Take care to mark the hoses before removal.

9. Slacken off and remove the hoses. Take care to use plugs for both the hose and the unit so that dirt cannot penetrate the system.
- ! No contaminants must enter the hydraulic system. This causes serious damage to components of the systems.**
10. Remove the servo by unscrewing the four upper screws A.

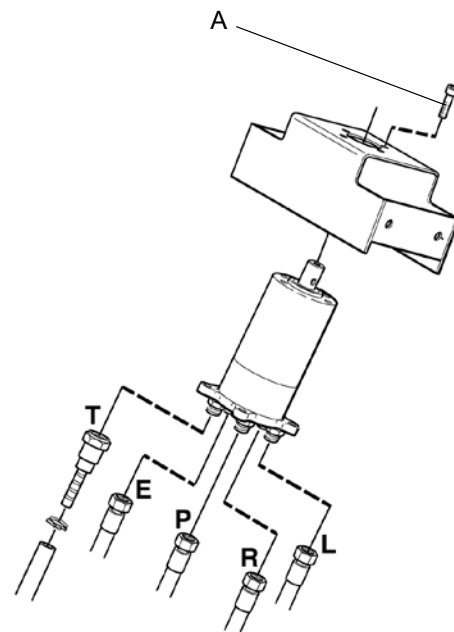



### 3.1.2 Installing the power steering servo

Install the power steering servo in reverse order. Check that the hydraulic hoses were correctly installed according to the markings made during removal.

The system will be automatically bled after several steering wheel movements, carry out a few turns of the steering wheel before driving.

Check after installation that no oil leakage has occurred.

### 3.1.3 Replacing O rings in the power steering servo

#### Remove the power steering servo as follows

Place the unit vertically with shaft C positioned upwards.

1. Over pressure valve R: Remove the plastic plug from the adjustment screw and unscrew it using a 6 mm Allen key.

Remove the spring and valve spool from the housing (A).

2. Choke valves S: Remove the plastic plugs from the adjustment screws and unscrew using a 6 mm Allen key.

Shake out the two springs and two valve balls. Unscrew the valve seats with a 3 mm Allen key.

Place the unit vertically with shaft C positioned downwards.

Before removing make a marking on the housing at port P.

3. Unscrew the screws Q (5x), using a 16mm spanner.

4. Remove the cover P, spacer O, gear wheel N, plate M, O-rings 5 (3x) and propshaft L.
5. Shake out the non-return valve ball J, ball stop I, emergency control ball G, ball stop E (2x), and intake valve balls D (2x).
6. Slide the whole spool out of housing A.
7. Press pin K out of the spool.
8. Carefully press shaft C out of sleeve F.
9. Press out neutral position springs H from shaft C.
10. Shake bearing B from housing A.
11. Remove dust seal 6 and shaft seal 7 using a screw driver.

**Assembly**

1. Before installing, clean all parts carefully and lubricate all parts using hydraulic oil and grease all rubber parts using Vaseline.
2. Install neutral position springs H in shaft C and press them into place (symmetrically extending at both ends).
3. Insert shaft C into sleeve F, turn the parts forwards and backwards to allow the springs to fully extend in the grooves in the sleeve.
4. Install pin K in the spool.
5. Install bearing B and shaft seal 7 on the shaft (see image 1).

Place housing A vertically with the gearwheel side positioned upwards (see image 2),

6. Carefully guide the spool into housing A until the shaft seal reaches its correct position.
7. Place the emergency control ball G, ball stop I and non-reversing valve ball J in port P (see image 2).
8. Place intake valve balls D, ball stop E in port L and port R (see image 2).
9. Install O ring 5 in the housing, ensure that the O ring is lubricated before installation.
10. Place plate M in the housing. Twist it so that the holes correspond (large should match large, small should match small).
11. Install the propshaft L in shaft C and ensure that it aligns with pin K.
12. Install O rings 5 on both sides of gear

wheel N, ensure that the O rings are lubricated before installation.

13. Align gear wheel N and propshaft L so that the teeth in the gear wheel correspond to those on the propshaft (see image 3). Twist the gear wheel so that the five holes correspond to the large holes in the housing.
14. Align spacer O inside the gear wheel N over propshaft L
15. Install the end cover P so that the hole marked "P" corresponds with port P in the housing.
16. Install O rings 1 (5x), in the screws Q (5x).
17. Screw the screws into place Q (5x), with a torque of  $30 \pm 3$  Nm using a 16mm spanner.

Place the unit vertically with shaft C placed upwards.

18. Over pressure valve: install the valve spool, spring, O-ring 2 in the setting screw and tighten using a 6 mm Allen key.
19. Choke valves: Install O-rings 4 in the adjustment plugs and tighten to  $3\div 4$ Nm using a 3 mm Allen key.  
  
Install the balls, valve balls and springs. Install O-rings 2 in the adjustment plugs and tighten using a 6 mm Allen key.
20. Place dust seal 6 down over the axle end and press it into place in the housing.
21. Install the plastic plugs in the over pressure valve and safety valves.

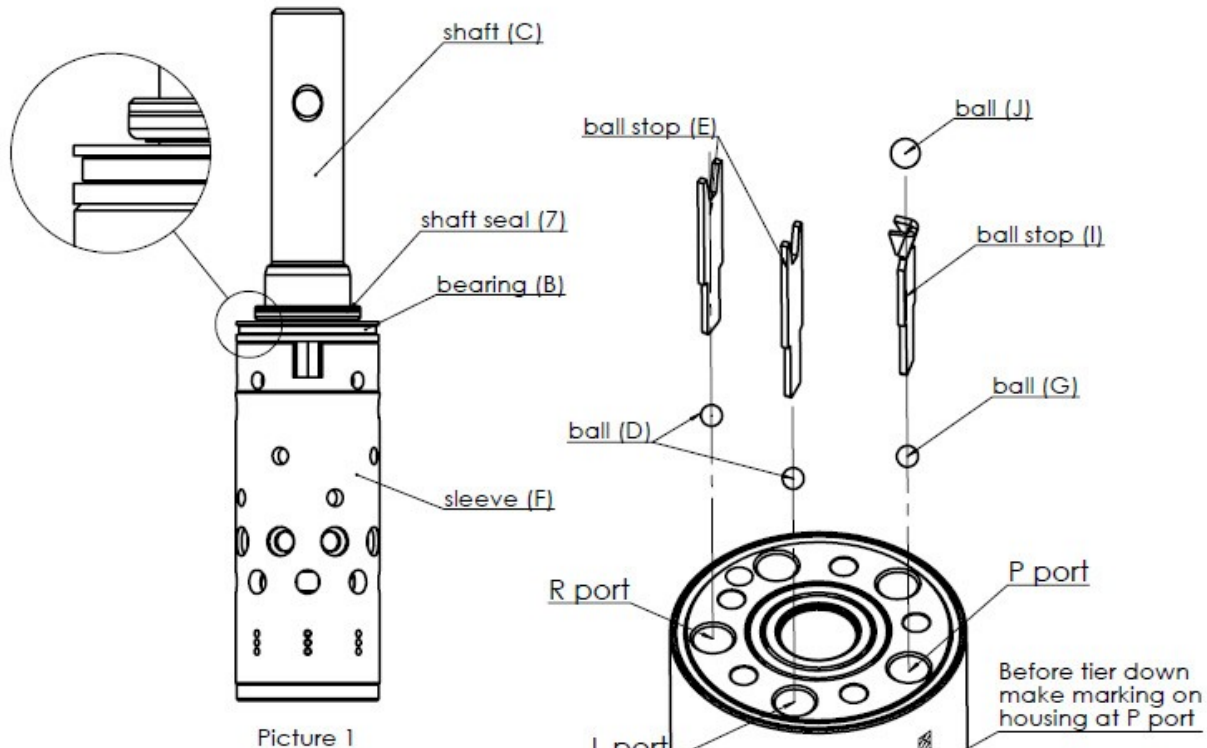

Picture 1

Picture 2

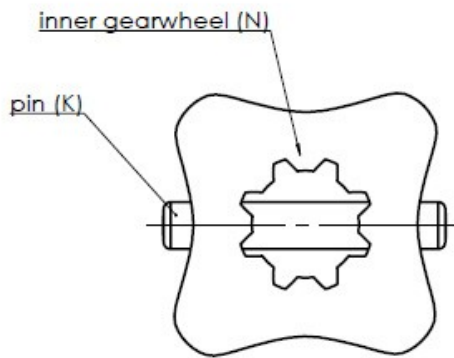

Picture 3

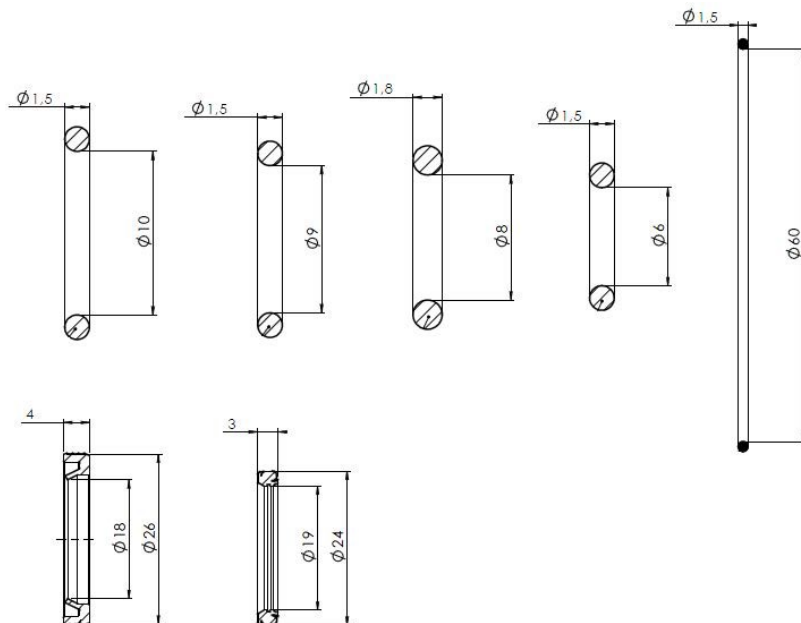
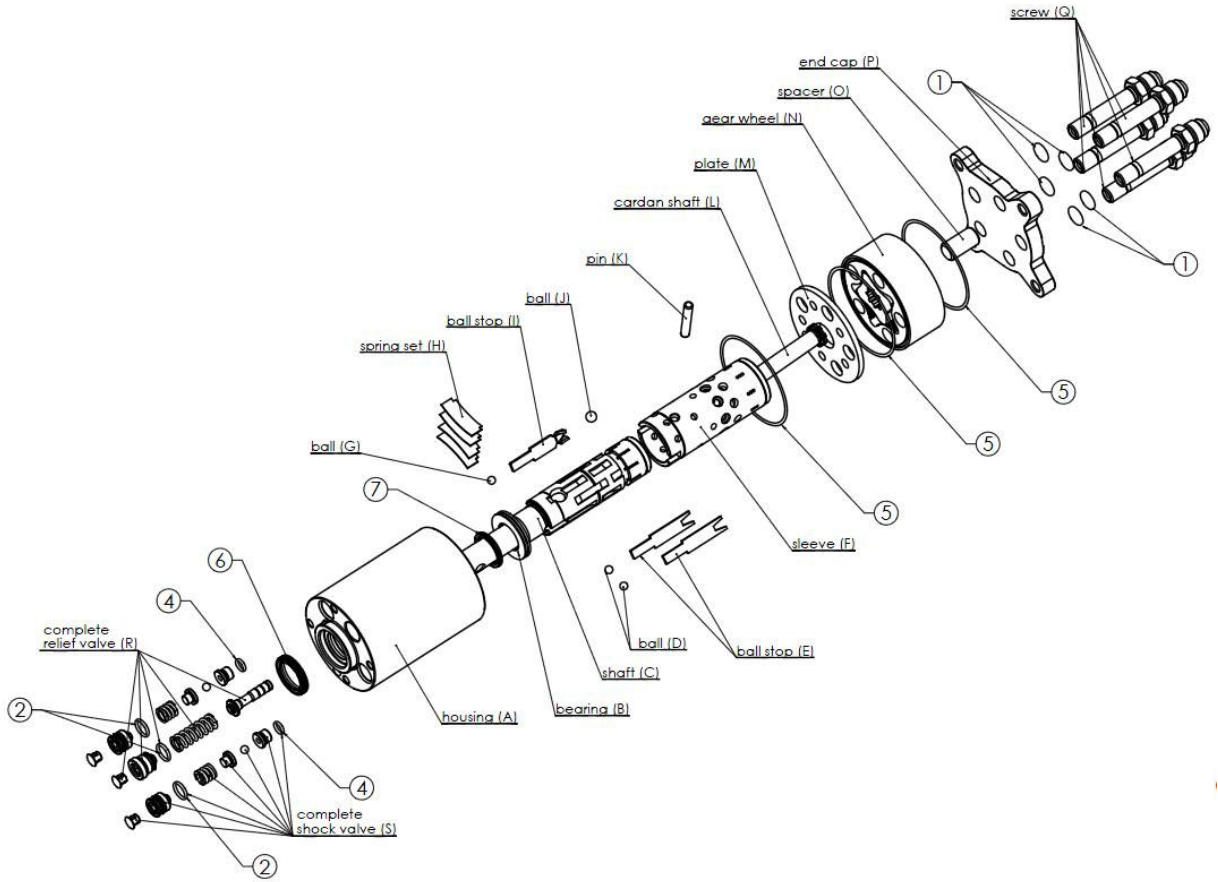

### 3.1.4 Replacing O rings in hydraulic cylinders

#### Lifting cylinder 1134-6801-01

1. Drain the oil through both the connections.
2. Slide in the piston to the end (does not need to be right to the bottom).
3. Remove the circlip using circlip pliers.
4. Carefully tap in the collar approx. 5-10 mm, tap on the steel beside the scraper.
5. Grasp the bar and pull out until it locks.
6. Remove the O ring from the circlip groove.
7. Tap the collar in carefully another 25 mm.
8. Remove the circular locking rings, take care not to mark the pipe (can be difficult to polish out).
9. Grasp the bar and pull out. The piston seal may stick in the circlip groove, if this occurs push the piston in again and pull out with greater force.
10. Look inside the pipe and at the bar, if there are scratches, rust etc. stop and replace the whole cylinder.
11. If the pipe and bar are ok, remove the piston seal, heat the piston and the bar at the end, when the adhesive carbonises there will be a small white cloud.

**Note** Do not heat the sealing surface of the piston.

12. Remove the piston using a wrench.



**Be careful when removing the piston because it is very hot.**

13. Wait until the bar has cooled, then remove the collar.
14. Polish off the adhesive from the threads in the piston before replacing the seal.
15. Remove all seals.

**Note** Sealing surfaces are sensitive to scratches, take care not to use sharp objects or steel.

16. Clean the piston and collar so that they are free of contamination.
17. Install the new seals.

**Note** In this position all surfaces must be visually checked for scratches and other contamination.

After all seal changes the cylinder must be reinstalled.

1. Polish the surface at the lock ring so that there are no sharp edges.
2. Clean the cylinder pipe so that it is free of contamination and other dirt.
3. Polish the piston shaft so that it is free of contamination.
4. Polish off the adhesive from the threads on the shaft. Clean using solvent.
5. Apply a little oil inside the collar.

6. Thread the collar onto the bar (do not forget the circlip and O ring if they have been removed).
7. Apply Loctite 270 to the piston and the threads of the shaft (not so much that it runs).
8. Thread on the piston.
9. Tighten the piston to a torque of 240 Nm, if over-torqued the thread can be stripped and if under-torqued the piston can work loose over time.
10. Apply a little oil around the pipe, on the piston seal and the collar O-ring.
11. Install the piston and collar in the pipe.
12. Install the circular locking rings
13. Pull out the bar to its maximum position.
14. Press in the O ring between the collar and the cylinder pipe.
15. Install the circlip.
16. Ready for use.

**Note** Any guarantees are invalidated if the cylinder has been dismantled.

**Steering cylinder 1135-2808-01**

1. Drain the oil through both the connections.
2. Slide in the piston to the end (does not need to be right to the bottom).
3. Heat the outside of the cylinder pipe (use heat gun for 7-10 min).



**Take care as there is a risk of burn injury.**

4. Unthread the collar and pull out the whole bar.
5. Look inside the pipe and at the bar, if there are scratches, rust etc. stop and replace the whole cylinder.
6. If the pipe and bar are ok, remove the piston seal, heat the piston and the bar at the end, when the adhesive carbonises there will be a small white cloud.

**Note Do not heat the sealing surface of the piston.**

7. Remove the piston using a wrench.



Be careful when removing the piston because it is very hot.

8. Wait until the bar has cooled, then remove the collar.
9. Polish off the adhesive from the threads on the shaft. Clean using solvent.
10. Remove all seals.

**Note Sealing surfaces are sensitive to scratches, take care not to use sharp objects or steel.**

11. Clean the piston and collar so that they are free of contamination.

12. Install the new seals.

**Note In this position all surfaces must be visually checked for scratches and other contamination.**

After all seal changes the cylinder must be reinstalled.

1. Polish off the adhesive from the threads in the pipe. Clean using solvent.
2. Clean the cylinder pipe so that it is free of contamination and other dirt.
3. Polish the piston shaft so that it is free of contamination.
4. Polish off the adhesive from the threads on the shaft. Clean using solvent.
5. Apply a little oil inside the collar.
6. Thread the collar onto the bar.
7. Apply Loctite 270 to the piston and the threads of the shaft (not so much that it runs).
8. Thread on the piston.
9. Tighten the piston to a torque of 240 Nm, if over-torqued the thread can be stripped and if under-torqued the piston can work loose over time.
10. Apply a little oil around the pipe, on the piston seal and the collar O-ring.
11. Install the piston and collar in the pipe.

12. Apply Loctite 243 to the collar threads.

13. Then thread on the collar.

15. Ready for use.

**Note** Any guarantees are invalidated  
if the cylinder has been disman-  
tled.



## 4 Hydraulic system

### Contents

<b>4.1 Safety</b> .....	<b>44</b>	<b>4.7 Repair</b> .....	<b>74</b>
<b>4.2 Configuration</b> .....	<b>44</b>	4.7.1 Changing hydraulic oil, filter .....	74
<b>4.3 Description of drive system</b> .....	<b>45</b>	4.7.2 Level indicator for hydraulic oil .....	75
4.3.1 Physical description .....	45	4.7.3 Changing the oil in the wheel motors .....	75
4.3.2 Function descriptio .....	48	4.7.4 Replacing the belts for the hydraulic pump .....	76
<b>4.4 Description of the steering system</b> .	<b>52</b>	4.7.5 Adjusting drive belts .....	78
4.4.1 Physical description .....	52	4.7.6 Replacing hydraulic pump .....	79
4.4.2 Function description .....	54	4.7.7 Removing the PTO pump .....	80
<b>4.5 Description of hydraulic sockets</b> .....	<b>58</b>	4.7.8 Repair hold height position .....	80
4.5.1 Use of hydraulic sockets .....	58	<b>4.8 Vacuum pump</b> .....	<b>82</b>
4.5.2 Physical description .....	59	<b>4.9 Adjustments</b> .....	<b>83</b>
4.5.3 Function description .....	61	4.9.1 Pressure, PTO drive .....	83
<b>4.6 Description of PTO drive</b> .....	<b>69</b>	<b>4.10 Hydraulic diagram</b> .....	<b>84</b>
4.6.1 Physical description .....	69		
4.6.2 Function description .....	71		

### General description

Titan machines are equipped with hydraulic transmission. The engine drives a hydraulic pump, which pumps oil through the front and rear wheel motors. The machines are manufactured with hydraulically driven PTO.

Front and rear motors are connected in series, which means that the front and rear wheels are forced to turn at the same speed. The design permits a certain degree of differential effect to facilitate cornering.

The machines are also equipped with hydraulic steering, hydraulic implement lift and functions for external hydraulics.

This chapter contains a description and fault tracing of the hydraulic system, and information about how adjustments should be carried out.

## 4.1 Safety



Hydraulic oil under pressure can be very dangerous if any pressurised lines leak. To minimise the risk of personal injury, always wear protective goggles and protective gloves when working with the hydraulic system.



Before starting the engine, place the machine outdoors or connect the exhaust extraction system to the exhaust pipe. Otherwise personnel will be poisoned by the exhaust fumes.



Cleanliness is a condition of all work with the hydraulic system. Foreign particles and contamination will compromise the function and reliability of the system. Always cover openings in hoses, pipes and connections when components are replaced.

## 4.2 Configuration

The machines have hydraulically powered PTO and are equipped with a hydraulic system with three functions as below:

- Drive system
- External hydraulics
- PTO drive

The different systems operate separately, but with the same oil. Each system has its own pump.

The pressure in the drive system depends on the power requirement of the wheels and is limited by the engine power output.

The pressure in the PTO drive system depends on the power requirement and is limited to 220 bar.

The external hydraulics are limited to 125 bar and divided into the following sections:

- Two double action sockets for functions in attached implements.
- One socket at the rear, parallel connected with one of the sockets above (the right hand).
- Double action implement lift.
- Hydraulic steering.

## 4.3 Description of drive system

### 4.3.1 Physical description

#### General

1. Wheel motor, left rear.
2. Wheel motor, right rear.
3. Wheel motor, left front.
4. Wheel motor, right front.
5. Collector block.
6. Charge pump.
7. Main pump.
8. Line main flow (reversing).
9. Line main flow (forward).
10. Line main flow (between right motor).
11. Line main flow (between left motor).

12. By-pass line, front axle.
- 13+14. Non-return valves.
15. By-pass valve.
16. Equalisation channels, integrated in the left wheel motors, front and rear.
17. Line for tramp oil flow.
18. Pressure limiter valve (2.5 bar).

E. Engine.

F. Tank filter.

#### Colour - Pressure

Red means operating pressure to the hydraulic motors.

Green means supply pressure to the main pump. Green line can operate both as the pressure line and the return line, depending on the direction of travel.

Blue is the atmospheric pressure in the reservoir and lines.

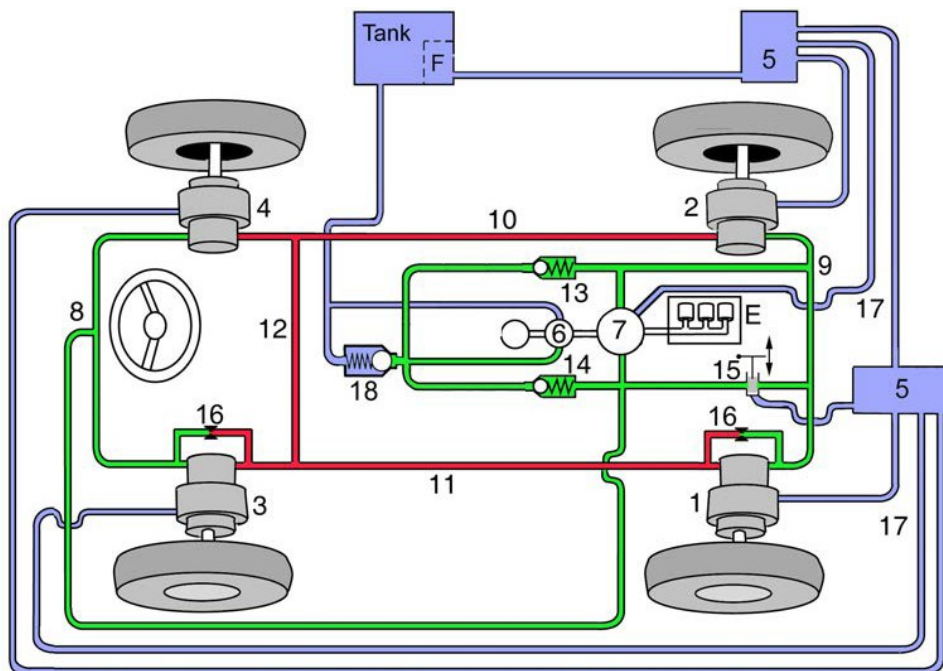

## Wheel motors

Each wheel motor consists of a hydraulic motor and a planetary reduction gear.

The gear ratio in the planetary gear is 12.5:1.

Oil flow through 162 cc per wheel revolution.

Planetary gear is oil lubricated. The oil should be changed according to the table on page 9.

Oil quality: Gear oil 75W-90

Oil volume: 0.08-0.09 l

The physical components of the wheel motors are as follows:

1. Wheel axle.
2. Thread for lifting eye.
3. Hydraulic motor.
4. Main connections.
5. Draining for hydraulic motor.
6. Drain plug for planetary gear.
7. Plug for filling/checking the oil level in the planetary gear.
8. Planetary gear.

### Shoe type

All wheel motors have pistons with skid shoes against the angled disc.

This configuration gives a long service life, because wear to the pistons and disc is reduced.

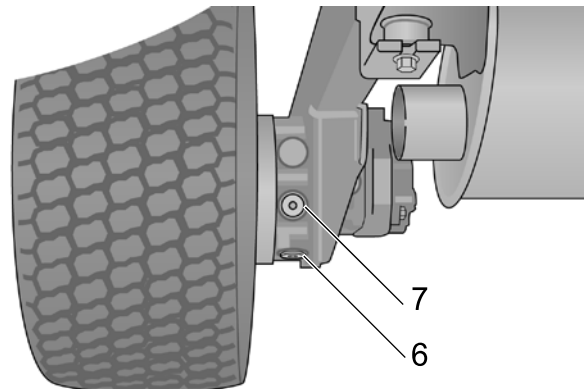
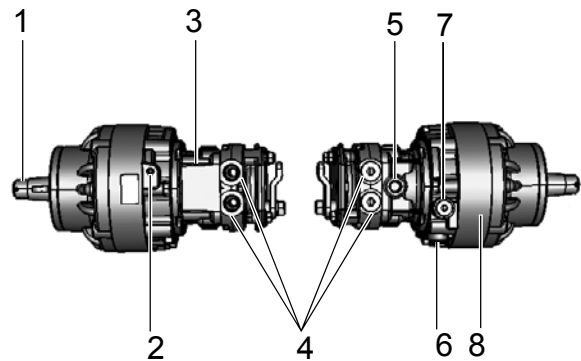

## Hydraulic pumps

Three different hydraulic pumps are integrated to one unit:

- A. Pump for the external hydraulics. This pump is not part of the drive system.
- B. Main pump charge pump.
- C. Drive system main pump.

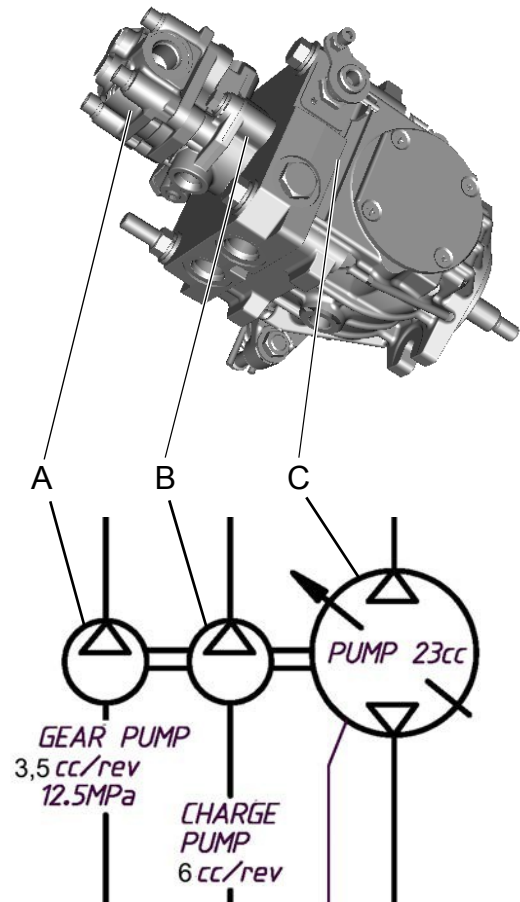

### 4.3.2 Function description

#### Driving forwards

1. Wheel motor, left rear.
2. Wheel motor, right rear.
3. Wheel motor, left front.
4. Wheel motor, right front.
5. Collector block.
6. Charge pump.
7. Main pump.
8. Line main flow (reversing).
9. Line main flow (forward).
10. Line main flow (between right motor).
11. Line main flow (between left motor).
12. By-pass line, front axle.
- 13+14. Non-return valves.
15. By-pass valve.

16. Equalisation channels, integrated in the left wheel motors, front and rear.

17. Line for tramp oil flow.

18. Pressure limiter valve (2.5 bar).

F. Tank filter.

#### Colour - Pressure

- Red means operating pressure to the hydraulic motors.
- Green means supply pressure to the main pump.
- Blue is the atmospheric pressure in the reservoir and lines.

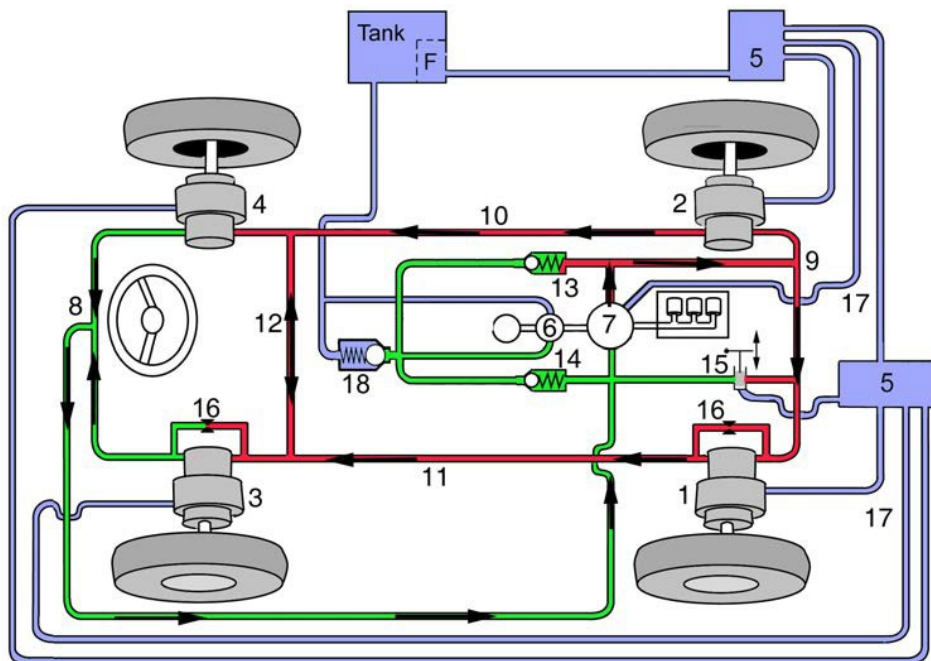

**Driving backwards.**

1. Wheel motor, left rear.
2. Wheel motor, right rear.
3. Wheel motor, left front.
4. Wheel motor, right front.
5. Collector block.
6. Charge pump.
7. Main pump.
8. Line main flow (reversing).
9. Line main flow (forward).
10. Line main flow (between right motor).
11. Line main flow (between left motor).
12. By-pass line, front axle.
- 13+14. Non-return valves.
15. By-pass valve.

16. Equalisation channels, integrated in the left wheel motors, front and rear.

17. Line for tramp oil flow.

18. Pressure limiter valve (2.5 bar).

F. Tank filter.

Colour - Pressure

Red means operating pressure to the hydraulic motors.

Green means supply pressure to the main pump.

Blue is the atmospheric pressure in the reservoir and lines.

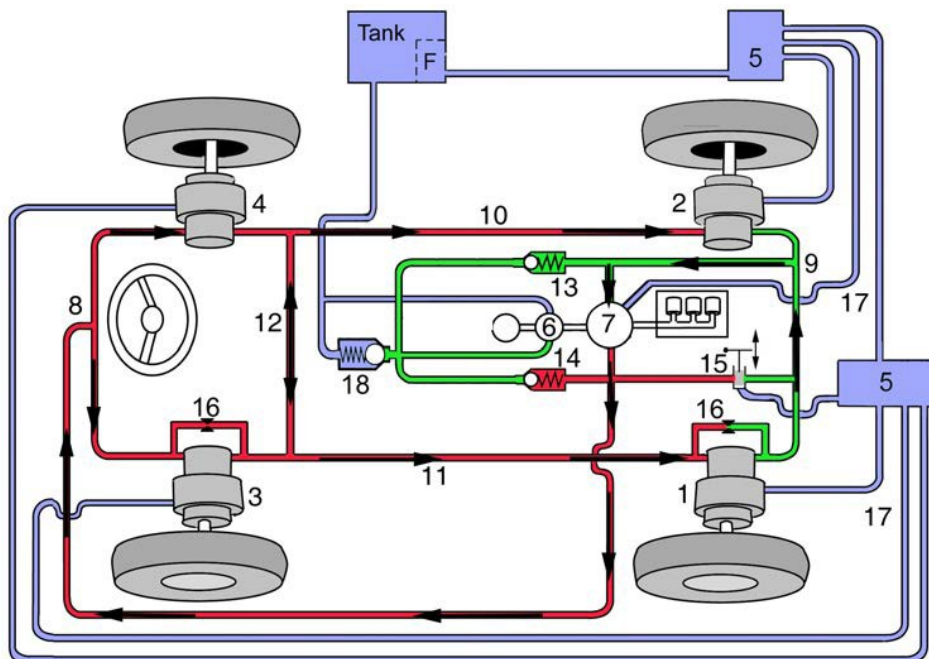

### Description of driving

Charge pump 6 and main pump 7 are integrated to one unit together with the pump for the external hydraulics. The pump unit is mounted on the motor.

The motor drives the pump unit at a constant speed. Charge pump 6 feeds main pump 7 with 2.5 bar via the non-return valves 13 and 14. The pressure is limited with pressure limit valve 18. The pressure limit valve is factory set and cannot be adjusted. The oil that is supplied to the main pump replaces the tramp oil from the wheel motors and from main pump 7. The charge pump ensures a pressure of 2.5 bar at the main pump suction side.

The charge pump sucks oil directly from the tank.

The oil flow and direction of flow through main pump 7 and wheel motors 1, 2, 3 and 4 are controlled by the speed pedal which is mechanically connected to main pump 7. The pressure depends on the power requirement of the wheels and is limited by the engine power output.

### Tramp oil

The wheel motors and the hydraulic pump have a small amount of oil leakage (1-4%), which increases with increased power requirement (increased pressure). The tramp oil is collected in the casing of the unit and is transferred via the collector block in the tramp oil lines 17 back to the tank. Charge pump 6 compensates for the leakage.

### Prioritising driving

The motors on the same axle are connected in parallel. The front wheel motors are connected in series to the rear wheel motors. The rear wheel motors are first in the circuit if driving forwards. This means that because of oil leakage in the rear motors, the machine under normal conditions only drives the rear wheels. When the rear wheels start to spin (rotate 1-4% faster than the front wheels) the front wheels start to drive and wheelspin is avoided.

The driver never notices this, because the machine has drive to all four wheels as necessary.

### Differential

The design described above also has a differential 12, connected between lines 10 and 11. This line makes it possible for all wheels to rotate at different speeds, which is necessary when the steering wheel is turned.

### Equalisation channels

Oil can only pass a wheel motor when the wheel has started to rotate. At very low oil flow for example when starting, the equalisation channel equalises the pressure so that there is more even pressure for all four wheel motors. This is an advantage when one starts with high loads because pressure peaks are avoided and the tractive force is increased because all motors start to drive with the same torque. Equalisation channels ensure that there is a more even pressure curve in normal driving which reduces the stresses on hoses and other components.



### Using the by-pass function

A by-pass valve 15 is connected in parallel with the drivelines. When the by-pass valve is open (inwards), the oil passes the valve instead of the pump. Oil will not flow where the cross is positioned in the figure.

The purpose of the by-pass valve is to remove the resistance in the main pump and permit the oil to circulate in the system when the wheels are turned. The resistance is not zero in the system when the by-pass valve is open. Therefore, it is only permitted to push the machine for short distances with an open by-pass valve, for example on to a trailer.

1. Wheel motor, left rear.
2. Wheel motor, right rear.
3. Wheel motor, left front.
4. Wheel motor, right front.
7. Main pump.
8. Line main flow (reversing).
9. Line main flow (forward).
10. Line main flow (between right motor).
11. Line main flow (between left motor).
12. By-pass line, front axle.
15. By-pass valve.

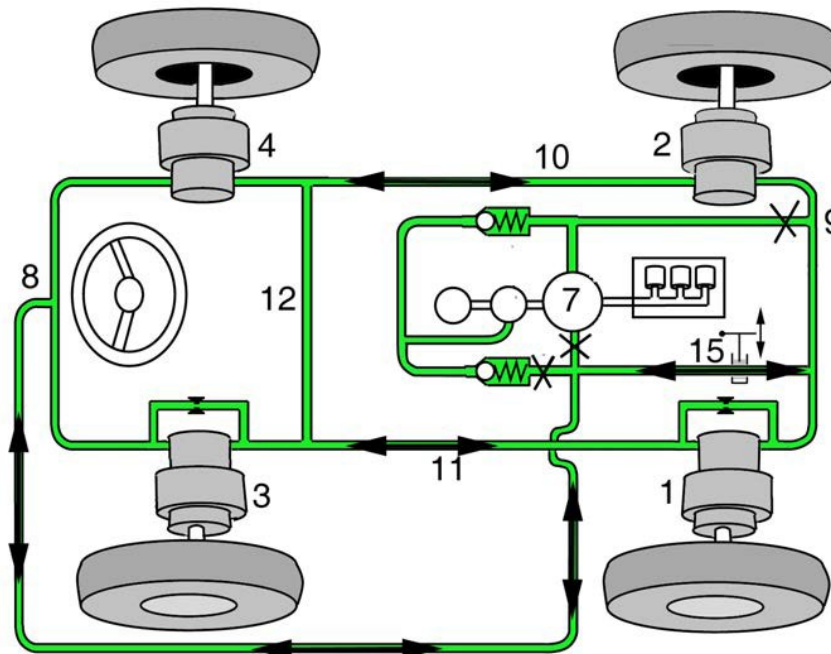

## 4.4 Description of the steering system

### 4.4.1 Physical description

1. Power steering servo containing the following:
  - A. Pressure relief valve
  - B. Safety valves
  - C. Control module
  - D. Oil pump
- Connections on power steering servo
- P. Unregulated input from hydraulic pump for external hydraulics.
- T. Output to the tank for tramp oil and return oil from the passive side of the steering cylinder when steering.
- E. Output to other external hydraulics.
- L. Output to steering cylinder. Pressure when steering to left.
- R. Output to steering cylinder. Pressure when steering to right.

- 2, 3. Pressure lines for transferring steering force.
4. Steering cylinder.
5. Collector block.
6. Pump for external hydraulics, integrated with the drive pumps.
7. Pressure line.
8. Suction line.
9. Tramp oil line and return line.
10. External hydraulics.

#### Colour - Pressure

- Red displays the supply pressure to the power steering servo and external hydraulics.
- Green can be both the pressure line and the return line, depending on the movement.
- Blue displays the atmospheric pressure in the oil reservoir and lines.

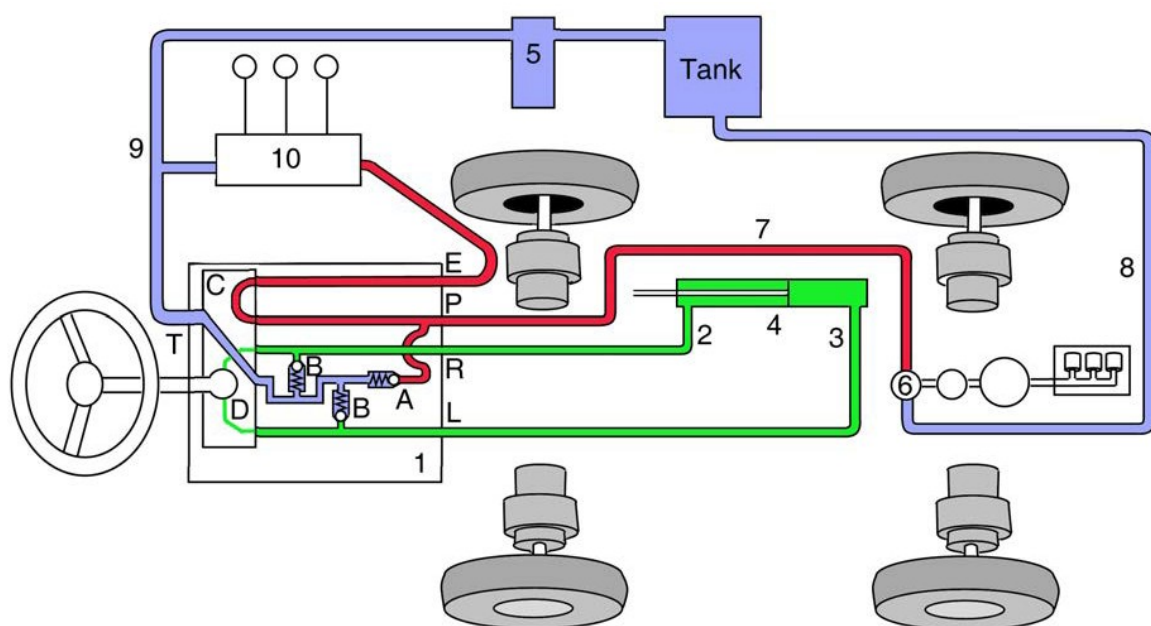

### 1. Power steering servo

The power steering servo is a complete unit. The power steering servo transfers the oil flow to the external hydraulics. The valves in the power steering servo are not adjustable. The power steering servo has 5 hydraulic connections on the underside.

The following are part of the power steering servo:

**A. Pressure relief valve** Pressure relief valve A is set at 125 bar. This means that the pressure in the power steering servo and in the external hydraulics can never exceed 125 bar.

### **B. Safety valves**

The safety valves have the task of reducing the pressure in lines 2 and 3 if sudden obstructions or blockages occur while driving.

### **C. Control module**

The control module has an integrated function that always prioritises the steering in those cases when the steering and the external hydraulics are used at the same time

### **D. Oil pump**

The power steering servo includes an oil pump, that controls the steering cylinder in event of low hydraulic oil pressure. For example if the engine stops, it is still possible to steer the machine. The steering wheel is then harder to turn because there is no power assistance from the hydraulic pump.

4. The steering cylinder is connected between the front and rear frame on the left side of the machine. By operating the cylinder, the frame is placed at the desired angle for steering the machine.
5. The collector block collects all tramp oil and return oil from all hydraulic components for transportation to the tank.

### 4.4.2 Function description

#### The steering is not used

Pump 6 draws oil from the tank and supplies the power steering servo with oil. Because the steering is not used the oil flows through the power steering servo, the control module and the external hydraulics without resistance. If the external hydraulics are used the pressure relief valve A will reduce the pressure to 125 bar.

From the external hydraulics the oil returns to the tank via collector block 5.

1. Power steering servo containing the following:
  - A. Pressure relief valve
  - B. Safety valves
  - C. Control module
  - D. Oil pump

#### Connections on power steering servo

- P. Unregulated input from hydraulic pump for external hydraulics.

T. Output to the tank for tramp oil and return oil from the passive side of the steering cylinder when steering.

E. Output to other external hydraulics.

5. Collector block.
6. Pump for external hydraulics, integrated with the drive pumps.
7. Pressure line.
8. Suction line.
9. Tramp oil line and return line.
10. External hydraulics.

#### Colour - Pressure

 Red displays the supply pressure to the power steering servo and external hydraulics.

 Green can be both the pressure line and the return line, depending on the movement.

 Blue displays the atmospheric pressure in the oil reservoir and lines.

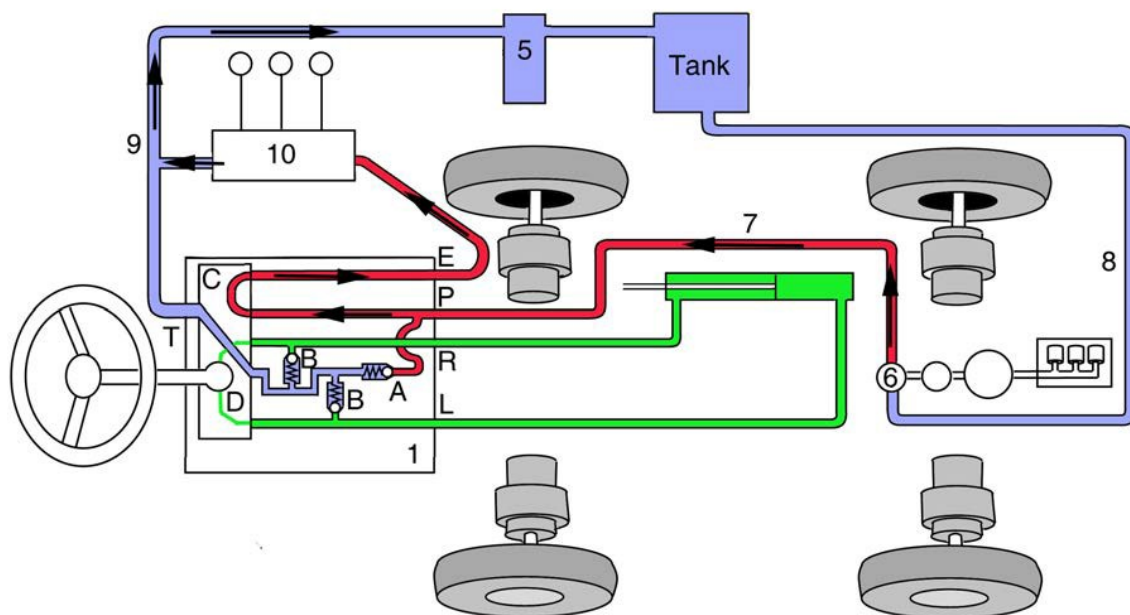

### Steer to the left

1. Power steering servo containing the following:

- A. Pressure relief valve
- B. Safety valves
- C. Control module
- D. Oil pump

#### Connections on power steering servo

- P. Unregulated input from hydraulic pump for external hydraulics.
- T. Output to the tank for tramp oil and return oil from the passive side of the steering cylinder when steering.
- E. Output to other external hydraulics.
- L. Output to steering cylinder. Pressure when steering to left.
- R. Output to steering cylinder. Pressure when steering to right.

2, 3 Pressure lines for transferring steering force.

4. Steering cylinder.

5. Collector block.

6. Pump for external hydraulics, integrated with the drive pumps.

7. Pressure line.

8. Suction line.

9. Tramp oil line and return line.

10. External hydraulics.

#### Colour - Pressure

Red displays the supply pressure to the power steering servo and external hydraulics.

Green can be both the pressure line and the return line, depending on the movement.

Blue displays the atmospheric pressure in the oil reservoir and lines.

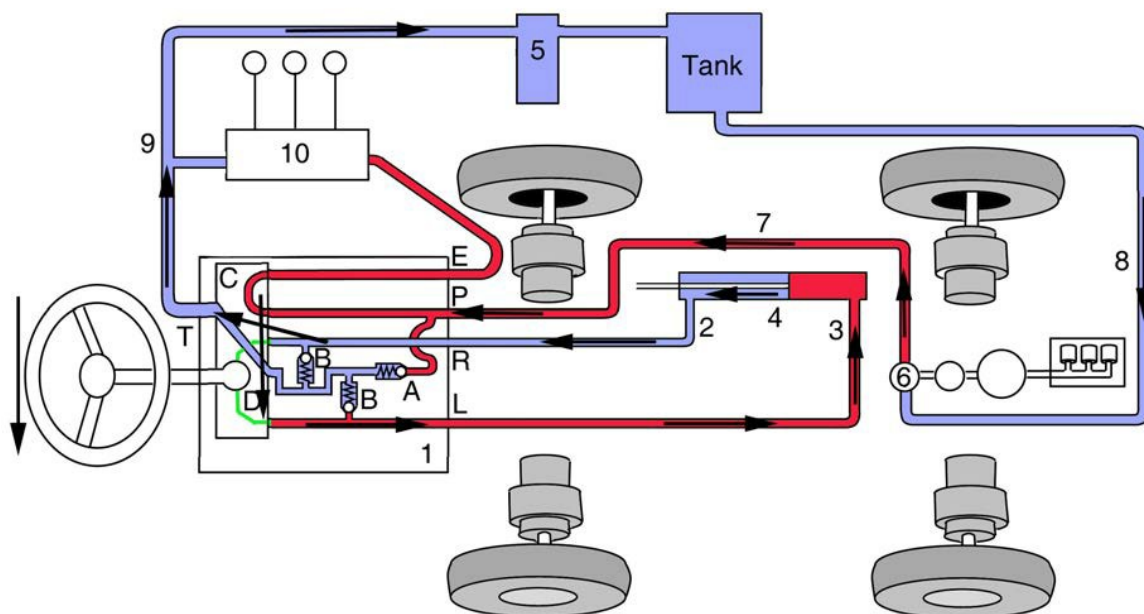

**Steer to the right**

1. Power steering servo containing the following:

- A. Pressure relief valve
- B. Safety valves
- C. Control module
- D. Oil pump

Connections on power steering servo

- P. Unregulated input from hydraulic pump for external hydraulics.
- T. Output to the tank for tramp oil and return oil from the passive side of the steering cylinder when steering.
- E. Output to other external hydraulics.
- L. Output to steering cylinder. Pressure when steering to left.
- R. Output to steering cylinder. Pressure when steering to right.

2, 3 Pressure lines for transferring steering force.

4. Steering cylinder.

5. Collector block.

6. Pump for external hydraulics, integrated with the drive pumps.

7. Pressure line.

8. Suction line.

9. Tramp oil line and return line.

10. External hydraulics.

Colour - Pressure

 Red displays the supply pressure to the power steering servo and external hydraulics.

 Green can be both the pressure line and the return line, depending on the movement.

 Blue displays the atmospheric pressure in the oil reservoir and lines.

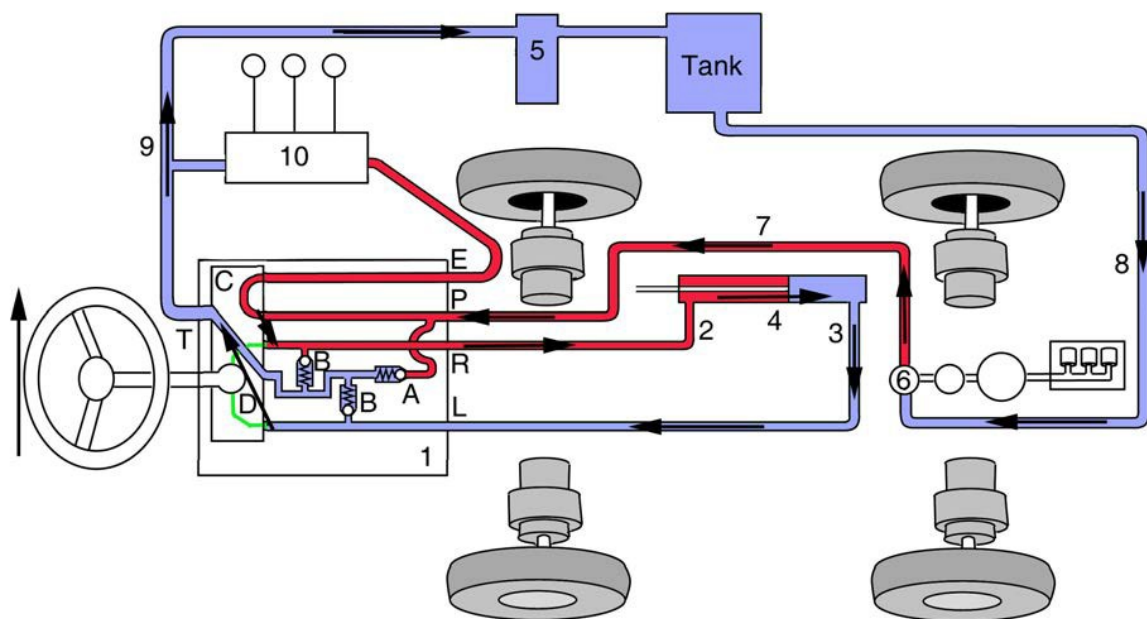



**Steering with the engine off**

1. Power steering servo containing the following:
  - A. Pressure relief valve
  - B. Safety valves
  - C. Control module
  - D. Oil pump
- Connections on power steering servo
  - P. Unregulated input from hydraulic pump for external hydraulics.
  - T. Output to the tank for tramp oil and return oil from the passive side of the steering cylinder when steering.
  - E. Output to other external hydraulics.
  - L. Output to steering cylinder. Pressure when steering to left.
  - R. Output to steering cylinder. Pressure when steering to right.

- 2, 3 Pressure lines for transferring steering force.
4. Steering cylinder.
5. Collector block.
6. Pump for external hydraulics, integrated with the drive pumps.

Colour - Pressure

 Green can be both the pressure line and the return line, depending on the movement.

 Blue displays the atmospheric pressure in the oil reservoir and lines.

Function

Case: No hydraulic pressure (engine stops)

Oil pump D is connected to the steering wheel. The steering wheel rotation is converted to an oil flow. The flow then operates steering cylinder 4 in the desired direction.

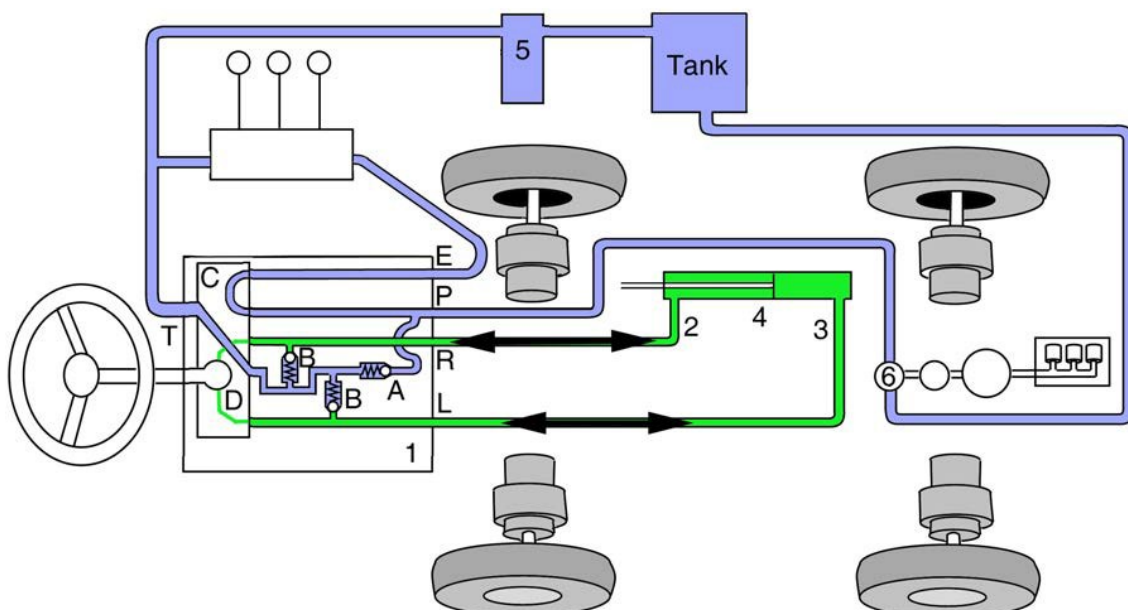



## 4.5 Description of hydraulic sockets

### 4.5.1 Use of hydraulic sockets

#### Implement lift (Ls).

The hydraulic implement lifter only works when the engine is running.

However, it can be lowered to the floating position when the engine is off.



**Never leave the machine with the implement in the transport position. Risk of serious crushing injuries by the implement as it lowers quickly if the control is unintentionally affected.**

The lever has the following four positions:



**Floating position.** Move the lever to its front position, where it locks. The implement is now lowered to its floating position. Also see page 20. In the floating position, the implement always rests against the ground at the same pressure and can follow the contours of the ground. Use the floating position when carrying out work.



**Raising.** Move the lever to the rear position until the implement is in the highest position (transport position). Then release the lever to lock in the transport position.



**Locking in the transport position.** The lever has returned to the neutral position after raising and lowering. The implement is locked in the transport position.



**Lowering.** The implement lowers regardless of its weight. The lowering speed is restricted by limit valve 4. The lowering force is determined by the implement's weight and the hydraulic down force that is applied when lowering.

#### Aux1s and Aux2s

These controls are connected to their respective sockets. The purpose is to control the different movements of the attached implement. For more information see the instructions for use.



### 4.5.2 Physical description

F. Cylinder implement lift.

Ls.Controls for implement lift F.

Aux1. Hydraulic socket front, located to the left.

Aux1s.Control for hydraulic socket Aux1.

Aux2. Hydraulic socket front, located to the right.

Aux2r.Hydraulic socket rear (not available on all models).

Aux2s.Control for hydraulic sockets Aux2 and Aux2r.

T. Tank.

Also see the next page for location on the machine and further description of the components.

1. Pressure relief valve.  
2. Mechanically affected non-return valve.

3. Mechanically affected non-return valve.

4. Limit valve lowering.

5. Collector block.

6. By-pass line.

7. Electric valve, controlled by Aux2fr (not available on all machines).

#### Colour - Pressure

 Red displays the supply pressure to the external hydraulics.

 Green can be both the pressure line and the return line, depending on the implement movement.

 Blue displays the atmospheric pressure in the return lines.

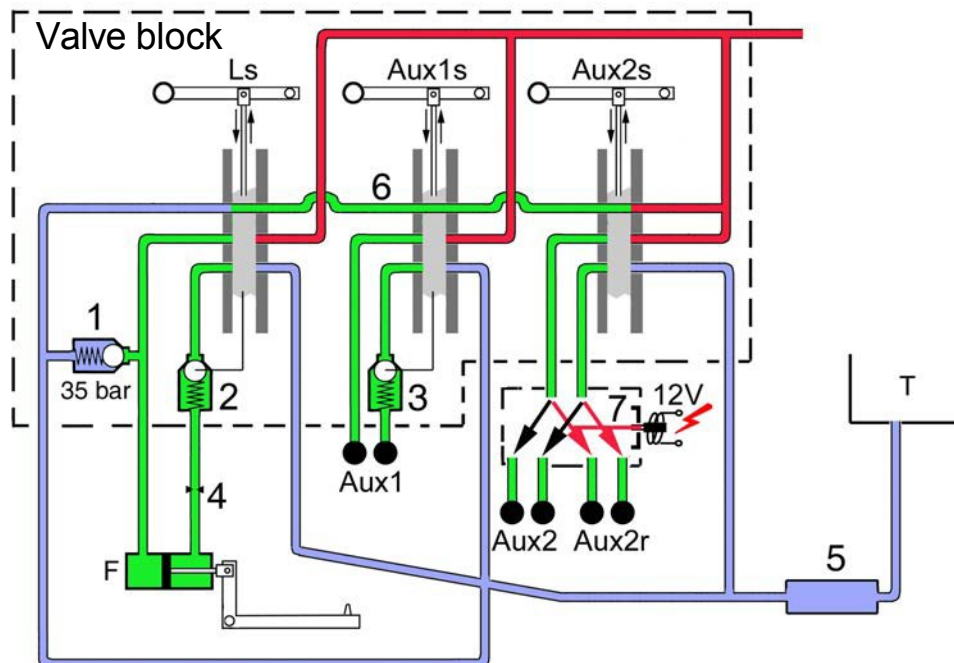

## Location of controls and hydraulic sockets on the machine

Description of components:

### 1. Pressure relief valve

The valve is intended to reduce the pressure when the implement lift is forced down. Otherwise the implement can be damaged and the machine tends to move at the front.

### 2 and 3. Mechanically affected non-return valve

Valves Ls and Aux1s have a little return leakage. To prevent movement under the implements own weight, the oil flow is stopped by these valves. To allow oil flow when the implement is to move in the blocked direction, the valves are mechanically operated so that they open.

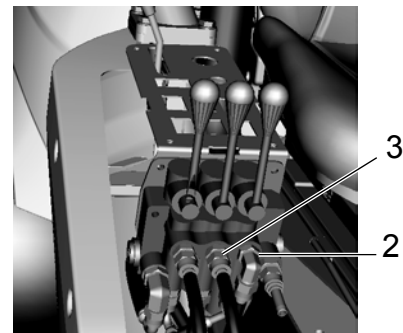

### 4. Limit valve lowering

The valve is intended to reduce the oil flow when the implement is lowered which gives a lower lowering speed.

### 5. Collector block

The collector block collects all tramp oil and return oil for further transportation to the tank.

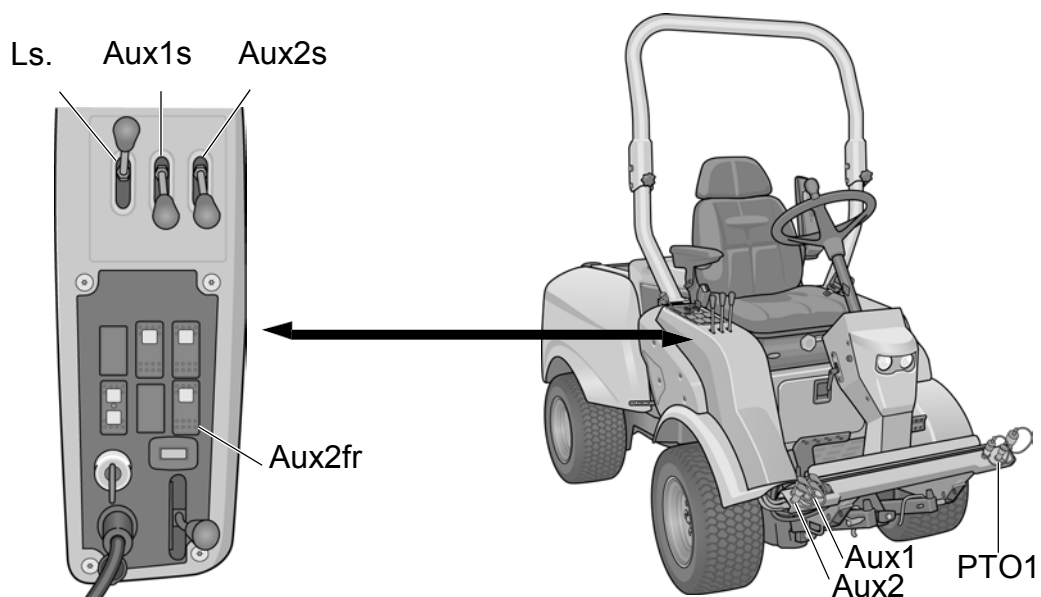

### 4.5.3 Function description

#### External hydraulics not used

Ls. Controls for implement lift F.

Aux1s. Control for hydraulic socket Aux1.

Aux2s. Control for hydraulic socket Aux2 and Aux2r (not on all models).

T. Tank.

5. Collector block.

6. By-pass line.

Oil flows from the control module and through the by-pass line 6.

The oil then flows back to the tank via the collector block.

#### Colour - Pressure



Red displays the supply pressure to the external hydraulics.



Green can be both the pressure line and the return line, depending on the implement movement.



Blue displays the atmospheric pressure in the return lines.

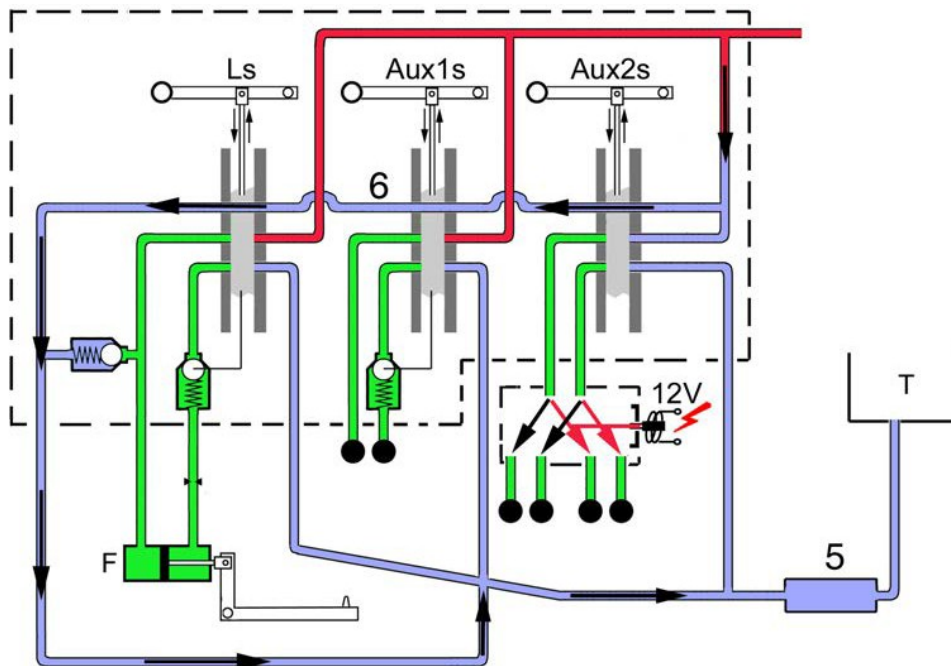

**Raising the implement lift**

F. Implement lift cylinder.

Ls. Controls for implement lift F.

T. Tank.

The by-pass line is blocked in valve Ls.

Oil flows from the control module and through the valve Ls. Valve 2 is opened completely.

The piston in the cylinder F is pressed to the bottom and lift is raised.

The oil on the other side of the piston is pressed back to the tank via the valve Ls and the collector block.

2. Mechanically affected non-return valve.

4. Limit valve lowering.

5. Collector block.

6. By-pass line.

Colour - Pressure

 Red displays the supply pressure to the external hydraulics.

 Green can be both the pressure line and the return line, depending on the implement movement.

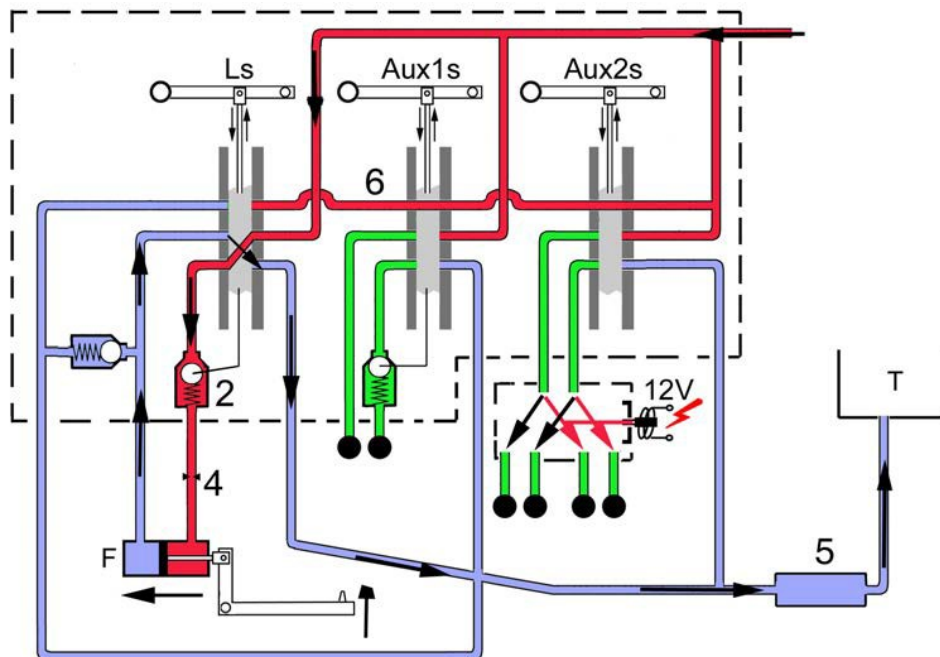

 Blue displays the atmospheric pressure in the return lines.



### Lowering the implement lift

- F. Implement lift cylinder.
- Ls. Controls for implement lift F.
- T. Tank.
- 1. Pressure relief valve
- 2. Mechanically affected non-return valve.
- 4. Limit valve lowering.
- 5. Collector block.
- 6. By-pass line.

#### Colour - Pressure

-  Red displays the supply pressure to the external hydraulics.
-  Green can be both the pressure line and the return line, depending on the implement movement.
-  Blue displays the atmospheric pressure in the return lines.

The by-pass line is blocked in valve Ls.

Oil flows from the control module and through the valve Ls. Valve 1 limits the pressure to 35 bar to protect the implement.

The piston in cylinder F is pressed out with limited force and the lift sinks.

The oil on the other side of the piston is pressed back to the tank via the valves 4, 2 and Ls and the collector block.

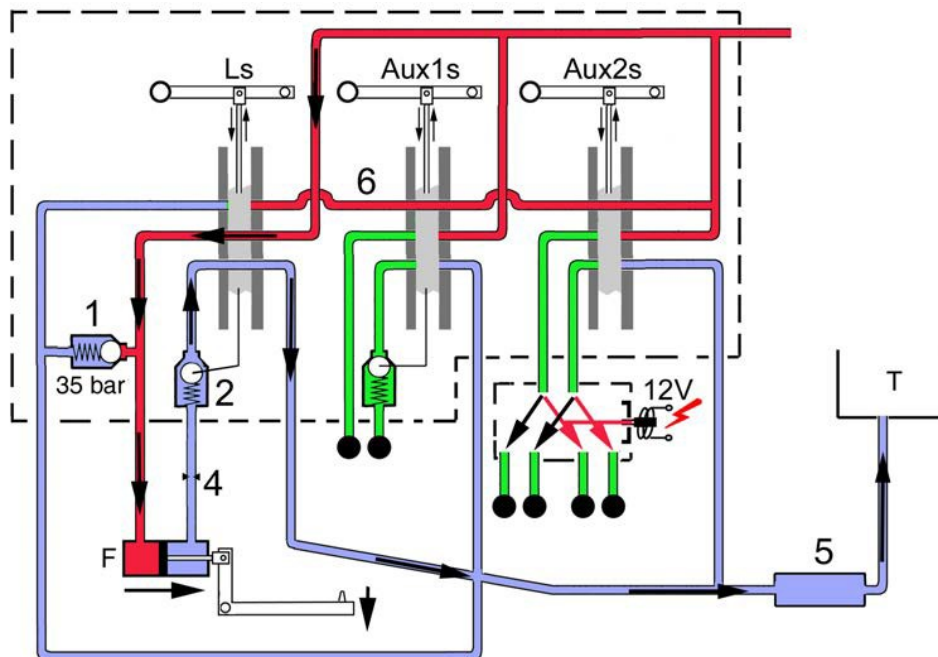

Valve 2 is opened mechanically using a mechanical connection with the piston in Ls. Valve 4 limits the lowering speed.



### Implement lift in floating position

- F. Implement lift cylinder.
- Ls. Controls for implement lift F.
- T. Tank.
- 2. Mechanically affected non-return valve.
- 4. Limit valve lowering.
- 6. By-pass line.

#### Colour - Pressure

-  Red displays the supply pressure to the external hydraulics.
-  Green can be both the pressure line and the return line, depending on the implement movement.
-  Blue displays the atmospheric pressure in the return lines.

Control Ls locks itself automatically in floating position.

Oil flows from the control module and through the by-pass line 6. The oil then flows back to the tank via the collector block.

Valve 2 is opened mechanically using a mechanical connection **with the piston** in Ls.

The oil flows freely through the valves 2, 4 and Ls, between both sides of the piston in lift cylinder F.

Valve 2 is mechanically fully opened by **the slide** in Ls and valve 4 is also open (for desired lowering speed). The limited opening in valve 4 has no significance for the oil flow in floating position.

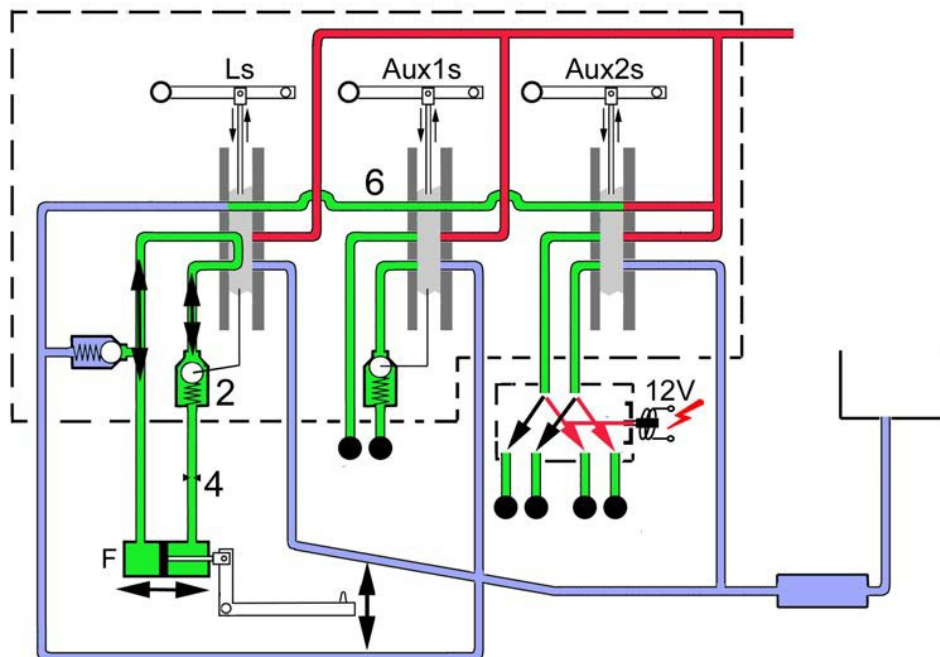

### Hydraulic socket Aux1, direction A

Aux1. Hydraulic socket front, located to the right.

Aux1s The control for hydraulic socket Aux1.

T. Tank.

The by-pass line is blocked in valve Aux1s.

Oil flows from the control module, through the valve Aux1s, socket Aux1, through the implement and executes the movement. Then back to the socket through valve 3, valve Aux1s, collector block 5 and back to the tank. Valve 3 is opened mechanically by Aux1s.

3. Mechanically affected non-return valve.

5. Collector block.

6. By-pass line.

#### Colour - Pressure

 Red displays the supply pressure to the external hydraulics.

 Green can be both the pressure line and the return line, depending on the implement movement.

 Blue displays the atmospheric pressure in the return lines.

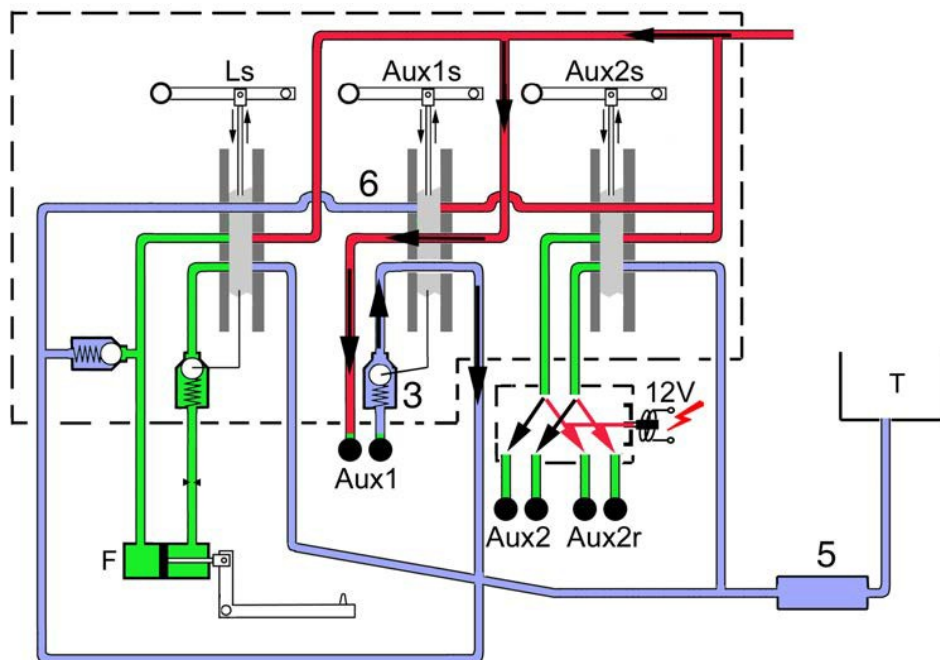

**Hydraulic socket Aux1, direction B**

Aux1. Hydraulic socket front, located to the right.

Aux1s. The control for hydraulic socket Aux1.

T. Tank.

The by-pass line is blocked in valve Aux1s.

Oil flows from the control module, through the valve Aux1s, valve 3, socket Aux1, through the implement and executes the movement. Then back to the socket through valve Aux1s, the collector block 5 and back to the tank.

Valve 3 is opened by the oil pressure.

3. Mechanically affected non-return valve.

5. Collector block.

6. By-pass line.

Colour - Pressure

 Red displays the supply pressure to the external hydraulics.

 Green can be both the pressure line and the return line, depending on the implement movement.

 Blue displays the atmospheric pressure in the return lines.

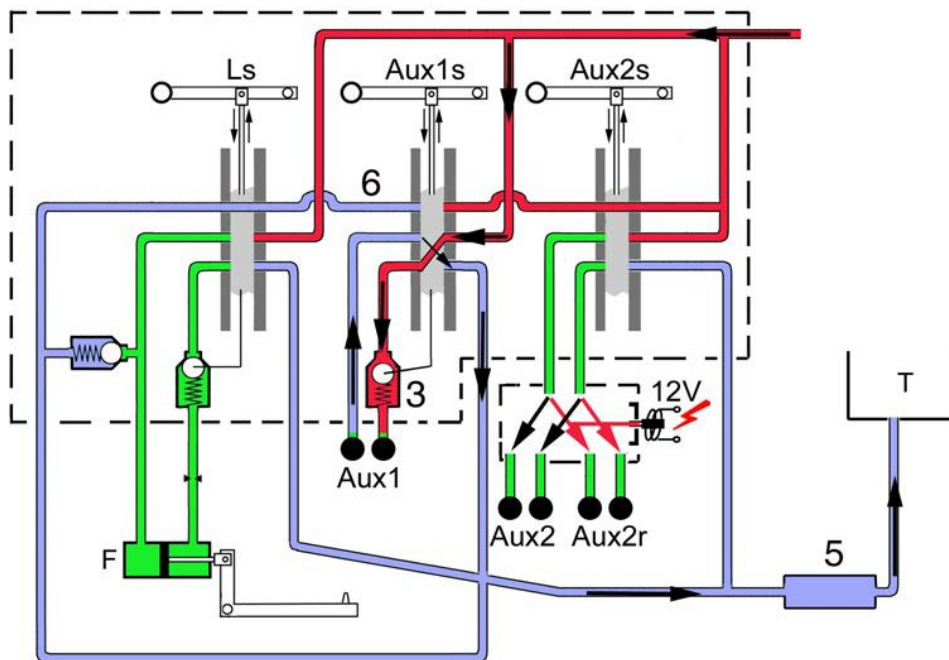



### Hydraulic output Aux2, direction A

Aux2. Hydraulic socket front, right.

Aux2r. Hydraulic socket rear (not available on all models).

Aux2s. Control for hydraulic socket Aux2 and Aux2r (not on all models).

T. Tank.

The by-pass line is blocked in valve Aux2s.

Oil flows from the control module, through the valve Aux2s, through the sockets Aux2/Aux2r, onwards through the implement and executes the movement. Then back to the socket through valve Aux2s, collector block 5 and back to the tank.

Hydraulic sockets Aux2 (front), or Aux2r (rear) are selected by electric valve 7.

This means that only one implement can be controlled, connect to either Aux2 or Aux2r.

5. Collector block.

6. By-pass line.

7. Electric valve, controlled by Aux2fr (not available on all models).

### Colour - Pressure

 Red displays the supply pressure to the external hydraulics.

 Green can be both the pressure line and the return line, depending on the implement movement.

 Blue displays the atmospheric pressure in the return lines.

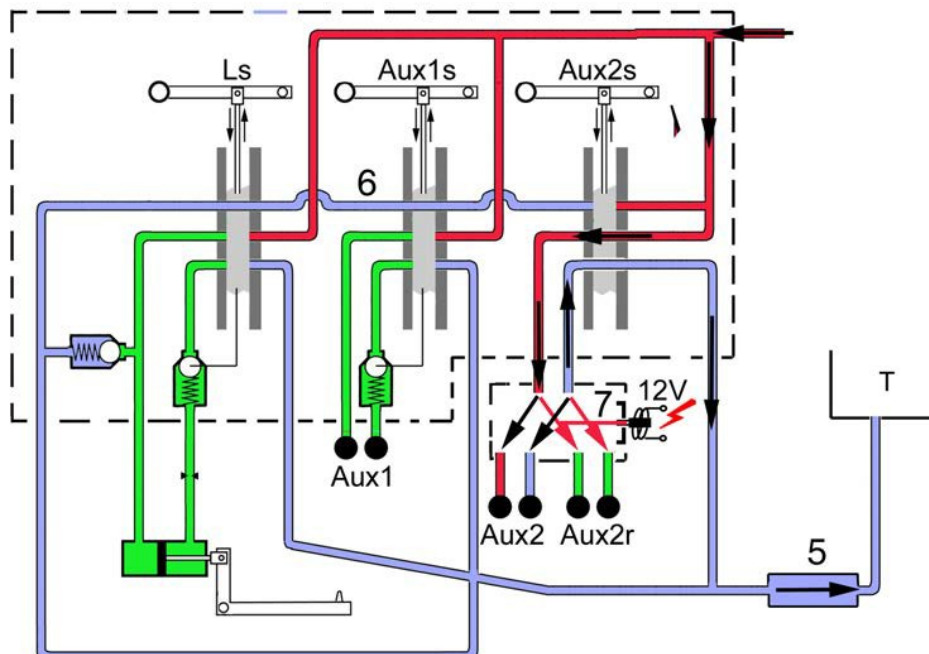

**Hydraulic output Aux2, direction B**

Aux2. Hydraulic socket front, right.

Aux2r. Hydraulic socket rear (not available on all models).

Aux2s. Control for hydraulic socket Aux2 and Aux2r (not on all models).

T. Tank.

The by-pass line is blocked in valve Aux2s.

Oil flows from the control module, through the valve Aux2s, through the sockets Aux2/Aux2r, onwards through the implement and executes the movement. Then back to the socket through valve Aux2s, collector block 5 and back to the tank.

Hydraulic sockets Aux2 (front), or Aux2r (rear) are selected by electric valve 7. This means that only one implement can be controlled, connect to either Aux2 or Aux2r.

5. Collector block.

6. By-pass line.

7. Electric valve, controlled by Aux2fr (not available on all models).

Colour - Pressure

 Red displays the supply pressure to the external hydraulics.

 Green can be both the pressure line and the return line, depending on the implement movement.

 Blue displays the atmospheric pressure in the return lines.

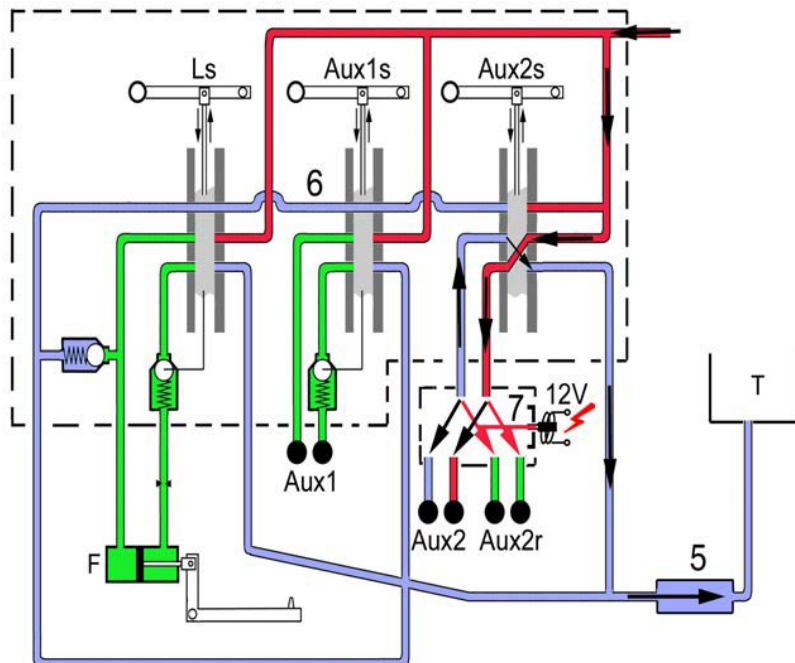



## 4.6 Description of PTO drive

### 4.6.1 Physical description

1. PTO valve, including 2, 3, 4 and 6 below.
  2. Electric solenoid.
  3. Slide inclusive right and left valve.
  4. Pressure limiter valve, 220 bar.
  5. Collector block.
  6. Brake valve.
  7. Oil cooler.
  8. Tramp oil line.
- P. Hydraulic pump.  
 PTO1. Hydraulic socket .  
 PTO1s.Switch.  
 T. Tank.

#### Colour - Pressure

 Red displays the supply pressure to the implement.

 Blue displays the atmospheric pressure in the return lines.

Also see the next page for location on the machine and further description of the components.

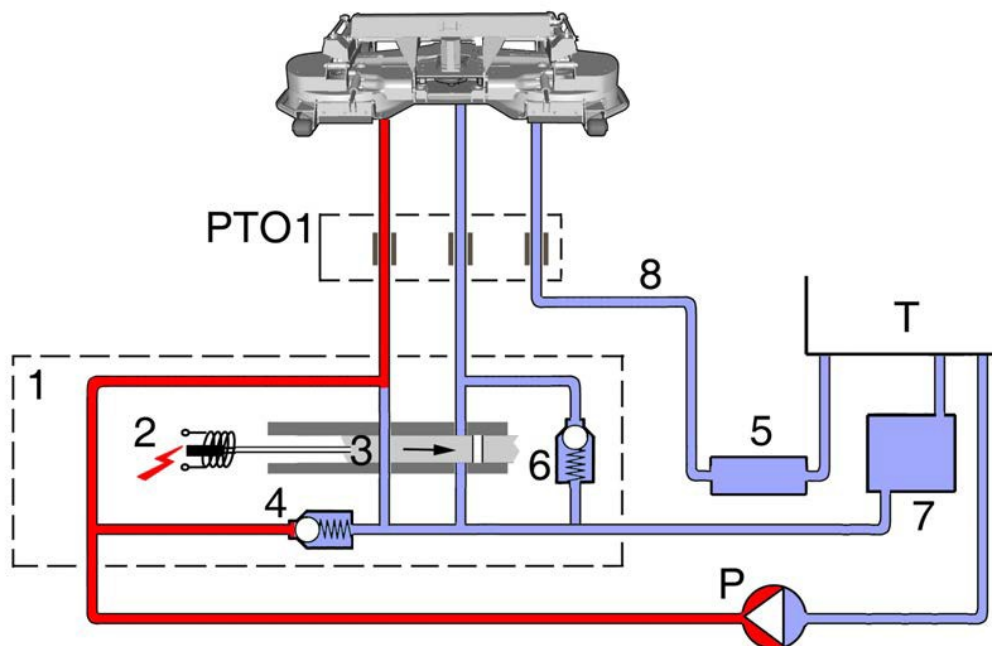

## Location of controls and hydraulic sockets on the machine

For position see page 70.

### 1. PTO valve

The PTO valve is an integrated unit that contains all the properties required to drive the accessory.

### 2. Electric solenoid, 3. Slide

These parts are mechanically connected. The solenoid is affected by the switch PTO1s.

### 4. Pressure limiter valve, 125 bar.

The pressure limiter valve ensures that the pressure never exceeds 125 bar, for example if the rotating parts are blocked.

### 6. Brake valve

The brake valve minimises the implement stop time.

### 7. Radiator

The PTO oil always passes the oil cooler when the engine is running. Because the same oil is used for driving, the hydraulic oil is kept at a suitable temperature level.

### 8. Tramp oil line

The tramp oil line transports all tramp oil from the implement motor back to the tank via the collector block.

### P. Hydraulic pump

The hydraulic pump is directly connected to the engine and works all the time that the engine is running.

### 5. Collector block

The collector block collects all tramp oil and return oil from the hydraulic components and returns it to the tank.

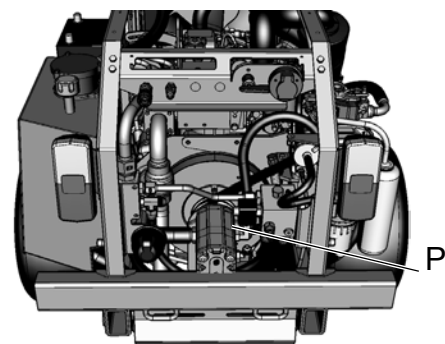
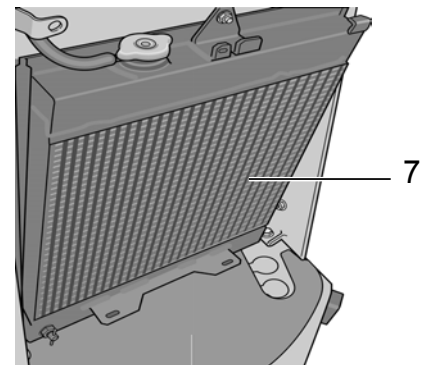
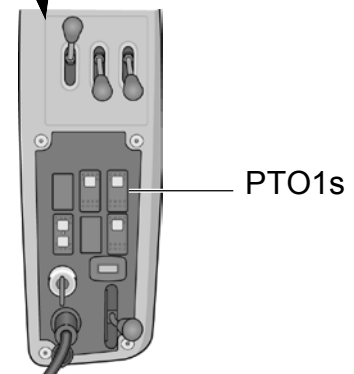
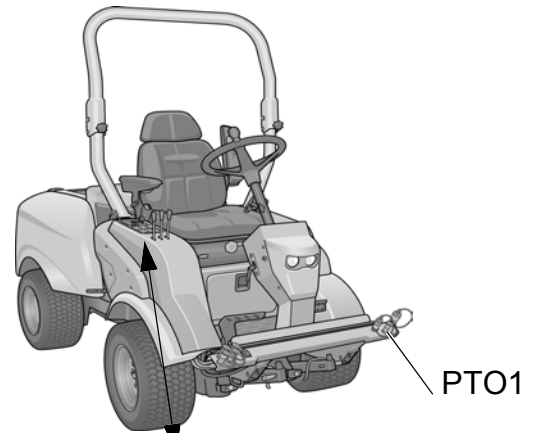



### 4.6.2 Function description

#### No drive engaged

1. PTO valve, including 2, 3, 4 and 6 below.
2. Electric solenoid.
3. Slide inclusive right and left valve.
4. Pressure limiter valve, 220 bar.
5. Collector block.
6. Brake valve, 10 bar.
7. Oil cooler.
8. Tramp oil line.
- P. Hydraulic pump.
- PTO1. Hydraulic socket .
- PTO1s.Switch.
- T. Tank.

#### Colour - Pressure

-  Red displays the supply pressure to the implement.
-  Blue displays the atmospheric pressure in the return lines.

The solenoid is unpowered and the slide is in wait mode. Left valve is open and right valve is closed.

The pump pumps oil, which passes the left valve and returns to the tank via the oil cooler.

Only slight pressure remains in the lines depending on the resistance in the lines and valve.

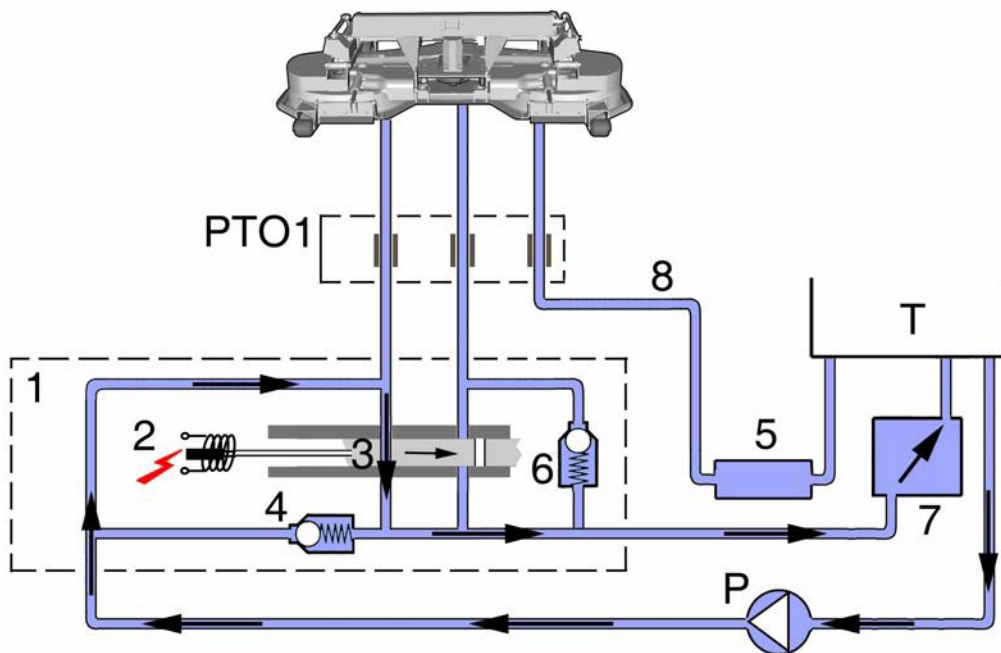

### Driving the implement

1. PTO valve, including 2, 3, 4 and 6 below.
  2. Electric solenoid.
  3. Slide inclusive right and left valve.
  4. Pressure limiter valve, 220 bar.
  5. Collector block.
  6. Brake valve.
  7. Oil cooler.
  8. Tramp oil line.
- P. Hydraulic pump.  
 PTO1. Hydraulic socket .  
 PTO1s.Switch.  
 T. Tank.

### Colour - Pressure

- Red displays the supply pressure to the implement.
- Blue displays the atmospheric pressure in the return lines.

The solenoid is activated using switch PTO1s and the slide closes the left valve and opens the right valve.

The pump pumps oil that is forced through the implement's hydraulic motor because the left valve is closed.

After the engine, the oil passes the right valve and returns to the tank via the oil cooler.

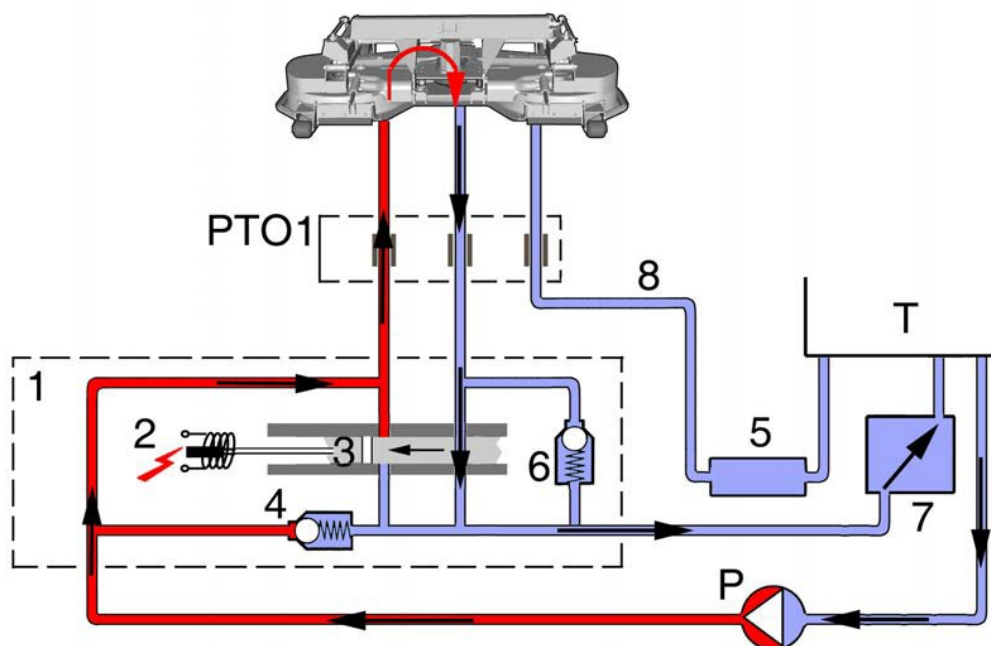

If an abnormal resistance should arise in the pressure line, for example the engine is blocked, the pressure limit valve 4 will open at 220 bar (adjustable) and the oil will return to the tank through that valve.



### Brake function

1. PTO valve, including 2, 3, 4 and 6 below.
  2. Electric solenoid.
  3. Slide inclusive right and left valve.
  4. Pressure limiter valve, 220 bar.
  5. Collector block.
  6. Brake valve.
  7. Oil cooler.
  8. Tramp oil line.
- P. Hydraulic pump.  
 PTO1. Hydraulic socket .  
 PTO1s.Switch.  
 T. Tank.

### Colour - Pressure

-  Red displays the supply pressure to the implement.
-  Blue displays the atmospheric pressure in the return lines.

Switch PTO1 has just switched off and the slide returns to stand-by mode. Left valve is open and right valve is closed.

The pressure in the supply line disappears, but an implement tool continues to rotate due to the kinetic energy and the engine starts to operate as a pump.

To achieve the desired stop time the right valve and brake valve work together. The right valve closes and the oil is forced through the brake valve which is set at 10 bar.

This absorbs the energy from the tool, which stops quickly and softly.

From the brake valve the oil returns to the tank via the oil cooler.

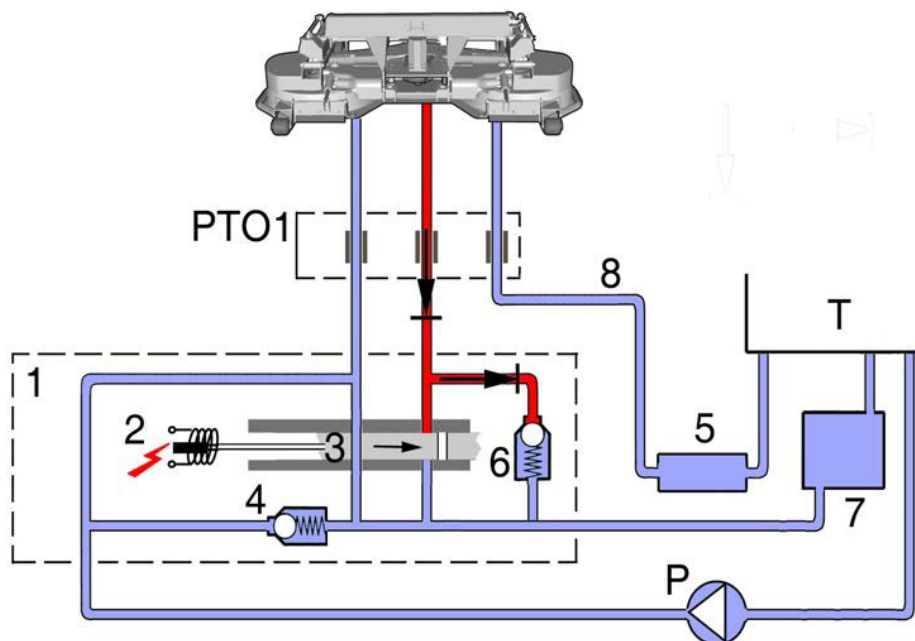

## 4.7 Repair

### 4.7.1 Changing hydraulic oil, filter

**!** Contaminants must not enter the hydraulic system or the fuel system. This causes serious damage to components of the systems.

Change hydraulic oil and filter as follows:

1. Run the machine to operating temperature with varied workload so that the hydraulic oil warms up.
2. Place the machine on a level surface.
3. Clean the area around the filter (A) thoroughly on the upper part of the hydraulic tank and remove the filter bowl and the filter as a unit.

**Note** It is very important that the filter is not taken out of the filter bowl before the filter bowl is removed from the tank to reduce the risk of contamination.

4. Place a container under the oil drain plug (B), remove the plug and allow the oil to run out to the container. The container must have a capacity of 20 litres.
5. Dispose of the oil according to local regulations.
6. Install the oil drain plug. Tighten to 25 Nm.
7. Replace the tank vent valve (C). The valve is unscrewed and the new one is installed in reverse order.
8. Fill with new oil through the 3/8" (D) return connection for the PTO. Use a pump with a 10 micron suction filter.

**Oil type: SAE 10W-30 is recommended. For use in winter a ISO VG46 oil can be used. This oil can also replace SAE 10W-30 if the hydraulic response is slow.**

9. Reinstall the filter with the following components:
  - A1: Filter bowl. Clean the filter bowl carefully before installation.
  - A2: Gasket, check that the gasket is intact.
  - A3: New filter. The filter must always be replaced when changing the oil.
  - A4: Spring.
  - A5: Gasket, check that the gasket is intact.
  - A6: Cap.
10. After filling the oil, start the engine and run the machine for a few minutes and then check for oil leakage.
11. Check the oil level according to "4.7.2".

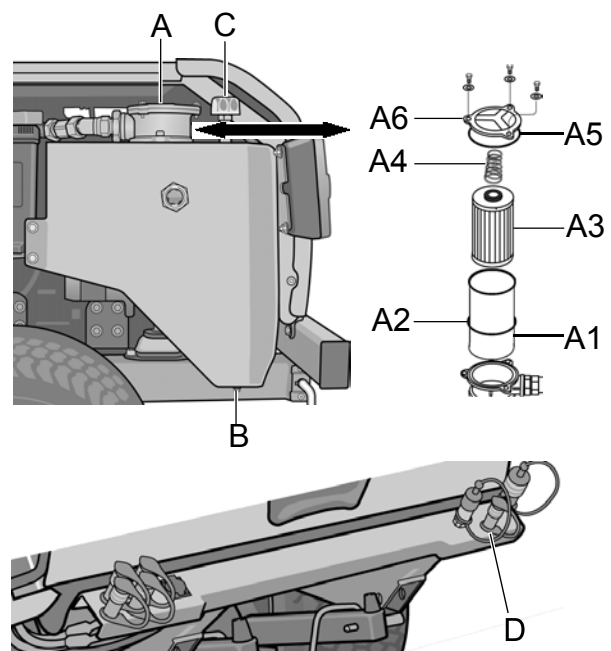



### 4.7.2 Level indicator for hydraulic oil

The oil level must be visible through the transparent glass when the machine is level. If the oil level is too high there is a risk of oil flowing out through the vent valve. If the oil level is too low there is a risk of an increase in the oil temperature and damage to the hydraulic system.

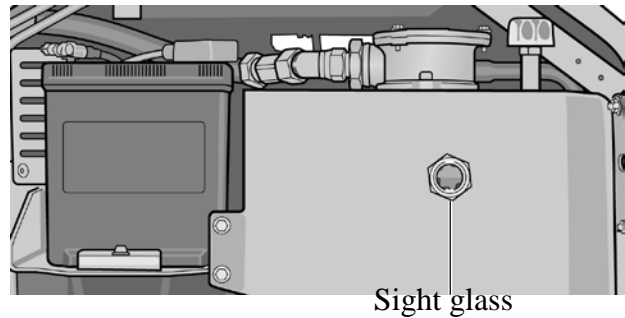

### 4.7.3 Changing the oil in the wheel motors

Change the oil in the gear housing of the wheel motors as follows:

1. Run the machine to operating temperature with varied workload so that the hydraulic oil warms up.
2. Place the machine on a level surface.
3. Clean carefully around the oil plugs A and B.
4. Place a container under the oil drain plug B, remove the plug and allow the oil to run out to the container.
5. Install the filler plug A.
6. Install the oil drain plug.

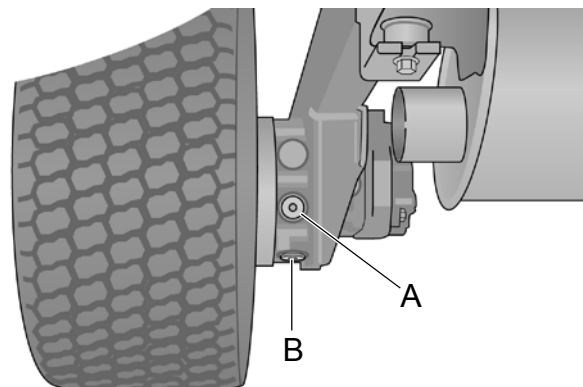

#### **Dispose of the oil according to local regulations.**

7. Fill with new oil via the filler plug.  
Pump in oil using an oil jug. Fill with oil until it reaches the filler plug. 4x0.08-0.09 litre GL4/5 75W-90.
8. Install the filler plug.
9. Tighten the plugs to 30 Nm.

### 4.7.4 Replacing the belts for the hydraulic pump

#### A profile belts

Replace the belts for the hydraulic pump as follows:

1. Remove the rear engine cover. See "2.2.1".
2. Remove the right engine cover. See "2.2.1".
3. Remove the belt cover by slackening off the screws A (3x) that hold the cover in place. Use a 10 mm socket.
4. Unscrew the lower screw B and slide up the tensioner device C to its max position, then tighten the upper screw D for the tensioner device to maintain its new position.
5. Remove the pulley E by locking the starter crown wheel using a flathead screwdriver F at the same time as releasing the shaft nut. Use a 19 mm socket.
6. Remove the fuel filter. Use two 13 mm spanners.
7. Pull off the pulley with the belts still on in order to then remove the belts and remove the pulley completely.

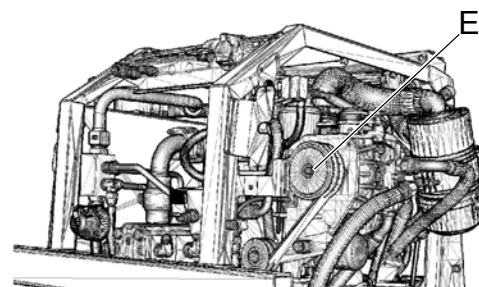
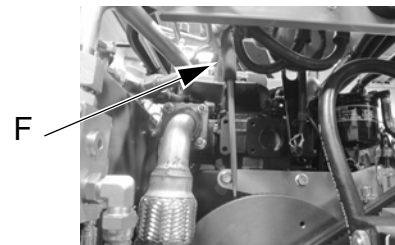
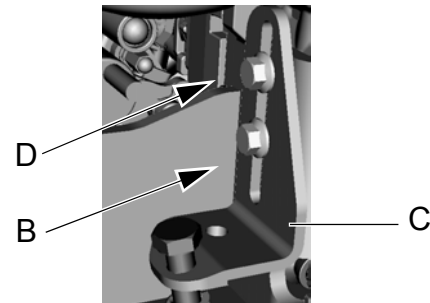
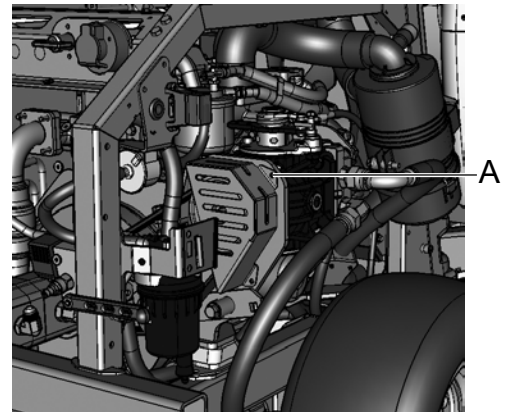

8. Remove the M10 screws G (3x) that hold the carrier plate/pulley to the flywheel as follows:
  - Block the flywheel with a screwdriver or similar and slacken off the screws.
  - Unscrew all the screws half way in a first stage.
  - Then rotate the flywheel one revolution and remove all screws.
9. Pull out the pump with the carrier plate/pulley. Twist off the belts and remove them by threading them out between the carrier plate and the flywheel.

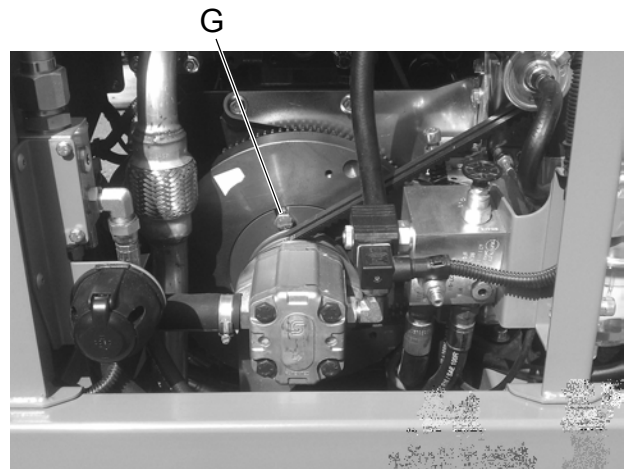

Assemble all parts in the reverse order.

Tension the belts between steps 4 -5 when installing the belts. See "4.3.4".

### **Poly-V belt**

Replace the belt for the hydraulic pump as follows:

1. Remove the rear engine cover. See "2.2.1".
2. Remove the right engine cover. See "2.2.1".
3. Remove the belt cover by slackening off the screws A (3x) that hold the cover in place. Use a 10 mm socket.

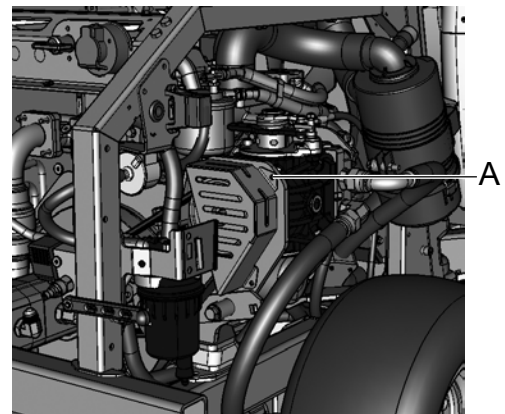

4. Remove the M10 screws G (3x) that hold the carrier plate/pulley to the flywheel as follows:
  - Block the flywheel with a screwdriver or similar and slacken off the screws.
  - Unscrew all the screws half way in a first stage.
  - Then rotate the flywheel one revolution and remove all screws.
5. Use a spanner or similar to push lever arm C down to release the pressure of the tensioner wheel against the belt.
6. Pull out the pump with the carrier plate/pulley. Twist off the belt and remove it by threading it out between the carrier plate and the flywheel.

Assemble all parts in the reverse order. Adjust the belt as necessary, see "4.7.6".

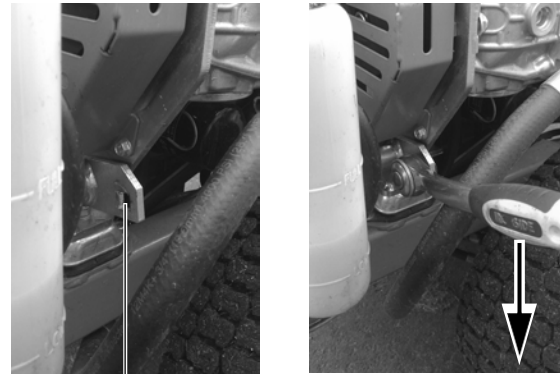
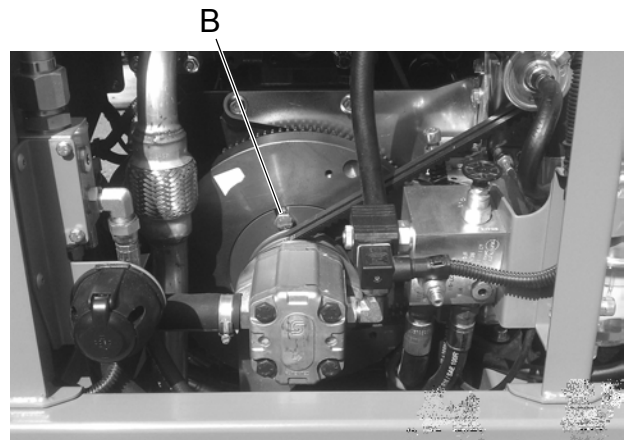

C

#### 4.7.5 Adjusting drive belts (V-belt / Poly-V)

1. Screw an M8-80 screw into A. Slacken off the two screws C.
2. Tighten screw A until the distance between the screw head on "spring" and the plate (distance B) is 12 mm.
3. Tighten the screws C.
4. Remove the M8-80 screw.

The distance must be checked after several hours operation to check that the distance is the same.

- !** Attention!  
 The belts are supplied in kits of two belts that are classed together. Never change just one belt. Never mix belts from different kits.

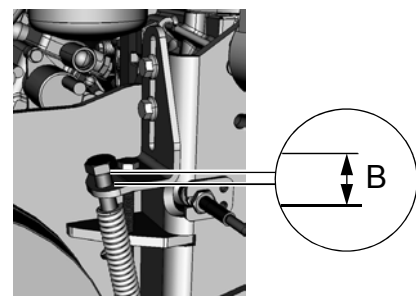
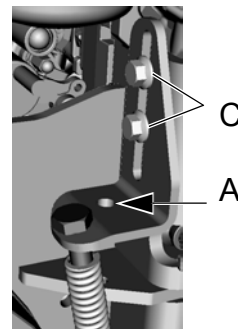

### 4.7.6 Replacing hydraulic pump

**!** No contaminants must enter the hydraulic system. This causes serious damage to components of the systems.

1. Remove the belt cover, belts and pulley. See "4.3.3", point 3-8.
2. Remove the speed control cable. Use a 10 mm spanner and counterhold using an 8mm spanner.
3. Remove the hydraulic pump mounting by unscrewing the two nuts. Use a 19 mm spanner.
4. Install the vacuum pump according to "4.8" or drain the hydraulic oil. We recommend that you use a vacuum pump.
5. Slacken off and disconnect the hydraulic hoses. Before slackening off the hoses they should be marked to ensure that they are reinstalled in the correct position. Make sure that plugs are used for the hoses and the pump.
  - A. Hydraulic hose, front motors
  - B. Hydraulic hose, rear motors
  - C. Hose to external hydraulic tank.
  - D. External hydraulic pressure hose
6. Slacken off and remove the tramp oil hose. Use a 19 mm socket.
7. Remove the pump by removing the 2 screws. Use two 17 mm spanners.

Reinstall the hydraulic pump in reverse order. Make sure that all hoses are in the same position on the new pump.

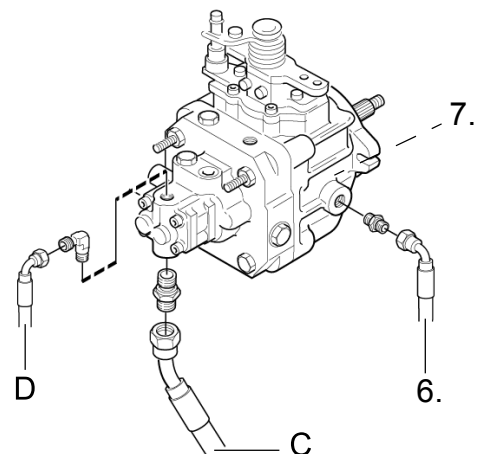
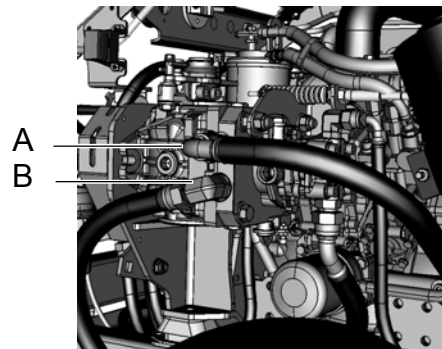
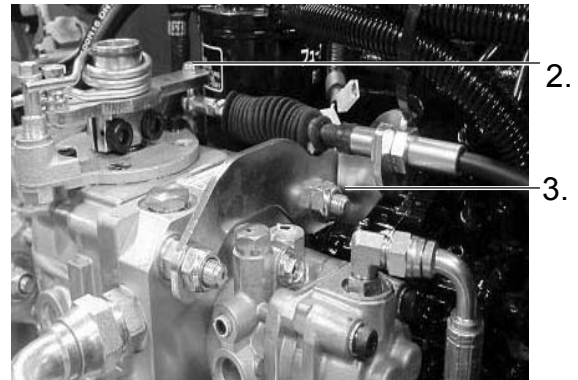

### 4.7.7 Removing the PTO pump

Remove the PTO pump as follows:

1. Install the vacuum pump according to "4.8" or drain the hydraulic oil. Use of a vacuum pump is recommended.
2. Remove the hydraulic hoses A (2x) from the pump.
3. Remove the pump carefully with the carrier plate/pulley. See "4.7.4".
4. Take the pump out from the machine and set the unit up in a vice.
5. Remove the shaft nut and take off the carrier plate/pulley.

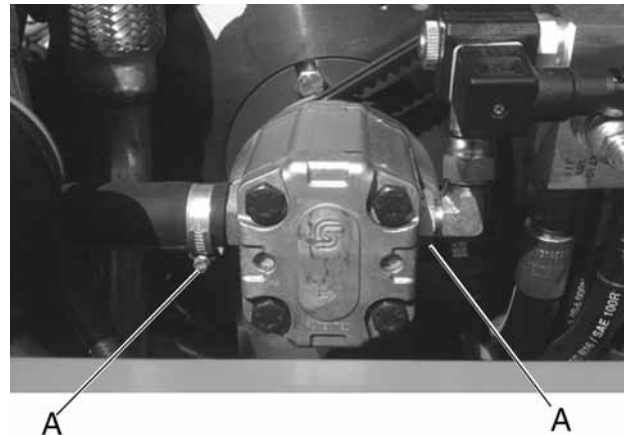

### 4.7.8 Repair hold height position

If the machine reveal a problem to hold the chosen cutting height or the height position of the implement, follow the procedure below by doing in sequence:

1. Check of the cutting deck hydraulic cylinder making sure that it has no internal leakages; valid only for 135DOD and 155DOD Cutting Decks.
2. Check of the hydraulic distributor placed under the right console.

#### Step 1

Make sure that the cutting height adjustment cylinder has not any internal leakage as follow:

- put the cutting height in the most frequently used position. If the cylinder has a leakage, it's most possible that the leakage will appear in this position.
- Disconnect the hydraulic quick connectors (A) on the base unit, from the

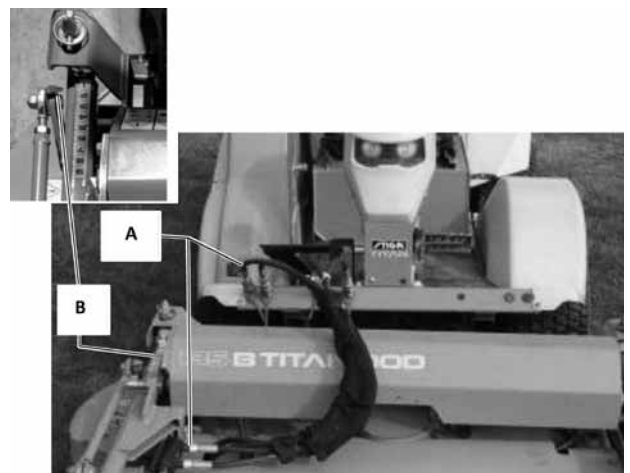

two hoses going to the cutting height cylinder.

- Run the machine on the lawn for 15-20 minutes in normal speed.

If after the run, the arrow (B) on the cutting height indication has changed position, it means that the problem is on the cylinder, it must be replaced. It's possible to swap it by using one of the cylinders for the two flaps.

The flaps can accept a small leakage on the cylinder.

If the arrow has not changed position then the cylinder is ok and step 2 must be followed.

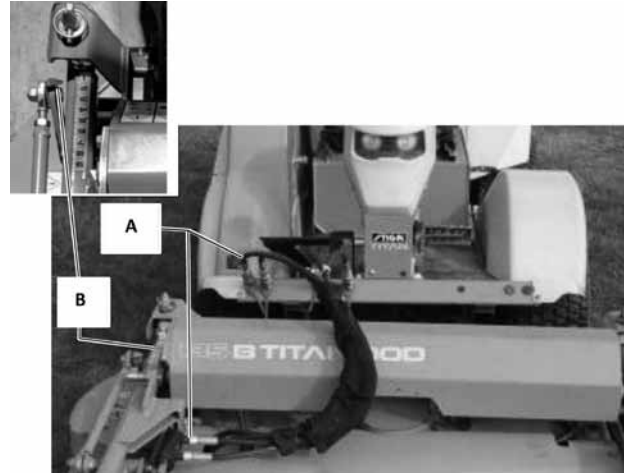

## Step 2

Disassemble the check valve (C) from the hydraulic distributor (D).

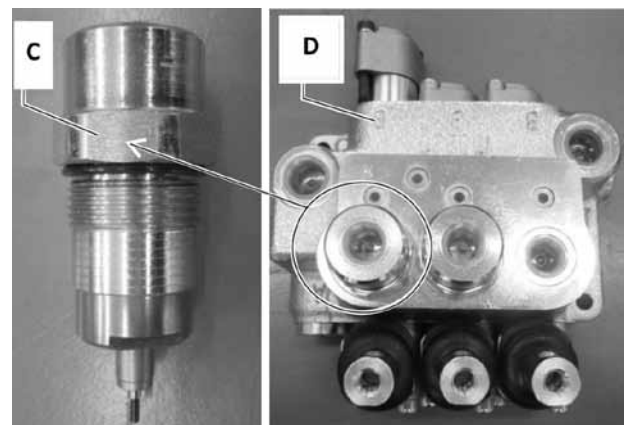

Open the check valve and replace the ball p/n 118830016/0 (E). Make sure the sealing area is well cleaned from debris.

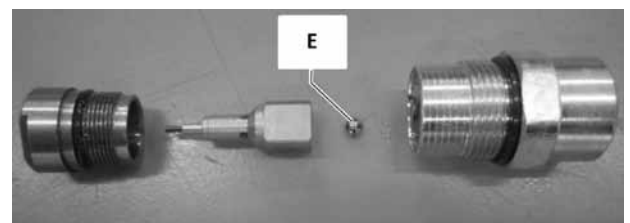

If after the ball replacement the problem is still unsolved, replace the complete check valve p/n 118830017/0 (F)

Pay attention, if the check valve doesn't fit perfectly well, please replace the end part (G) with the old one. To make this operation it's enough unscrew the part above (H).

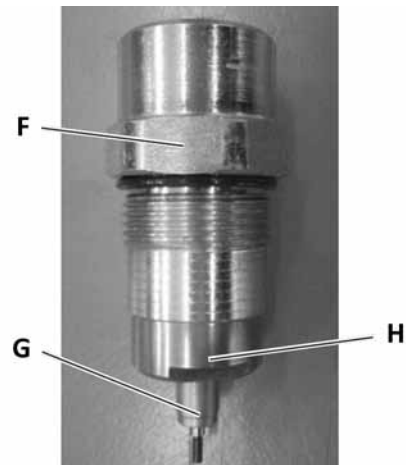

## 4.8 Vacuum pump

The vacuum pump is developed to create a vacuum in the tank to facilitate at service and repairs affecting the hydraulic system.

### Connection

1. Remove the engine covers. See "2.2.1".
2. Unscrew the cap for tank vent valve A.
3. Install the suction hose B from the vacuum pump on the tank vent valve.
4. Connect the positive and negative cable C on the machine battery D.
5. Adjust the vacuum using knob E. The vacuum must be between 0.2 -0.4 bar.
6. Switch on pump F.

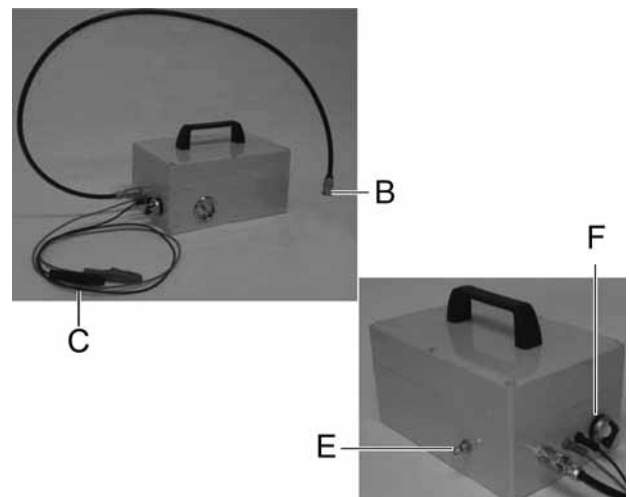
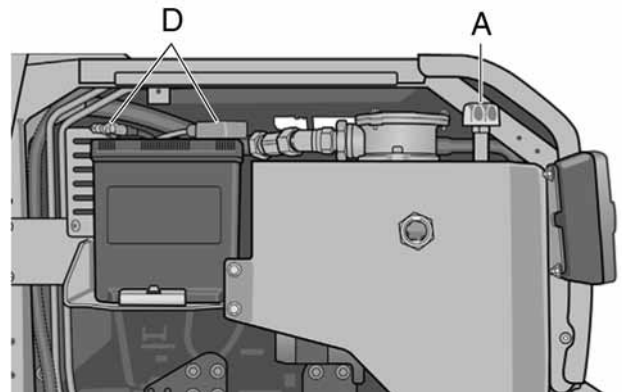



## 4.9 Adjustments

### 4.9.1 Pressure, PTO drive

The PTO drive has two adjustable pressures:

- Max pressure, factory set to 220 bar.
- Brake pressure, factory set to 10 bar.

A. Adjusting brake pressure.

B. Adjusting max pressure.

C. MT1, measurement output for brake pressure.

D. MP, measurement output for max pressure.

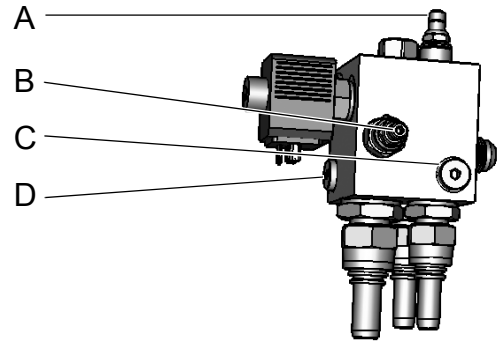

#### Adjusting max pressure

1. Connect a pressure gauge to measurement output MP.
2. Start the engine and activate the PTO without having any accessories connected.
3. Adjust the pressure using valve B and read off the pressure on the pressure gauge.

#### Adjusting brake pressure

1. Connect a pressure gauge to measurement output MT1.
2. Attach a cutting deck, start the engine and activate the PTO.
3. Switch off the drive and read off the brake pressure on the pressure gauge.
4. Adjust valve A and repeat the procedure until the brake pressure and stop time have reached the desired level.

**Note** The brake pressure must not exceed 35 bar.

The stop time must not exceed 7 seconds.

The pressure must not exceed 220 bar, higher pressure creates a danger of damaging other components.

## 4.10 Hydraulic diagram

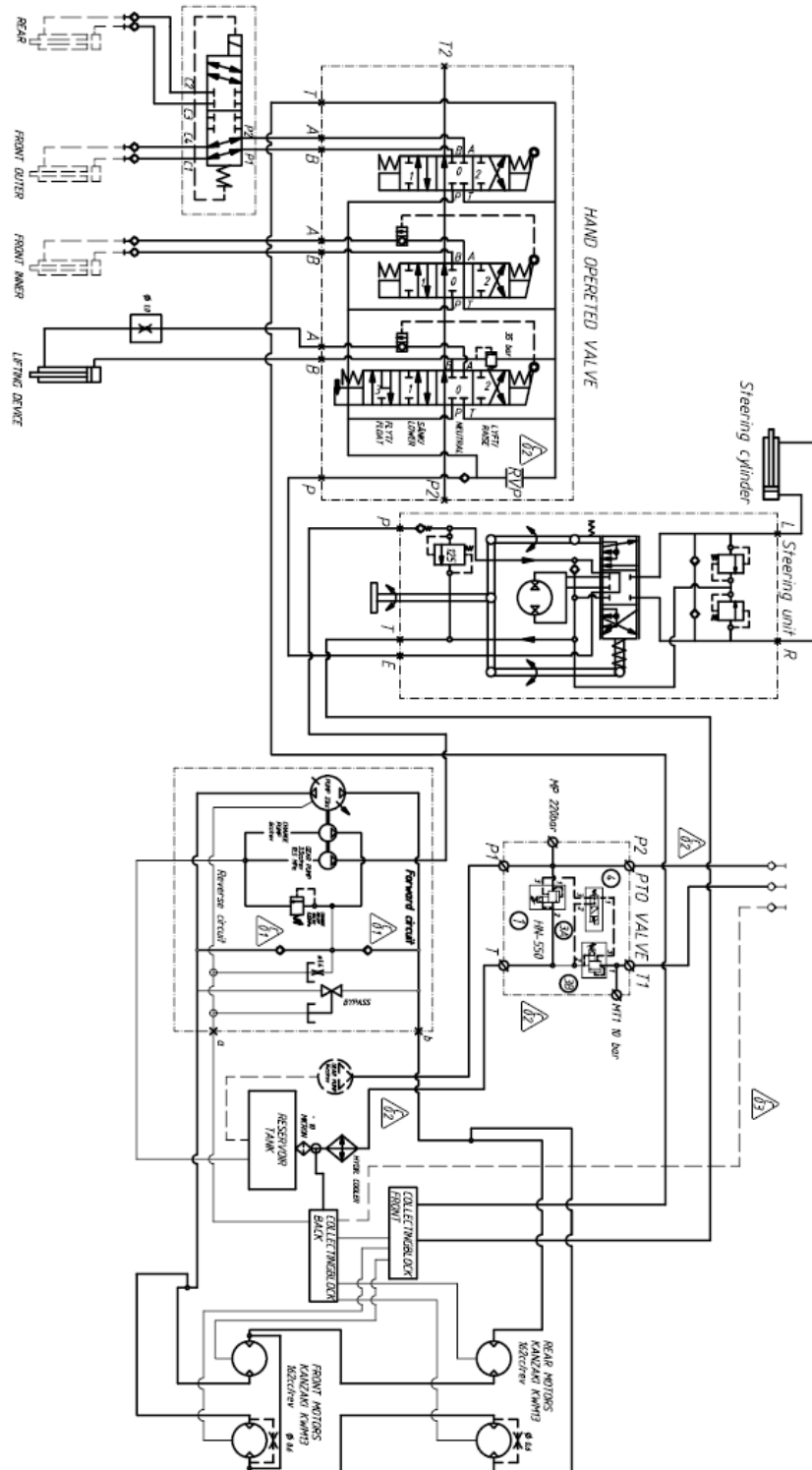

## 5 Control cables

### Contents

<b>5.1 Description</b> .....	<b>86</b>	<b>5.4 Throttle cable</b> .....	<b>93</b>
5.1.1 General .....	86	5.4.1 Description .....	93
5.1.2 Cable holders .....	86	5.4.2 Dismantling .....	93
5.1.3 Angle joints .....	86	5.4.3 Assembly .....	93
<b>5.2 Control cable</b> .....	<b>88</b>	5.4.4 Check .....	94
5.2.1 Description .....	88	5.4.5 Adjustment .....	94
5.2.2 Dismantling .....	88		
5.2.3 Assembly .....	89		
5.2.4 Check .....	89		
5.2.5 Adjustment .....	89		
<b>5.3 Brake cable</b> .....	<b>90</b>		
5.3.1 Description .....	90		
5.3.2 Dismantling .....	90		
5.3.3 Assembly .....	91		
5.3.4 Check .....	91		
5.3.5 Adjustment .....	92		

### General description

All mechanical control of the machine equipment is by cables.

This chapter will give a short description of repairs and replacement of equipment regarding cables.

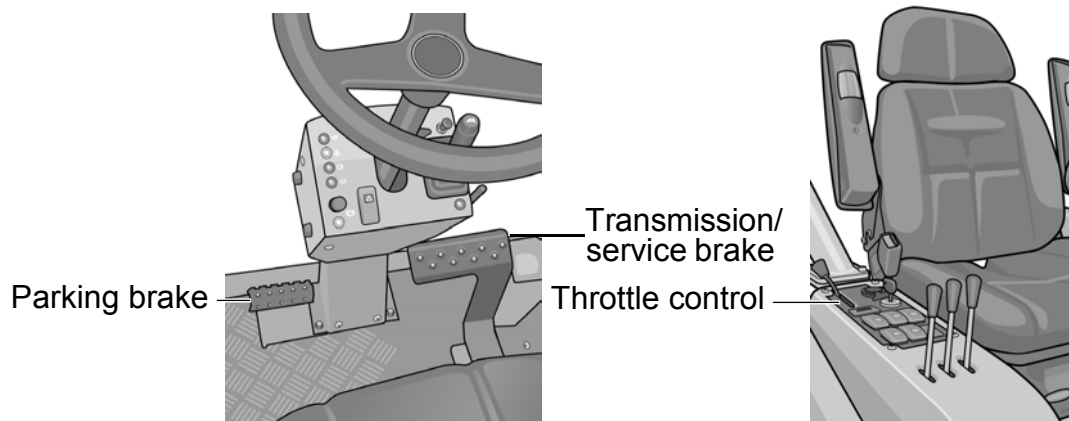

## 5.1 Description

### 5.1.1 General

All cables consist of a cable and a cable housing. In the cable ends one part, the cable or the cable casing, is fixed in the chassis and the other end in the lever arm. The lever arm is connected to the control and implement. That is the power take off, throttle damper, etc.

In most cases, the cables are installed with an adjuster sleeve and lock nut or angle joint at one or two ends.

#### Cable maintenance:

Apply a few drops of oil or use spray grease in the ends of the cable housings, two or three times a year.

### 5.1.2 Cable holders

All cables are mounted on the chassis with cable holders. When removing or replacing the cables new cable holders must be installed in the original positions.



Loose cables can cause unnecessary wear to the components. This can cause damage to plastic protection, paint damage, etc.

### 5.1.3 Angle joints

In several cases an angle joint was mounted in the end of the cable. The angle joint has the following two functions:

- To transfer movement to/from the relevant lever arm.
- To adjust the cable. The cable length is adjusted by screwing the angle joint on/off the threaded stay on the cable.

**Note** When adjusting at least 5 threads must be screwed in.

#### **Changing angle joint (see image below)**

1. Loosen nut 3 with an 8 mm spanner.
2. Remove nut 1 with an 8 mm spanner. Hold the angle screw with a 7 mm spanner.
3. Unscrew the angle joint from the stay.
4. Reassemble in reverse order.
5. When the assembly is complete, the cable must be adjusted.

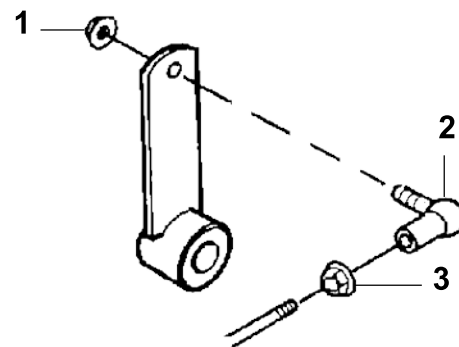

### Dismantling an angle joint

1. Fold spring washer A up from the angle joint body.
2. Pull out the spring washer.
3. Pry loose the joint body from the ball using a screwdriver or similar.
4. Reassemble in reverse order. The joint body must be pressed onto the ball using a polygrip or similar.

- !** Note!  
 It is important that spring washer A is inserted through both the angle joint holes. Otherwise the angle joint may fall apart during operation.

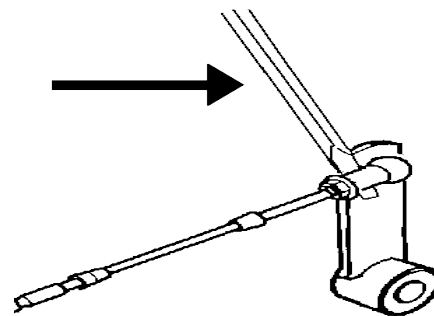

### Adjustment

1. Loosen nut 3 with an 8 mm spanner.
2. Dismantle the angle joint as described above.
3. Screw the joint body in the desired direction on the cable screw. Move nut 3 on the screw if necessary.
4. Check the adjustment result by pressing the angle joint in the ball without installing the spring washer.
5. After adjustment, assemble in reverse order and tighten nut 3 to the angle joint body.

- !** Note!  
 It is important that the spring washer 4 passes in through both the angle joint holes. Otherwise the angle joint may fall apart during operation.

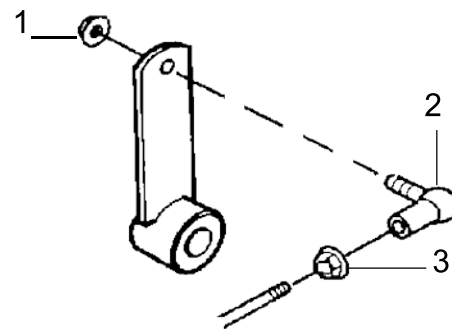

## 5.2 Control cable

### 5.2.1 Description

The control cable transfers the power from the drive pedal to the hydraulic pump lever arm. Because the pedal is also a service brake it is very important that the cable moves easily in its housing.

The cable transfers both thrust and tractive forces.

### 5.2.2 Dismantling

1. Disconnect the cable at hydraulic pump arm A and the adjuster nuts B at the hydraulic pump mounting.
2. Disconnect the cable at the front end C and adjuster nuts D from underneath.
3. Remove all securing straps. Note how the cable is routed so that the new cable can be reinstalled in the same way.

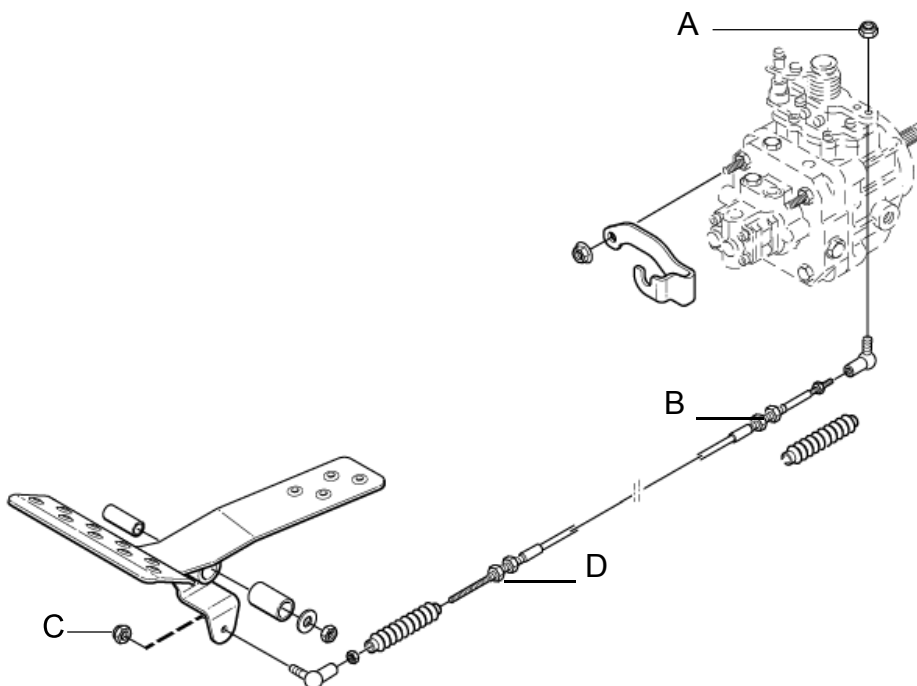

### 5.2.3 Assembly

1. Lubricate the cable through the end seals. Run the cable back and forth until oil has covered the length of the cable.
2. Install the cable in the same way as the one installed previously. Also see the image.
3. Adjust the cable. See "5.2.5".

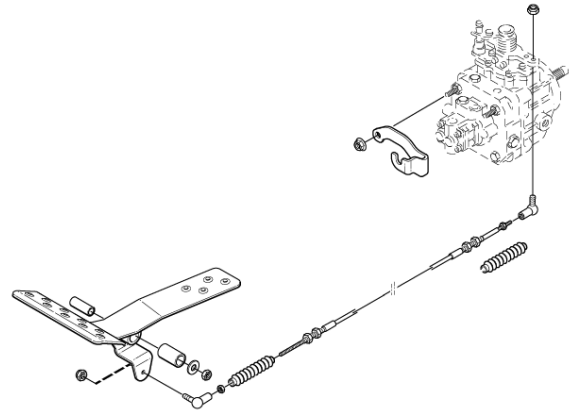

### 5.2.4 Check

- Check that the cable can move easily in the housing along the whole length of the stroke.
- Check that the cable is free of sharp kinks and other damage. The casing must be fault free so that water cannot penetrate.
- Check that the end seals are intact.

### 5.2.5 Adjustment

It is very important that the control cable is correctly adjusted, otherwise the maximum forward and backward positions cannot be reached as well as exposing the cable to greater stresses.

1. Remove circlip A and spring B on the hydrostatic pump.
2. Lock arm C on the hydrostatic pump in the full speed forward position.
3. Lock drive pedal D in the full speed forward position.
4. Adjust the control cable.

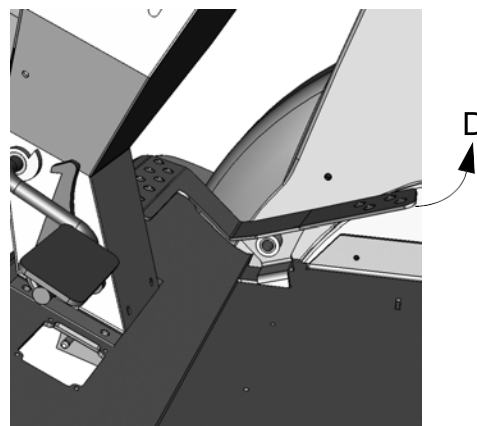
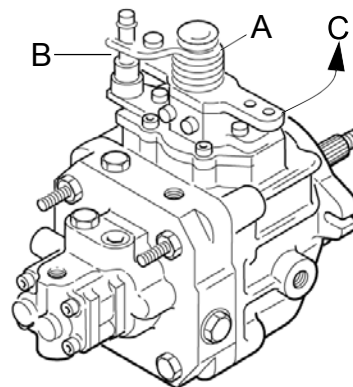

**Note** In cases where the cable is not sufficiently long to reach the maximum forward position on the pedal and on the pump the stop screw must be adjusted. At full speed forward the pedal must always be against the stop screw to prevent damage to the cable.

## 5.3 Brake cables



### Warning!

Never use a machine with faulty brakes.



The parking brake must not be used as a service brake and must only be activated when the machine is stationary. Incorrect use will damage the components.

### 5.3.1 Description

The brake cables transfer the movement from the parking brake pedal to the brake levers on the wheel motors. The brakes are part of the machine safety system. It is very important that the brake cables are fault free and correctly adjusted.

### 5.3.2 Dismantling

1. Remove the steering bracket's rear cover. See "3.1.1".
2. Slacken off screw A and release the cable ends.
3. Slacken off adjuster nuts B (2x).
4. Slacken off the adjuster nuts and unhook cables C (4x) from the springs on the wheel motors.
5. Note how the cable is routed so that the new cable can be reinstalled in the same way.

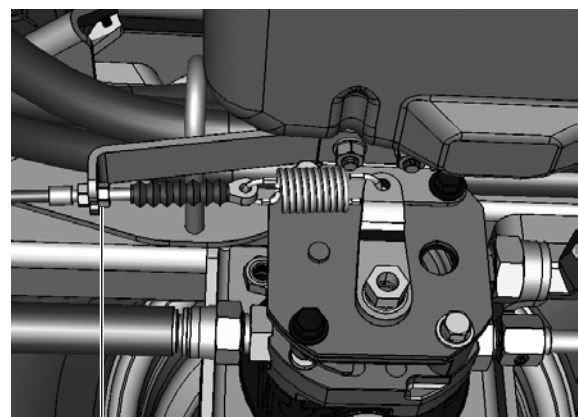
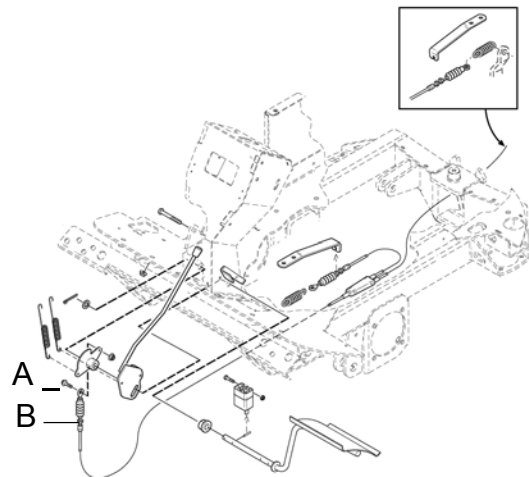

C



### 5.3.3 Assembly

1. Lubricate the cable through the end seals. Run the cable back and forth until oil has covered the length of the cable.
2. Install the cable in the same way as the one installed previously. Also see the image below.
3. Adjust the cable. See "5.3.5".

### 5.3.4 Check

- Check that the cable can move easily in the housing along the whole length of the stroke.
- Check that the cable is free of sharp kinks and other damage. The casing must be fault free so that water cannot penetrate.
- Check that the end seals are intact.

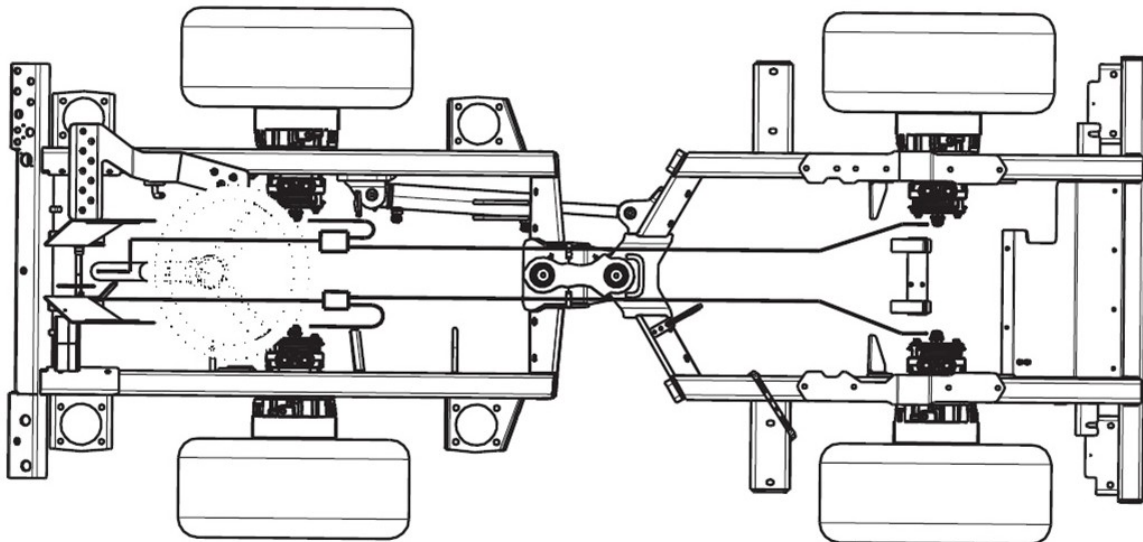

### 5.3.5 Adjustment



#### Warning!

**Never use a machine with faulty brakes.**

It is very important that the brake cables are correctly adjusted, otherwise the parking brake/emergency brake does not function as intended.

Adjust the brake cables as follows:

1. The spring must be completely unaffected when the brake is not activated.
2. Activate and lock the brake.
3. The spring body length must be 42 mm.
4. Adjust so that all four springs have the dimensions above.  
Attention! The cables can be adjusted at both ends.
5. Lock the adjuster sleeves with the nuts when the adjustment is complete.



Check that the cables are slack when the parking brake is not depressed. Incorrect adjustment causes greater wear to the brakes.

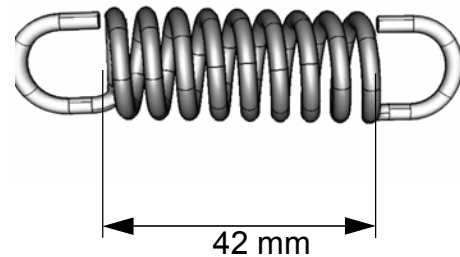

## 5.4 Throttle cable

### 5.4.1 Description

The throttle cable is integrated with the throttle control and is replaced as one unit.

### 5.4.2 Dismantling

1. Remove and lift off the cab.  
See "2.4.5".
2. Remove the front right side cover and the control panel. See "2.2.2".
3. Remove control knob A by screwing and simultaneously pulling it upwards.
4. Slacken off the screws B (4x) with nuts.
5. Remove the cable from the motor by locking screw C and the adjuster nuts D.
6. Note how the cable is routed so that the new cable can be reinstalled in the same way.

### 5.4.3 Assembly

1. Install the cable in the same way as the one installed previously. Also see the image.
2. Reinstall the other parts in reverse order.
3. Adjust the cable. See "5.4.5".

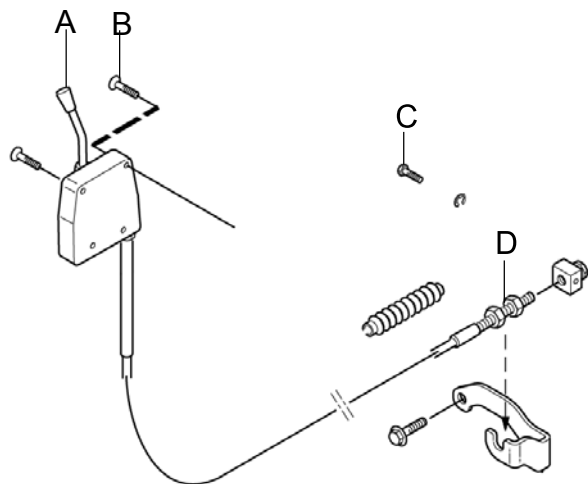

### 5.4.4 Check

- Check that the cable can move easily in the housing along the whole length of the stroke.
- Check that the cable is free of sharp kinks and other damage. The casing must be fault free so that water cannot penetrate.
- Check that the end seals are intact.

### 5.4.5 Adjustment

1. When the throttle control is in neutral position it must not be possible to move the arm closer to the idle position.
2. Put the throttle control at full throttle. In this position arm A should be against screw B.

Adjust the nuts of the housing adjuster sleeve to the criteria above.

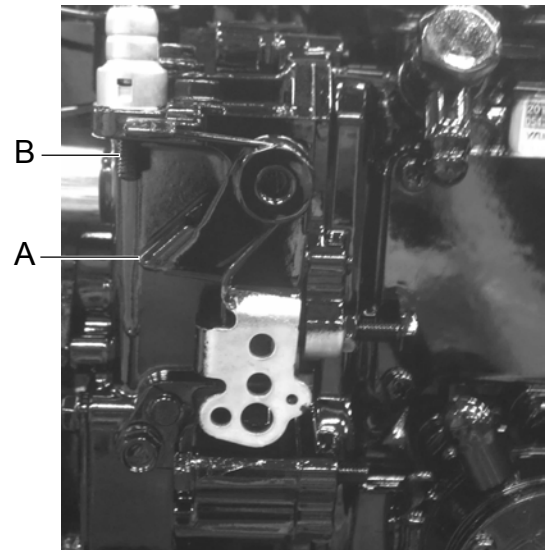

## 6 Electrical system

### Contents

<b>6.1 Description</b> .....	<b>96</b>	<b>6.3 Power cables</b> .....	<b>103</b>
6.1.1 Cable holders .....	96	6.3.1 Description .....	103
<b>6.2 Fault-tracing</b> .....	<b>96</b>	6.3.2 Cable (+) .....	104
6.2.1 The starter motor does not rotate ...	97	6.3.3 Rear cable harness .....	105
6.2.2 The startermotor rotates but the engine does not start .....	97	6.3.4 Front cable harnesses .....	107
6.2.3 Battery discharges repeatedly .....	99	6.3.5 Cab wiring .....	109
6.2.4 The engine does not stop .....	99	<b>6.4 Electric requirements to be able to start the machine</b> .....	<b>110</b>
6.2.5 The PTO does not function .....	100	<b>6.5 Repair and replacement</b> .....	<b>111</b>
6.2.6 Electric cutting height adjustment does not function .....	101	6.5.1 Central electrical module .....	111
6.2.7 The engine can be started without the parking brake depressed .....	101	6.5.2 Replacing fuses .....	112
6.2.8 The starter motor can be activated when the engine is running .....	102	6.5.3 Replacing switches .....	114
6.2.9 The sand spreader does not function .....	102	6.5.4 Replacing switch controls .....	114
		6.5.5 Connections .....	115
		6.5.6 Replacing headlamp bulbs .....	115
		<b>6.6 Control panels</b> .....	<b>116</b>
		<b>6.7 Wiring diagram</b> .....	<b>118</b>

### General description

The electrical system has two primary functions. To maintain the machines safety systems and facilitate certain functions.

The main part of this chapter will describe fault tracing in the electrical system. The fault tracing schedules are intended to assist in establishing electrical faults, in order to then take the correct action. This also describes common repairs and procedures for replacing certain components.

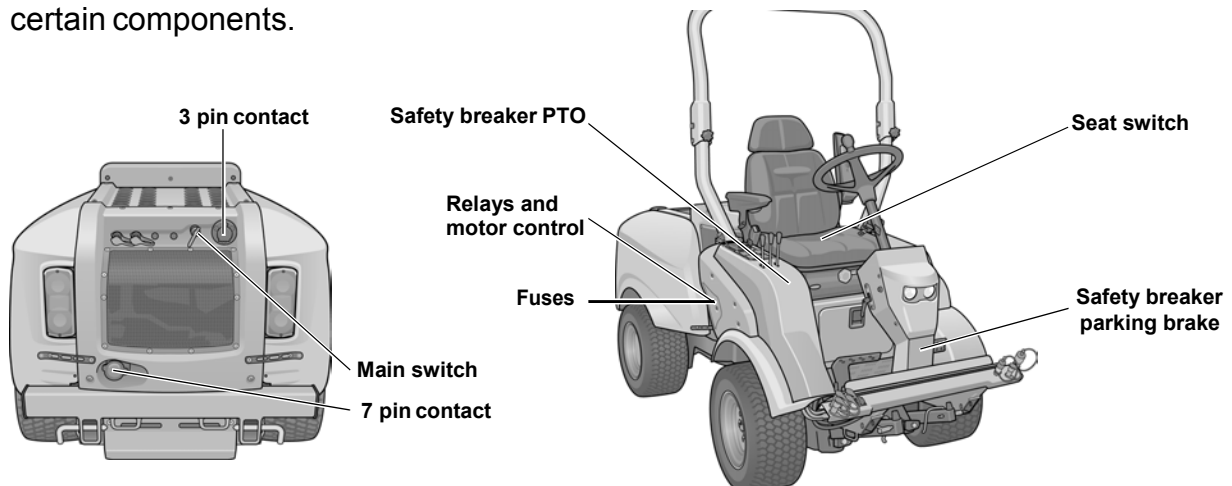

## 6.1 Description

The components of the electrical system are connected by cables, integrated in four cable harnesses, two front and two rear and positive/negative cables. The cable harnesses are connected at one of the front harnesses (main wiring) with a connector.

The electrical system consists of several safety circuits. Therefore certain controls and pedals are fitted with switches. The signal from the switches is used to open/close the circuit when a prohibited action is to be carried out. For example starting the machine requires that the parking brake is depressed and that the operator is sitting on the seat.

The wiring diagram must be read for full understanding of the electrical system of a special machine model. See "6.7".

All current supply with the exception of the starter circuit is protected by fuses.

### 6.1.1 Cable holders

#### Warning!

- ! It is important that all cable holders are securely fastened. If they are not there is a risk of short circuits and fire.

All electrical cables are mounted on the chassis with cable holders. When removing or replacing the electrical cables new cable holders must be installed in the original positions.

- ! Loose electrical cables can cause unnecessary wear to the components. This can lead to short circuits, damage to plastic protection, paintwork etc.

## 6.2 Fault-tracing

#### Warning!



**Do not wear rings, bracelets, necklaces or other similar metal items when working with the machine electrical system. It can lead to short circuits or fires.**

This section describes the fault-tracing procedures when an electrical fault has occurred in one of the machine functions. The section also describes what actions should be taken to rectify the fault. When the fault tracing schedule is to be used it is important that the following conditions are met:

- All fuses must be checked and replaced if necessary.
- The battery must be charged.
- The conditions for carrying out a procedure must be met. For example, if the engine is to be started the operator must be sitting on the seat, the parking brake must be depressed and the power take off in the disengaged position.
- The engine must be grounded to the battery negative.

When a fault tracing schedule is to be followed it is assumed that the cables are correctly connected to their terminals. In certain cases, after a long period of use or because of mechanical damage, wear to the cables can occur in, for example, the pivot point of the machine. For wiring diagram see "6.7".

### 6.2.1 The starter motor does not rotate

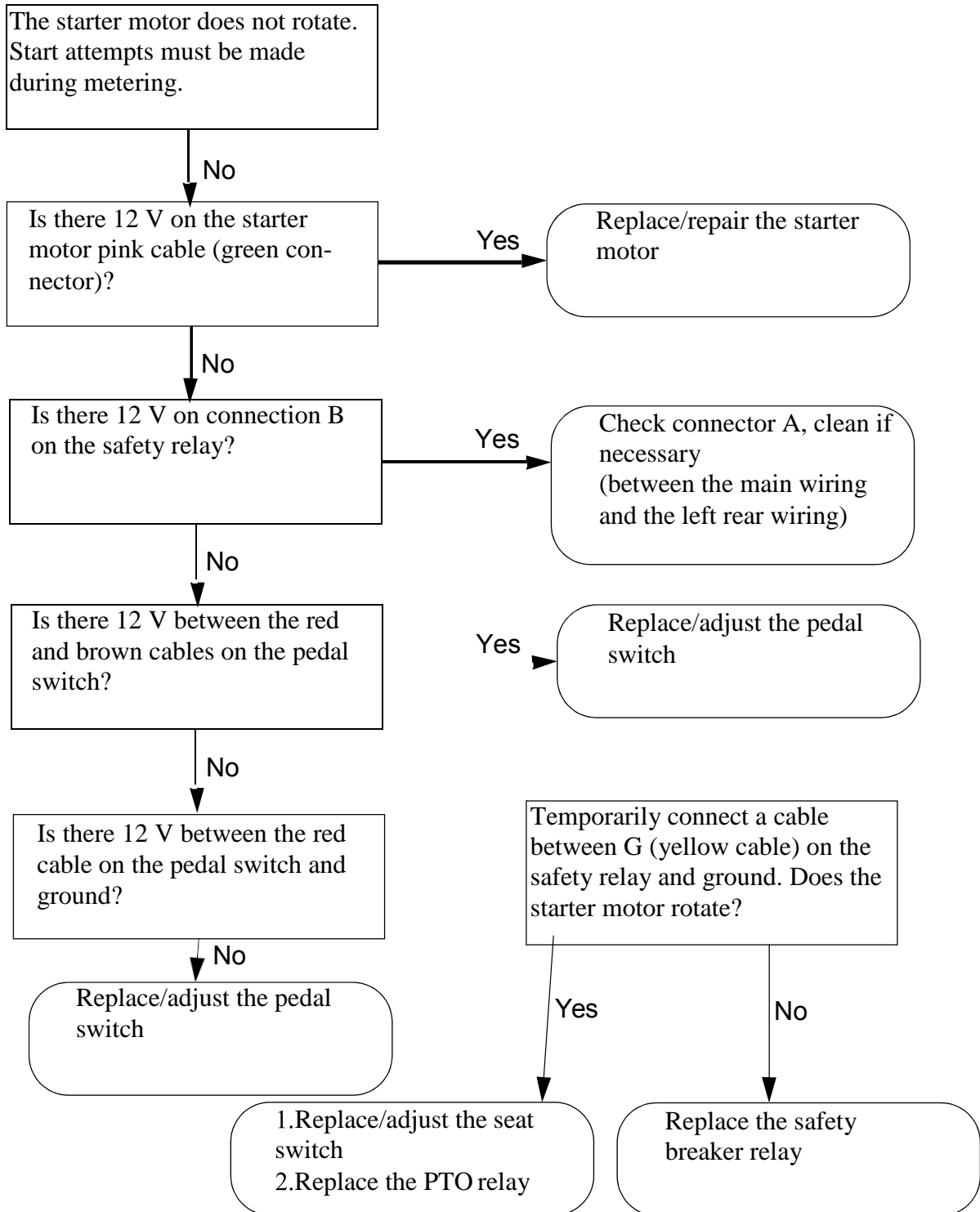

### 6.2.2 The starter motor rotates but the engine does not start

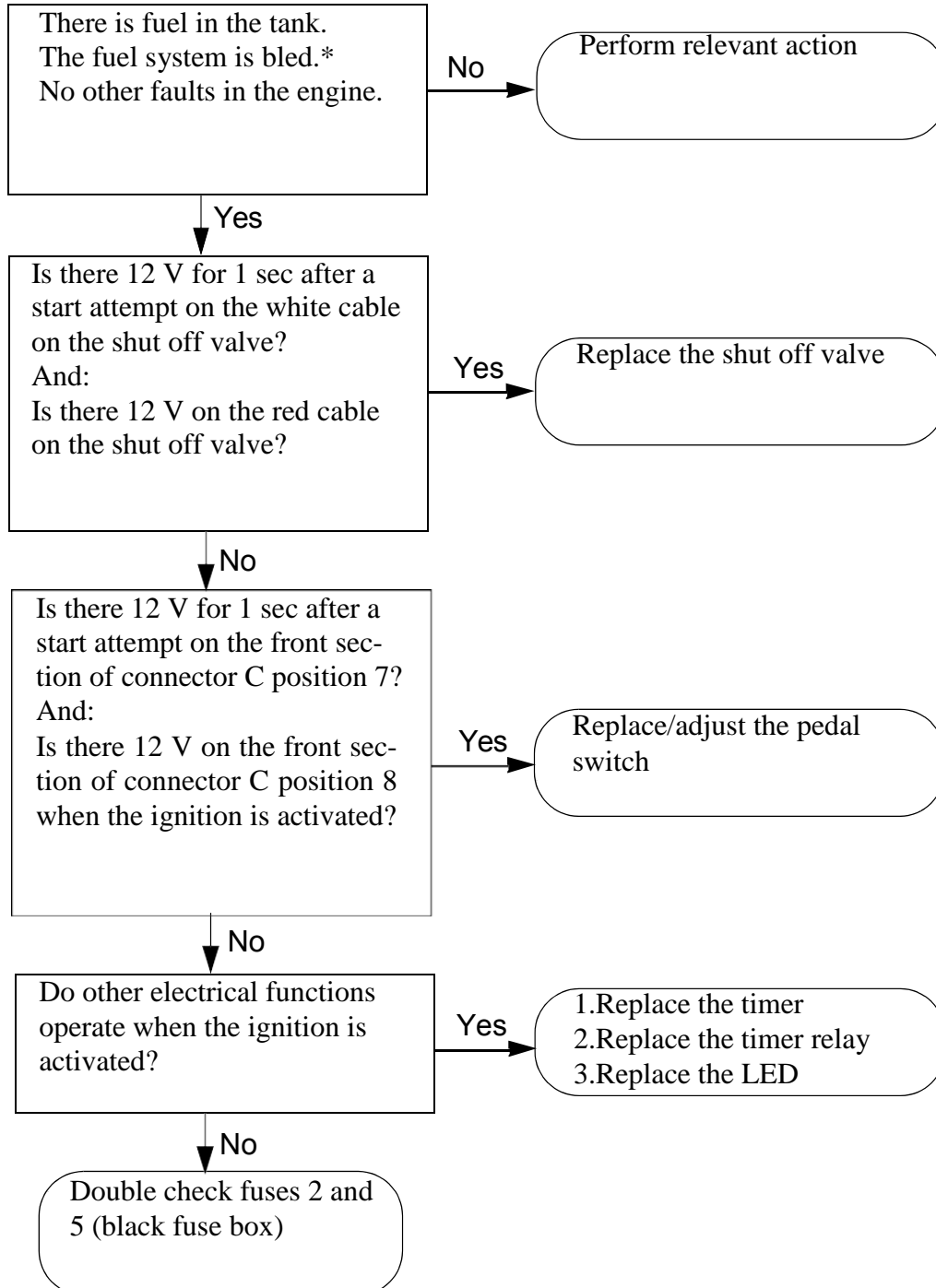

\* For venting the fuel system see 5.12 in the user instructions.



### 6.2.3 Battery discharges repeatedly

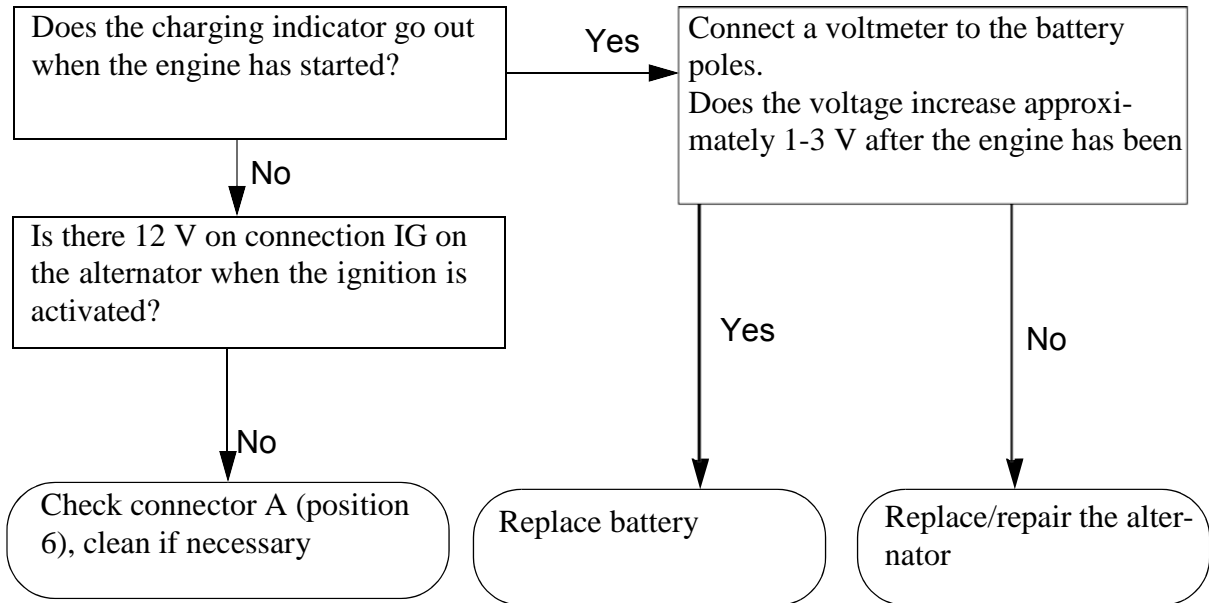

### 6.2.4 The engine does not stop

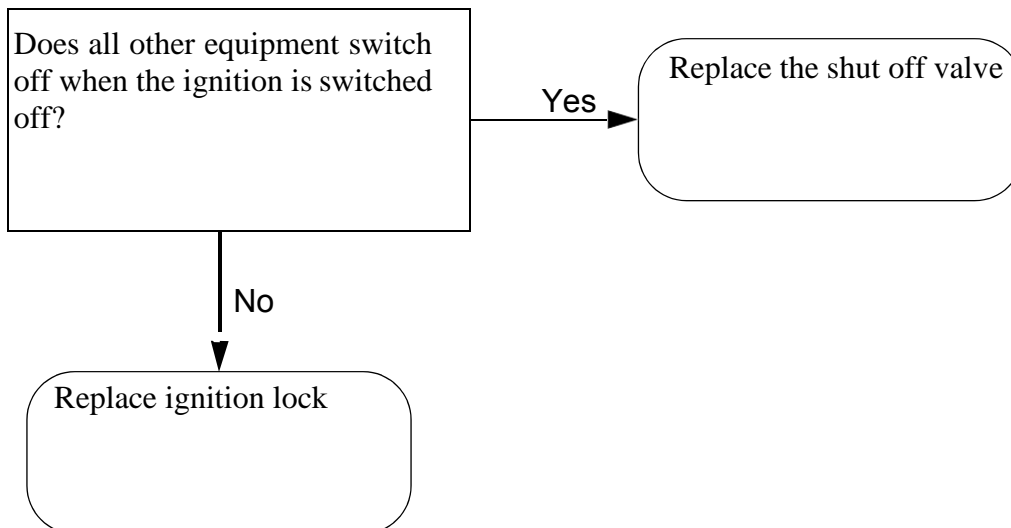

**6.2.5 PTO does not function**

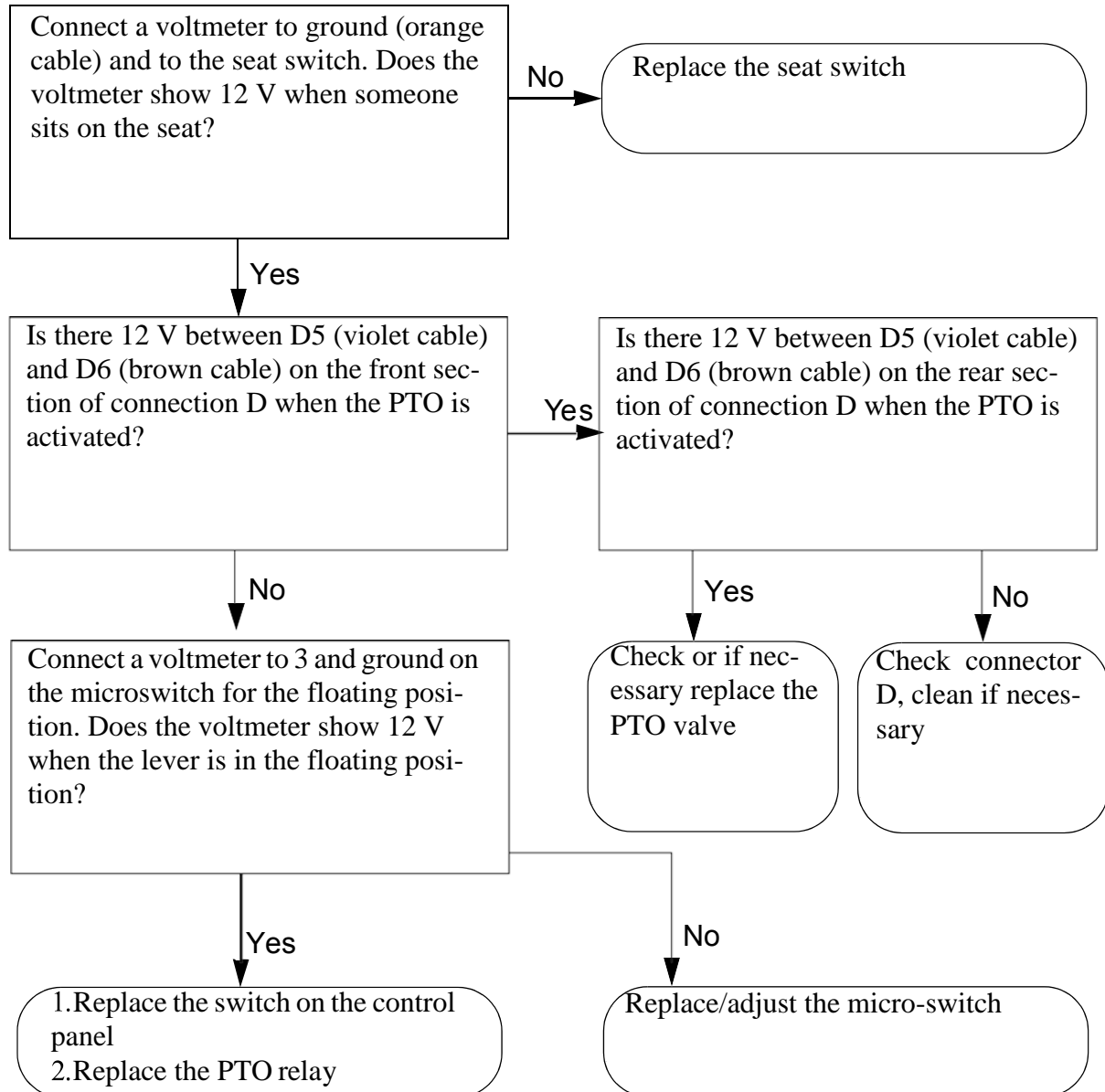

**6.2.6 Electric cutting height adjustment does not function**

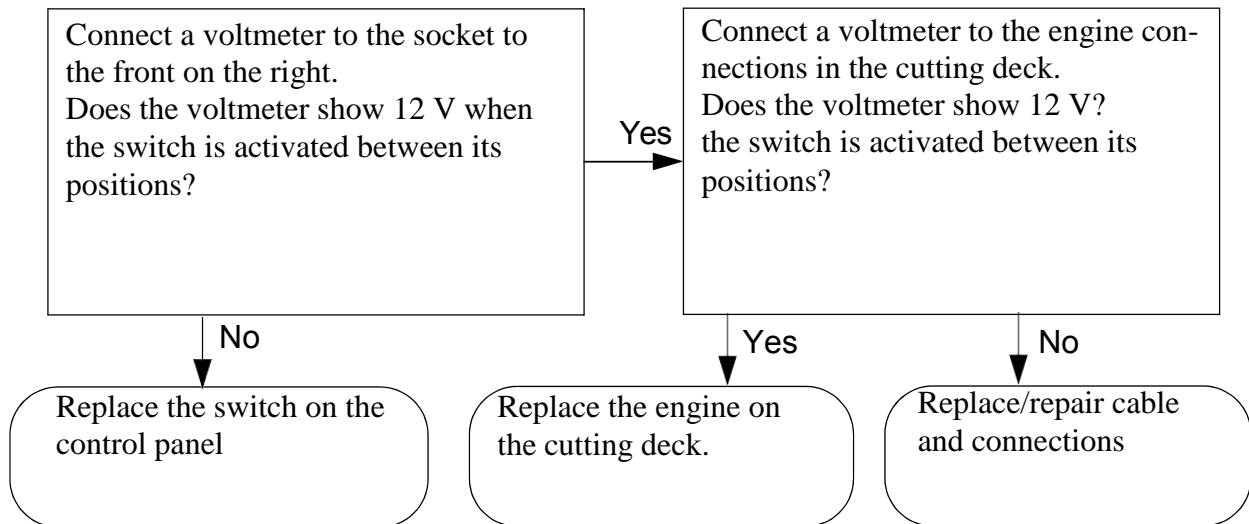

**6.2.7 The engine can be started without the parking brake depressed**

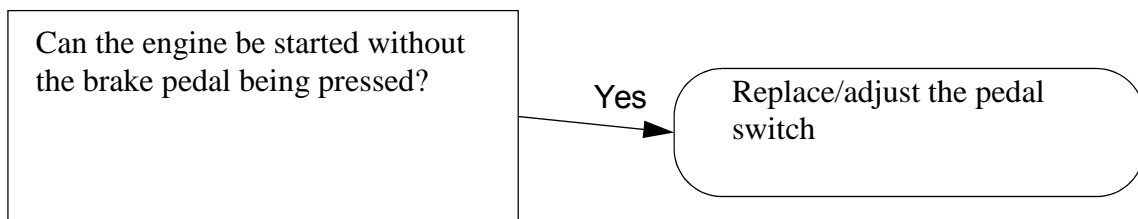

### 6.2.8 The starter motor can be activated when the engine is running

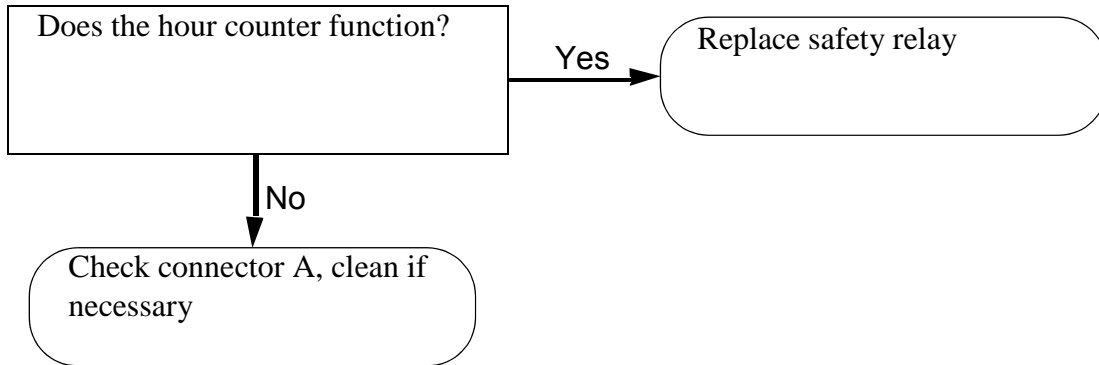

### 6.2.9 The sand spreader does not function

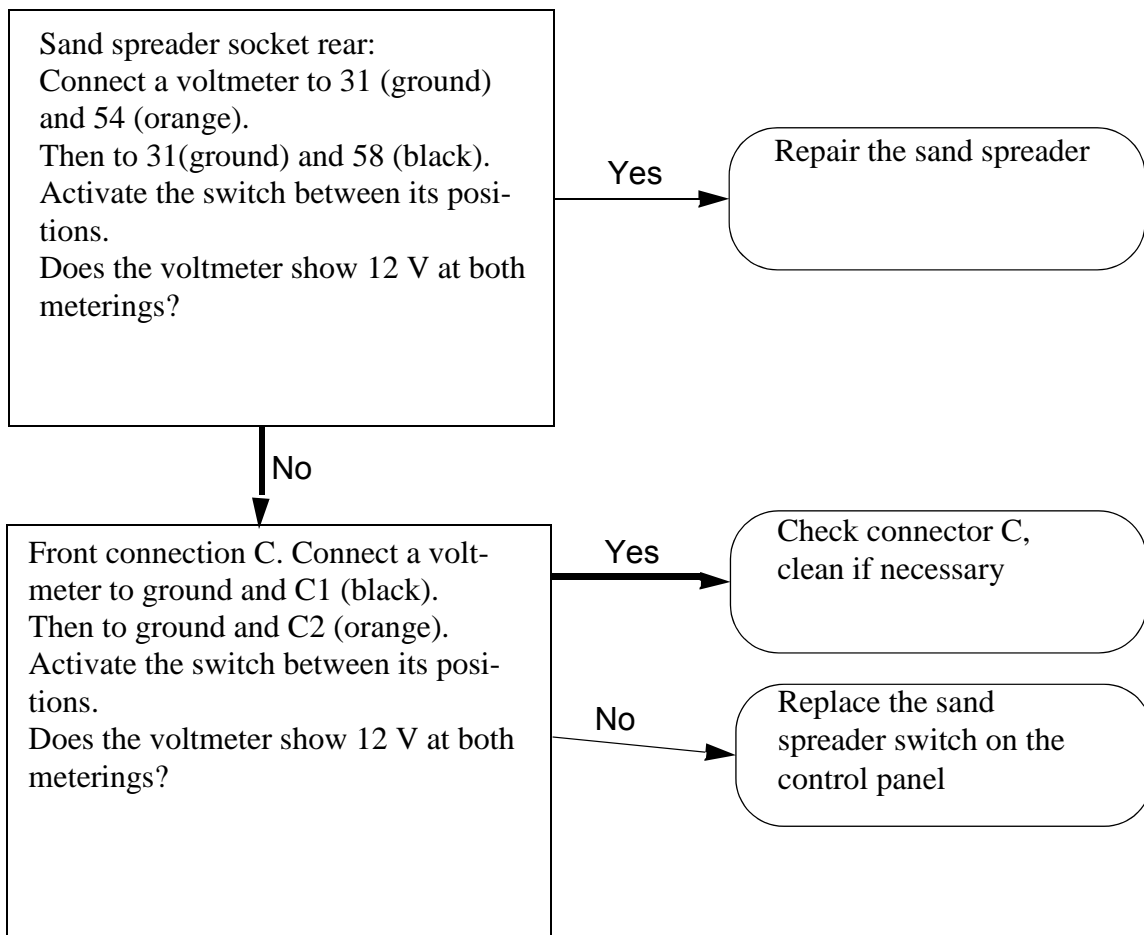

## **6.3 Power cables**

### **6.3.1 Description**

In this section the workshop manual will briefly describe how the electrical system of the machine is built up and display some of the cables and explain what the various connections are for.

The cables that the workshop manual covers are:

- Cable (+)
- Rear cable harness (left)
- Rear cable harness (right)
- Front cable harness (main wiring)
- Front cable harness (steering bracket)

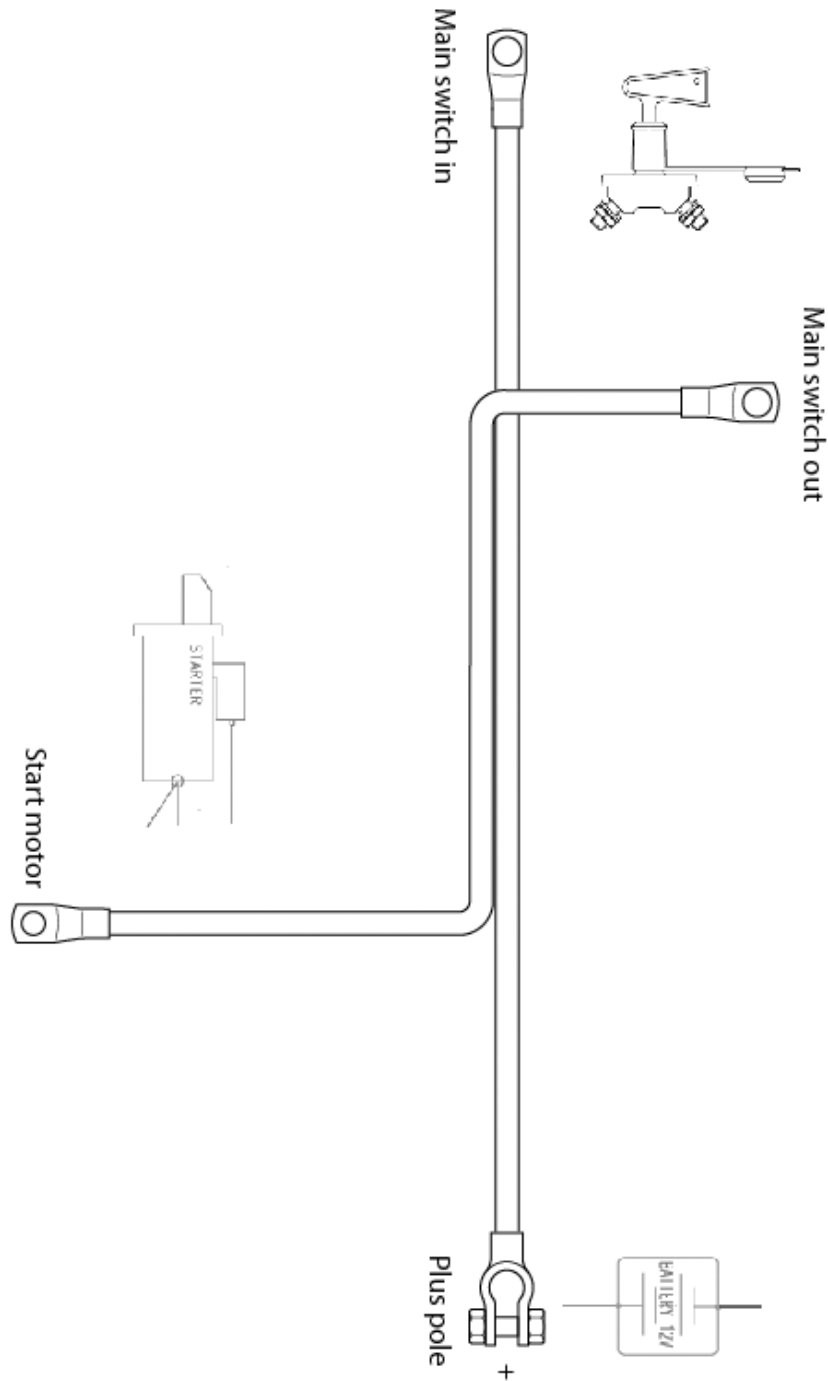
**6.3.2 Cable (+)**

### 6.3.3 Rear cable harness

#### Left cable harness

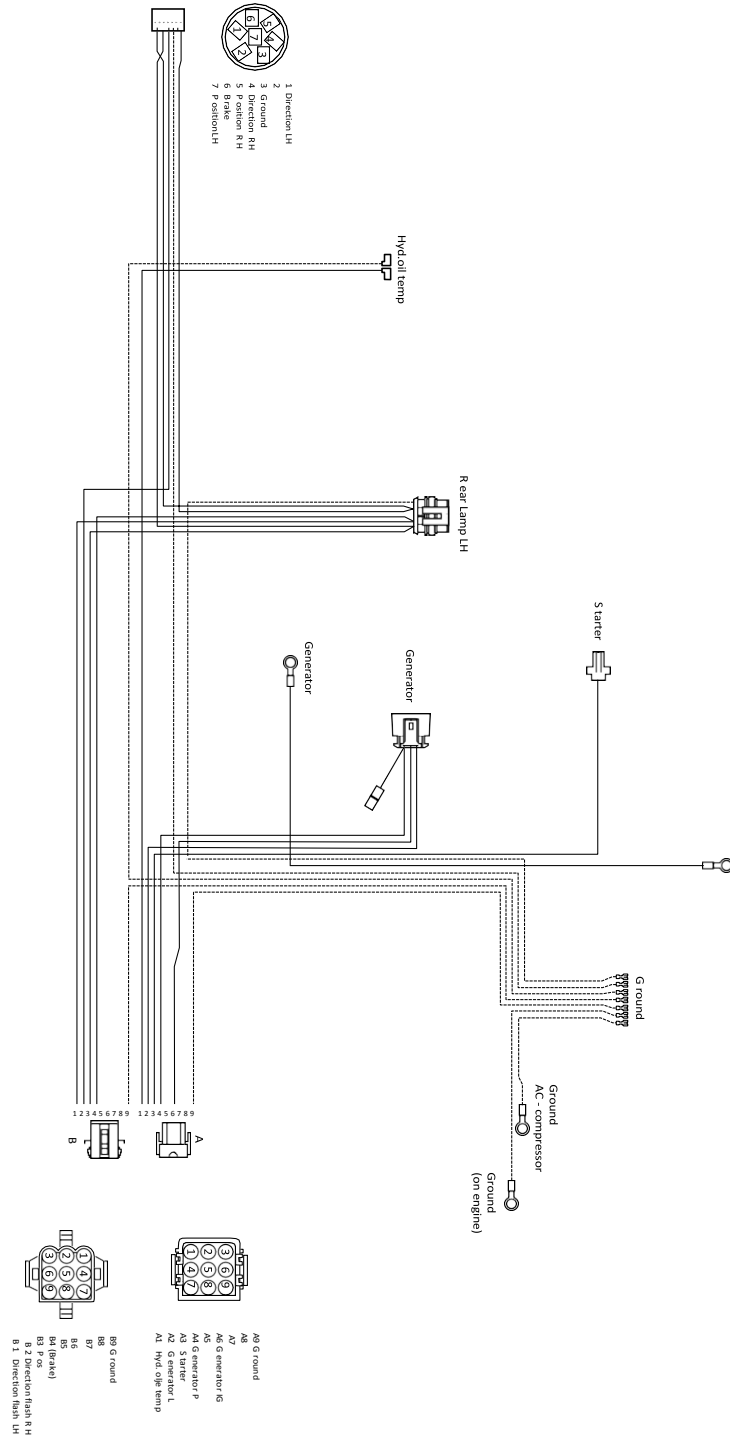

**Right cable harness**

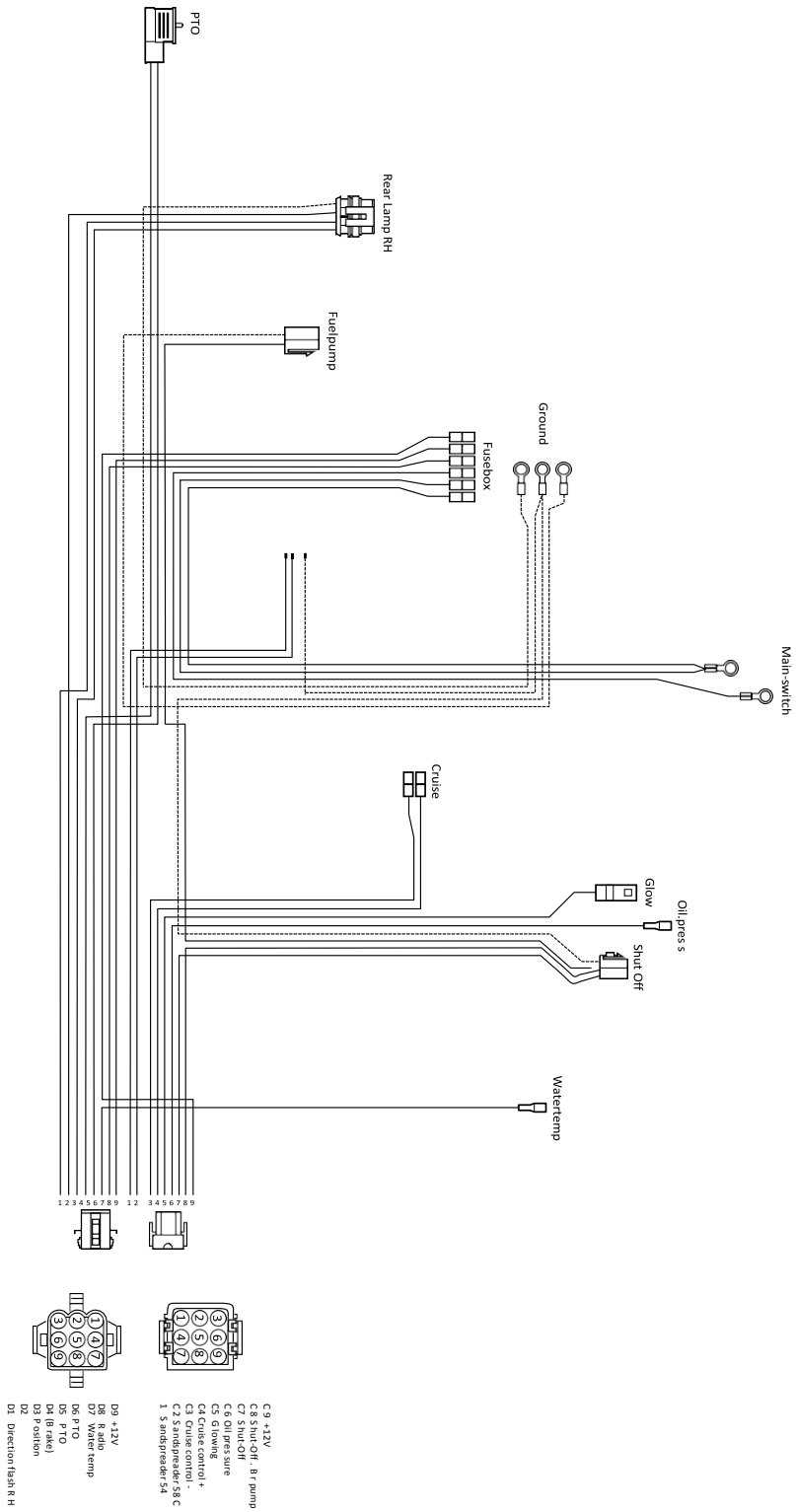







**6.3.5 Cab wiring**

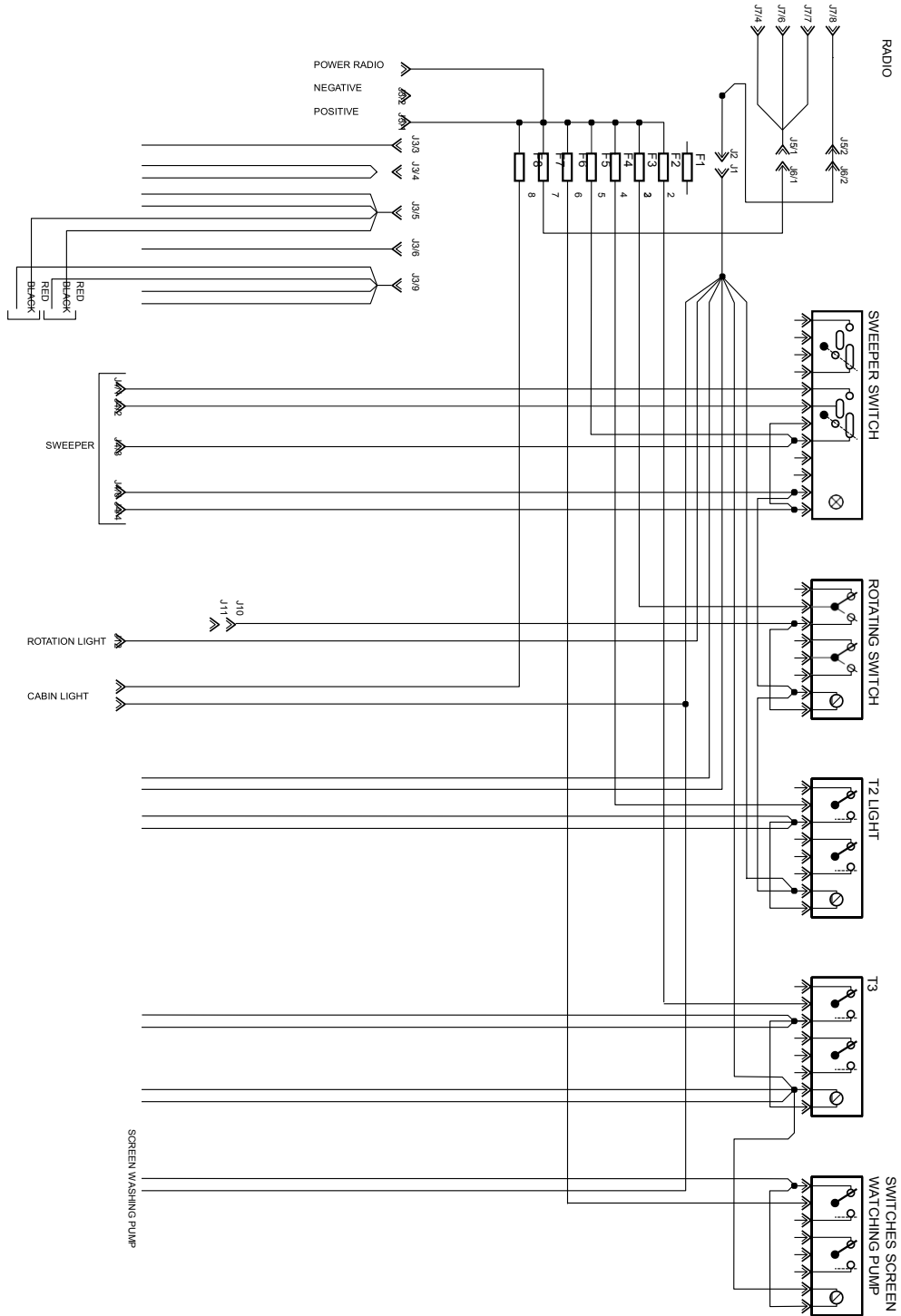

## 6.4 Electric requirements to be able to start the machine

A number of electrical conditions must be met for the engine to start. If one or several of the conditions are not met the engine will not start.

In order to start the engine the following conditions must be met on the connector to the control unit (for position see page 106):

1. Ground at switch position "G"  
Receives ground connection via the PTO relay and the seat switch when the PTO is not activated and someone sits on the seat.
2. Voltage in position "C"  
Receives current through the fuse and the pedal switch when the pedal for the parking brake is depressed when the ignition is on.
3. No pulses at position "H"  
The engine must not be running.
4. Voltage in position "E"  
Is obtained when the starter key is in the "START" position.

When points 1-4 are met the relay in the control unit closes and the starter motor operates.

### Fault-tracing

Check the points above to see if one or more of the conditions is not met and is causing the machine not to start.

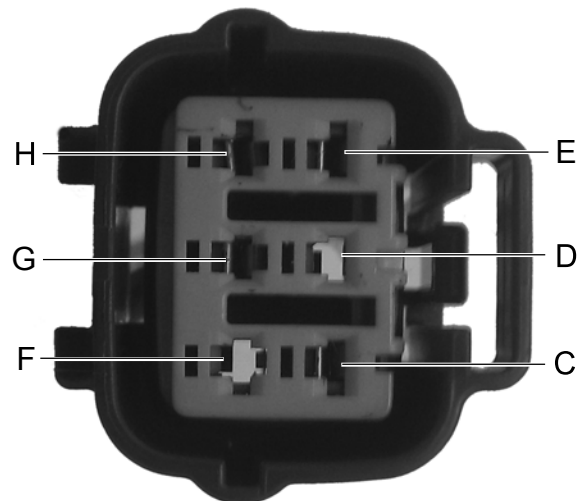

## 6.5 Repair and replacement

### Warning



**Do not wear rings, bracelets, necklaces or other similar metal items when working with the machine electrical system. It can lead to short circuits or fires.**

### 6.5.1 Central electrical module

Most electrical components are located under the two covers by the control panel.

Remove the right side cover, if necessary also remove the control panel. See "2.2.2" for description of dismantling.

#### Relay locations

The relays are located under the front side cover on the right side. All relays are listed below.

- A. AC relay
- B. Turn signal relay (Road kit)
- C. Fuel valve relay (shut-off)
- D. Control unit (safety relay)
- E. PTO relay
- F. Cab relay (dipped beam, AC, main fuse cab, turn signal lamps)
- G. Dipped beam relay (Road kit)

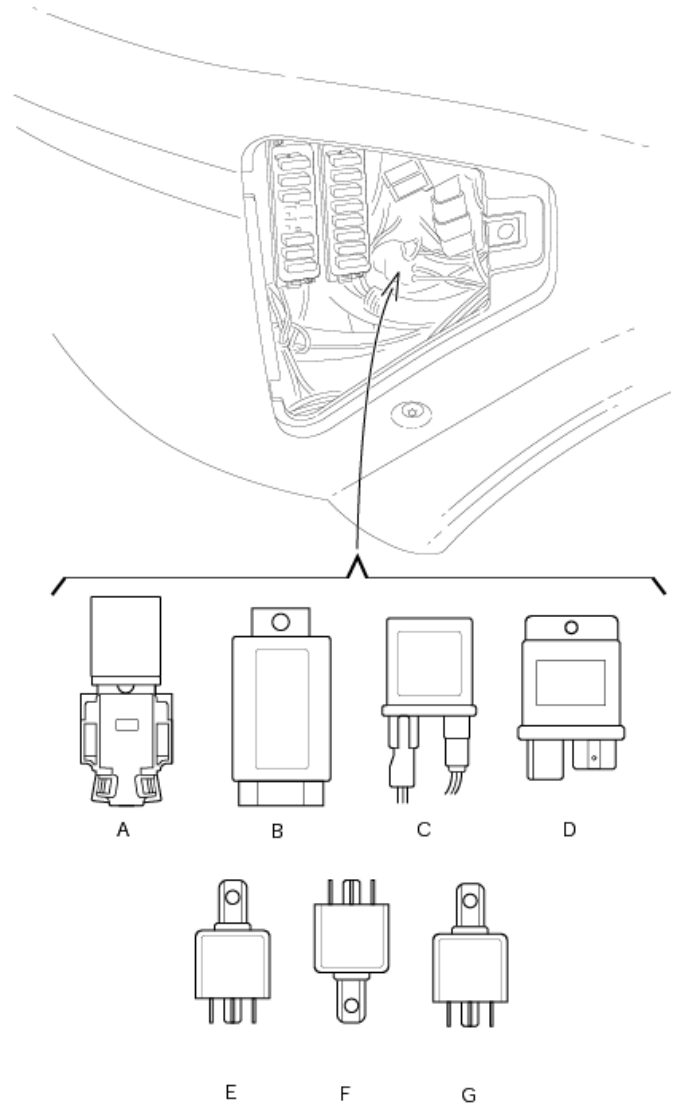

## 6.5.2 Replacing fuses

Note!

- ! The current strengths given in this section are the maximum values of the fuse that may be installed. If a higher current fuse is installed there is a risk of fire damage to the machine.

The machine has three fuse boxes.

One fuse box is in the roof of the cab and contains the fuses for the cab's electrical functions. The fuse box is under the control panel in the roof and is accessible by removing the control panel screws.

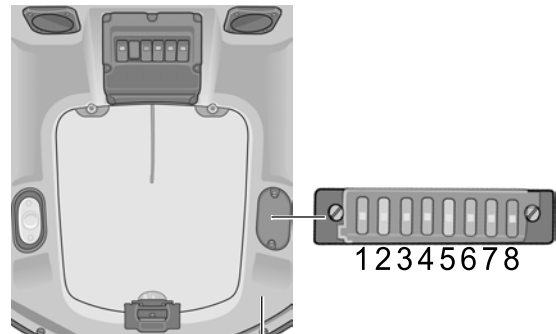

Designation	Fuse	
	Location	Rating
Spare	1	
Radio	2	3 A
Work lighting	3	10 A
Heated mirror	4	10 A
Windscreen wiper	5	10 A
Washer fluid pump	6	3 A
Rotating warning lamp	7	7.5 A
Inner lighting	8	3 A



Two fuse boxes are located in accordance with the figure to the right. These contain the fuses according to the table below:

In the event of electrical faults, check and replace blown fuses.

Designation	Fuse	
	Location	Rating
Dipped beam	A1	20 A
AC	A2	20 A
Main fuse, cab	A3	30 A
Turn signal lamps	A4	10 A
Spare	A5	
Parking lights, Horn, Dipped beam relay	A6	10 A
Hazard warning lights	A7	10 A
AC	A8	10 A
Indicator lamps, Buzzer, hold valve transport position	B1	10 A
Cutting height, Sand spreader, rear rake	B2	20 A
Cruise control, Alternator	B3	10 A
Electric socket on panel	B4	10 A
Shut off pull	B5	30 A
PTO, warning lamp parking, safety relay	B6	10 A
Spare	B7	
Main fuse	B8	40 A

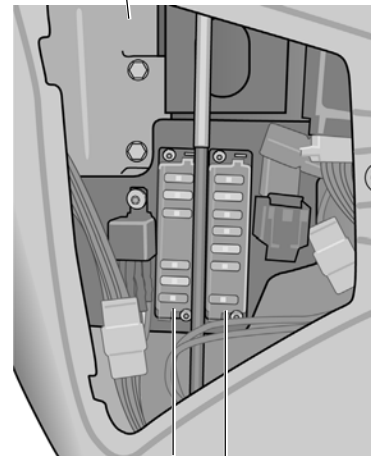

A B

### 6.5.3 Replacing switches

The switches are pressed into place in their respective rectangular holes in the control panel. To change a switch, follow the procedure below:

1. Remove the relevant protection to make the switch accessible.
2. Press in the fixing hook in the connection and pull the connection from the switch.  
See figure.  
Certain connections have 2 fixing hooks.
3. Press the fixing tabs, on both sides of the switch, against the switch. Use a screwdriver or similar to slide the switch up.  
See figure.

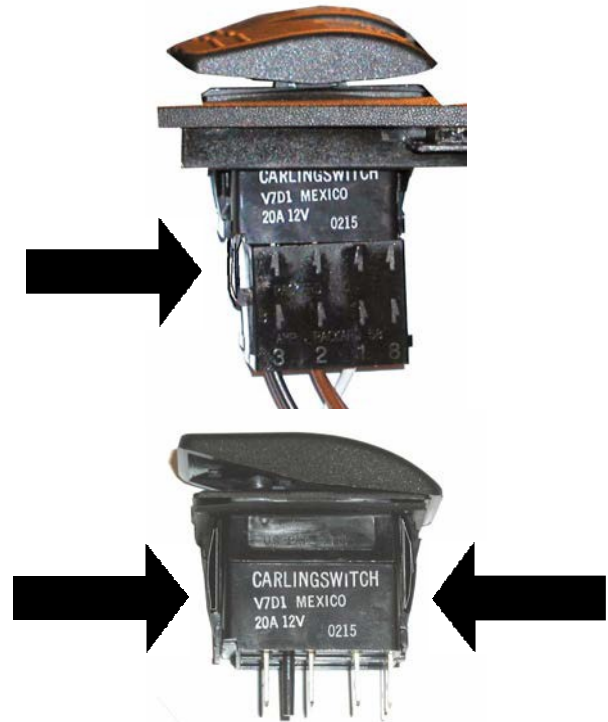

### 6.5.4 Replacing switch controls

To remove the switch use a special tool. The tool reference number is in the replacement parts list.

Remove the button by pressing in the tool from behind. Press until the button hops up.

The button is easily installed by pushing down into the switch hole.

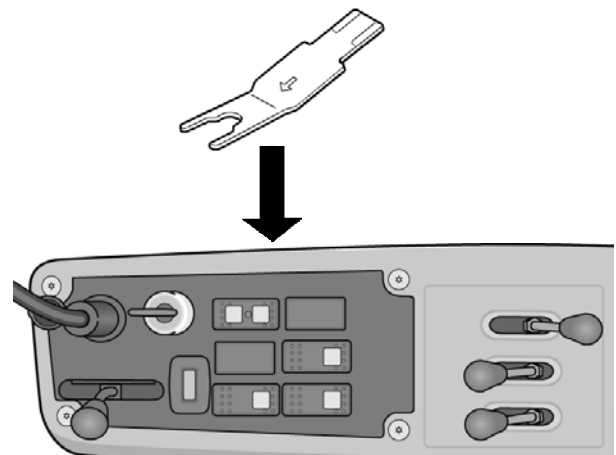



### 6.5.5 Connections

All connections must be kept clean of dirt, rust and moisture.

Use a small screwdriver to remove a flat pin connector from the plastic holder. Press in the screwdriver behind the connection, hold the cable and pull out the cable with the connection. To reuse reset the catch to its previous position.

Crimping pliers can be used to restore a flat pin connector, when it has been exposed to long term wear and tear. Other types of connectors may require special tools for removal.

#### Warning!

- ! **No metal from the cable may be visible outside the screw connection. Too long stripped cables can cause short-circuits or fires.**

### 6.5.6 Replacing headlamp bulbs

In standard form, machines without cabs are equipped with two 12V lamps, 20W. They are aimed 15° from each other. Replace the lamps as follows:

1. Remove the cover by removing the 4 screws.
2. Remove the relevant lamp by unscrewing the two screws and disconnecting the electrical connection.
3. Reassemble in the reverse order.

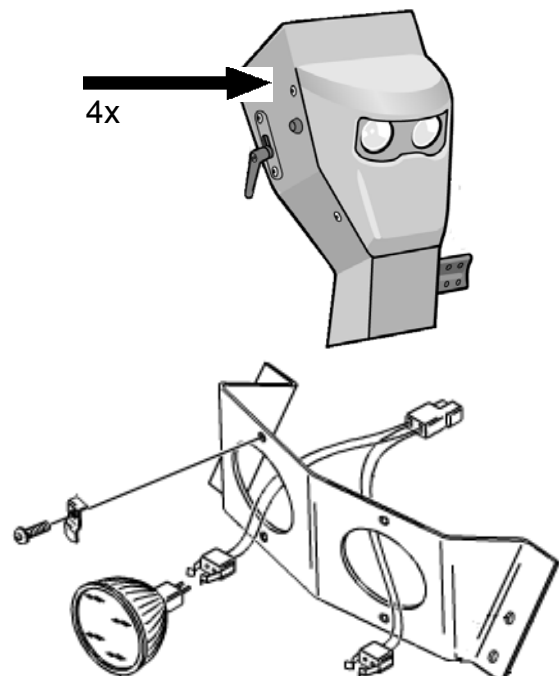

## 6.6 Control panels

### Switch A1



The switch can be used to smoothly set the cutting height of the cutting deck with electric cutting height adjustment. The switch controls the contact (A) with switching polarity.

### Switch A2



Switch for engaging and disengaging the operation of the front mounted implement. Two positions:

1. Press the front part of the switch – PTO engages. The symbol will light up.
2. Press the rear part of the switch – PTO disengages.

### Switch A3

**12V** The switch has three positions and can be used for the sand spreader for example. The switch controls the contact (B).

### Switch A4



The switch has two positions and indicates which hydraulic socket will be activated by the control.

### Hour meter A5

Indicates the number of working hours. Only works when the engine is running.

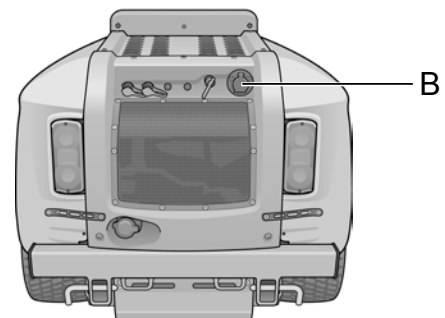
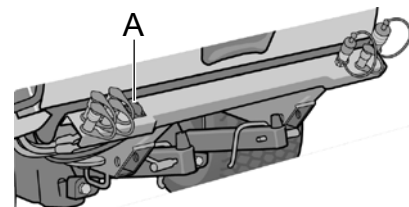
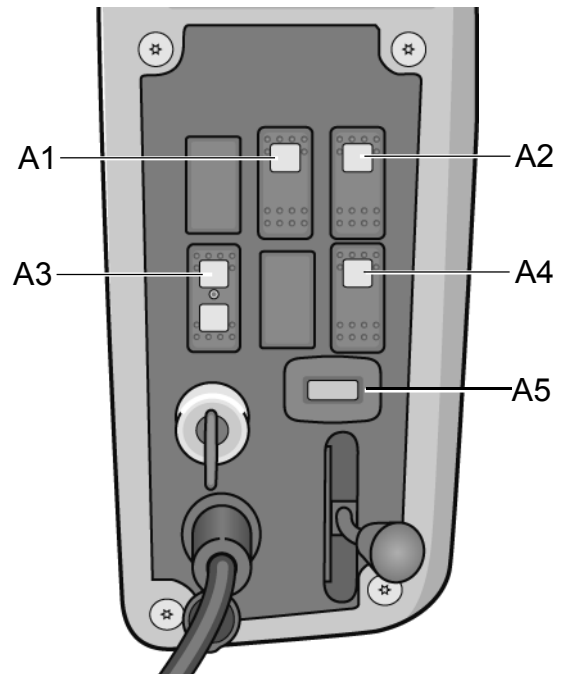

### Windscreen washer B1



The switch is located in the roof and is used to activate washing.

### Warning beacon B2 (740 DCR)

**Obs!** Follow applicable laws regarding use of the warning beacon.



The switch is located in the roof and is used to start and stop the rotating warning beacon that is positioned on the roof of the machine.

### Work lighting B3

**Obs!** Follow applicable laws regarding use of the work lighting.



The switch is located in the roof and is used to switch the work lighting, positioned on the front of the machine, on and off.

### Windscreen wiper B4



The switch is located in the roof and is used to start and stop the windscreen wiper.

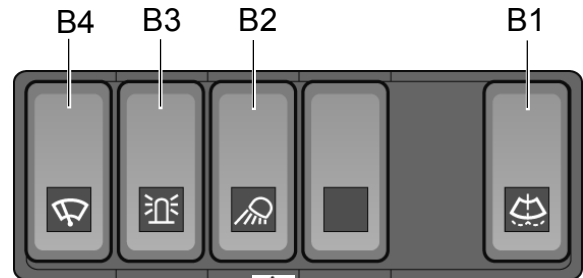



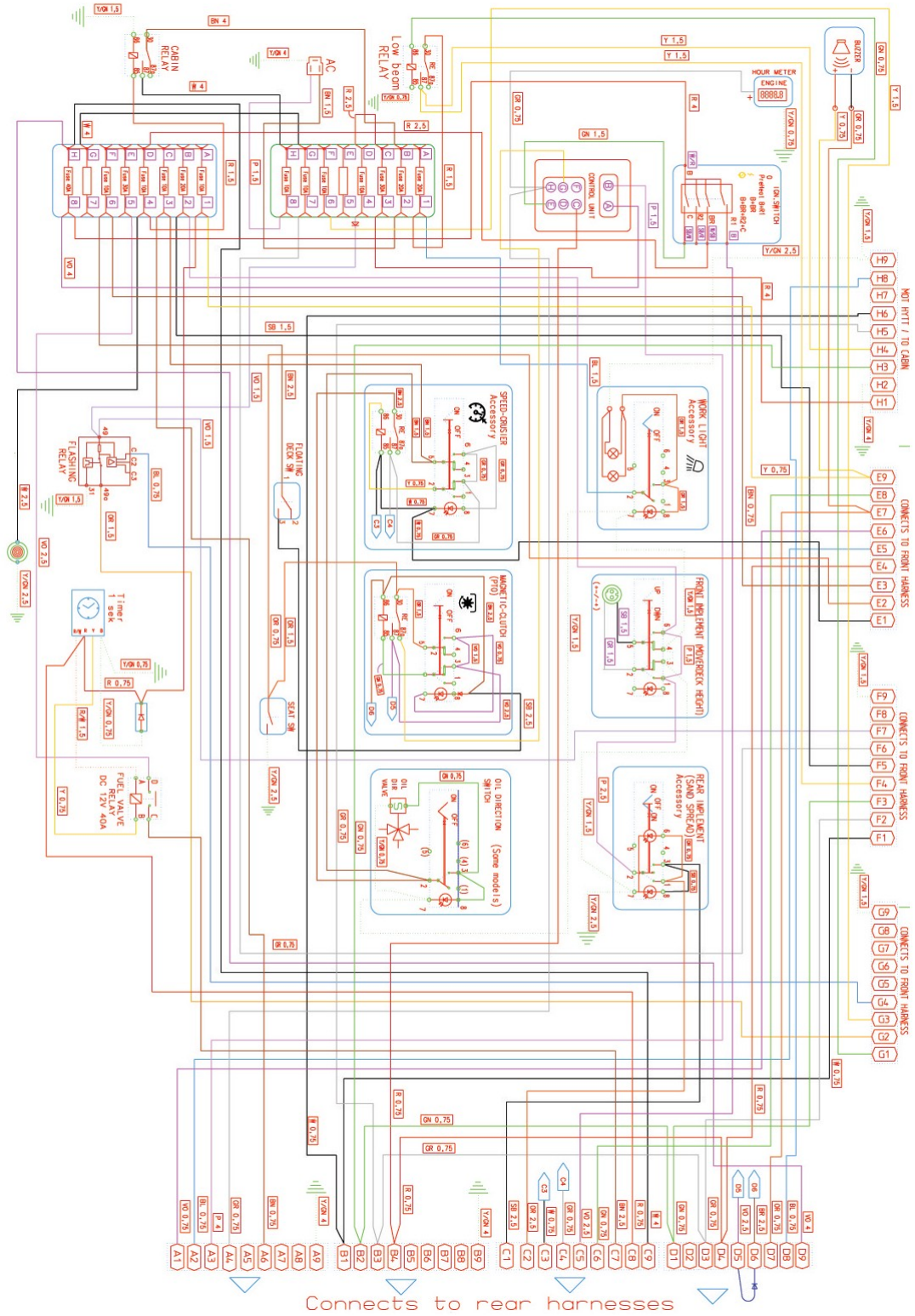

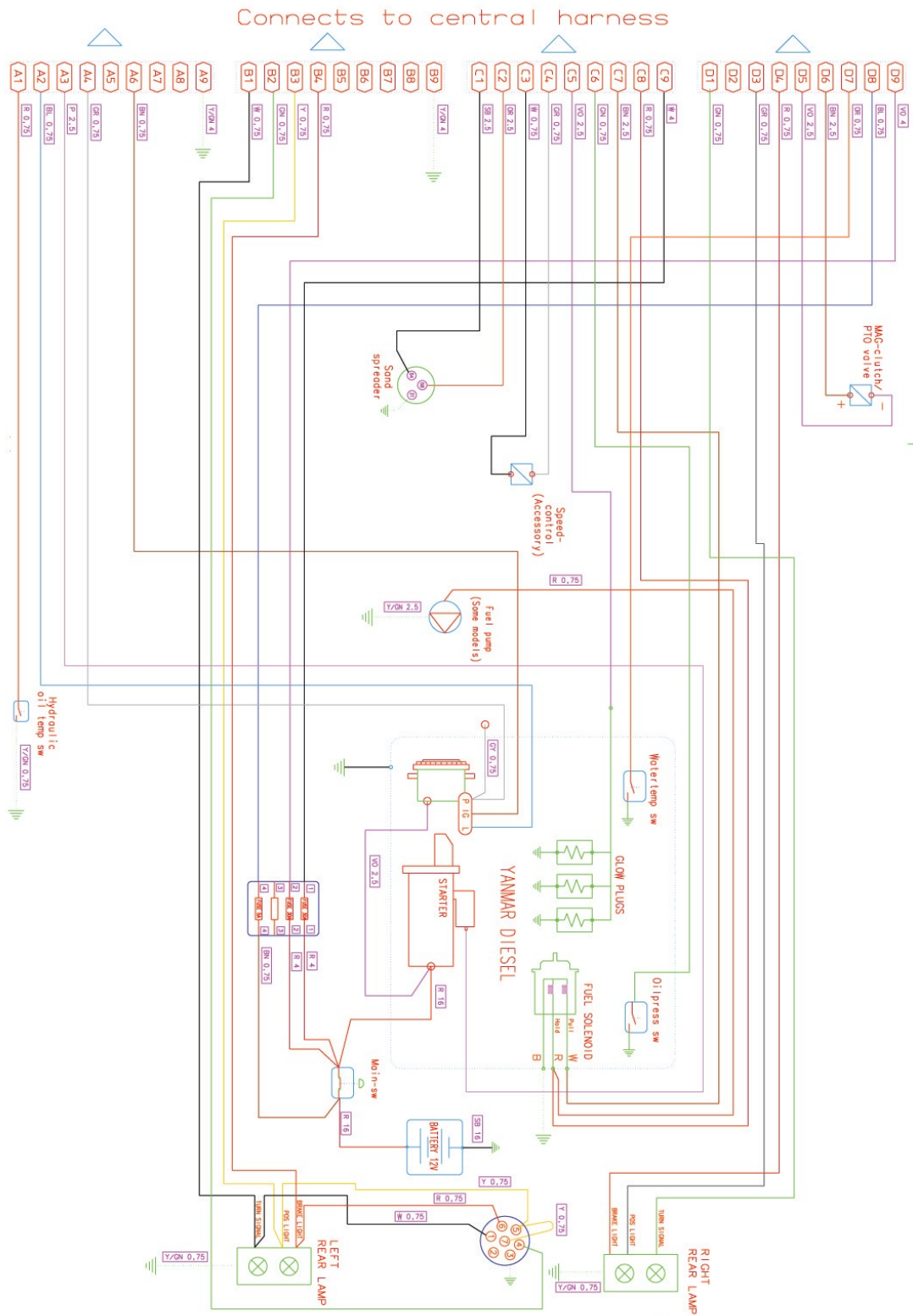

**STIGA**

STIGA S.p.A - Via del Lavoro, 6 - 31033 Castelfranco Veneto (TV) - Italy  
[www.stiga.com](http://www.stiga.com)