

STIGA



WORKSHOP MANUAL



IMPORTANT NOTICE

The information contained herein is intended for Service Operations and professionals only, able to competently perform the operations described herein, using the appropriate equipment in order to safeguard se-curity and performance of the machine.

The manufacturer is not liable for damages or injuries arising from operations performed by individuals or inadequate facilities.

- The Manufacture reserves the right to make any improvements to the product of a technical or commercial nature that may be necessary. There maybe, therefore, differences between the various series of machines and that described here, though the basic features and various repair methods will remain the same.
- © by STIGA - No use of the illustrations or duplication, reproduction or translation, even partial, of the texts in this document may be made without explicit authorization.
- All brands, names, logos and trademarks mentioned belong to their respective owners.

72FL - 72FL Hydro - Edition 2018--->....



GENERAL INFORMATIONS

The purpose of this manual is to assist Service Centres with service, disassemble and repair the versions of the machines:

- **72FL** = mechanical driven;
- **72FL Hy** = hydrostatic driven.

The manual has left out the simplest and quickest operations that can be handled by a good mechanic, while concentrating more on specific aspects with tips and advice on the best servicing procedures.

Please take time to read through this manual to acquire a basic understanding of the machine, which is necessary for working rationally without making errors or wasting time.

All problems related to the use of the machine are fully covered in the User manual.

STRUCTURE OF THE MANUAL

The manual is divided into sections and chapters. Each page of this manual states the following information:

- A) Machines or series of machines to which the contents of the chapter are applicable.

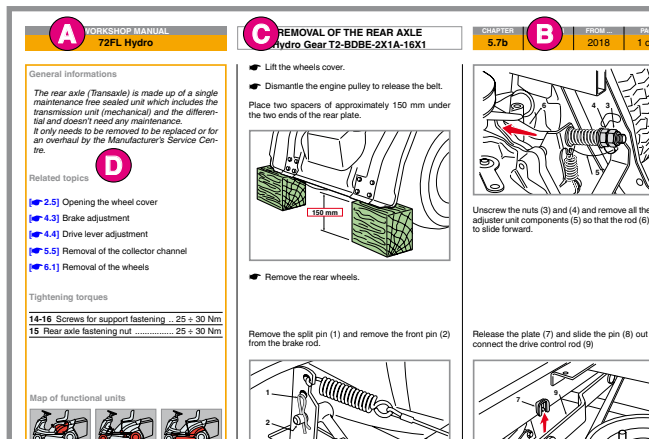

HOW TO USE THE MANUAL

- B) Identification and number of the page based on the following criteria:
- the first field indicates the section and chapter;
 - the second field indicates the revision index;
 - the third field indicates the chapter validity start date, i.e. the year of manufacture of the machine;
 - the fourth field indicates the page number and total number of pages dedicated to the subject.
- C) Chapter title.
- D) General information, references to other chapters in the manual, technical information related to the topic, and buttons with links to the machine operating units map can be found in the left column on each initial page.

SECTIONS OF THE MANUAL

The content of the manual is divided into sections which correspond to the various subjects and the different types of servicing.

1. Rules and procedures for Service Centres

This chapter covers all the main aspects of the relationship between the manufacturer and the service centres.

A close collaboration between the manufacturer and the service centres is conclusive for solving problems in the most effective way as well as maintaining an image of efficiency and reliability. Compliance with these brief and simple guidelines will facilitate this task and prevent general misunderstandings and time-wasting for both the manufacturer and the service centre.

2. General regulations

This chapter covers the main aspects of a servicing procedure and the general rules for guaranteeing a successful service which protects the environment and respects the safety of both the serviceman and the user of the apparatus.

CHAPTER	REVISION	FROM ...	PAGE
i	2	2018	1 of 2

3. Maintenance

This chapter covers the main aspects of a servicing procedure.

A specific chapter is dedicated to a quick troubleshooting guide on the most frequent questions and the chapter references providing information on the interventions required to resolve the same.

4. Adjustments and tuning

This chapter deals with the adjustments to be made to remedy the more frequent performance failures and are usually resolved by quick checks and tunings.

5. Removal of external parts and main assemblies

For doing more difficult jobs, greater accessibility may be required. This can be done by taking the unit concerned off and working at the bench, or by removing the cover or other external parts.

Whether or not this will be useful is at the discretion of the mechanic's experience.

6. Repairs

This chapter deals with all the more complex work connected with the replacement or repair of malfunctioning or worn parts.

The descriptions must follow a logical sequence and can include operations not specifically connected to a particular type of repair.

In this case, careful reading of the entire procedure can help you omit all those operations not connected with the case in hand without, however, overlooking anything that may be necessary.

7. Electrical system

This chapter deals with the problems and checks connected with the electrical system.

All work can be done using a tester without having to use special equipment.

The electrical diagrams can be useful to you for

HOW TO USE THE MANUAL

CHAPTER	REVISION	FROM ...	PAGE
i	2	2018	2 of 2

understanding how the system functions and to facilitate the pinpointing of any problems.

8. Technical specifications

This chapter summarises all the main information regarding the machine.

FUNCTIONAL UNITS MAP

The map is a search tool that provides instant access to all information concerning machine operational unit or element. Identification is simplified by the use of icons resembling the various units, each of which is linked to a table of contents that lists all related topics.

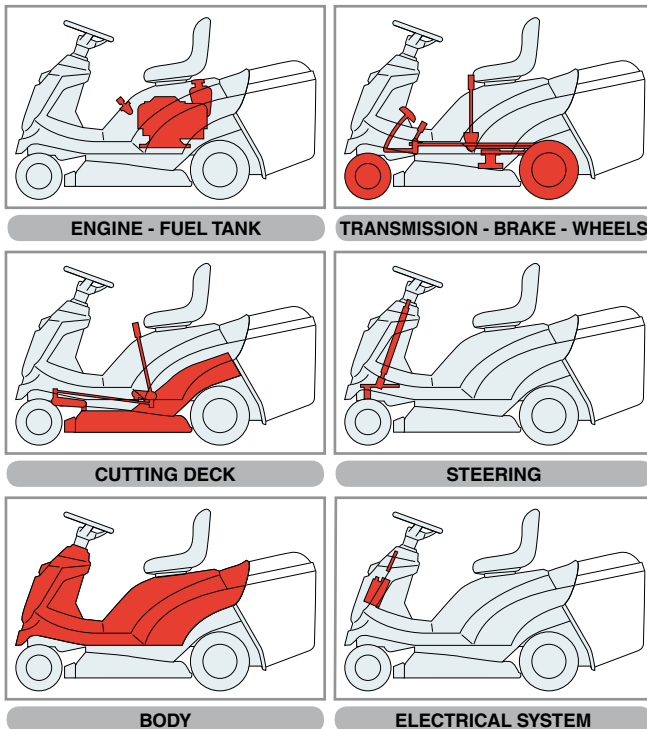

SYMBOLS

In the manual some symbols are present. They are used to draw the attention of the operator, reminding him to perform the interventions with the necessary attention and caution.

- Indicates operations that should be carried out with utmost care to avoid impairing the functionality and safety of the machine.
- Indicates operations that should be carried out with utmost care to avoid injury to operators.
- Highlights all those operations that require different working methods depending on the type of machine, subsequent modifications and the accessories fitted.
- Indicates cross-reference to other parts of the manual, followed by the number of the relevant chapter, paragraph or sub-paragraph.

TERMINOLOGY AND ABBREVIATIONS

Some paragraphs are preceded by a definition that highlights their importance:

NOTE General reference for the correct maintenance execution and methods..

IMPORTANT Specific procedures or information necessary to avoid damage to the machine or equipment.

WARNING! Non-observance will result in the risk of injury to oneself or others.

DANGER! Non-observance will result in the risk of serious injury or death to oneself or others.

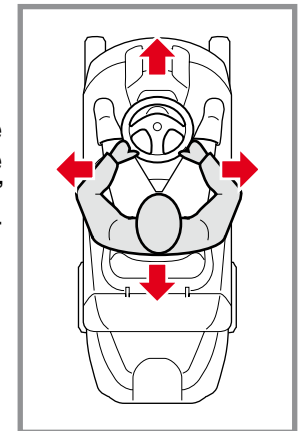

Whenever reference is made to a position on the machine "front", "back", "left" or "right" side, this refers to the positions of the seated operator.

The following abbreviations are used in this manual

- Dx / Sx = Right / LeftV
- Min / Max = Minimum / Maximum
- Chap. = Chapter
- PTO = Power Take Off
- HST = Hydrostatic Transmission

General informations

Different fittings are foreseen for this machine which can imply the use of different engines within the same.

This manual only describes the operations relating to the application of the machine engine; reference to the engine's Manufacturer's Manual is recommended for information regarding servicing, disassembly and replacement of components.

Related topics

[👉 1.1] Identification of components

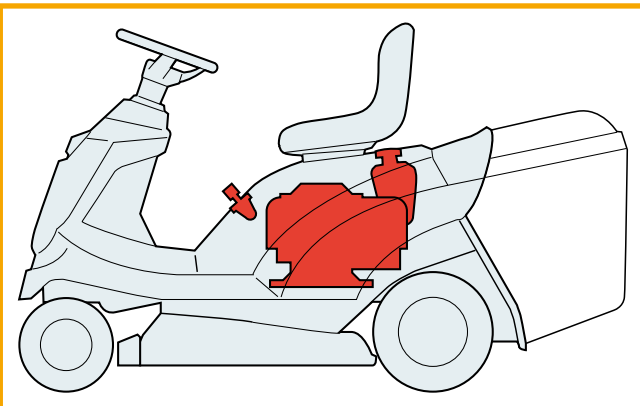

RELATED TOPICS:

Adjustments and tuning

Removal of external parts and main assemblies

Removal of wheels covers..... [👉 5.3]

Removal of the engine..... [👉 5.6]

Repairs

Replacement of the accelerator [👉 6.7]

General informations

The use of outsourced third-party mechanic or hydrostatic drive units is foreseen on this machine.

This manual only describes the operations relating to the application of the machine units; reference to the drive unit's Manufacturer's Manual is recommended for information regarding servicing, disassembly and replacement of components.

Related topics

[👉 1.1] Identification of components

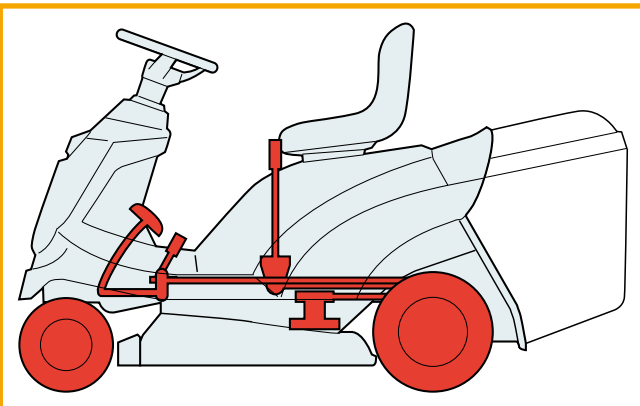

RELATED TOPICS:

Adjustments and tuning

- Brake adjustment [👉 4.3]
- Drive lever adjustment [👉 4.4]
- Drive belt adjustment (➤ *Peerless MST 205-541 E*) [👉 4.11]

Removal of external parts and main assemblies

- Removal of the rear axle (➤ *Peerless MST 205-541 E*) [👉 5.7]
- Removal of the rear axle (➤ *Tuff Torq K46T*) [👉 5.7a]
- Removal of the rear axle (➤ *Hydro-Gear T2-BDBE-2X1A-16X1*) ... [👉 5.7b]

Repairs

- Replacement of tyres and wheels [👉 6.1]
- Replacement of front wheel bearings [👉 6.2]
- Replacement of the drive belt [👉 6.4]
- Replacement of the drive lever unit [👉 6.8]
- Replacement of the lever return cable [👉 6.9]
- Replacement of the friction discs for clutch device [👉 6.10]
- Replacement of the brake pads and disc (➤ *Peerless MST 205-541 E*) .. [👉 6.12]

General informations

The terms "Cutting deck" or "Equipment" refer to the cutting-means assembly, connected to the machine PTO by means of a belt.

Related topics

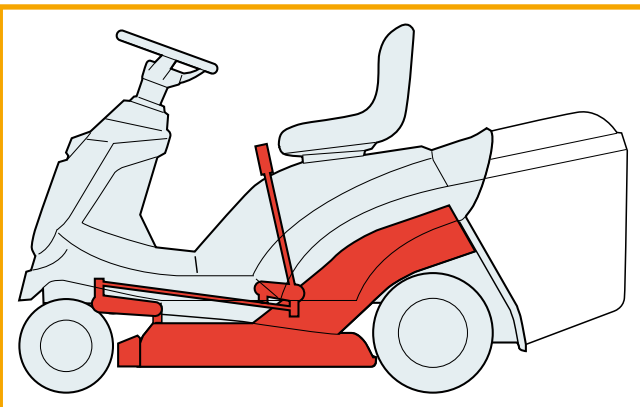

RELATED TOPICS:

Adjustments and tuning

- Blade engagement adjustment [👉 4.1]
- Blade brake adjustment [👉 4.2]
- Aligning the cutting deck [👉 4.5]
- Checking blade alignment [👉 4.8]
- Removing, sharpening and balancing the blade [👉 4.9]
- Adjustment of the collector channel guide..... [👉 4.10]

Removal of external parts and main assemblies

- Removal of the ejection conveyor [👉 5.5]
- Removal of the cutting deck [👉 5.8]

Repairs

- Replacement of the blade belt [👉 6.5]
- Replacement of the support and shaft of the blade [👉 6.6]
- Replacement of the seat's safety cable (with STIGA and Honda GXV390 engines) [👉 6.11]

General informations

Related topics

RELATED TOPICS:

Adjustments and tuning

- Steering allowance adjustment [👉 4.6]
- Steering geometry adjustment [👉 4.7]

Removal of external parts and main assemblies

Repairs

- Replacement of steering components [👉 6.3]

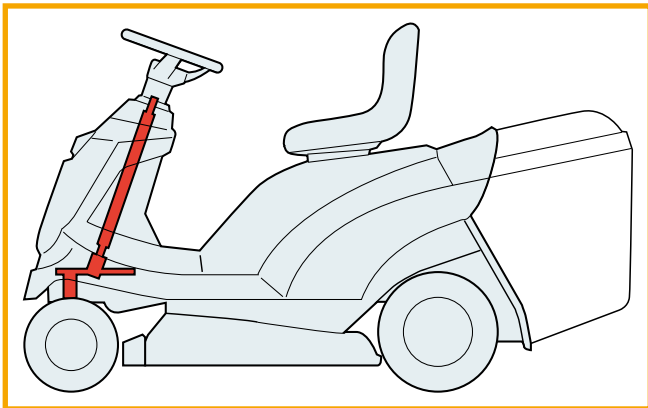

General informations

Different outfittings are foreseen for this machine which can imply the use of different bodywork designs.

The operations described herein are applicable to all versions, except for instructions provided for each specific outfitting.

Related topics

RELATED TOPICS:

Adjustments and tuning

Removal of external parts and main assemblies

- Removal of the steering column protection cover [👉 5.1]
- Removal of the footboard [👉 5.2]
- Removal of wheels covers [👉 5.3]
- Removal of the rear plate [👉 5.4]

Repairs

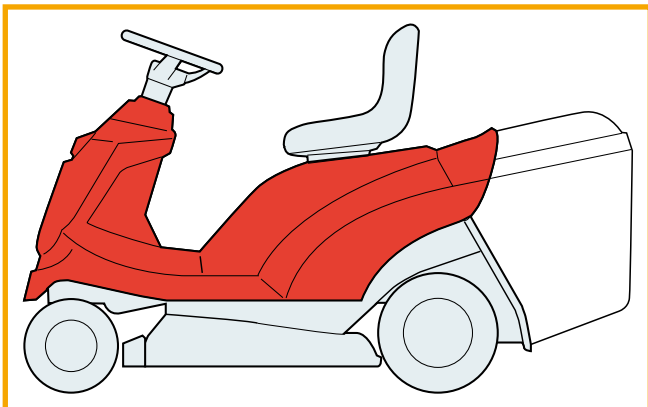

General informations

Related topics

RELATED TOPICS:

Information and Verifications

Troubleshooting of the electrical system [👉 7.1]
 Cutting in of the safety devices [👉 7.2]
 Safety microswitches operation check [👉 7.3]
 Terminal board supply check [👉 7.4]
 Starter relay and carburettor solenoid valve operation check [👉 7.5]
 Electronic card operation check [👉 7.6]
 Recharge circuit check [👉 7.7]
 Maintenance of the sealed battery [👉 7.8]
 Fitting safety microswitches [👉 7.9]
 Electrical diagrams [👉 7.10]

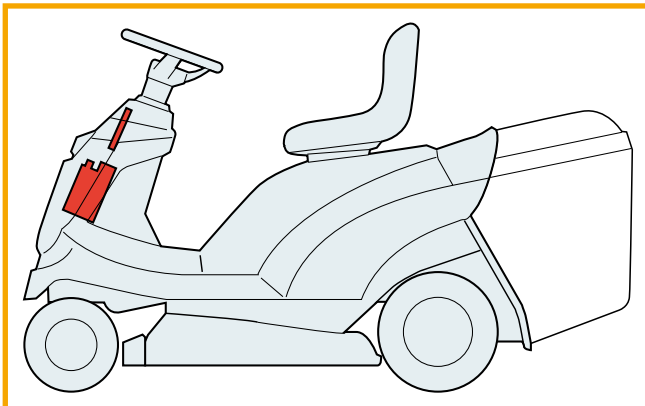

General informations

This chapter covers all the main aspects of the relationship between the Manufacturer and the Service Centres.

A close collaboration between the Manufacturer and the Service Centres is conclusive for solving problems in the most effective way as well as maintaining an image of efficiency and reliability. Compliance with these brief and simple guidelines will facilitate this task and prevent general misunderstandings and time-wasting for both the manufacturer and the service centre.

Related topics

Map of functional units

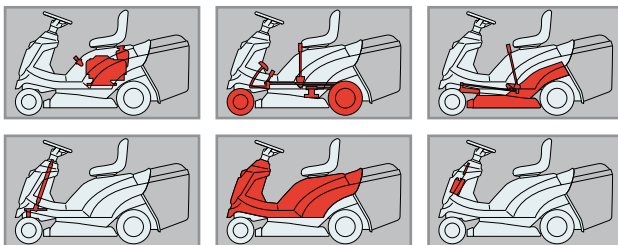

A) Identification

1) Machine

Each machine has a label attached (1) under the driver's seat which shows the technical specifications, the model and the serial number..

The model and serial number must be shown on each repair sheet when requests are made under guarantee, and are indispensable for spare part orders.

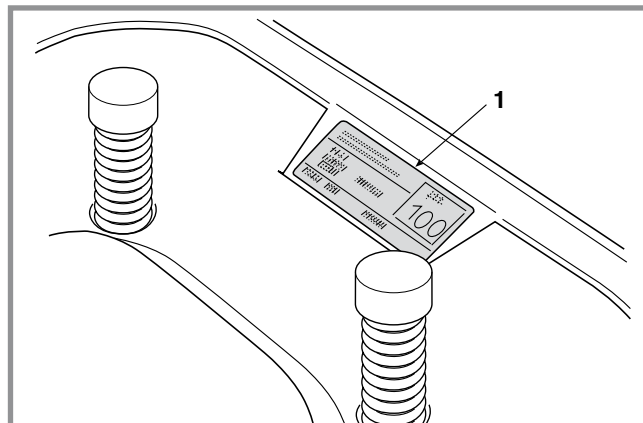

2) Transmission

The transmission unit (both mechanical and hydrostatic) is made up of an engine block including the rear axle.

This unit is made by another manufacturer to our precise technical specifications which differentiate it from similar items by this same Manufacturer.

The serial number on the label (2) clearly identifies the product and its specifications. This

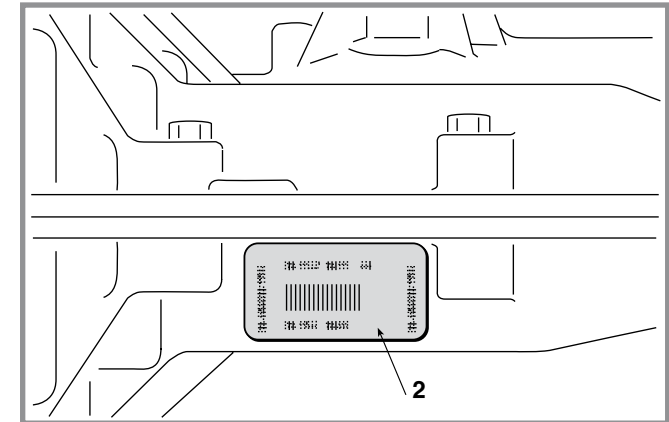

number must always be quoted when requesting spare parts or any information from the Manufacturer.

3) Engine

The engine is made to precise technical specifications which differentiate it from similar items by this same Manufacturer.

The serial number on the label clearly identifies the product and its specifications. This number must always be quoted when requesting spare parts or any information from the Manufacturer.

B) Guarantee validity

The guarantee is supplied under the terms and the limits of the contractual relations in being. As far as the engine and the transmission unit are concerned, the conditions given by their respective manufacturers apply.

C) Service repairs after guarantee period

The Service Centre has to make out a report containing the machine's serial number, a summary of the problem, the repairs carried out and any spare parts used for each repair done on the machine.

A copy of this report must be retained to be made available to the Manufacturer together with the parts in case of any subsequent disputes with Customers.

D) Fault notification

The Manufacturer welcomes any notifications of faults that recur with particular frequency. It gives the opportunity for a careful inspection of the problem and the implementation of corrective action at production level.

Similarly, the Manufacturer will notify of any faults discovered on the machines produced, with recommendations for the most suitable procedures for their remedy.

E) Spare parts request

When requesting spare parts, the code number must be given, referring to the exploded charts for the year of manufacture, shown on the identification label.

General informations

This chapter covers the main aspects of a servicing procedure and the general rules for guaranteeing a successful service which respects the safety of the machine.

Related topics

 **2.2** Tools

 **7.3** Safety microswitches operation check

Map of functional units

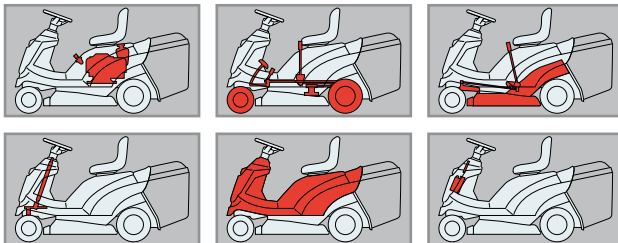

SAFETY REGULATIONS

A) Qualification of operators

All maintenance, disassembly and repairs must be carried out by expert mechanics who are familiar with all the accident prevention and safety regulations after reading through the procedures in this manual.

B) Safety measures

All the machines are manufactured in accordance with the strict European safety regulations in force.

To maintain these levels of safety in the longer term, the Service Centres should work to this end by making appropriate checks every time there is the chance to do so.

Particularly, every time there is work done on the machine the Service Centre should:

1) check:

- that safety microswitches are working correctly;
- that the casings and protection covers have not been removed;
- that the labels with instructions or provisions have not been removed or have become illegible (these form an integral part of the safety system).

2) they should also:

- restore to proper working order any safety devices which have been manipulated or removed;
- reattach inefficient, damaged or missing casings and protection covers;
- replace illegible labels;

CHAPTER	REVISION	FROM ...	PAGE
2.1	1	2018	1 of 2

- not endorse any repair or modification on the machine or the engine which results in a change in performance or use that is incorrect or different from the purpose for which it was designed and approved;
- warn the Customer that the failure to comply with the above points results in the automatic annulment of the Guarantee and the Manufacturer declines all responsibility, as also shown in the Instruction Booklet.

C) Precautions during servicing

The operations described in this manual do not entail particularly hazardous situations besides the normal hazard related to mechanical operations and that can be avoided by taking the necessary care and attention normally required for this type of work.

As well as following the usual accident prevention regulations that apply to most repair shops, we recommend you:

- taking out the ignition key before beginning any repair work.
- protect hands with suitable working gloves, especially when working near the cutting unit;
- check that you do not cause accidental petrol leaks or other losses;
- do not smoke when working on the tank or when handling petrol;
- do not inhale oil or petrol fumes;
- clean up all traces of spilt petrol immediately;
- test the engine in a well-ventilated environment or where there are adequate exhaust fume extraction systems;
- do not pollute the environment with oil, petrol or other waste and dispose of all waste in accordance with the laws in force;

- ensure that other persons cannot accidentally carry out actions that may physically endanger those working on the machine.

D) Necessary equipment

All the operations can be carried out with the tools normally used in a good garage.

Some operations require special equipment and tools.

TOOLS

General informations

This chapter covers the main aspects of a servicing procedure and the general rules for guaranteeing a successful service which respects the safety of the machine.

Related topics

Map of functional units

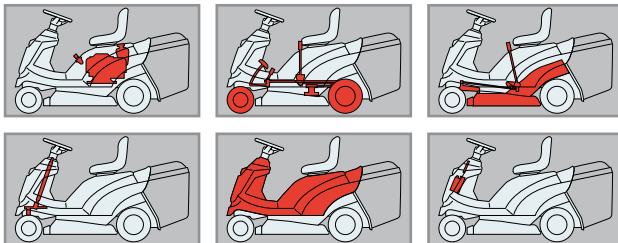

All work can be carried out using the tools normally available from a good workshop. However, it is advisable to have a set of special tools.

These tools are to be used whenever is given in the text.

1. Blocks H = 26 mm for adjusting the cutting deck
2. Blocks H = 32 mm for adjusting the cutting deck
3. Bush for assembly of blade bearings
4. Stopper for assembly of wheel bearings
5. Pulley extractor

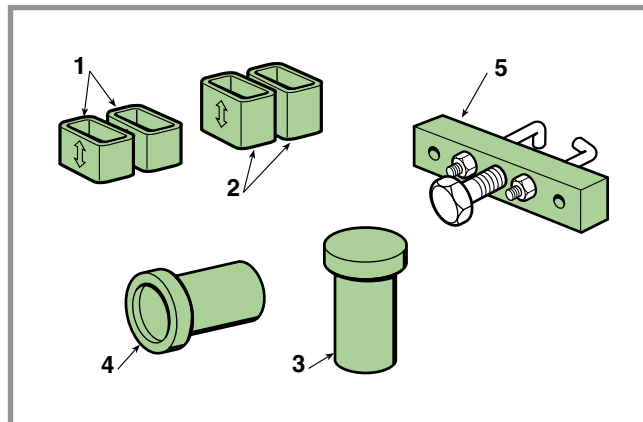

LIFTING

CHAPTER	REVISION	FROM ...	PAGE
2.3	0	2018	1 of 1

General informations

This chapter covers the main aspects of a servicing procedure and the general rules for guaranteeing a successful service which respects the safety of the machine.

Related topics

Map of functional units

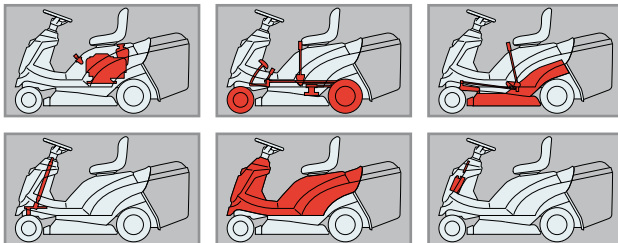

! DANGER! *The machine must never be lifted using a hoist or other lifting equipment which uses cables.*

A) Front

Once the parking brake has been engaged, the machine can be lifted using a jack which pushes on the underside of the frame, placing a wood block (1) between the base of the jack and the frame and checking to see that the free movement of the front spring equaliser has not been obstructed.

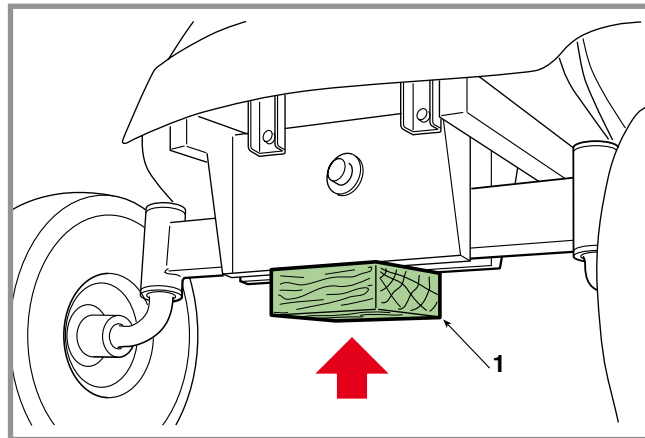

B) Rear

Position two suitably sized wedges (3) in front of the front wheels to prevent all uncontrolled movement of the machine.

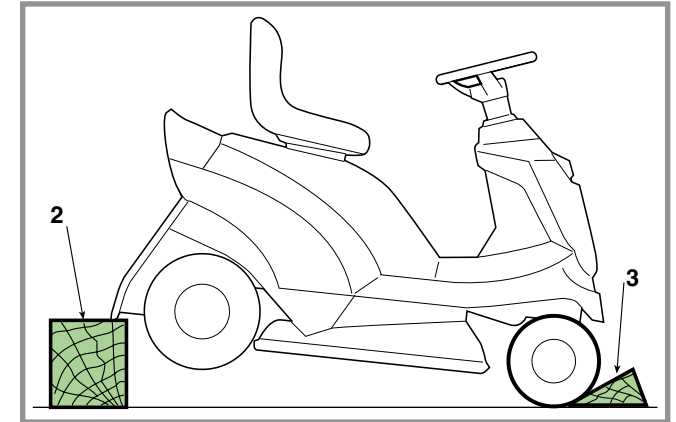

Position a jack under the transmission unit and lift it enough to place two suitable blocks (2) beneath the lower edge of the rear plate.

Release the jack and make sure the machine is stable before starting any work.

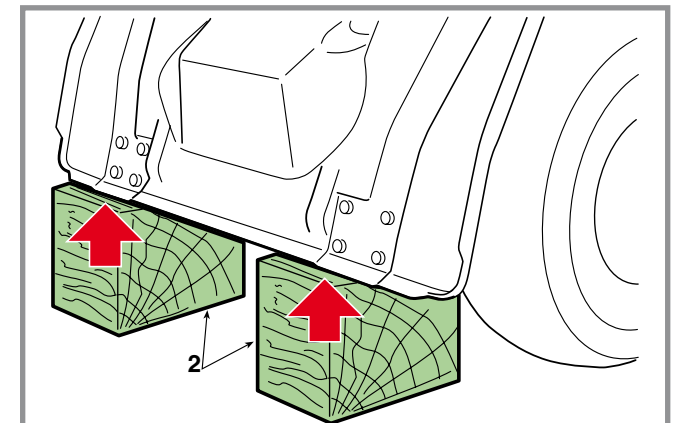

PLACING THE MACHINE ON ITS SIDE

General informations

This chapter covers the main aspects of a servicing procedure and the general rules for guaranteeing a successful service which respects the safety of the machine.

Related topics

Map of functional units

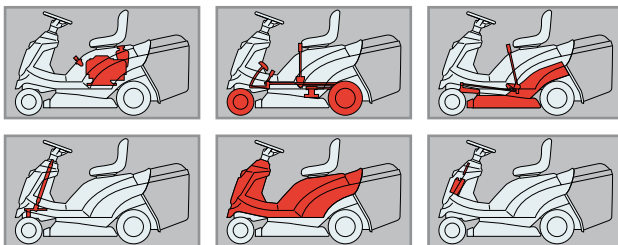

⚠ WARNING! *Two people will be needed for this work. When moving the machine onto its side it should only be gripped at strong parts (steering wheel, seat, frame, etc.) and NEVER by the plastic parts of the body.*

The fuel tank must be totally emptied before placing the machine on its side.

Put the machine onto a flat and firm surface, remove the grass-catcher, engage the parking brake and raise the cutting deck to its maximum height.

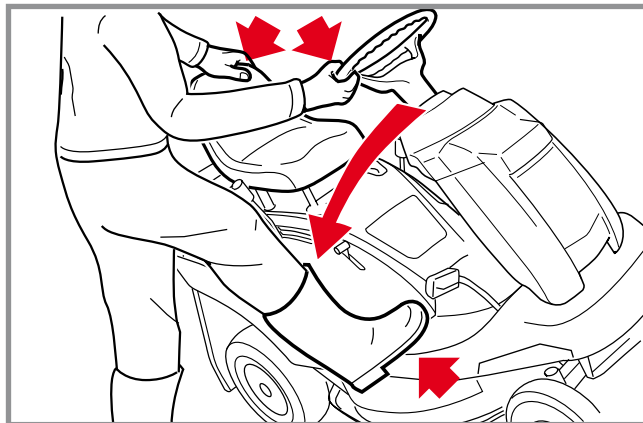
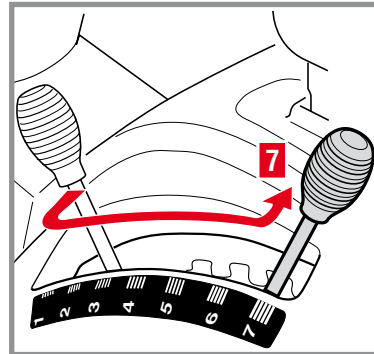

Firmly grip the steering wheel and the seat and tip the machine over until it is resting on the grass-catcher, taking care not to damage the body's plastic parts.

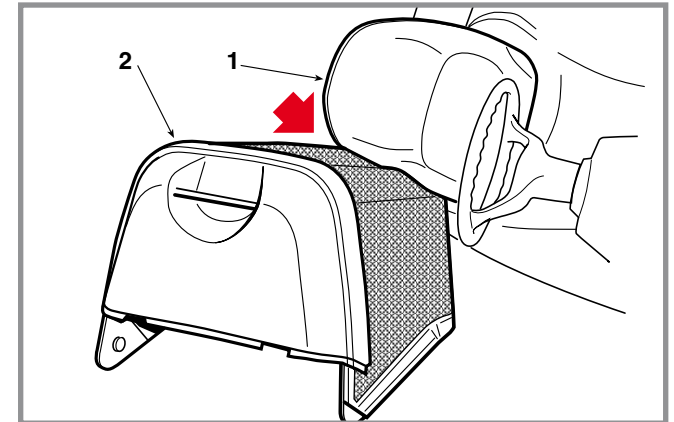

The machine must only be laid on its right hand side, resting the seat (1) and one of the corners of the grass-catcher (2) as shown.

⚠ WARNING! *Before carrying out any type of work make sure that the machine is completely stable, and avoid operations that could cause it to fall over.*

⚠ WARNING! *Be just as careful when putting the machine back on a flat surface; two people are needed for this operation..*

OPENING THE WHEEL COVER

CHAPTER	REVISION	FROM ...	PAGE
2.5	2	2018	1 of 2

General informations

The engine and the mechanical units can be reached by turning back the wheel cover. There are specific indications for opening the cover which are shown below and also in the instruction handbook.

Related topics

[\[4.10 \]](#) Adjustment of the collector channel guide

Map of functional units

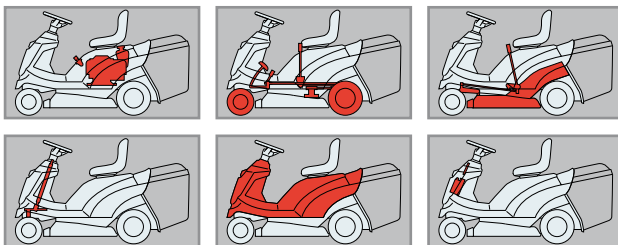

Remove the grass-catcher or stoneguard and move the machine to a flat floor.

Raise the cutting deck to its maximum height.

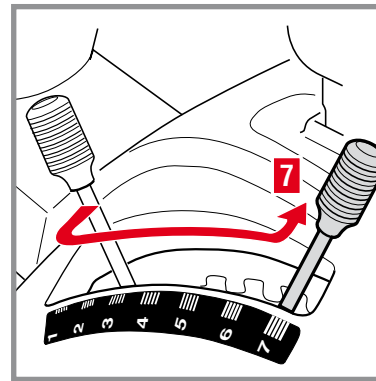

► **mechanical drive models**

- Engage the parking brake.
- Put the lever (3) into position «N».

► **hydrostatic drive models**

- Put the drive release lever in the «ENGAGED» position. This is because the parking brake needs to be disengaged to ensure the necessary movement to the speed lever.

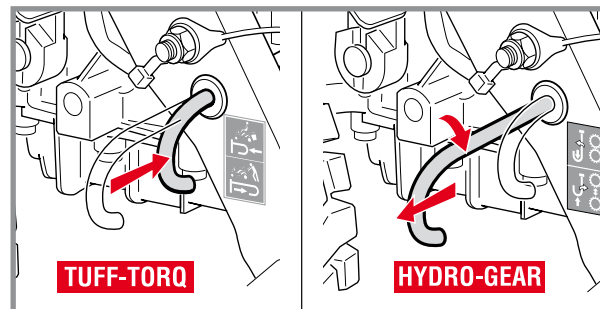

- Put the lever (3) into position «R».

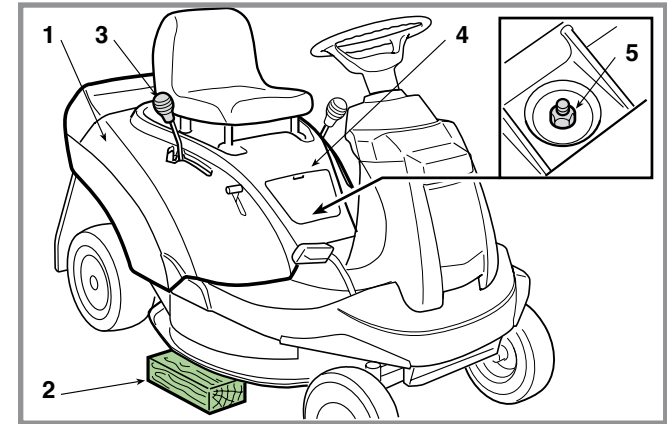

Unscrew the knob on the lever (3).

Place blocks (2) of about 65 – 70 mm beneath its edge in order to support the deck during subsequent operations.

Open the access hatch (4) and unscrew the nut (5) with a 13 mm spanner.

Release the lever (6) so that the deck rests on the blocks, and keep it held to the side so that it does not slip into any of the notches. Grip the base of the seat (7) and turn back the cover (1).

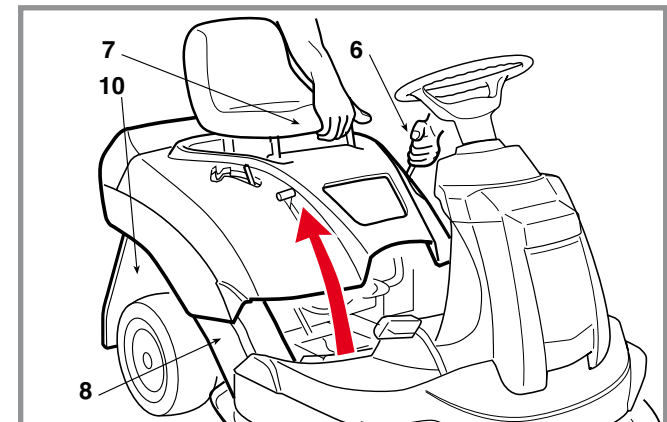

OPENING THE WHEEL COVER

CHAPTER	REVISION	FROM ...	PAGE
2.5	2	2018	2 of 2

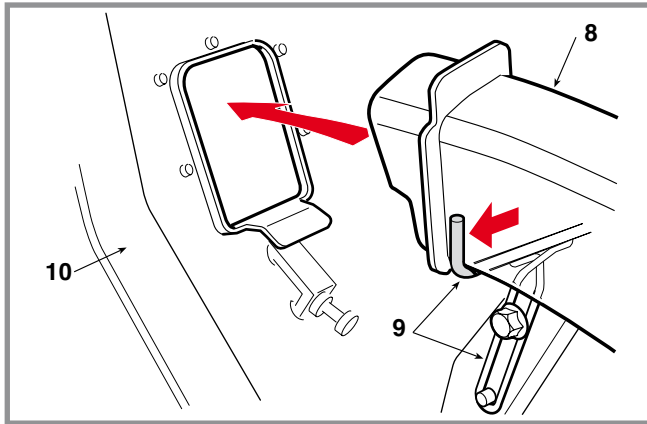

When closing, make sure that the channel (8) is properly fitted onto the support (9) and resting on the right-hand guide. Put the lever (3) into position «R» and lower the cover (1) at the level of the levers (3) and (6).

First put the lever (6) into its housing, and then lever (3), lower the cover until it centres on the fixing screw.

If this has been done correctly and the guide (9) is properly positioned, the opening of the channel will easily slip into the hole in the plate (10) without any need to guide it in manually.

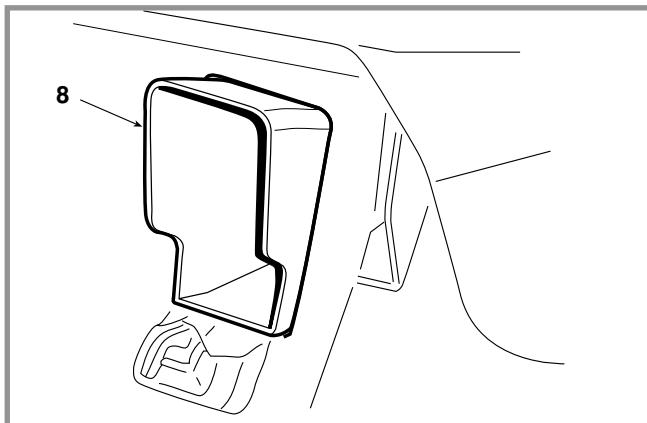

If it does not enter easily and correctly,

☛ Adjust the insertion guide.

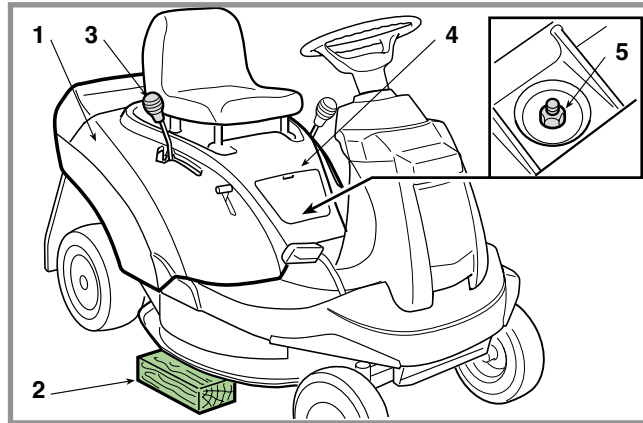

Fully tighten the nut (5), put the lever (6) in position «7» engaging it in the stop notch, and remove the blocks (2). Then refit the lever knob (3) and the hatch (4).

PRACTICAL HINTS

CHAPTER	REVISION	FROM ...	PAGE
2.6	0	2018	1 of 2

General informations

This chapter covers the main aspects of a servicing procedure and the general rules for guaranteeing a successful service which respects the safety of the machine.

Related topics

Map of functional units

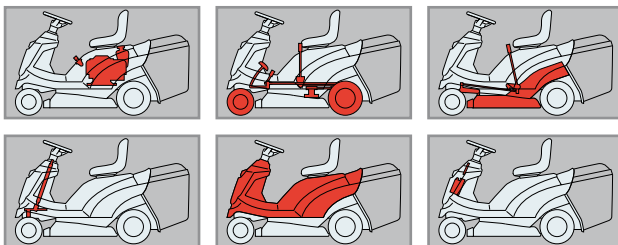

A) Fitting snap rings

One side of the “Benzing” snap rings (1) has a rounded edge and the other a sharp edge.

For maximum grip the rounded part needs to be facing towards the element to be held (2), with the sharp edges on the outside.

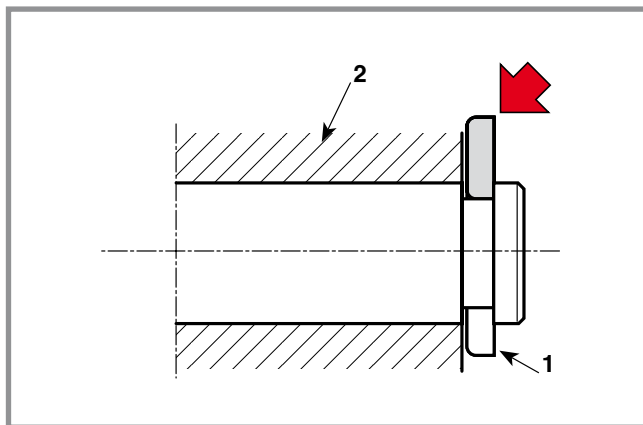
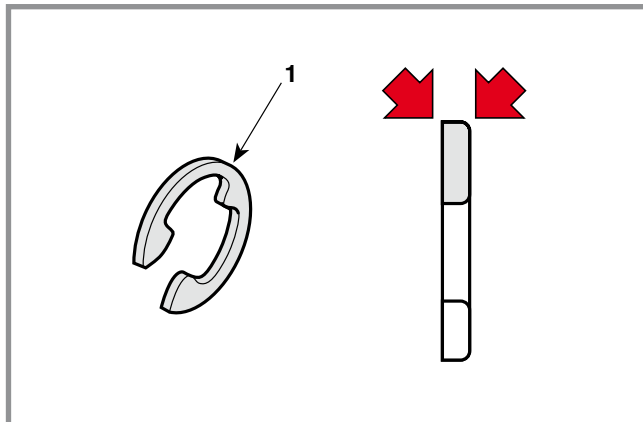

B) Joint pivot pins

There are a large number of pivot pins, usually connected to rods, that need to be able to move in various directions.

A typical situation has the pin (3) fixed by a self-locking nut (4) with two anti-friction washers (5) in between the pin (3) and the support element, and between this and the nut (4).

Since these are joints, the nut must never be tightened completely but only so much that it can ensure the free rotational movement of the pin on its axis without, however, creating excessive free play which could result in the parts concerned becoming misaligned and failing to work correctly.

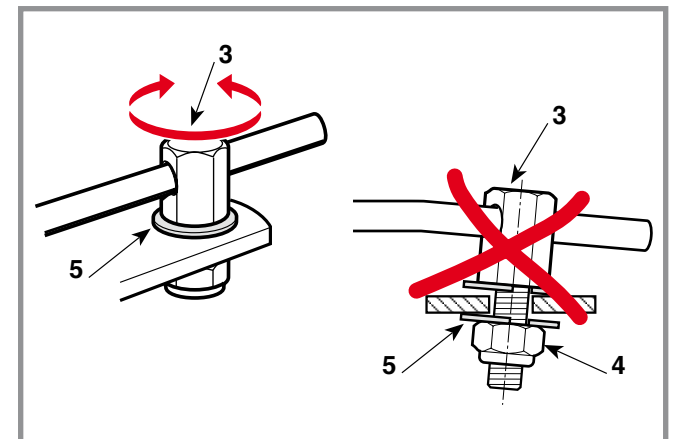
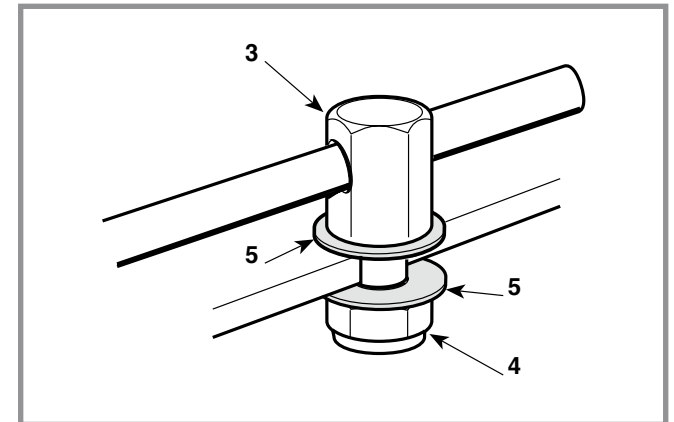

C) Crown fasteners

Some pin ends (6) are secured by crown fasteners (7). During dismantling, these fasteners are always damaged and lose their hold, so they should never be reused.

On assembly, make sure it is inserted in the right direction and push the fastener (7) onto the pin using a pipe or socket spanner (8) with the right diameter, so that it can be fitted without deforming the fastener "crown".

IMPORTANT A deformed fastener should always be replaced.

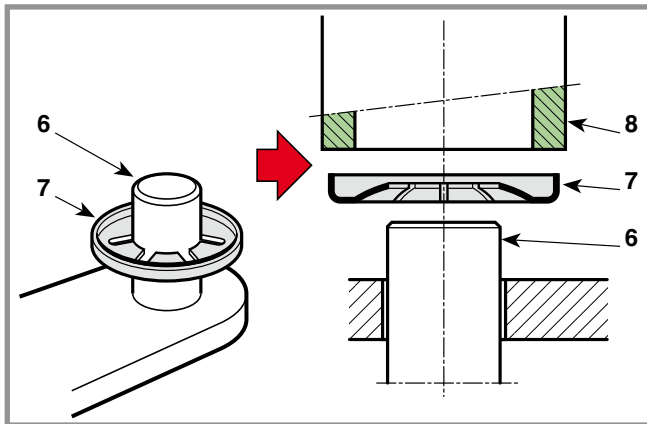

General informations

In questo capitolo vengono trattati i criteri di intervento per la manutenzione ordinaria.

Related topics

Map of functional units

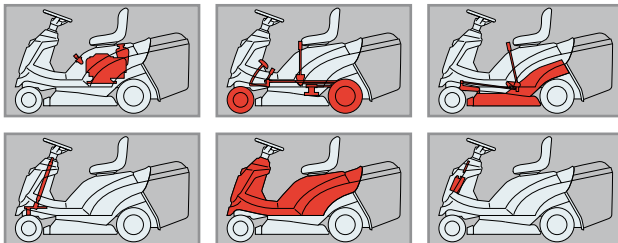

The Instruction Handbook has a number of operations to be carried out by the Customer for a minimum of basic maintenance, and other operations not always within his capacity.

For this reason the Service Centre should undertake to keep the machine in perfect working order in two ways:

- Tuning the machine whenever possible.
- Proposing a regular maintenance programme to the Customer to be carried out at prearranged intervals (for example, at the end of the summer or prior to a long period of inactivity).

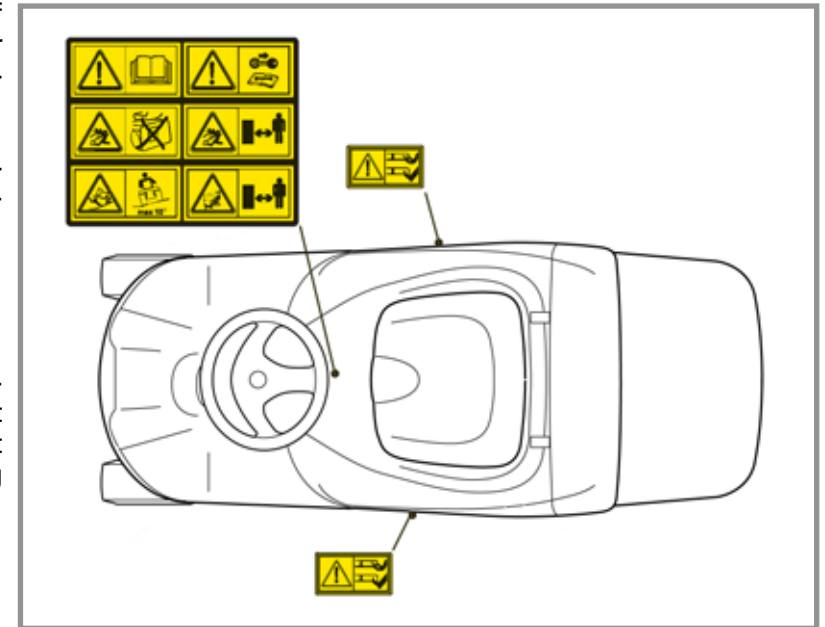

A) Occasional tuning

- Check working order of safety devices and renew illegible or missing labels, following the layout below
- Check tyre pressures
- Clean air filter
- Check engine oil level
- Check for fuel leaks
- Aligning the cutting deck
- Sharpen and balance the blade and check the condition of the hub
- Check for wear in the belts
- Check the blade brake engagement
- Grease front wheels lever joint pins and bushes
- Grease the bush of the drive lever
- Check tightness of engine screws
- Check all those items indicated in the engine manual

B) Routine maintenance

- All work carried out in section a), plus:
- Check battery charge
- Check tension of belts
- Adjust brake
- Adjust blade engagement
- Adjust blade brake
- Check steering allowance
- Check front bearings
- General lubrication
- Clean away grass cuttings and wash exterior
- Clean and wash inside cutting deck and collector channel
- Clean and wash grass-catcher
- Touching up of any damaged paint

General informations

This chapter helps achieve a rapid identification and solution to the most recurrent problems, classified according to the operating unit in question.

Related topics

Map of functional units

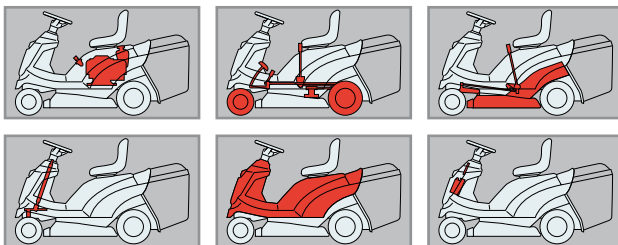

1. Engine and Tank

Problem	Probable cause	Solution	
Starter motor does not run	Low battery	Recharge	[7.8]
	No starter relay contact	Check	[7.5]
	Faulty connector and/or starter motor failure	Check and/or replace	[*]
The starter motor runs but the engine does not start	Blown spark plug electrode	Replace the spark plugs	[*]
	Uncertain connections	Check the connectors	-
	Coil failure	Check and/or replace	[*]
	The carburettor solenoid valve does not open	Check	[*]
The engine runs irregularly and/or lacks power	No fuel is pumped to the carburettor	Check the filter, fuel pump (if applicable) and the carburettor	[*]
	Faulty ignition	Check the spark plugs and ignition system	[*]
Dense and/or blue exhaust fumes	Low fuel level in the tank	Top up	-
	Dirty or old fuel	Empty the fuel tank and add fresh fuel	-
	Clogged carburettor filter	Check and clean	[*]
Black exhaust fumes	Excessively oily carburetion	Check the starter and command cable	[*]
Engine overheating	Spark plug with inadequate heat rating	Check	[*]
	Carburetion problems	Check the carburettor	[*]
	Insufficient oil level	Check and top up	[*]
	Clogged suction system	Check and clean the air filter and the suction pipe	[*]
	Dirty cooling flaps	Clean	[*]
Engine idling speed is too high or too low.	Broken cooling fan	Replace	[*]
	Incorrect cable adjustment	Adjust	[6.7]
Abnormal noise and vibrations	Loose bolts and screws	Check and tighten to the prescribed values	[5.6]

[*] Check the engine Manufacturer's Manual

Important informations

Characteristics of the original belts

The standard belts on the market have different characteristics compared to the requirements of the original spare belts, supplied by the authorised dealer. The latter are designed and manufactured in close cooperation with the belt supplier and the machine manufacturer.

Here are the reasons why it is important to choose an original belt, useful when making such decisions..

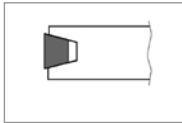

a) Adhesion on the pulley. The belt rests with the sides inclined against the walls of the pulley. There must be a gap between the belt and the bottom of the groove.

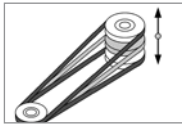

b) Floating pulley on cutting equipment. The original Power Take Off (PTO) belt is designed to work even if the pulleys move up and down and tilt at the same time.

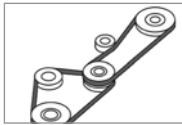

c) Curvature in two directions. All the original belts, which work with tensioning arms acting on the external side, are equipped with reinforcements. The reinforcement is designed specifically for these specific cases..

2. Transmission - Brakes - Wheels

Problem	Probable cause	Solution	
The machine moves slowly, loses power or doesn't move at all	Worn or oily belt	Replace	[6.4]
	Broken pulleys	Replace	[5.6] [*]
	The brake is not adjusted correctly	Check and adjust	[4.3]
	Transmission unit failure	Check the Manufacturer's Instruction Manual.	[*]
The machine will not move in either direction	Pulley splines broken	Replace	[*]
	Transmission unit failure	Check the Manufacturer's Instruction Manual.	[*]
The machine does not reach the foreseen speed in forward drive	Incorrect lever adjustment	Adjust	[4.4]
Uncertain or ineffective braking	The brake is not adjusted correctly	Check and adjust	[4.3]
Abnormal noise and vibrations	Slack or worn belt	Check and/or replace	[6.4]
	Irregular fan rotation	Check the condition of the fan, that it is securely fastened in place and that nothing interferes with the rotation movement	[*]
	Incorrect positioning of the by-pass valve ¹⁾	Check and adjust	[*]
	Loose bolts and screws	Check and tighten to the prescribed values	[5.7] [5.7a] [5.7b]
The machine moves in neutral gear	Incorrect micro-switch adjustment ¹⁾	Adjust	[4.4]
	Slack or worn linkage system	Check and/or replace	[4.4]
Pushing the machine by hand is difficult ¹⁾	By-pass partially enabled ¹⁾	Check	[*]
The parking brake does not stop the machine on a 30% slope	Incorrect brake adjustment	Adjust	[4.3]
Excessive clearance on the front wheels	Worn bearings	Replace	[6.2]

¹⁾ Only for hydrostatic drive models

[*] Check the transmission unit Manufacturer's Instruction Manual.

Important informations

Characteristics of the original blades

The original blades have design, material and processing characteristics optimised for use on the equipment for which they were designed; these characteristics are not present in so-called “compatible” spare parts.

Here are the reasons why it is important to choose an original blade, useful when making such decisions.



a) No breakage of the blade ends. Using steel balls, the manufacturer simulates what can happen when mowing over any foreign

bodies on the lawn. This can ruin the blade edge, but no component can come loose, fall off or be hurled away.



b) No breakage of the blades. The impact test is the most severe durability test that any lawnmower can be subjected to. An iron tube is

placed exactly inside the blades when the mower is running. The blade may deform but it will never, under any circumstances, fall off or break. This test verifies that blades and other components meet the high safety requirements.

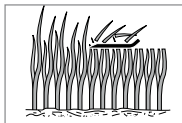

c) Excellent cutting result. The blades and blade ends supplied by the authorised dealer are optimised for the application for which

they are intended. In short, this means that the blades are suitable for the shape of the casing and to the number of revolutions to provide the best possible cutting result.

3. Cutting deck

Problem	Probable cause	Solution	
The blade does not engage	Slack belt	Adjust the engagement	[4.1]
	Incorrect adjustment of the engagement spring	Adjust the engagement	[4.1]
The blade does not stop promptly within 5 seconds when it is disengaged	The blade brake is not adjusted correctly	Check and adjust	[4.2]
Uneven mowing	Cutting deck not parallel to the ground	Check the tyre pressures Align the cutting deck with the ground	[6.1] [4.5]
	Blade cutting badly	Check their condition and that it is well sharpened	[4.9]
	Misaligned blade	Check the blade shaft and flange	[4.8]
Abnormal noise or vibrations	Loose joint bolts and screws	Check and adjust	[5.8]
	Pulleys or guide pulleys are worn and do not rotate correctly	Check and/or replace	-

4. Steering

Problem	Probable cause	Solution	
Excessive clearance on the steering wheel	Worn pinion and crown teeth	Adjust and/or replace	[4.6] [6.3]
The machine does not maintain a straight line when the steering wheel is straight	Incorrect tie-rod adjustment	Adjust	[4.7]

General informations

The blade is run from the engine using a «V» belt and is engaged by a stretcher worked from the lever.

After a certain amount of use the belt can become longer which can result in malfunctioning, i.e.:

- belt slipping = belt stretched
 - difficulty in disengaging, with a stiff lever and the blade continuing to run = belt shortened
- In both cases the stretcher needs to be adjusted.

Related topics

[\[🔧 4.2\]](#) Blade brake adjustment

[\[🔧 6.5\]](#) Replacement of the blade belt

Map of functional units

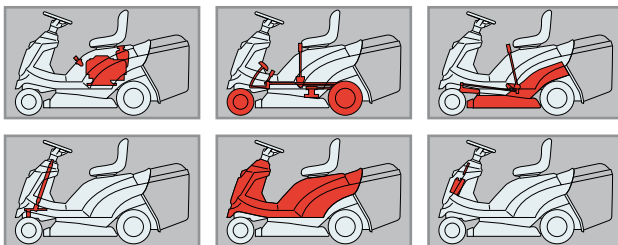

Remove left side belt guard

The length of the spring (1) must be adjusted with the blade engaged and the cutting deck in position «1», because in other positions the length can vary considerably.

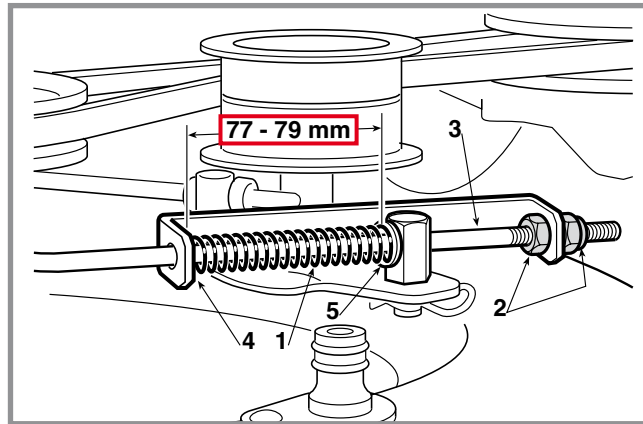

Loosen the nuts (2) and screw or unscrew them on the control rod (3) in order to obtain a distance of 77-79 mm between the bracket (4) and the inside of the washer (5).

When the adjustment has been made, screw the nuts (2) back on.

! When the blade engagement has been adjusted it is always advisable to ...
 🔧 Check that the blade brake is working correctly.

! **WARNING!** Reassemble left side belt guard.

BLADE BRAKE ADJUSTMENT

CHAPTER	REVISION	FROM ...	PAGE
4.2	1	2018	1 of 1

General informations

The blade has a brake which stops rotation within five seconds:

- when the blade disengages
- when the operator gets out of the seat without disengaging the blade.

Longer braking times do not comply with safety regulations, but adjusting the brake so that it stops quicker than this can cause the belt to slip on the shoe resulting in overheating with the typical smell of burnt rubber.

Related topics

- [🔧 2.5] Opening the wheel cover
- [🔧 5.1] Removal of the steering column protection cover
- [🔧 5.5] Removal of the collector channel

Map of functional units

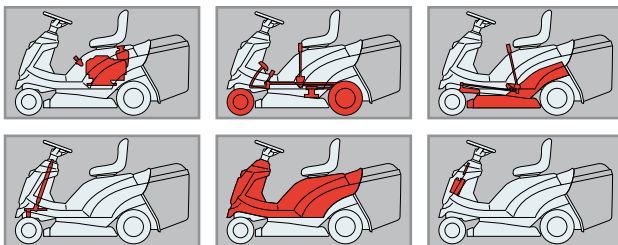

A) Adjustment of the brake after disengaging the blade

The braking power on the blade belt is generated by the spring (1) which catches the blade engagement lever (2) after disengagement. In order to use all the braking power, do not allow the lever to reach its end of travel in relation to the guide shoe (3).

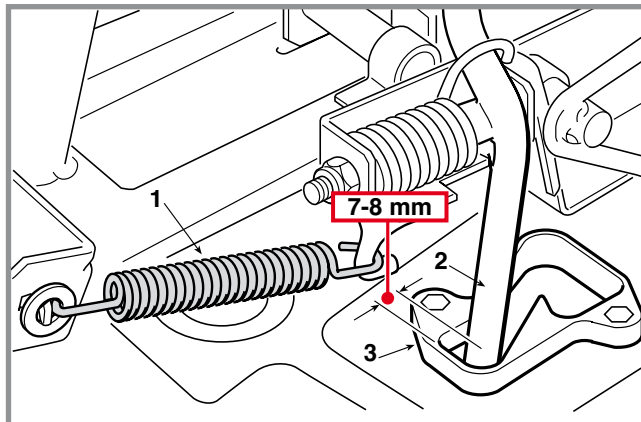

Check that the brake shoe (4) is not deformed.

- 🔧 Remove the steering column cover.

Disengage the blade and check that the lever (2) and guide shoe (3) have a clearance of at least 7-8 mm.

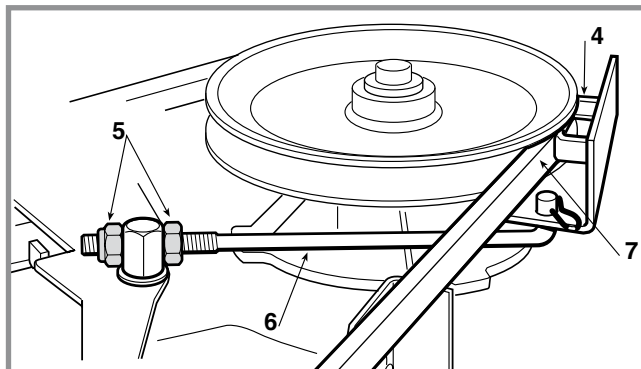

If this is not so, adjust the nuts (5) on the tie-rod (6) until you achieve this clearance.

- 🔧 Reassembly the steering column cover.

B) Adjustment of the brake after the operator gets out of the seat (models with STIGA and Honda GXV390 engine only)

- 🔧 Lift the wheels cover.
- 🔧 Remove the collector channel.

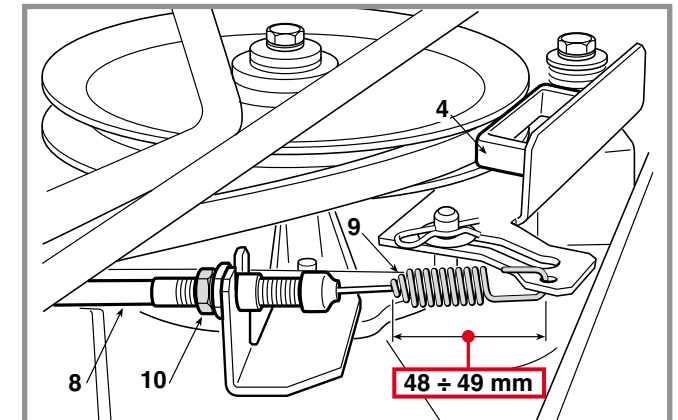

The braking force on the blade belt is generated by the return spring on the seat, which acts on the brake shoe (4) via the cable (8) and the spring (9).

After making the adjustment indicated in point "A", regulate the adjuster (10) until the spring (9) is 48 - 49 mm long with the blade disengaged.

- 🔧 Reattach the collector channel.
- 🔧 Close up the wheels cover.

⚠️ WARNING! After adjustment, disengaging the blade or getting out of the seat, the brake shoe (4) should press adequately against the belt (7) and stop rotation within 5 seconds of disengagement.

BRAKE ADJUSTMENT

CHAPTER	REVISION	FROM ...	PAGE
4.3	2	2018	1 of 2

General informations

Reduced braking power is corrected by adjusting the spring on the brake rod which can be reached after having lifted the wheels cover.

Related topics

[🔧 1.1] Identification of transmission unit

[🔧 2.5] Opening the wheel cover

[🔧 6.12] Replacement of the brake pads and disc (Peerless MST 205-541 E)

Map of functional units

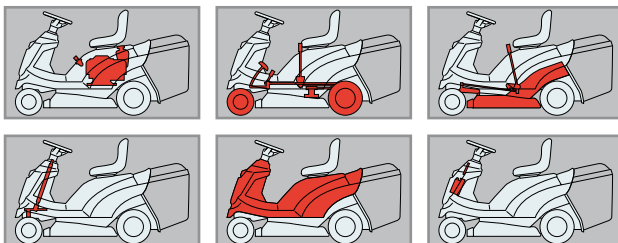

🔧 Lift the wheels cover

The adjustment is to be made with the parking brake engaged and consists of altering the length of the spring to the best measurement. The braking capacity is increased by screwing the nut down on the rod (and thus shortening the length of the spring).

NOTE Never go below the indicated values to avoid overloading the brake unit.

Adjust as indicated for each type of transmission.

⚠ WARNING! When the adjustments have been made, the parking brake should prevent the machine from moving on a slope of 30% (16°) with the driver in position.

🔧 Close up the wheels cover

➤ **for Peerless MST 205-541 E drive models:**

Loosen the nut (1) which retains the bracket (2) and then turn the nut (3) until the spring (4) is 46 - 48 mm long, measured from the inside of the washers.

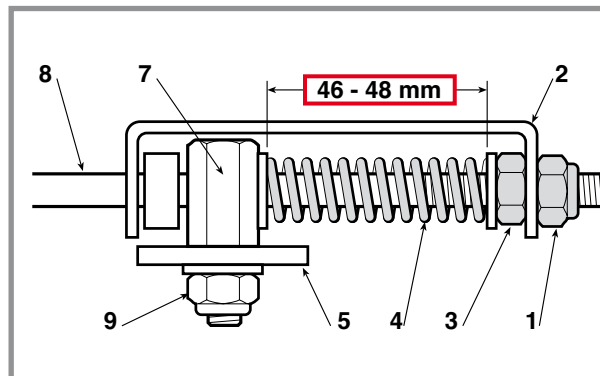

When the adjustment has been made, tighten the nut (1).

⚠ If braking is still poor or uneven even after having made the adjustment, uncouple the pin (7) of the control rod (8) from the lever (5) uncouple the control rod (8) pin (7) or from the lever (5) while the pedal is fully released, and then check that this lever has a free movement of 12 mm before beginning the braking action.

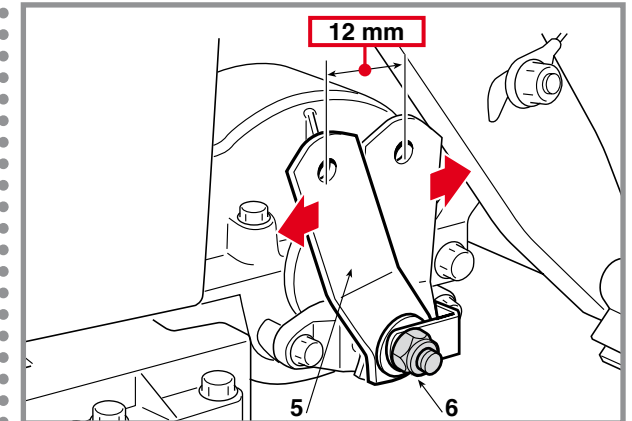

If this is not the case, it is possible to adjust the free movement at the nut (6), unless the brake pads or disc are so worn that they need replacing.

Refit the pin (7) with the control rod (8) and fully tighten the nut (9); then recheck the length of the spring (4).

BRAKE ADJUSTMENT

► for Tuff Torq K46T drive models:

Turn the nut (10) so that the spring (11) is 45 - 47 mm long, measured from the inside of the washers.

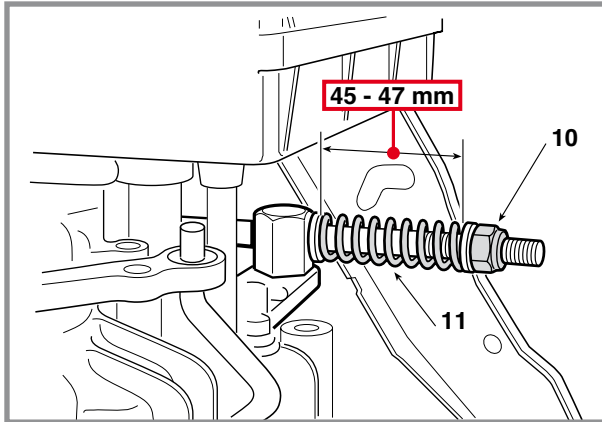

NOTE No other adjustments to the brake system are required.

► for Hydro Gear T2-BDBE-2X1A-16X1 drive models:

Loosen the nut (21) and then turn the nut (22) so that the length of the spring (23) is 34-36 mm measured from the inside of the washers.

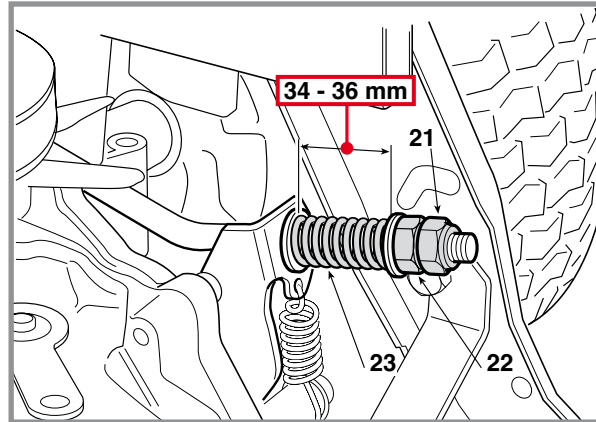

NOTE No other adjustments to the brake system are required.

DRIVE LEVER ADJUSTMENT

General informations:

This adjustment should be made every time work is done on the drive lever unit or when the pedal shaft, back axle or the lever return cable are dismantled.

The main indicators that it is not working properly are:

- the lever does not return when the pedal is pressed = cable loose,
- the lever does not go the full distance, reducing performance = cable too tight,
- the lever is stiff = the spring for the clutch device is badly adjusted,
- the lever is too loose and, under pressure, does not stay in position = the spring for the clutch device is badly adjusted or there is oil on the friction disc,
- the machine has a tendency to move when the lever is in "neutral" = the connection rod is incorrectly adjusted.

Related topics

- [🔧 2.5] Opening the wheel cover
- [🔧 5.5] Removal of the collector channel
- [🔧 6.1] Removal of the wheels
- [🔧 6.10] Replacement of the friction discs

Tightening torques

24 Nuts levers stop hook 8 ÷ 11 Nm

Map of functional units

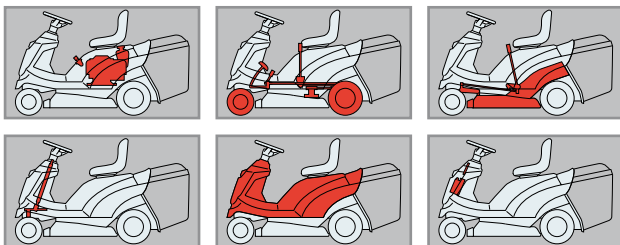

► **mechanical drive models:**

NOTE There is no adjustment of the drive lever.

Adjusting the "neutral" position

- 🔧 Remove the right-hand rear wheel.
- 🔧 Remove the collector channel.

The pedal position is to be adjusted starting with the lever (1) or (1a) of the hydrostatic unit in the "neutral" position.

► **for Tuff Torq K46T drive models:**

Keep the lever (1) in the "neutral" position; this position «N» can be easily recognised as it is forced to stay there by a fastening sphere.

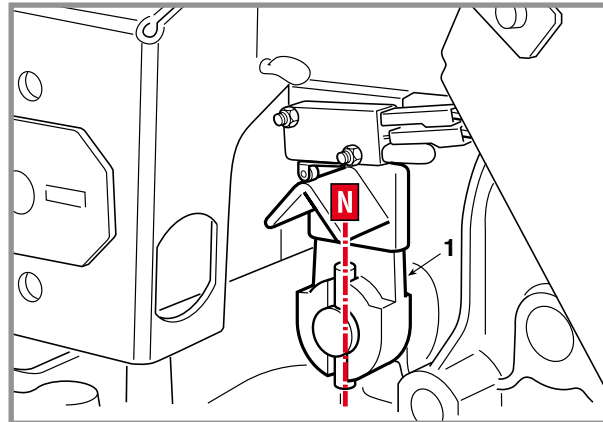

► **for Hydro Gear T2-BDBE-2X1A-16X1 drive models:**

NOTE The "neutral" position on a new drive unit, or one overhauled by the Manufacturer, is given by a spacer which must be removed after the unit has been adjusted.

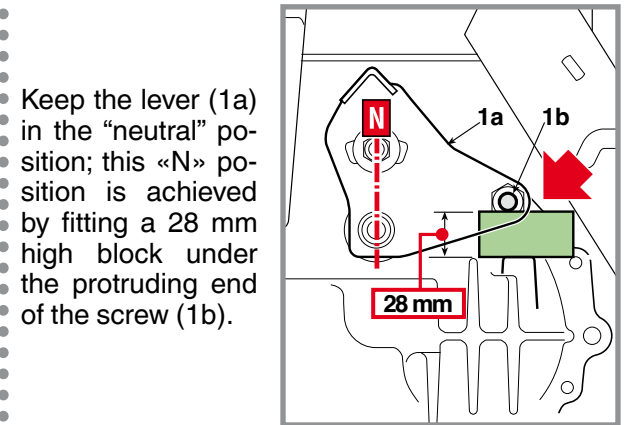

Keep the lever (1a) in the "neutral" position; this «N» position is achieved by fitting a 28 mm high block under the protruding end of the screw (1b).

Ensure the wheel cover is closed and fitted securely in place, now adjust the nuts (2) on the bar (3) until the control lever (4) is centred on the central groove (5) on the cover.

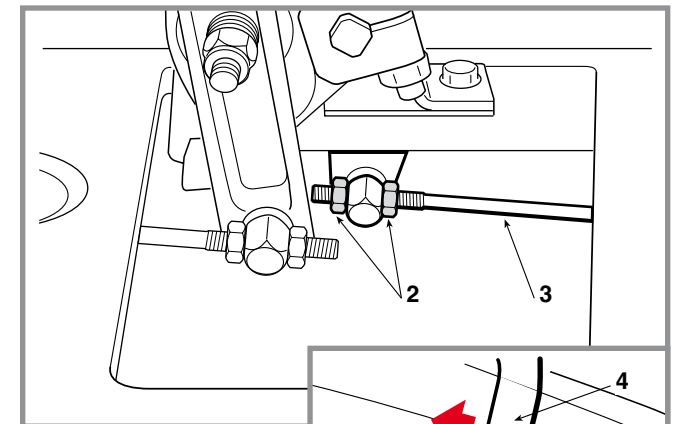

Check that the drive to the wheels engages only when the control lever (4) is moved forwards or backwards.

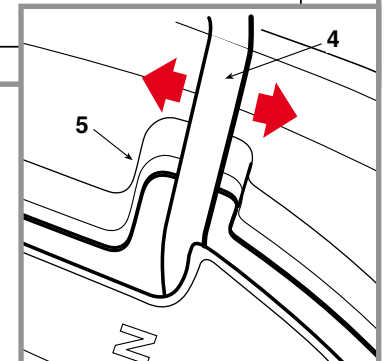

DRIVE LEVER ADJUSTMENT

CHAPTER	REVISION	FROM ...	PAGE
4.4	0	2018	2 of 3

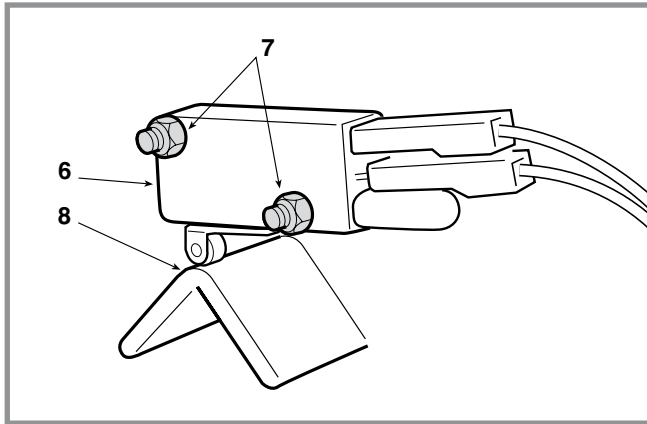

Check that the probe of the microswitch (6) is in the “pressed” position on the tip of the cam (8).

If it isn't, loosen the locknuts (7) and move the microswitch (6) sufficiently so that by moving the control lever (4) the click of the contact can be heard passing from the “pressed” position to the “released” position.

🔧 Reattach the collector channel.

B) Adjusting the release rod of the clutch device

With the brake pedal released, turn the nuts (9) until there is a free play of 0.5 mm between the shoe (10) and the release rod (11).

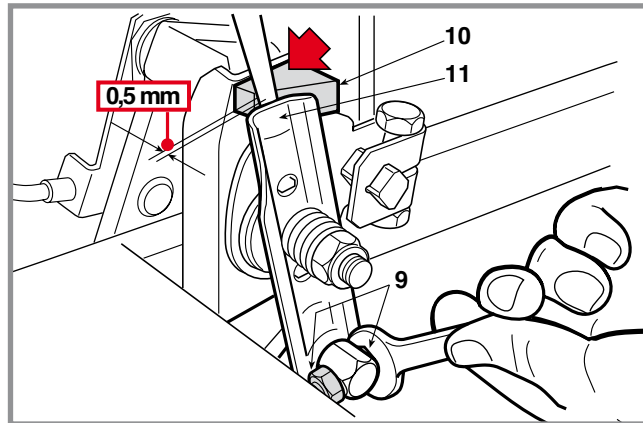

C) Adjusting the clutch device

When in motion, the lever is held in the selected position by a clutch device which is made up of a sliding sector (12) between two friction discs (13), pressed together by a spring (14).

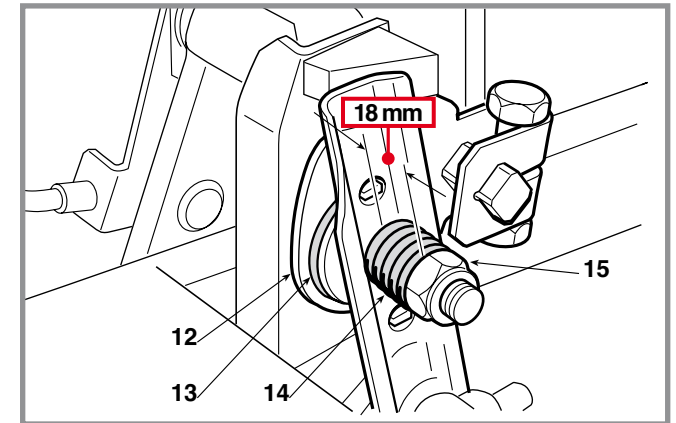

The spring tension (14) is adjusted at the nut (15) until a length of 18 mm is obtained with the pedal released.

Check that the friction discs (13) are in good condition and with no traces of oil. Otherwise replace them [see 6.10].

DRIVE LEVER ADJUSTMENT

CHAPTER	REVISION	FROM ...	PAGE
4.4	0	2018	3 of 3

D) Adjusting the lever return cable

☛ Lift the wheels cover.

With the control lever in the “neutral” position and the pedal released.

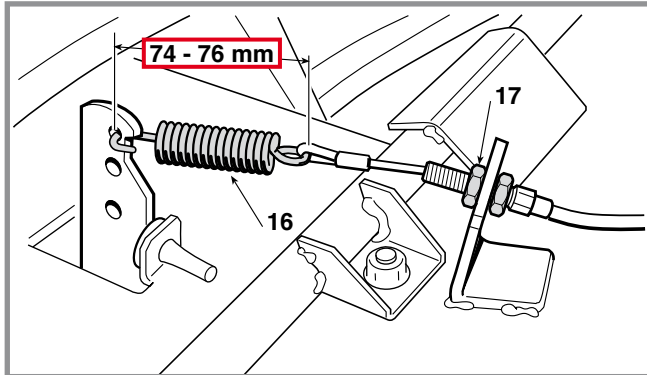

Check the length of the spring (16) and regulate the adjuster (17) until a length of 74 - 76 mm is obtained measured from the outside of the eye-rings.

When this adjustment has been made, with the parking brake engaged, there should be free play of 0.5 ÷ 1 mm between the lever (18) and the limit stop (19).

☛ Close up the wheels cover.

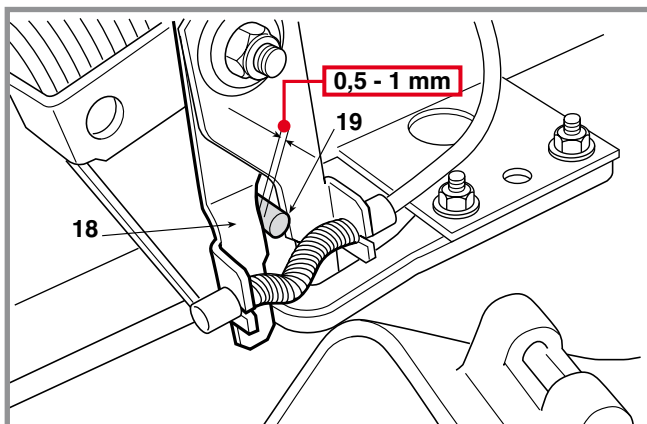

E) Adjusting the limit stop position of the levers

If the stop hook has been dismantled or replaced, the position of the terminal (20) will need to be adjusted compared to the levers (21) and (22).

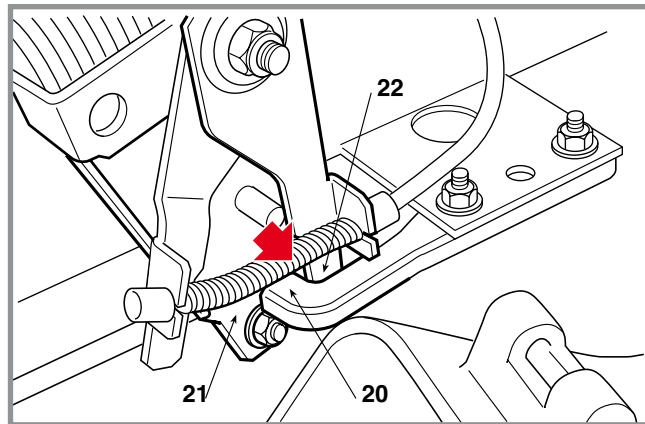

This must be a position which prevents the terminal (20) from interfering with the swinging movement of the lever (21) and blocking the lever (22) at the same time.

☛ Lift the wheels cover.

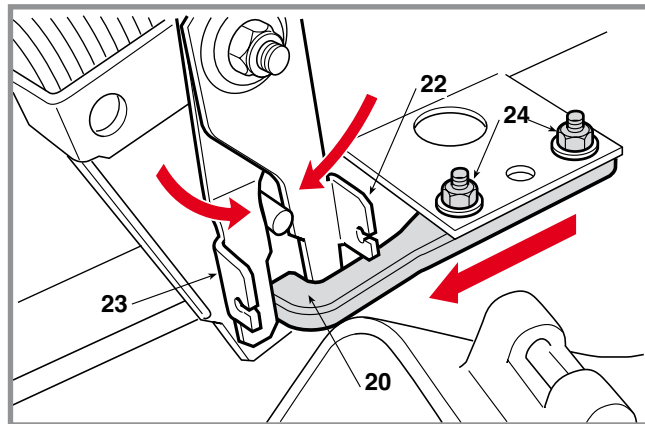

Put the control lever in “neutral” and engage the parking brake.

With both nuts (24) loosened, close the two levers (22) and (23) so that the terminal (20) is held between them, push it back as far as possible and then tighten the two screws (24).

☛ Close up the wheels cover.

ALIGNING THE CUTTING DECK

CHAPTER	REVISION	FROM ...	PAGE
4.5	0	2018	1 of 2

General informations

The cutting deck is lowered by a lever and is guided by a connecting rod at the front and one at the back right. A third connecting rod at the front left is connected to the deck by an adjuster system.

In order to get a good cut it is essential that the cutting deck is parallel with the ground crosswise, and slightly lower at the front.

Two adjustments can be made on the jointed system of the cutting deck:

- a) a combined adjustment to the parallel and the minimum height front and back
- b) an adjustment to just the parallel across the cutting deck

Related topics

[2.2] Tools

Tightening torques

Front (Tyres 11 x 4-4) 1,5 Bar

Rear (Tyres 16 x 6-6) 1,0 Bar

Map of functional units

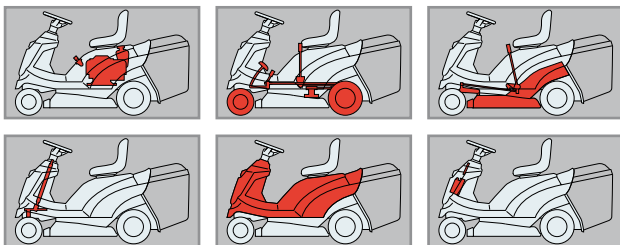

Check the tyre pressures. If one or more tyres have been replaced or you find differences in diameter, do **not attempt to compensate these differences by giving different tyre pressures**, but make the adjustments as in points «A» and «B».

Remove the left and right side guards.

A) Combined adjustment to the parallel and the minimum front and rear height

Put the machine onto a flat and stable surface (such as a work bench) and put blocks beneath the cutting deck:

- at the front 26 mm (1)
- at the rear 32 mm (2)

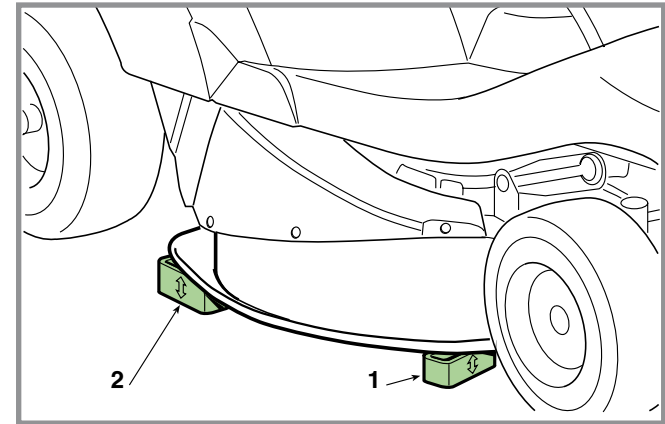

Put the cutting height adjustment lever into the notch at position «1».

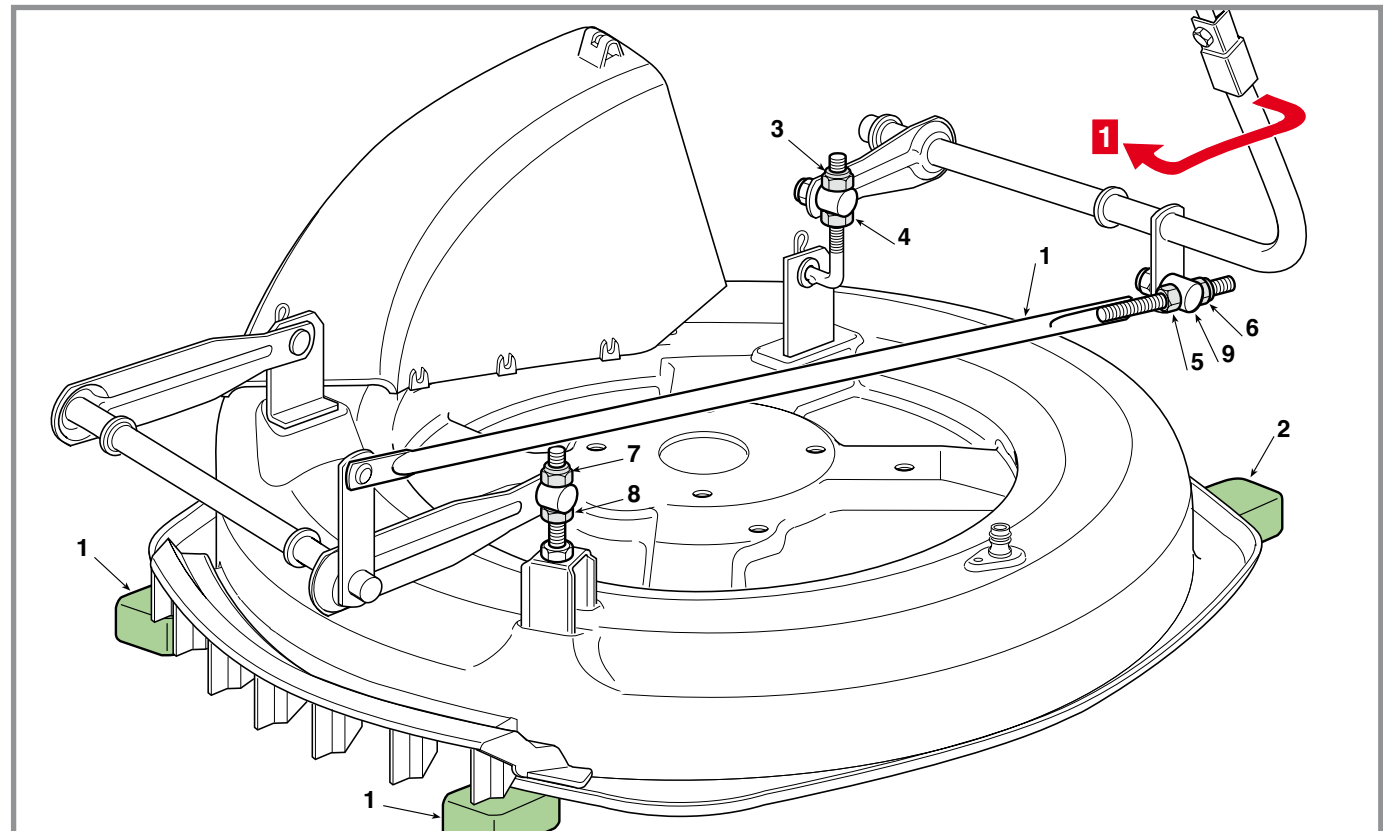

Loosen the nuts (3 – 5 – 7) and the locknuts (4 – 6 – 8) so that the deck rests firmly on the blocks.

Screw down the nut (3) until the front part of the cutting deck starts to rise, then tighten the relevant locknut (4) in order to create a fixed reference point for the following stages.

Turn the nut (5) so that it presses on the pin (9) and causes the rod (10) to move forward until all free movement is eliminated and the front right of the deck begins to rise.

Having checked that the rod has no possibility of longitudinal movement, tighten the locknut (6).

Screw down the nut (7) of the transverse adjuster until the front left begins to rise, and then tighten the locknut (8).

NOTE Remember to tighten all the nuts and locknuts once these adjustments have been made, leaving the necessary free rotation movement to the pins.

! WARNING! Reassemble the right and left side guards.

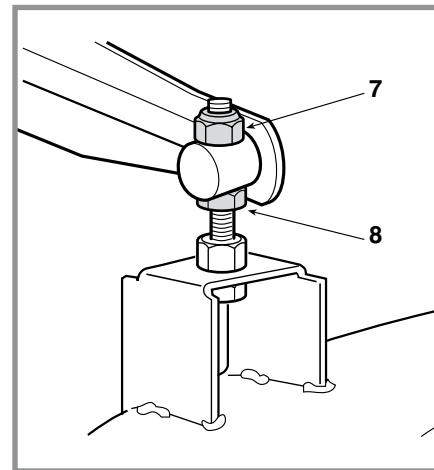
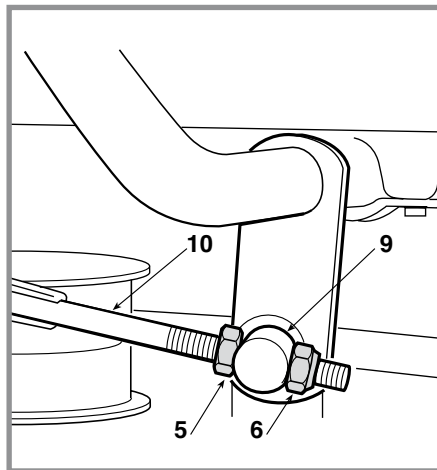
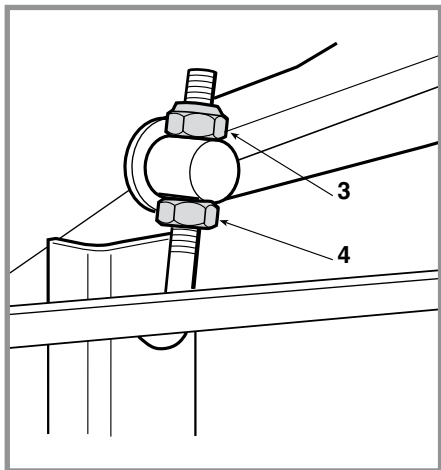
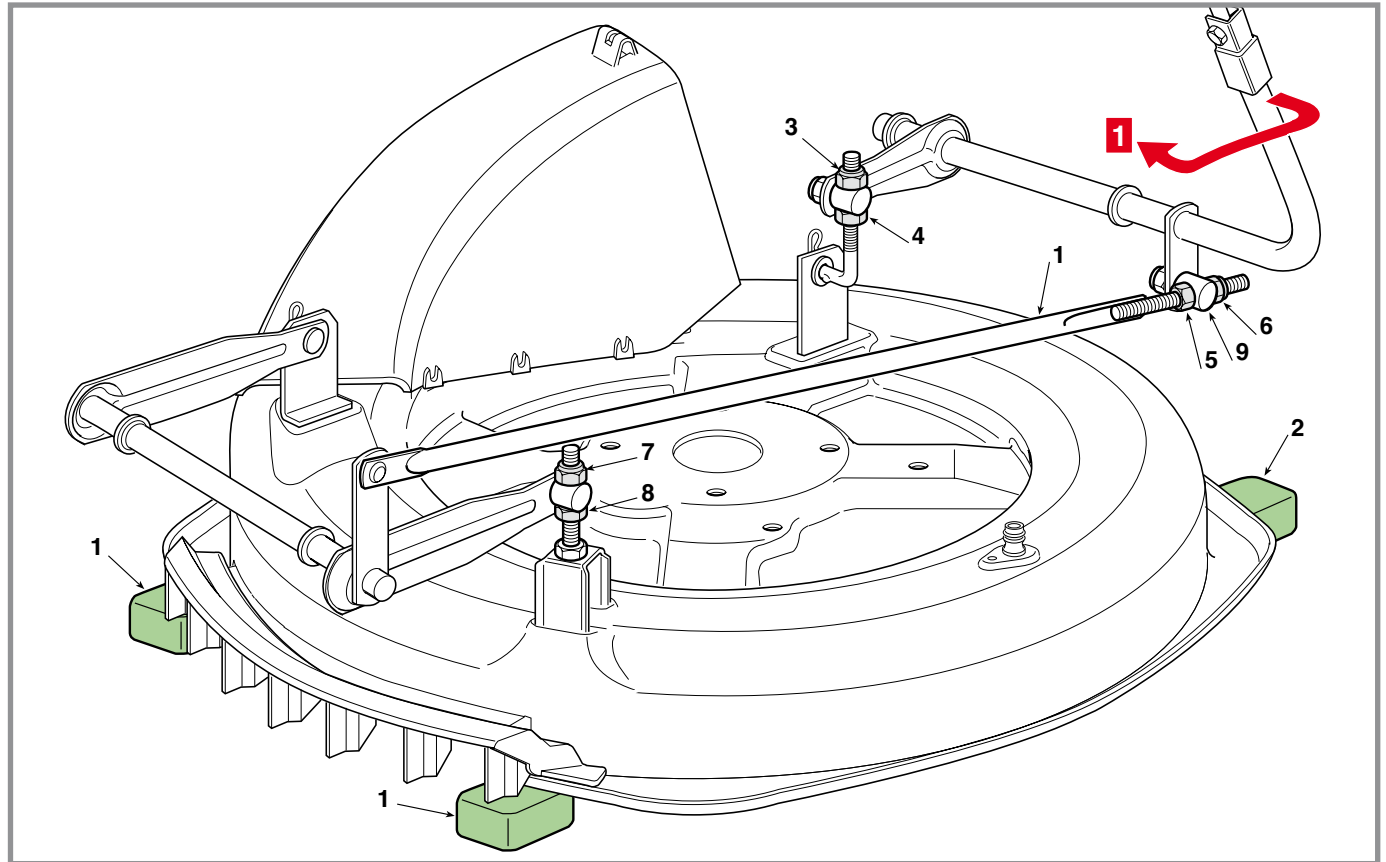

B) Adjusting the parallel across the cutting deck

Any difference in height from the ground between the left and right sides of the deck can be compensated by turning the nut (7) and the locknut (8) at the front left coupling point.

NOTE Remember to tighten all the nuts and locknuts once these adjustments have been made, leaving the necessary free rotation movement to the pins.

! WARNING! Reassemble the right and left side guards.



ADJUSTING THE STEERING PLAY

CHAPTER	REVISION	FROM ...	PAGE
4.6	0	2018	1 of 2

General informations:

Steering play must never be excessive in order not to effect driving precision.

Related topics

-  **5.1** Removal of the steering column protection cover
-  **5.2** Removal of the footboard
-  **6.3** Replacement of steering components

Tightening torques

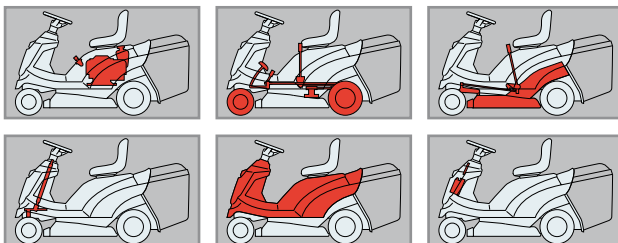

5 Ring gear fixing screw 25 ÷ 30 Nm

Map of functional units



Check that the movement is not caused by loose linkage nuts and tighten all the nuts of the tie-rods and ball joints.

If the movement is in the pinion to ring gear coupling, the height of the ring gear will need to be adjusted by inserting spacers inside the hub.

-  Remove the front and rear protection cover of the steering column.
-  Remove the footboard.

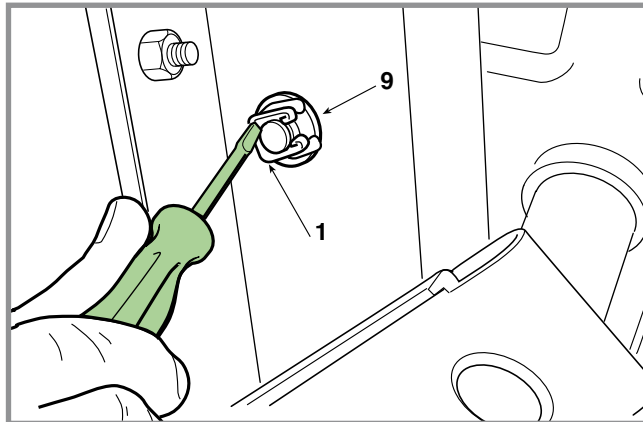

Unhook the spring (1) and lift the steering column (2) far enough to be able to take out the pin (3) and the pinion (4).

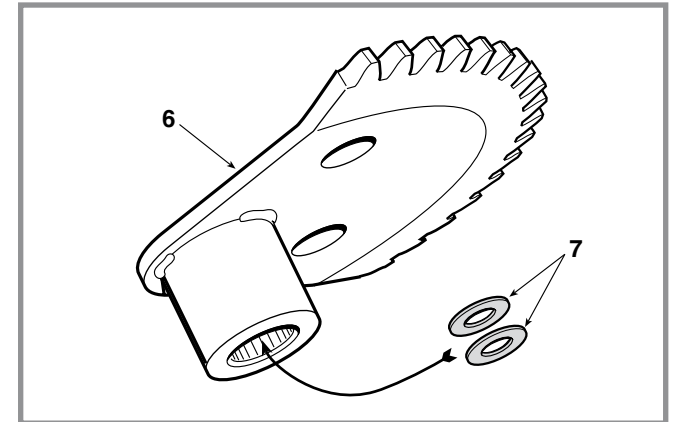
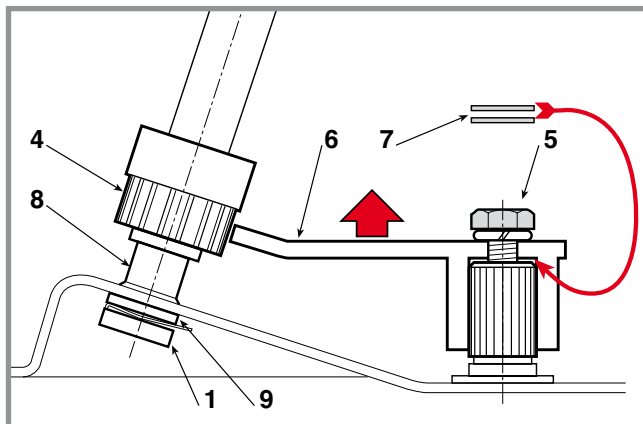

Undo the screw (5) and take out the ring gear (6). Put one or two 11 x 17 x 0.5 mm spacers (7) (according to requirements) inside the hub so that the ring gear is raised higher than the pinion.

Line up the front wheels and refit the ring gear (6) with the arrow pointing forwards, then fully tighten the screw (5).

 Turn the steering column so that the hole of the pin (3) is at right angles to the longitudinal axis of the machine, and then fit the pinion (4) so that the pin is fully inserted in its seat.

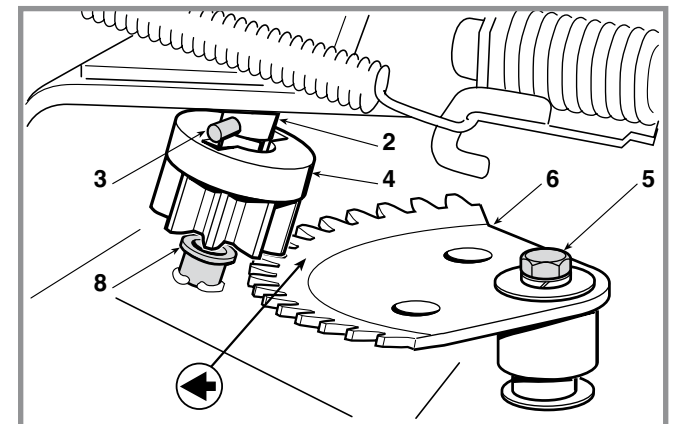

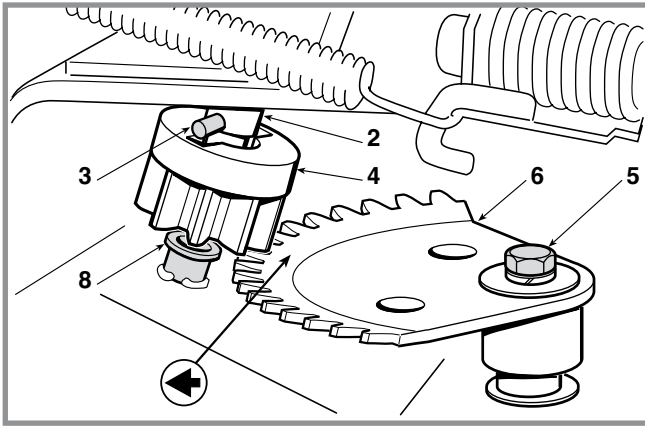

Push the end of the steering column (2) right down in the hole of the bush (8), check that the teeth of the ring gear in the new position are correctly meshed with those of the pinion and finally, refit the washer (9) and the spring (1).

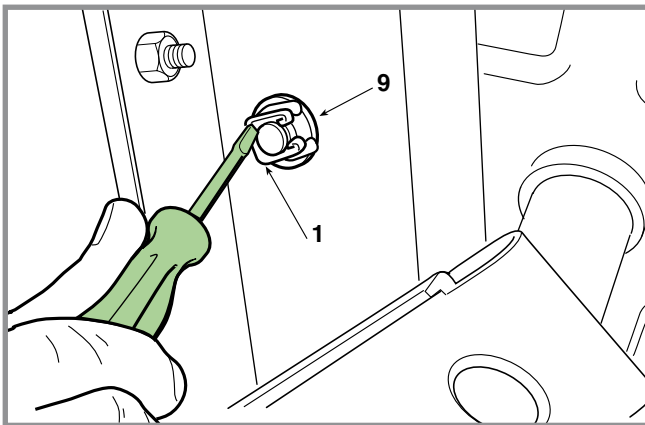

If the movement is still there after having removed all the spacers, check it and if necessary, replace the ring gear/pinion unit, or look for other possible causes.

When all parts have been fitted, ...

- ☛ Fit the footboard.
- ☛ Fit the front and rear protection covers of the steering column.

General informations

The correct steering geometry is given by the distances between centres of the two tie-rods connecting the wheels. Any faults caused by knocks or accidents result in reduced driving precision and increased wear on the tyres.

These can be overcome as follows:

- uneven or excessive wear on the front tyres = toe-in adjustment,
- the machine does not maintain a straight line when the steering wheel is straight = adjustment of tie-rods.

Related topics

Tightening torques

3 Locknuts for articulated joints 25 ÷ 30 Nm

5 Fastening nuts for articulated joints. 45 ÷ 50 Nm

Map of functional units

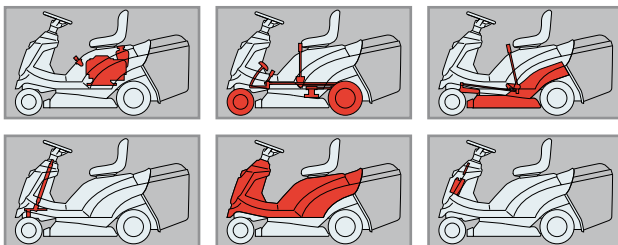

NOTE Before any other action, check that the ball joint connections have not become loose.

A) Toe-in check

The exact toe-in is obtained when there is a distance of 429 - 431 mm measured between the two centres of the stub axle joints (1) which is obtained when the distance between the joints of the two tie-rods (1 - 2) is 200.5 - 201.5 mm.

If the amount is different to this, check if the error is due to one or both of the tie-rods. Dismantle the part concerned, loosen the locknut (3) and screw the joint up or down on the rod (4) until achieving the exact amount.

IMPORTANT The two tie-rods must always be adjusted to the same length.

On fitting, fully tighten the locknuts (3) and the nuts (5) fastening the joints.

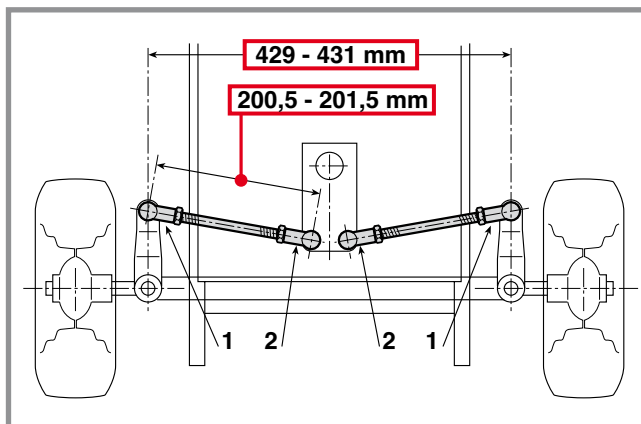

B) Adjusting the steering wheel position

Firstly check the toe-in (point "A") and align the front wheels.

If the steering wheel is not straight, check that both tie-rods have the same distance between the joints (1 - 2) (200.5 - 201.5 mm).

Having identified the part that has a different length, adjust as indicated in point "A".

On fitting, fully tighten the locknuts (3) and the nuts (5) fastening the joints.

When the adjustment has been made, check the toe-in as described at point "A".

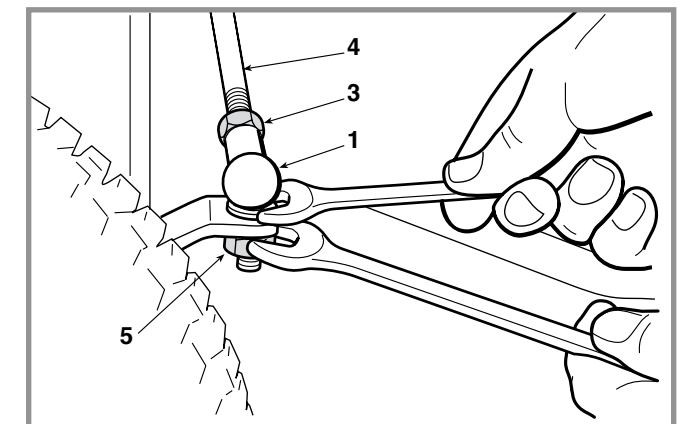

CHECKING BLADE ALIGNMENT

CHAPTER	REVISION	FROM ...	PAGE
4.8	0	2018	1 of 1

General informations

Excessive vibration when cutting and an uneven cut can be due to misalignment of the blade owing to deformation of the flange or the shaft as a result of accidental knocks.

Related topics



 **2.4** Placing the machine on its side

 **5.8** Removal of the cutting deck

 **6.6** Replacement of the support and shaft of the blade

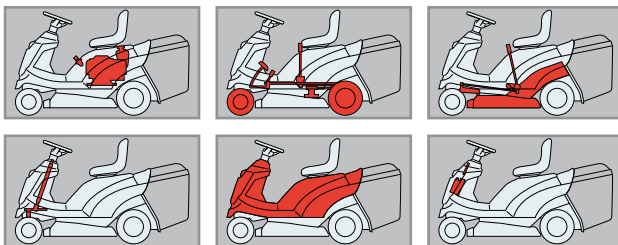
Map of functional units



-  Place the machine on its side
or:
-  Remove the cutting deck.

 **WARNING!** Always wear strong gloves when handling the blade.

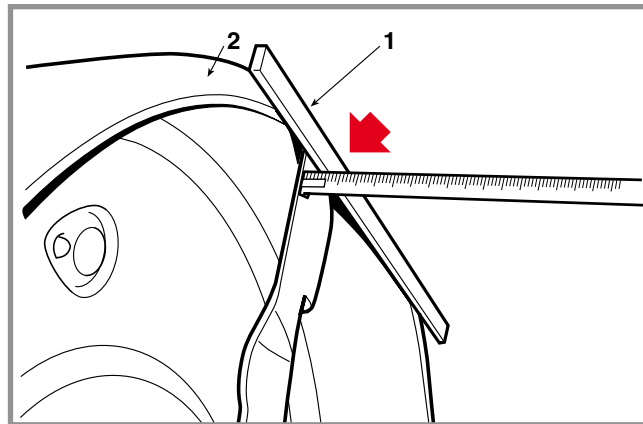

Disengage the blade, place a straight metal rod (1) on a point around the edge of the deck (2), turn the blade by hand and check the distance between the rod and the two ends "A" and "B". The distance should be the same, and any difference should not exceed 2 - 3 mm.

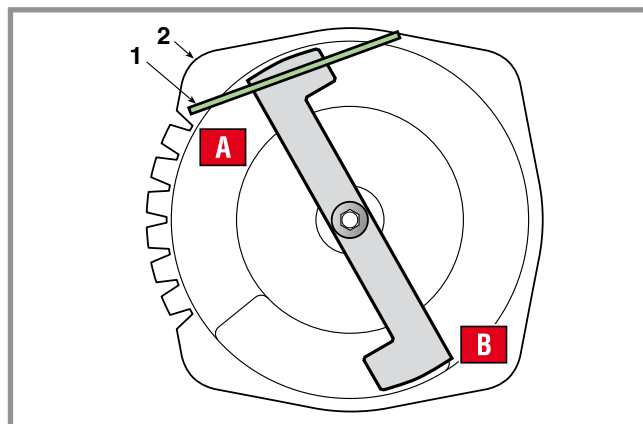

If higher amounts are found, check that the blade is not distorted. If this is not the case, check the support or the shaft for the blade, replacing if necessary, and check the condition of the point where the flange rests on the cutting deck.

 **IMPORTANT** - Always replace damaged blades and do not attempt to repair or straighten them. Always use manufacturer's genuine spare parts!

REMOVING, SHARPENING AND BALANCING THE BLADE

General informations

A badly sharpened blade causes grass to become yellow and reduces grass collection capability. If not balanced, excessive vibration can be caused during use. Fins broken, bent or damaged reduce the grass expulsion force and can cause damage and injuries.

Related topics

[🔧 2.4] Placing the machine on its side

[🔧 5.8] Removal of the cutting deck

Tightening torques

1 Screw blade 45 ÷ 50 Nm

Map of functional units

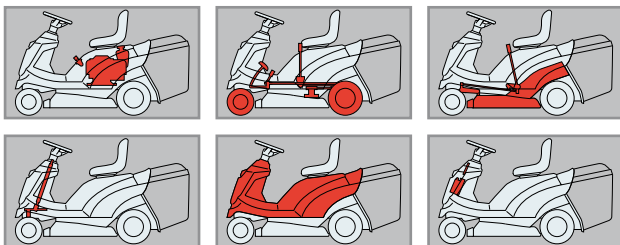

- ☛ Place the machine on its side
or:
- ☛ Remove the cutting deck.

⚠ WARNING! Always wear protective gloves when handling the blade and protect eyes when sharpening.

A) Removing and reassembling

For removing a blade it must be firmly held and the central screw (1) undone.

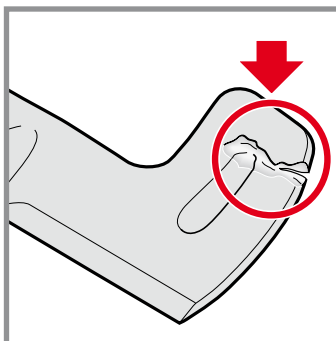
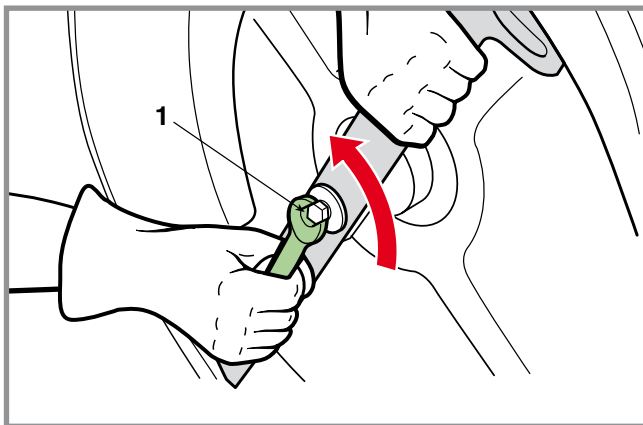

⚠ Always check that the fins are intact with cracks or breaks. Always replace damaged blades.

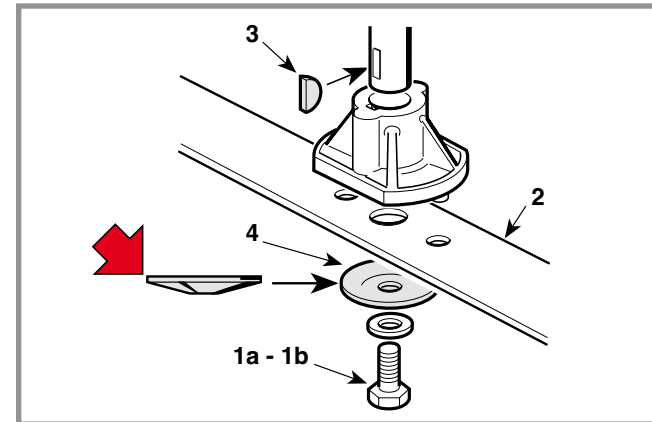

⚠ On assembly, be careful to:

- correctly position the keys (3) on the shafts;
- correctly locate the blade, with the fins facing towards the inside of the cutting deck;
- fit the flexible disc (4) so that the concave part is pressing against the knife;
- tighten the screw (1) with a torque wrench set to 45-50 Nm..

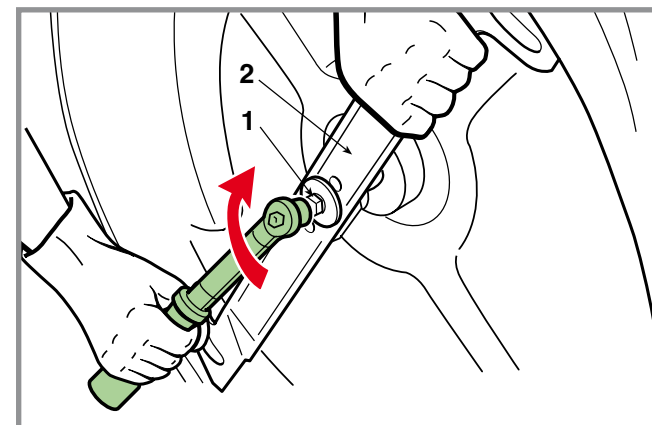

B) Sharpening and balancing

Always sharpen both cutting edges of the blade (2) using a medium grade grinder. Sharpening must only be done from the rounded side, removing as little material as possible.

The blade is to be replaced when the cutting edge has worn down to 10 mm.

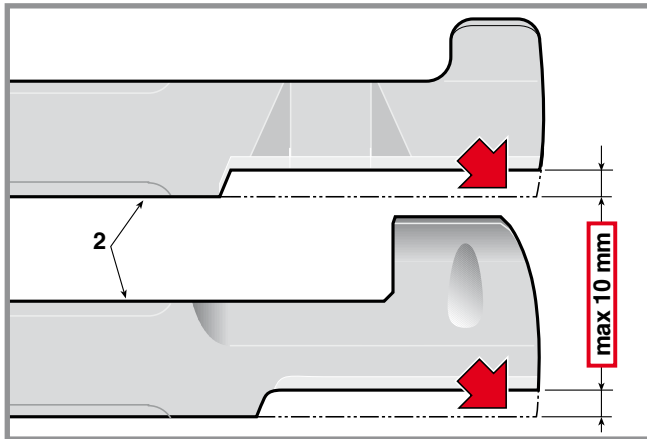

Using the appropriate equipment, check the balance to make sure that there is a maximum difference of 2 grams between one side and the other.

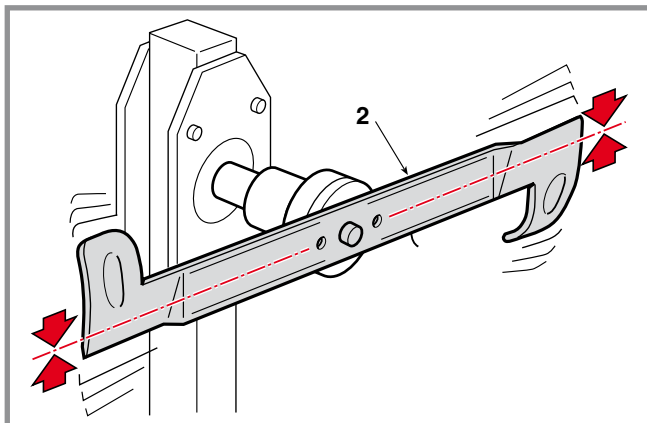

ADJUSTMENT OF THE COLLECTOR CHANNEL GUIDE

CHAPTER	REVISION	FROM ...	PAGE
4.10	0	2018	1 of 1

General informations

This adjustment is to be made after any work on the collector channel guide and if the rear plate has been dismantled.

The importance of this adjustment is in avoiding that incorrectly inserting the channel opening in the hole in the plate prevents the wheels cover from closing properly which could let grass cuttings get into the engine housing causing damage.

Related topics

[🔧 2.5] Opening the wheel cover

[🔧 5.5] Removal of the collector channel

Map of functional units

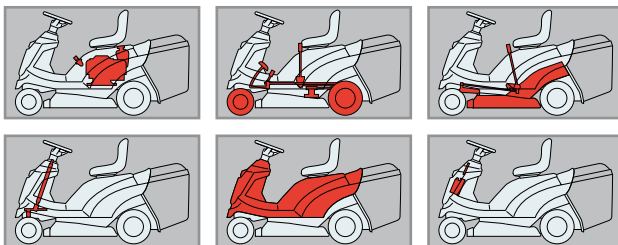

- 🔧 Fit the collector channel.
- 🔧 Turn back the wheels cover

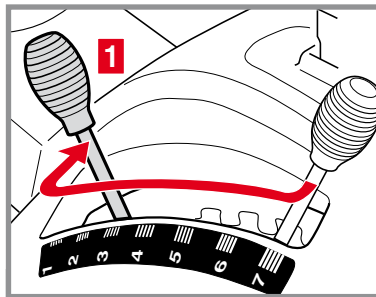

Take the cutting deck to position «1». In this condition, the channel (1) should be properly sitting in the guide (2).

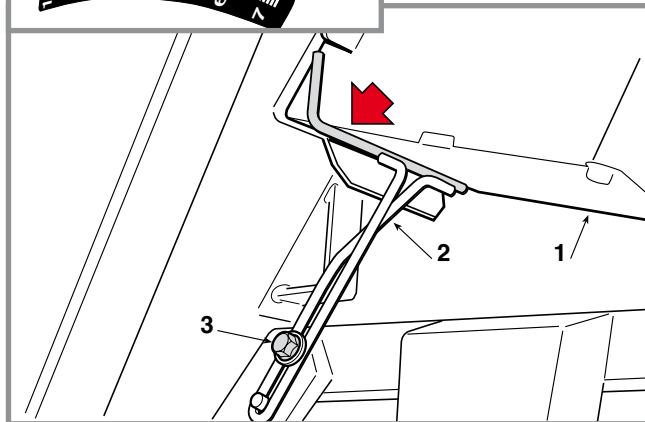

If the guide is lower or tends to raise the channel too much, loosen the screw (3) and make the guide slide until it is repositioned correctly.

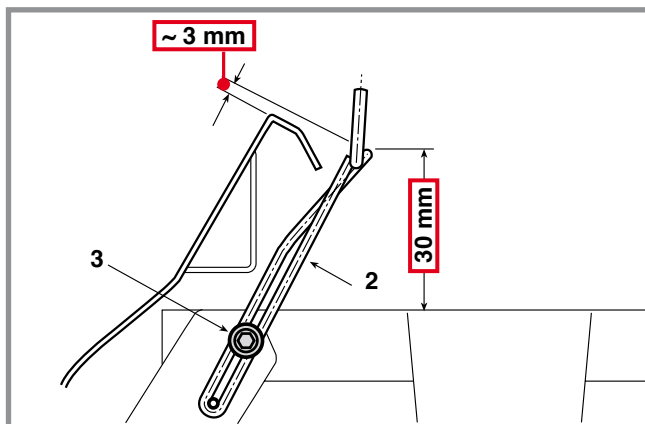

IMPORTANT Always check that, when the wheels cover is closed according to the regular procedure, the channel always inserts in the hole of the plate regularly and automatically, and with no need to help it in manually.

General informations:

If it seems that the forward drive is not working properly after a long period of use or after replacing the belt, this may be caused by a change in the length of the belt.

- A loose belt reduces output from the transmission and limits forward movement power;
- a belt which is too tight increases noise and results in jerky movements or tipping up when engaging the drive.

In these cases the stretcher will need to be adjusted.

Related topics:

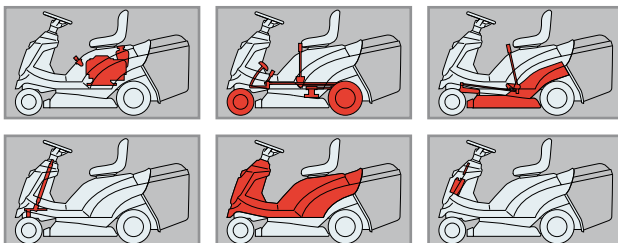
Map of functional units**► mechanical drive models**

The stretcher can be reached through the hatch at the base of the seat.

Adjust the tension of the spring (1) by turning the nuts (2) until you obtain a length of 86 mm measured from the outer ends of the spring, with the drive controls released.

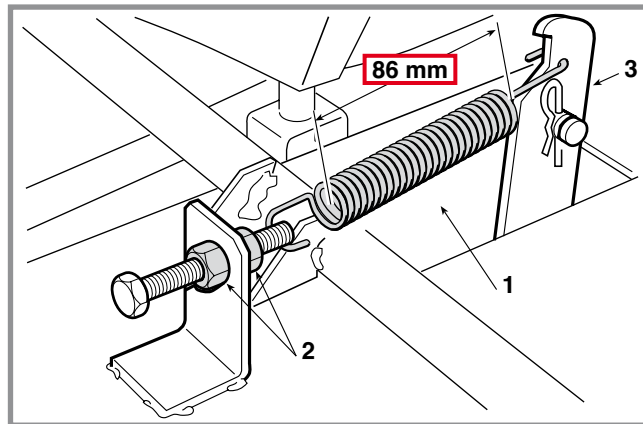

In this condition, the control lever (3) should be completely vertical.

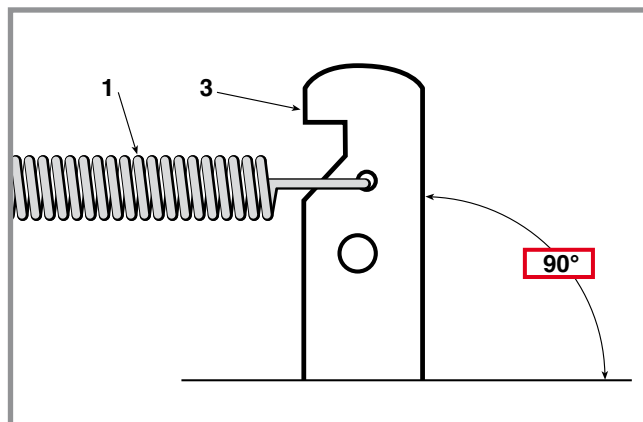

When the adjustment is done, tighten the nuts (2).

REMOVAL OF THE STEERING COLUMN PROTECTION COVER

General informations

The battery can be removed if the front part of the steering column guard is disassembled.

On removing the rear part of the steering column guard you have access to:

- blade engagement micro-switch;
- electronic card;
- engine start solenoid valve.

Related topics

Map of functional units

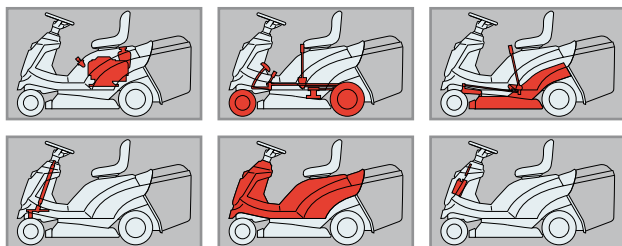

A) Removal of rear guard

Remove the knob (1) of the blade engagement lever.

Unscrew the 4 side screws (2) and disassemble the guard (3).

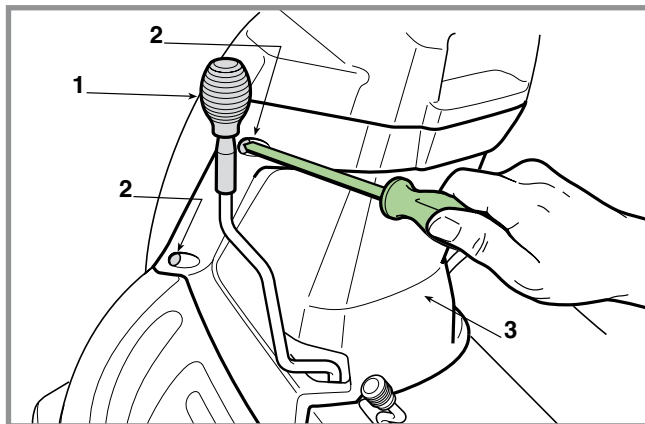

B) Removal of front guard

Remove the rear guard as shown in point «A».

Using a screwdriver, unhook the two central hooks and the two right and left hooks (11) holding the steering wheel cover (12).

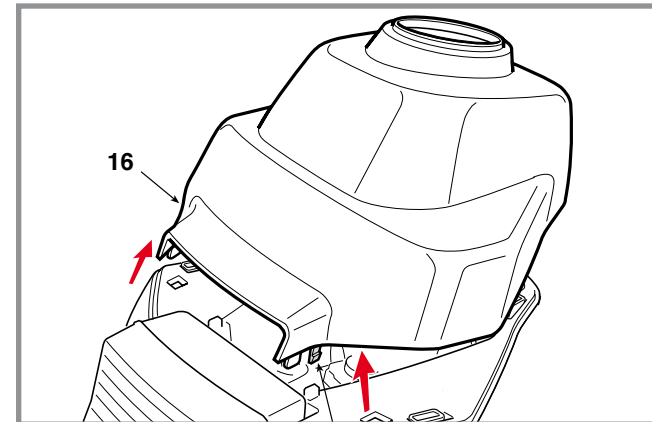
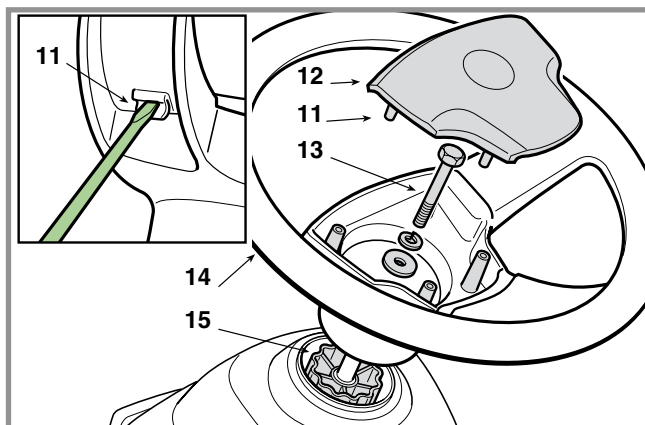

Unscrew the central screw (13), dismantle the steering wheel (14) and extract the steering column extension (15).

Dismantle the upper part of the dashboard (16), unhooking the four hooks (17).

Remove the front hatch (18).

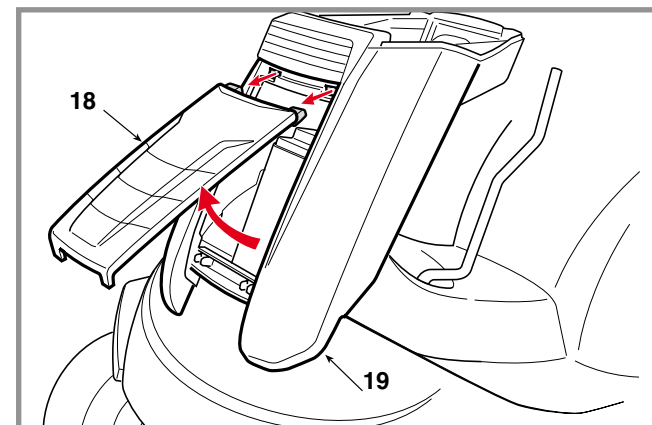

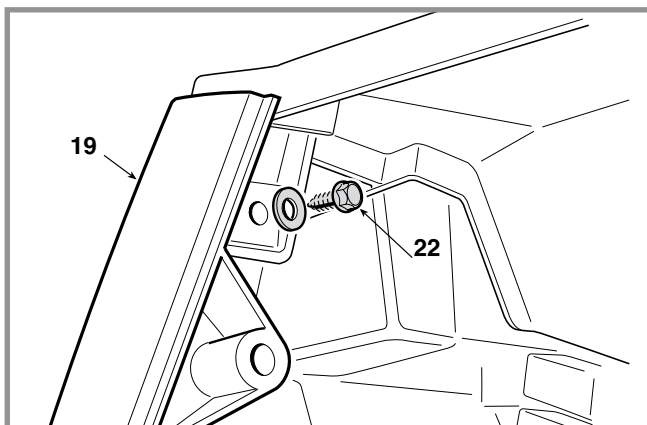
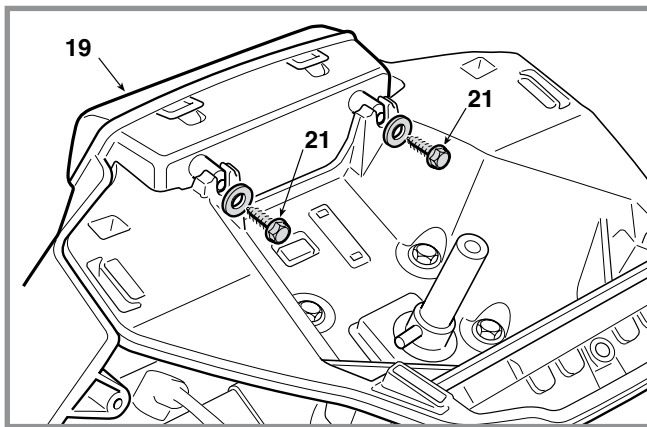
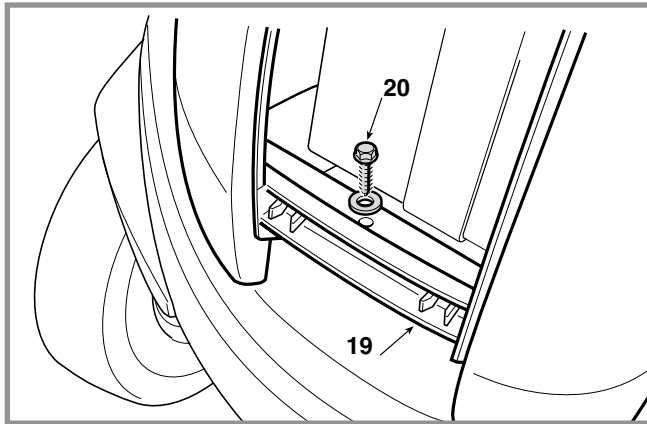
**REMOVAL OF THE STEERING COLUMN
PROTECTION COVER**

The front guard (19) is fixed by:

- a lower screw (20) inside the front space;
- two upper screws (21);
- two screws (22) under the dashboard base.

When mounting, reverse the operations described above, making sure you restore connections to electric connectors removed during disassembly.

REMOVAL OF THE FOOTBOARD

General informations:

Removing the footboard gives access to the pinion and the ring gear of the steering.

Related topics

 **5.1** Removal of the steering column protection cover

Tightening torques

7-8 Self-threading screws for the footboard 6,5 Nm

Map of functional units

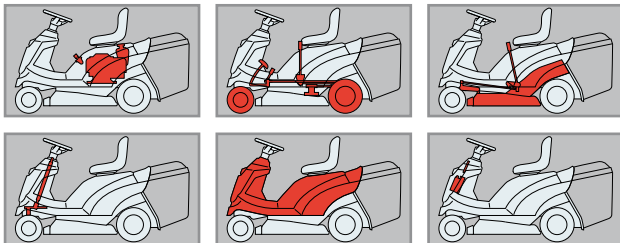

 Remove the steering column protection cover.

Dismantle the pedal (1) by unscrewing the two nuts (2).

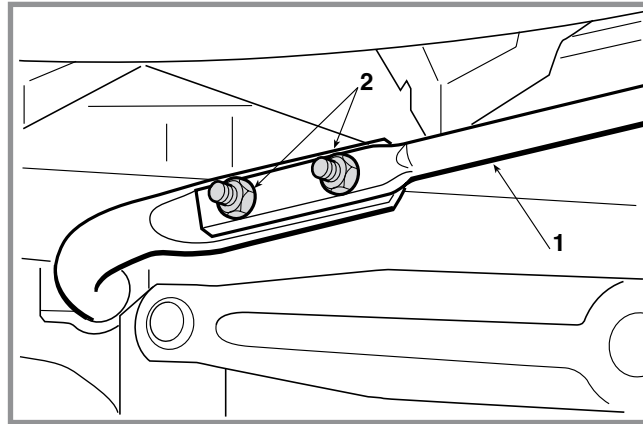

Unscrew the knob (3) of the parking brake and remove the reverse consent pedal (3a) held in place by the screw (3b).

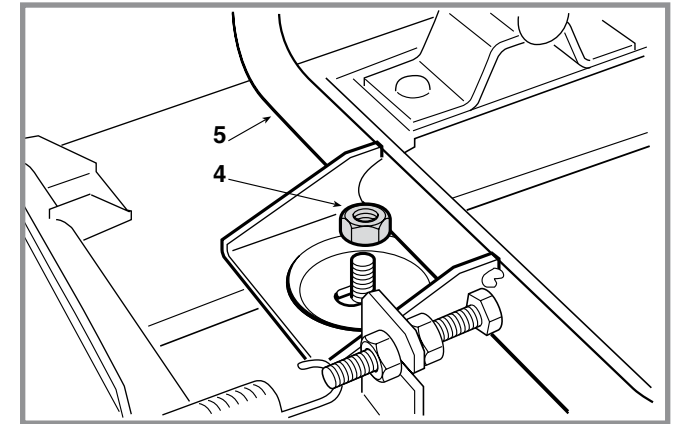
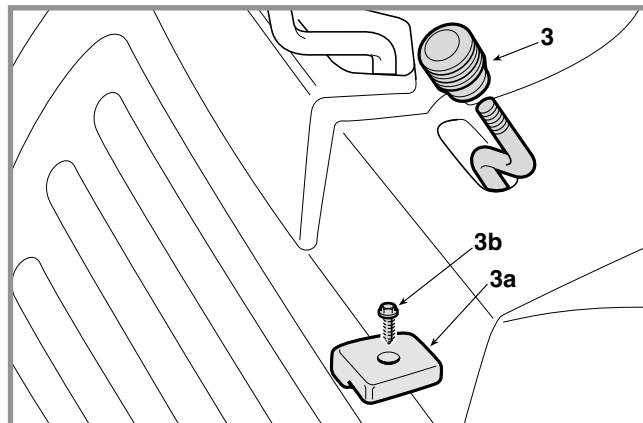

Unscrew the nut (4) to slightly lift the wheels cover (5).

The footboard (6) is held to the frame by four internal screws (7) and four longer external screws (8) with washers (9) for resting on the tubular support element.

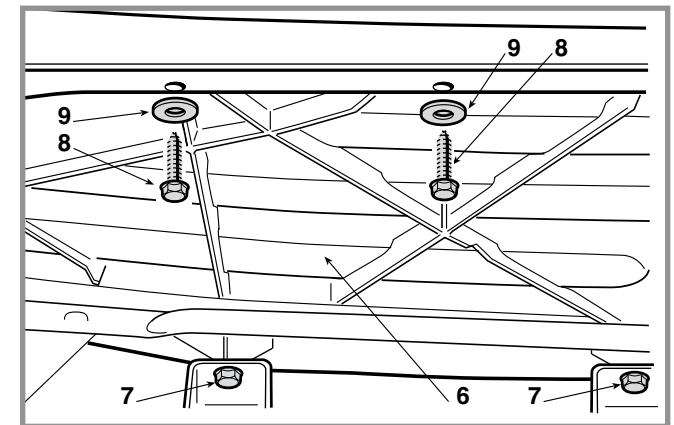

On refitting, reverse the order of the previous steps, remembering to put the washers (9) under the screws (7).

 Refit the protection covers of the steering column.

REMOVAL OF THE WHEEL COVER

CHAPTER	REVISION	FROM ...	PAGE
5.3	0	2018	1 of 2

General informations

Removing the wheels cover may be necessary for:

- improving access around the engine,
- removing the rear plate.

Related topics

[🔧 2.5] Opening the wheel cover

[🔧 6.7] Replacement of the accelerator

[🔧 6.11] Replacement of the seat's safety cable

Tightening torques

9-11-12 Self-threading screws for wheels cover 6,5 Nm

10 M6 screws for wheels cover 8 ÷ 10 Nm

Map of functional units

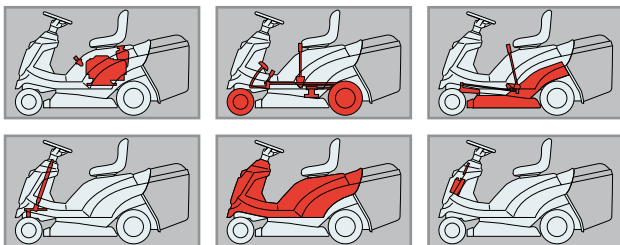

- ▶ **with STIGA and Honda GXV390 engines:**
- 🔧 Release the seat safety cable from the wheel cover side.

🔧 Remove the accelerator from the wheel cover side.

Unscrew the lever knob (2).

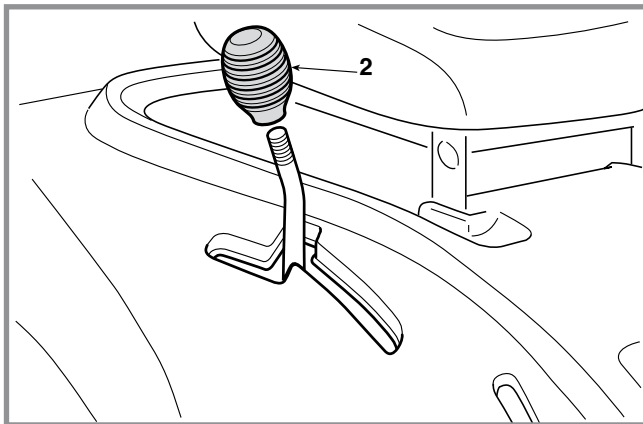

Remove the split pin (3) and remove the pin (4) to disassemble the seat.

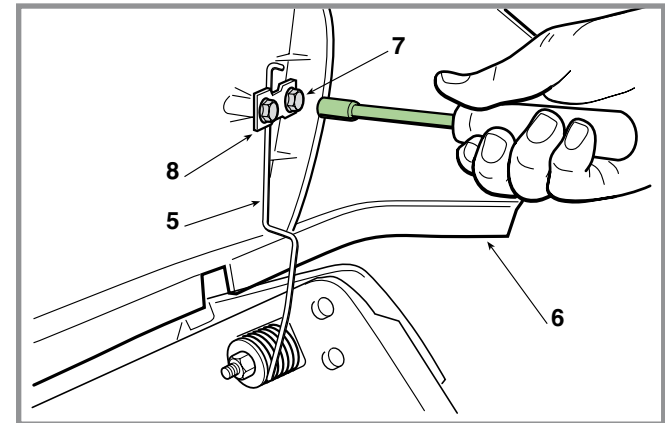
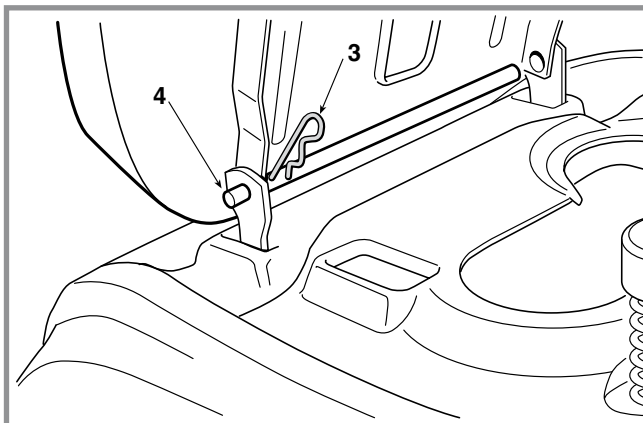

Release the spring (5) of the fixed cover of the grass-catcher (6), by undoing the screws (7) which hold on the small plate (8).

Undo the two self-threading screws (9) and loosen the two screws (10) with nuts that hold the cover onto the rear plate.

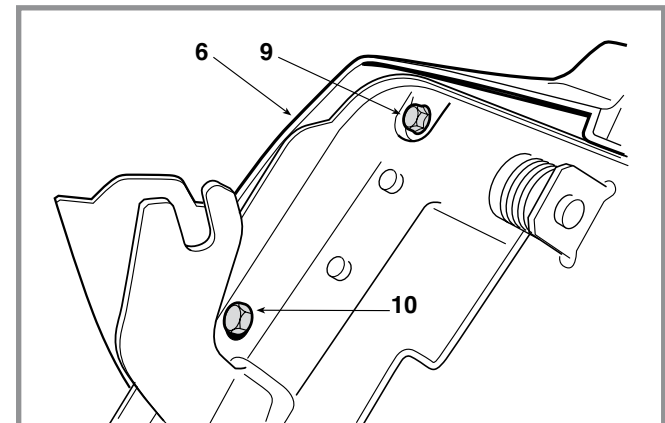

REMOVAL OF THE WHEEL COVER

☞ Lift the wheels cover.

Undo the six screws which attach the tubular element. Two of them are short (11) and four are longer (12) and they can be reached from below.

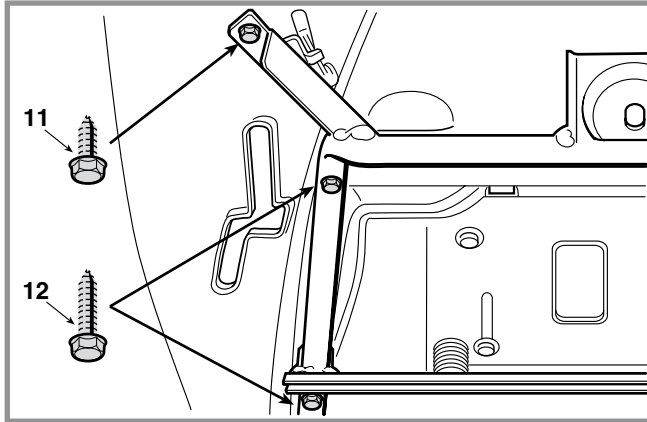

! WARNING! *When reassembling, do not forget to reattach the connector of the seat microswitch and to make sure it works.*

☞ Close up the wheels cover.

REMOVAL OF THE REAR PLATE

General informations:

The rear plate does not need to be removed for access to other parts for work. The following procedure is only for replacing with a new one.

Related topics

[\[4.10\]](#) Adjustment of the collector channel guide

[\[5.3\]](#) Removal of wheels covers

Tightening torques

6 Hinge screws, rear plate 8 ÷ 10 Nm

7 Screws for attaching rear plate 25 ÷ 30 Nm

Map of functional units

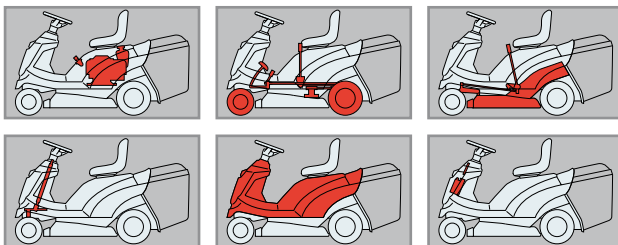

Remove the wheels cover.

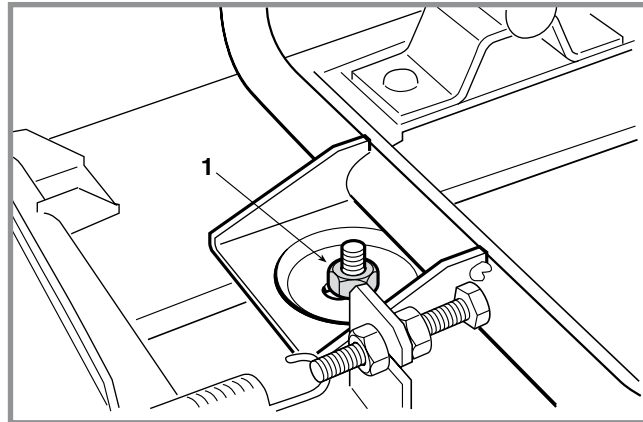

Close up the frame of the cover, tightening the fixing nut (1).

Detach the electrical connections from the “grass-catcher attached” microswitch (2).

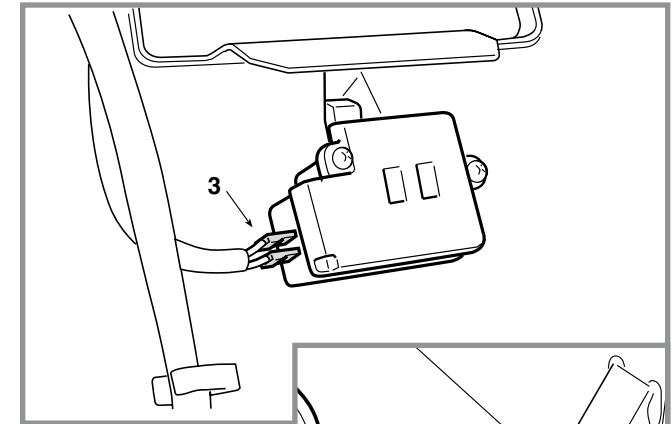
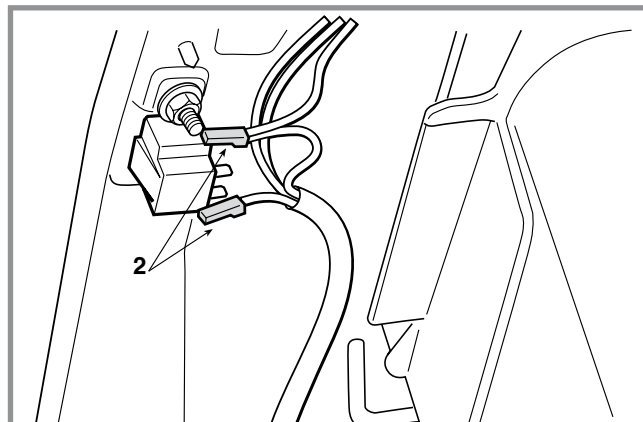

The “grass-catcher full” microswitch (3) and release the stop cable (4).

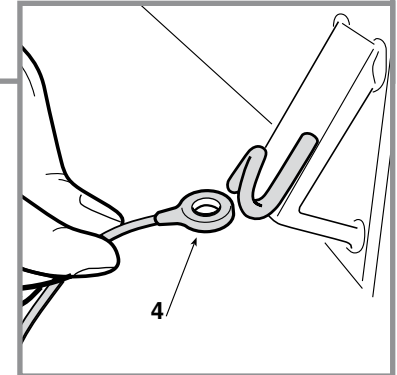

The plate is hinged at the base of the machine’s frame by two small plates (5), each of which is fixed by four screws (6), and is attached to the frame of the wheels cover by four screws (7).

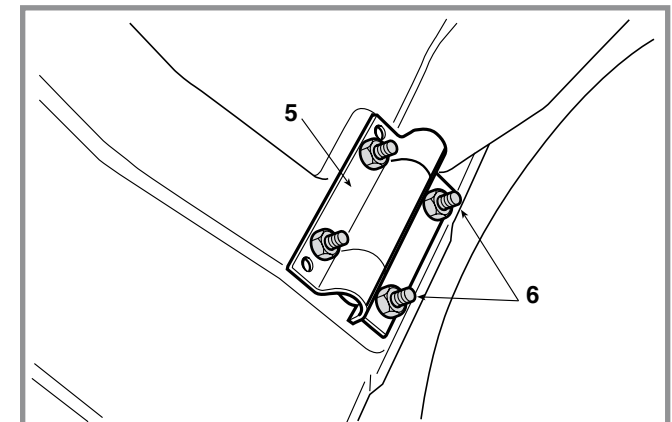

REMOVAL OF THE REAR PLATE

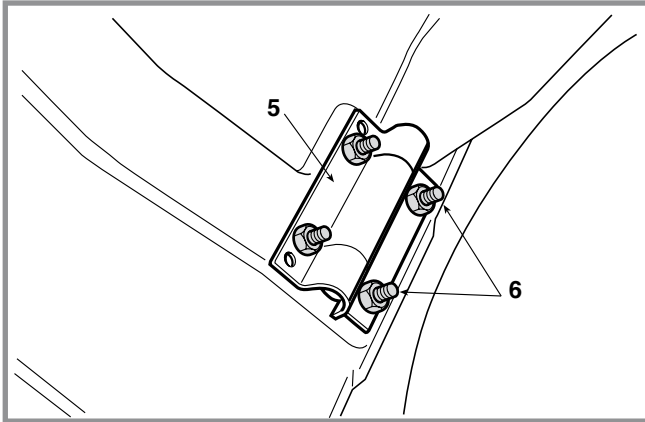

First of all, undo the four upper screws (7) and then dismantle the two lower plates (5), ensuring that the wheels cover frame has the necessary stability since, by removing the plate, it is without support at the back.

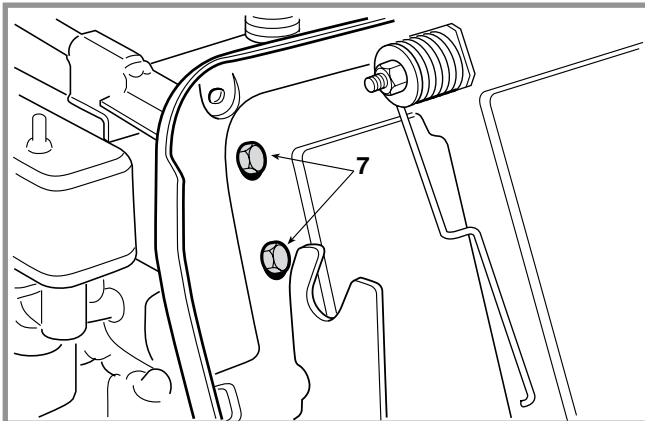

To reassemble the plate, start from the two hinges below and then attach the upper part of the frame of the wheels cover.



IMPORTANT *Reattach all the electrical connections and make sure that the microswitches are working.*

- ☛ Reassemble the wheels cover.
- ☛ Check that the channel fits in the opening.

General informations

Removing the conveyor is necessary for:

- draining oil from the engine,
- accessing the right-hand side of the engine.

Related topics

[\[🔧 2.5\]](#) Opening the wheel cover

Map of functional units

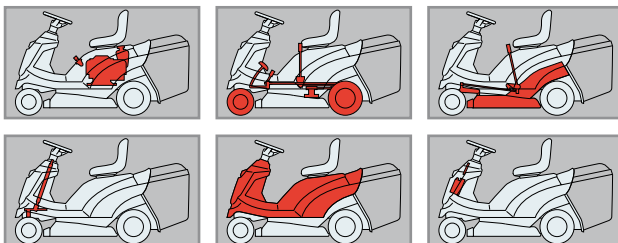

🔧 Turn back the wheels cover.

The channel (1) can be removed by releasing one of the two split pins (2) and taking out the pin (3).

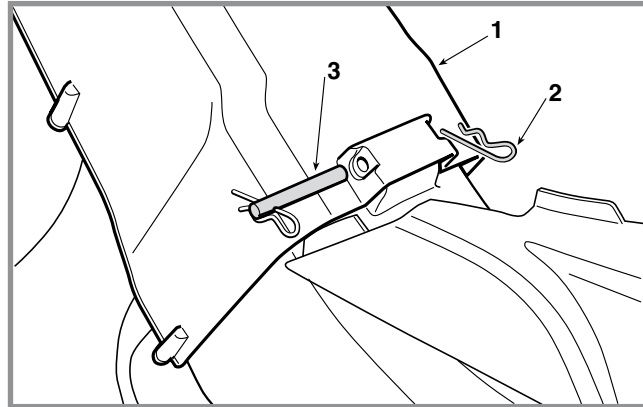

REMOVAL OF THE ENGINE

General informations

Since there are different types of drive, the stages described here refer to those shared or similar in all types of engine.

Related topics

[🔧 2.5] Opening the wheel cover

[🔧 6.7] Replacement of the accelerator

Tightening torques

1 Screw for engine pulley	45 ÷ 50 Nm
- Screws for engine fastening	25 ÷ 30 Nm

Map of functional units

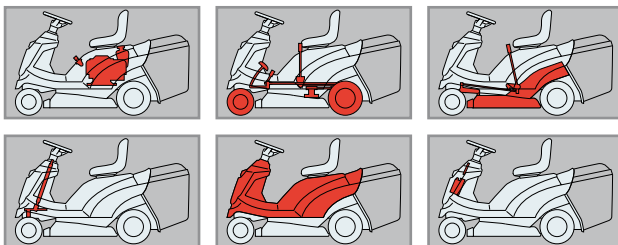

🔧 Turn back the wheels cover.

Disengage the blade to loosen the belt. The transmission belt should also be loosened. To do this:

➤ **mechanical drive models**

Engage the parking brake.

➤ **hydrostatic drive models**

Release the spring (1) of the stretcher.

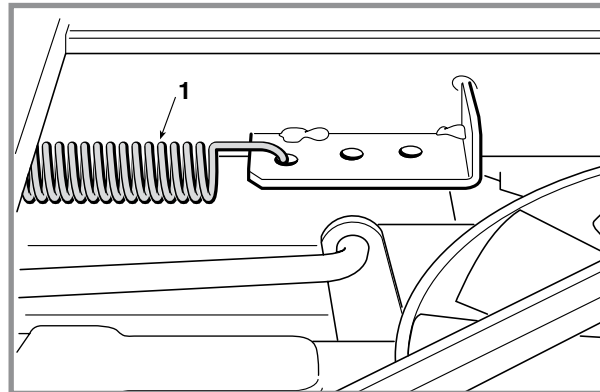

Undo the central screw (2) and take out the pulley (3) from the shaft.

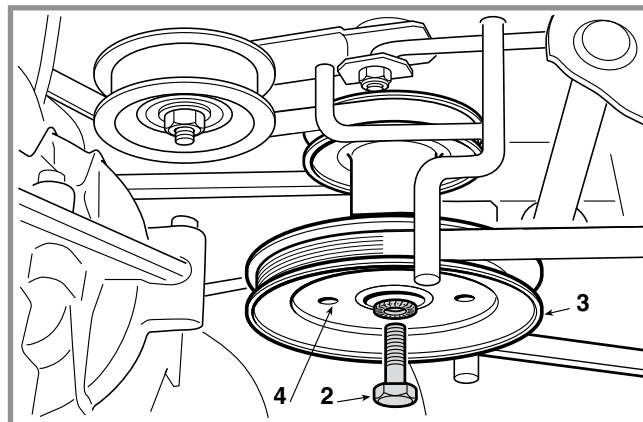

If it is difficult to take out, use the special extractor inserted into the holes (4) of the pulley, but do not completely undo the screw (2) so that the extractor puts pressure on the head of the screw and does not damage the threaded hole of the shaft.

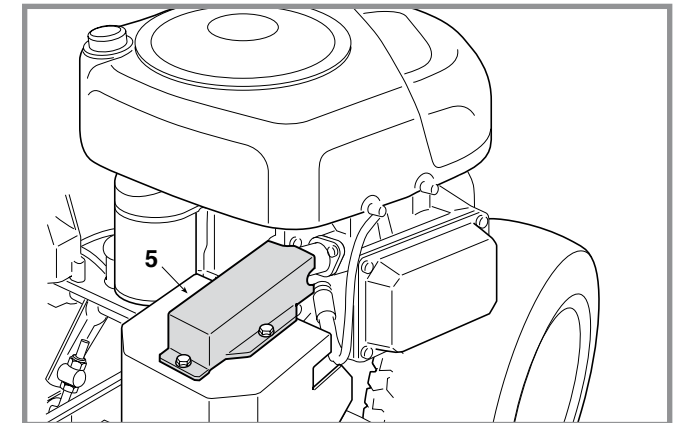
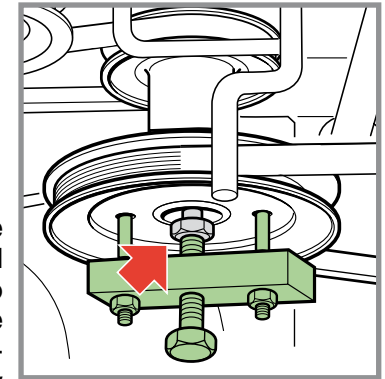

Remove the protection from the exhaust (5) (differing according to the types of engine), and disconnect the accelerator cable control and all the electrical wires.

⚠ Close the fuel cock and detach the fuel pipe, taking care not to spill fuel.

REMOVAL OF THE ENGINE

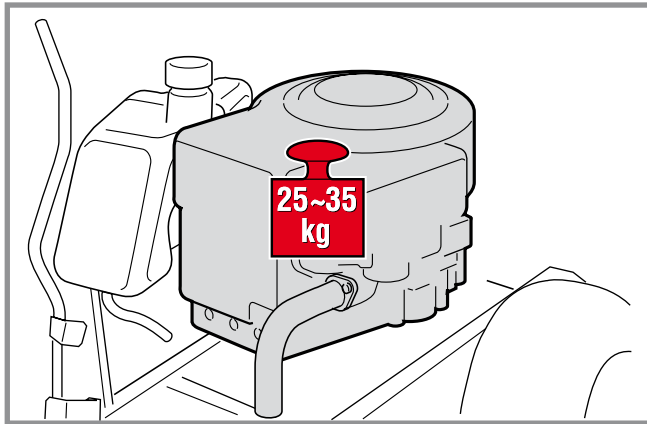

! Identify and undo all the screws that fasten the engine to the chassis, then carefully lift and remove the engine using equipment suitable for the weight of the engine (about 25-35 kg) and the designated lifting points to guarantee safe working conditions.

NOTE Some engines are held with screws of different length and in different positions, so it is best to label them so that no errors are made on reassembly.

For reassembly follow the operations described above in reverse.

Fully tighten the engine and pulley fixing screws to the prescribed values.

! Remember to fit the clamps back on the fuel pipe and check that it does not leak.

Reattach all the electrical and earth contacts and refit the protection covers (5).

► **hydrostatic drive models**
Refit the spring (1) of the stretcher.

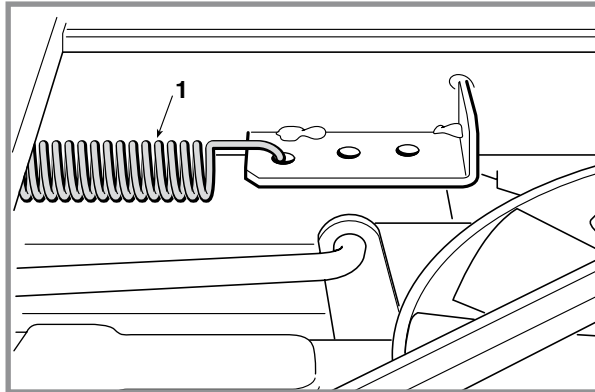

Reattach the accelerator cable and ...

- ☛ Adjust the «MINIMUM» position.
- ☛ Close up the wheels cover.

REMOVAL OF THE REAR AXLE
Peerless MST 205-541 E

CHAPTER	REVISION	FROM ...	PAGE
5.7	0	2018	1 of 2

General informations:

The rear axle (Transaxle) is made up of a single maintenance free sealed unit which includes the transmission unit (mechanical) and the differential and doesn't need any maintenance. It only needs to be removed to be replaced or for an overhaul by the Manufacturer's Service Centre.

Related topics

- [🔧 2.5] Opening the wheel cover
- [🔧 4.3] Brake adjustment
- [🔧 4.4] Drive lever adjustment
- [🔧 5.5] Removal of the collector channel
- [🔧 6.1] Removal of the wheels

Tightening torques

10	Self-tapping screws	25 ÷ 30 Nm
11	Screws for brackets	25 ÷ 30 Nm
13	Rear axle fastening nuts	25 ÷ 30 Nm

Map of functional units

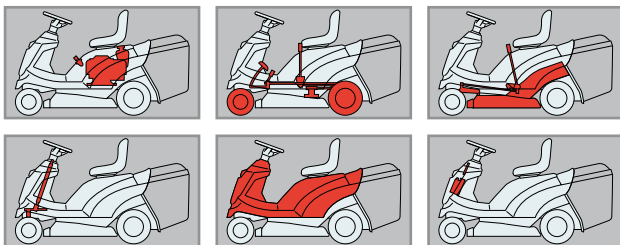

- 🔧 Lift the wheels cover.
 - 🔧 Dismantle the engine pulley to release the belt.
- Place two spacers (1) of approximately 150 mm under the two ends of the rear plate.

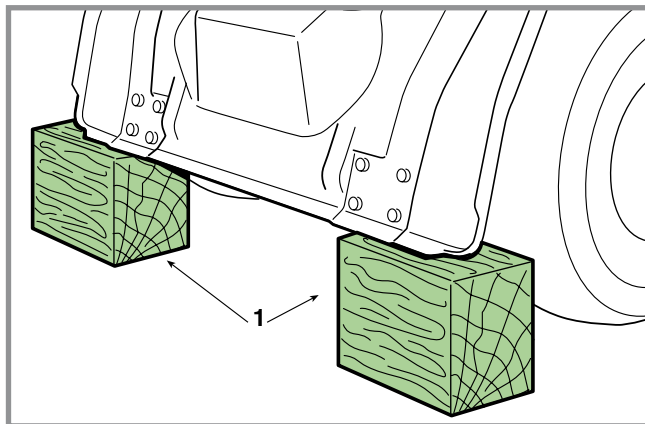

- 🔧 Remove the rear wheels.

Engage the parking brake to slacken off the transmission belt and remove the pin (2) from the brake rod (3).

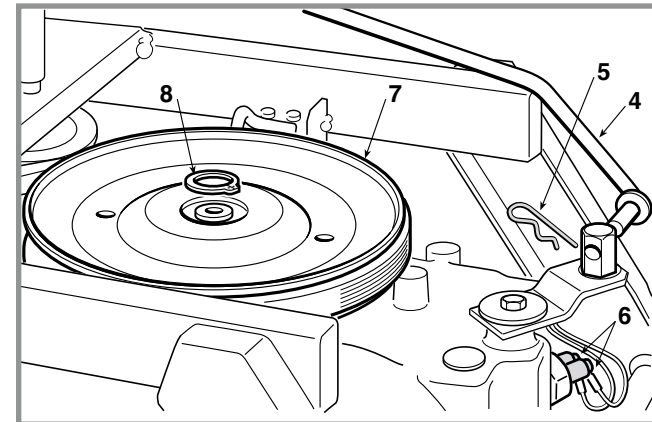
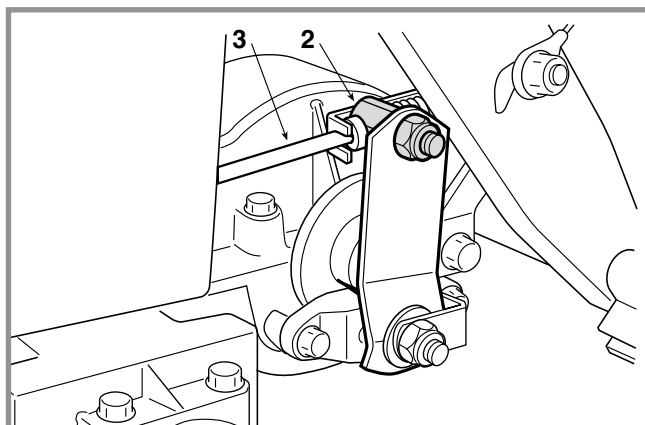

Disconnect the control rod (4) of the gear-change by taking out the split pin (5), and disconnect the wires of the microswitch (6) for signalling the "neutral" position.

Also dismantle the pulley (7) held by a snap ring (8).

The unit is supported by two brackets (9) – depending on the type used – with their screws (10) and (11) and is fastened to the frame (12) by four screws (13).

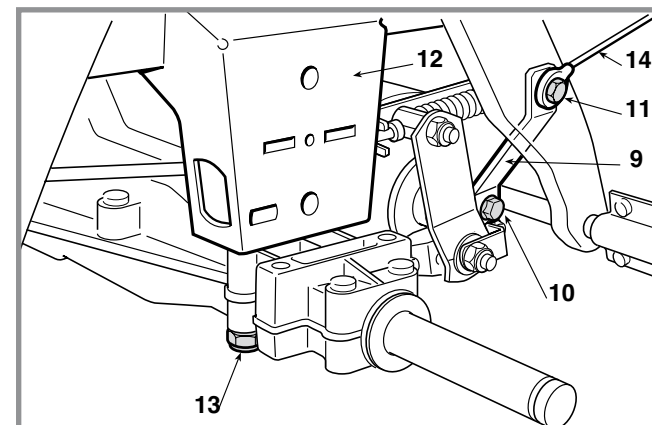

REMOVAL OF THE REAR AXLE Peerless MST 205-541 E

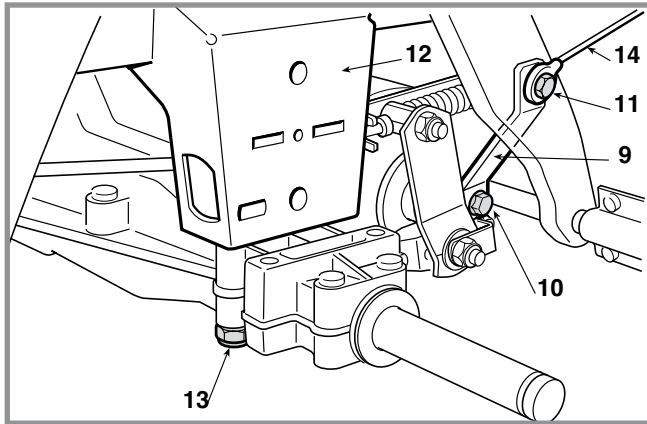

Loosen the screws (11) to permit a minimum of movement of the brackets (9) and undo the screws (10). Then carefully undo the four lower screws (13), giving sufficient support to the unit so that it does not fall, bearing in mind its weight of around 15 - 22 kg.

Reassemble in the reverse order, being particularly careful with the two self-tapping screws (10) which, if not screwed in correctly, can damage the internal thread preventing correct fastening.

NOTE When tightening the screw (11) on the left-hand side, be careful with the stop cable (14), which must always be taut and straight when the cover is open.

Check that the spacers (15) are correctly fitted to the shafts, in the sequence given.

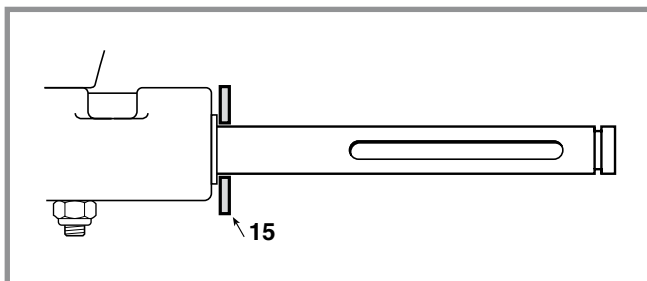

Reattach all the connections, and then ...

- ☛ Check the brake
- ☛ Refit the collector channel.
- ☛ Refit the rear wheels.
- ☛ Close up the wheels cover..

If the control rod has been replaced or completely dismantled...

- ☛ Adjust the travel and the position of "neutral" for the lever.

REMOVAL OF THE REAR AXLE
Tuff Torq K46T

General informations

The rear axle (Transaxle) is made up of a single maintenance free sealed unit which includes the transmission unit (hydrostatic) and the differential and doesn't need any maintenance. It only needs to be removed to be replaced or for an overhaul by the Manufacturer's Service Centre.

Related topics

- [🔧 2.5] Opening the wheel cover
- [🔧 4.3] Brake adjustment
- [🔧 4.4] Drive lever adjustment
- [🔧 5.5] Removal of the collector channel
- [🔧 6.1] Removal of the wheels

Tightening torques

25	Brake pin fastening nut	25 ÷ 30 Nm
32	Rear axle support nut	25 ÷ 30 Nm
33	Rear axle fastening nuts	25 ÷ 30 Nm

Map of functional units

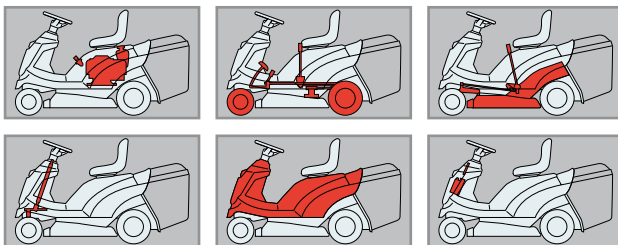

- 🔧 Lift the wheels cover.
 - 🔧 Dismantle the engine pulley to release the belt.
- Place two spacers (1) of approximately 150 mm under the two ends of the rear plate.

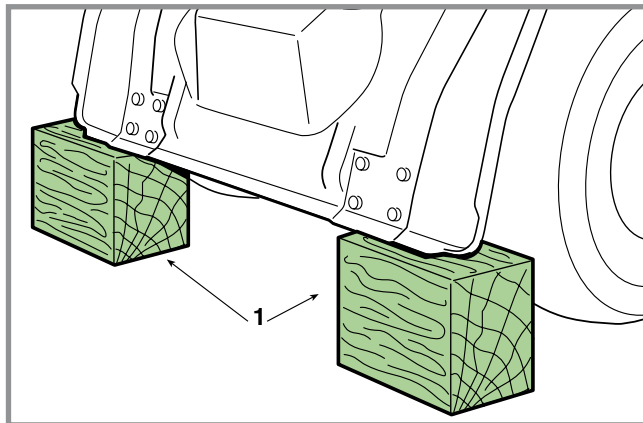

- 🔧 Remove the rear wheels.

Disconnect the drive control rod (21) by removing the split pin (22).

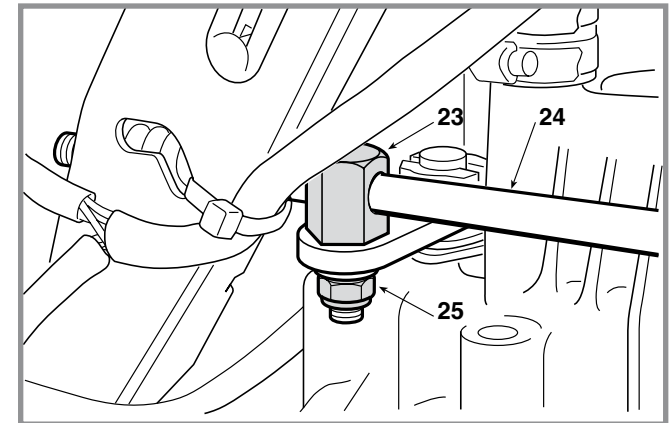
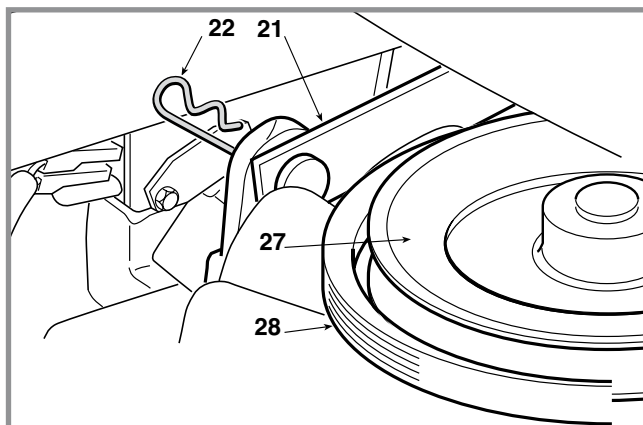

Remove the pin (23) from the brake rod (24) unscrewing nut (25).

Move the tensioner guide pulley (26) to the right and free the pulley (27) from the belt (28).

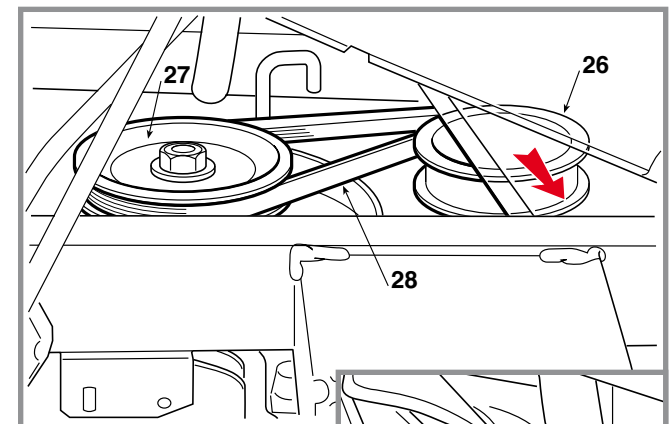

Disconnect the transmission release control rod (29), held by a bevel fastener (30).

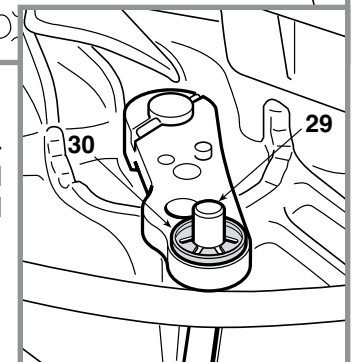

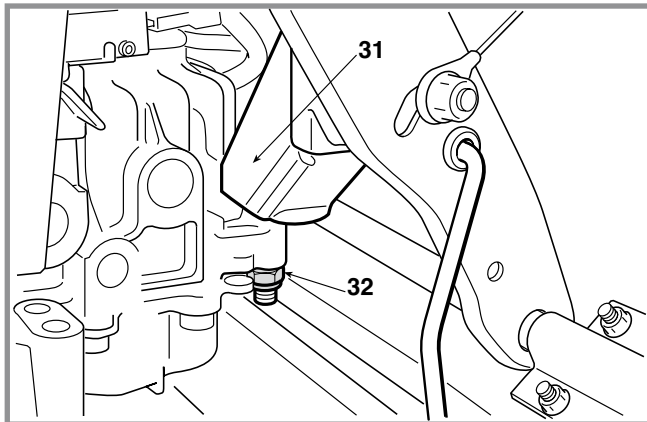

The group is supported by a support (31) fixed by a screw with nut (32) and is fixed to the chassis by four screws with relative nuts (33).

Unscrew nut (32), then carefully unscrew the nuts (33) of the four lower screws, suitably supporting the group so it cannot fall and taking account of the weight of approximately 20 - 22 kg.

Carry out the above operations in reverse to reassemble.

NOTE When the transmission release control rod (29) is reconnected, the bevel fastener (30) must always be replaced since it is damaged during dismantling.

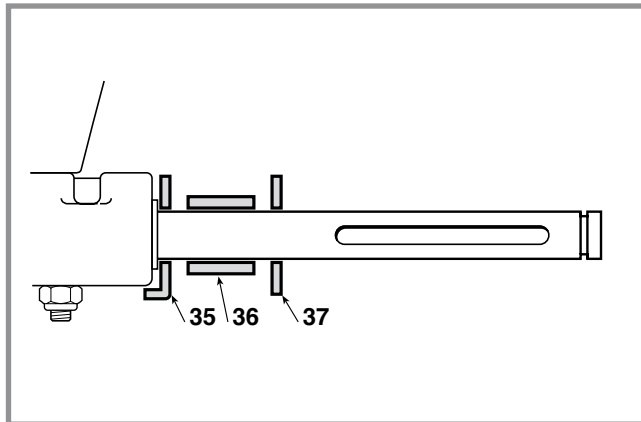
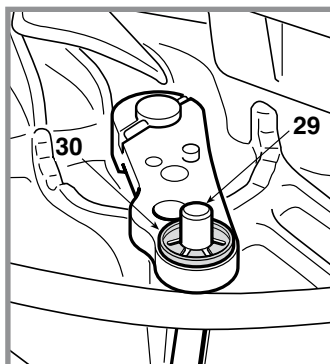

Check that the spacers (35 - 36 - 37) are correctly fitted to the shafts, in the sequence given.

Reattach all the connections, and then ...

- ☛ Check the brake
- ☛ Refit the collector channel.
- ☛ Refit the rear wheels.
- ☛ Close up the wheels cover..

If the control rod has been replaced or completely dismantled...

- ☛ Adjust the travel and the position of "neutral" for the lever.

REMOVAL OF THE REAR AXLE
Hydro Gear T2-BDBE-2X1A-16X1

CHAPTER	REVISION	FROM ...	PAGE
5.7b	0	2018	1 of 2

General informations

The rear axle (Transaxle) is made up of a single maintenance free sealed unit which includes the transmission unit (hydrostatic) and the differential and doesn't need any maintenance. It only needs to be removed to be replaced or for an overhaul by the Manufacturer's Service Centre.

Related topics

- [🔧 2.5] Opening the wheel cover
- [🔧 4.3] Brake adjustment
- [🔧 4.4] Drive lever adjustment
- [🔧 5.5] Removal of the collector channel
- [🔧 6.1] Removal of the wheels

Tightening torques

14-16 Screws for support fastening .. 25 ÷ 30 Nm

15 Rear axle fastening nut 25 ÷ 30 Nm

Map of functional units

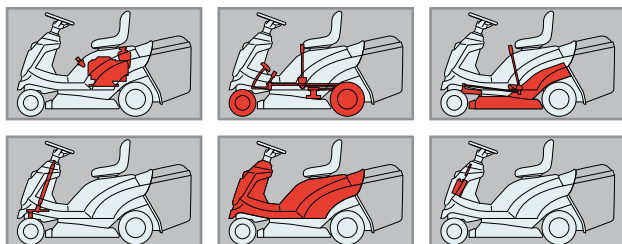

- 🔧 Lift the wheels cover.
 - 🔧 Dismantle the engine pulley to release the belt.
- Place two spacers of approximately 150 mm under the two ends of the rear plate.

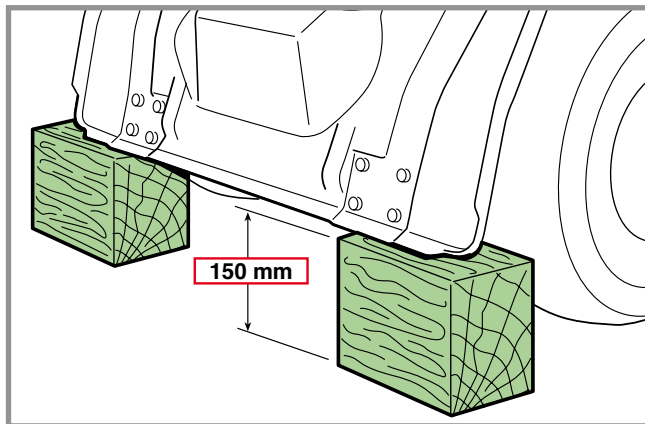

- 🔧 Remove the rear wheels.

Remove the split pin (1) and remove the front pin (2) from the brake rod.

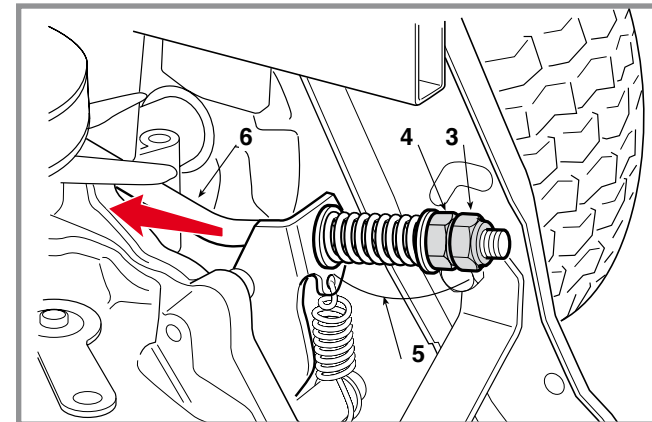
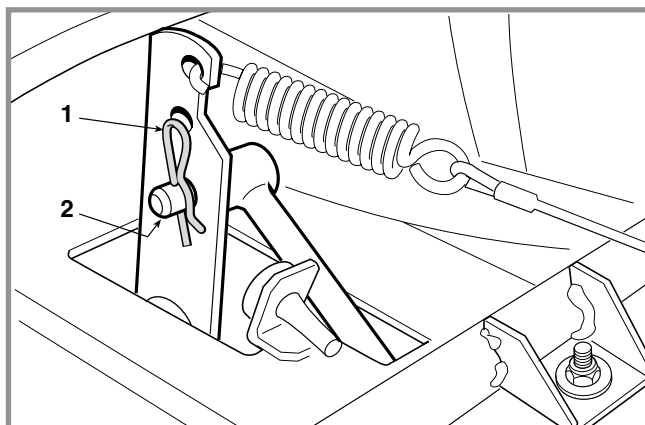

Unscrew the nuts (3) and (4) and remove all the brake adjuster unit components (5) so that the rod (6) is free to slide forward.

Release the plate (7) and slide the pin (8) out to disconnect the drive control rod (9)

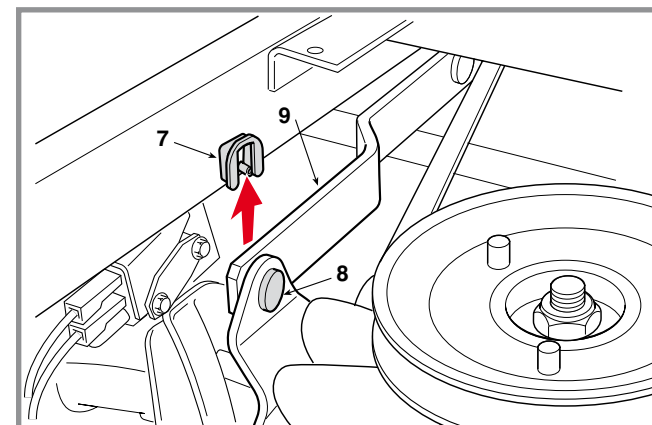

REMOVAL OF THE REAR AXLE
Hydro Gear T2-BDBE-2X1A-16X1

CHAPTER	REVISION	FROM ...	PAGE
5.7b	0	2018	2 of 2

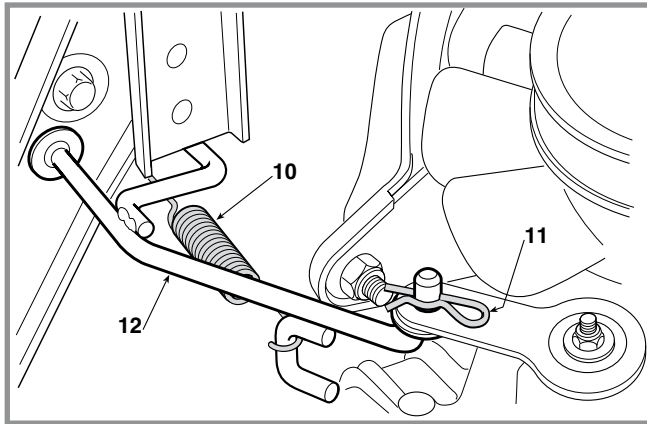

Release the spring (10), slide off the splint pin (11) and disconnect the transmission release control rod (12).

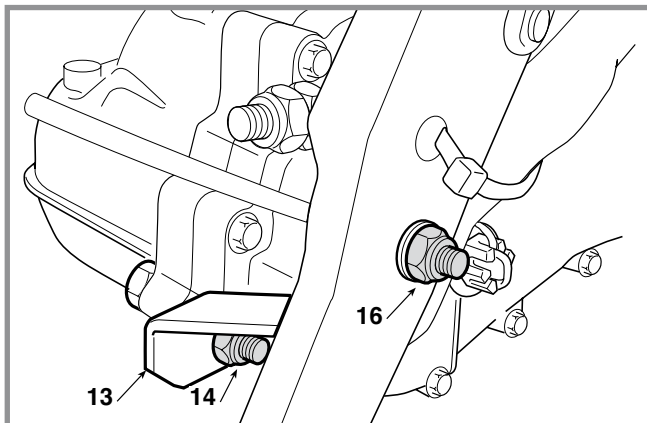

The group is supported by a support (13) fixed by a screw with nut (14) and is fixed to the chassis by four screws with relative nuts (15).

Loosen the nut (16) to allow a minimum of movement for the support (13), unscrew the nut (14), then carefully unscrew the nuts (15) on the four lower screws,

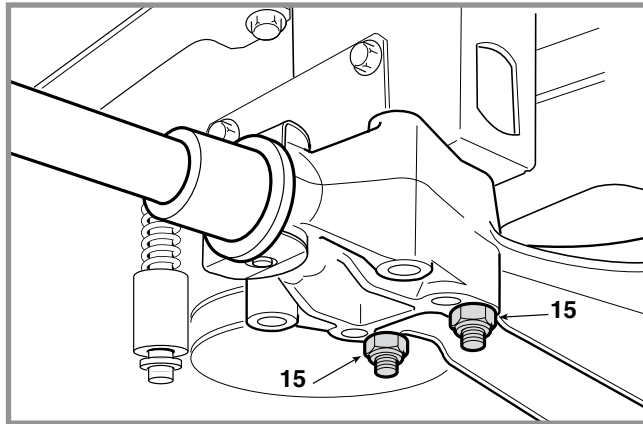

suitably supporting the group so it cannot fall and taking into account it weighs approximately 15 - 22 kg.

To reassemble, reverse the order of the previous operations.

Check that the spacers (17 - 18) are correctly fitted to the shafts.

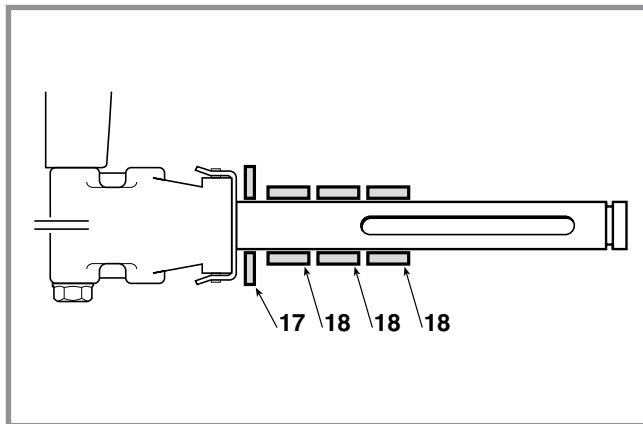

Reattach all the connections, and then ...

- ☛ Check the brake
- ☛ Refit the collector channel.
- ☛ Refit the rear wheels.
- ☛ Close up the wheels cover..
- ☛ Adjust the travel and the position of “neutral” for the lever.

REMOVAL OF THE CUTTING DECK

General informations

Removing the cutting deck facilitates all the overhaul and replacement of hub, bearings and blade shaft.

With some practice and experience it is possible to do this work with the deck still in position.

Related topics

[🔧 4.5] Aligning the cutting deck

[🔧 5.6] Removing the engine

Map of functional units

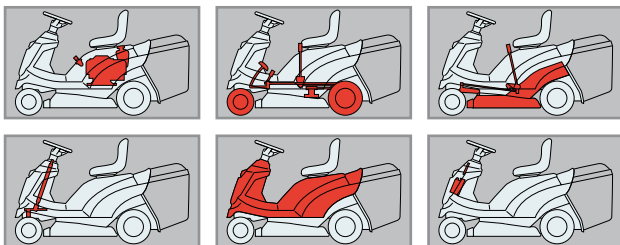

🔧 Dismantle the engine pulley to release the belt.

Remove the left and right side guards.

Pull out the external split pin (1) through the inspection hole in front of the seat and remove the pin (2) from the inside, in order to disconnect the collector channel (3).

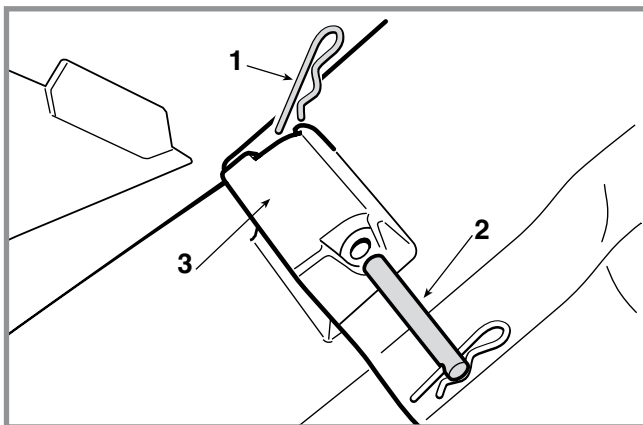

Bring the cutting deck to position «1».

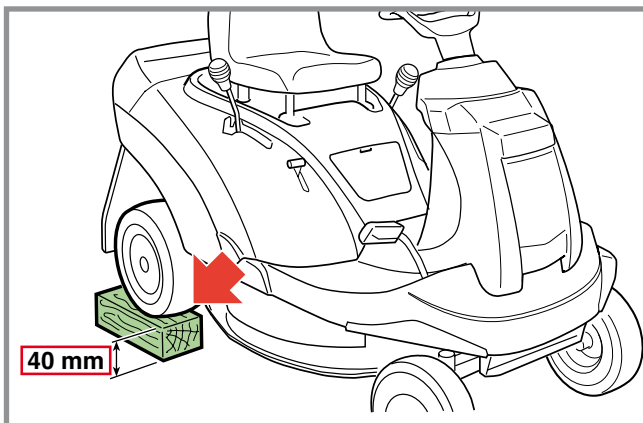

Put a 40 mm block underneath the rear right wheel.

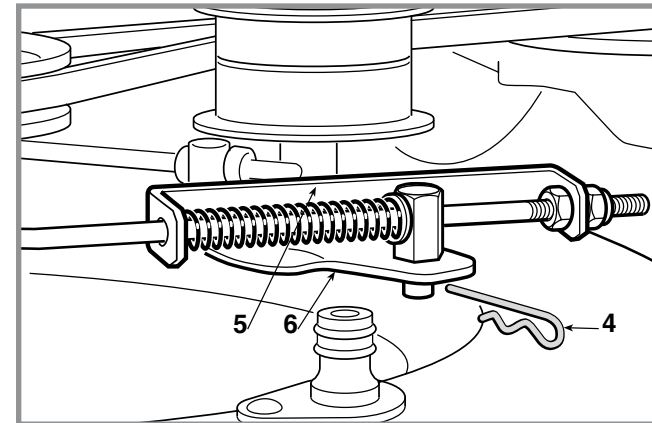

Pull out the split pin (4) in order to disconnect the entire bracket (5) from the blade engagement lever (6).

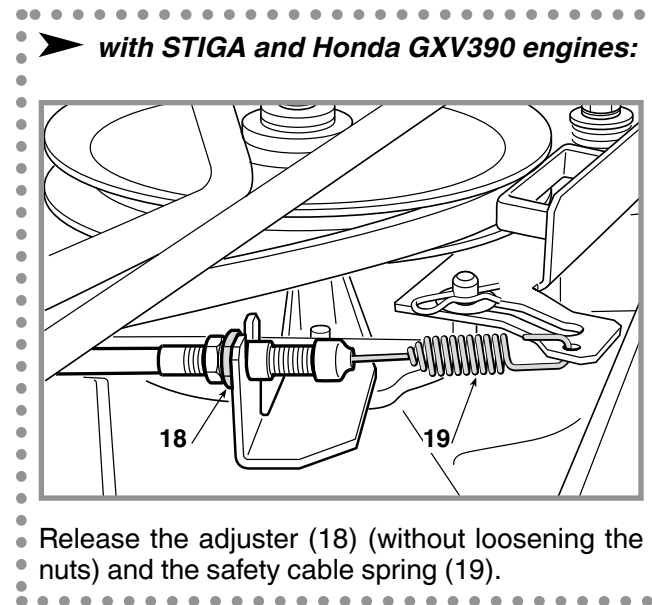

Release the adjuster (18) (without loosening the nuts) and the safety cable spring (19).

REMOVAL OF THE CUTTING DECK

CHAPTER	REVISION	FROM ...	PAGE
5.8	2	2018	2 of 2

➤ *mechanical drive models:*

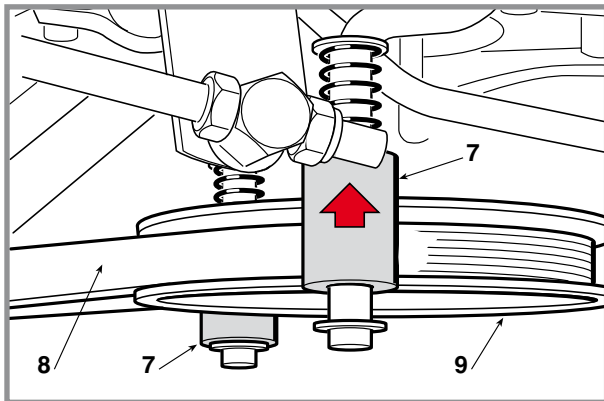

Slide the two belt shifter bushes (7) up until the belt (8) is released from the engine shaft pulley (9).

Unscrew the nut (10) in order to pull the pin (11) out of the front left lifting lever (12).

Pull the elastic split pin (13) of the pin (14) in the rear right lever (15) and the elastic split pin (16) fastening the pin to the front right lever (17).

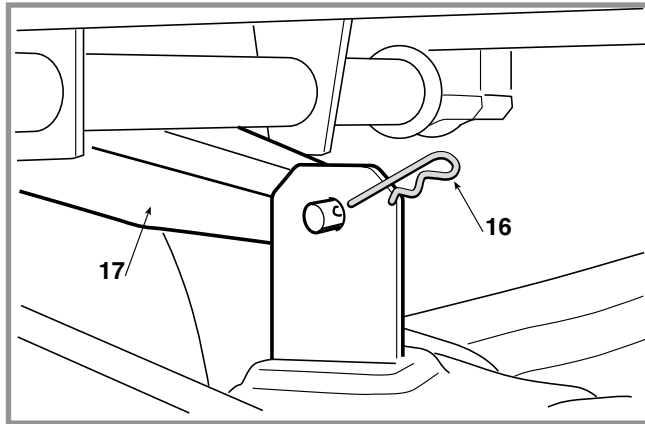

Take care not to touch the nuts and lock-nuts so that they remain aligned for assembly.

After checking that there is nothing in the way, the deck can be removed, first by rotating it slightly to the left so that all the pins come out of their housings. Then take it out from the right-hand side.

On assembly, first remove the block underneath the rear right wheel.

Check that the pin (11) moves freely.

☛ Refit the engine pulley.

☛ Check the alignment of the cutting deck.

⚠ WARNING! *Reassemble the right and left side guards.*

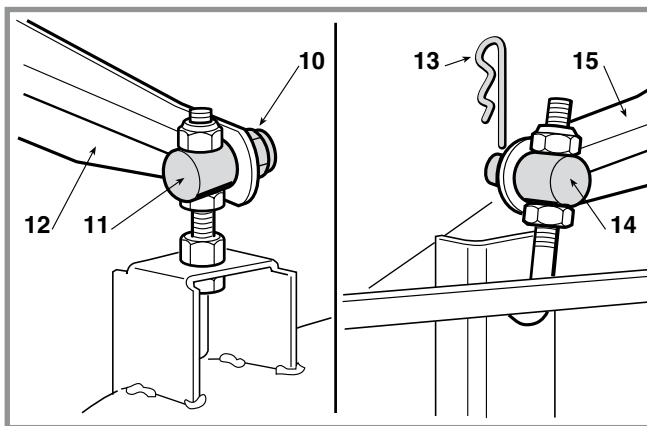

REPLACEMENT OF TYRES AND WHEELS

CHAPTER	REVISION	FROM ...	PAGE
6.1	0	2018	1 of 1

General informations

Tyres used can be:

- "Tubeless" type,
- with air chamber,

and so every repair of a hole in the tyre must be done by a tyre specialist according to the methods used for each type of tyre.

Related topics

[🔧 2.3] Lifting of the machine

[🔧 4.5] Aligning the cutting deck

Tyre pressures

Front	1,5 Bar
Rear	1,0 Bar

Map of functional units

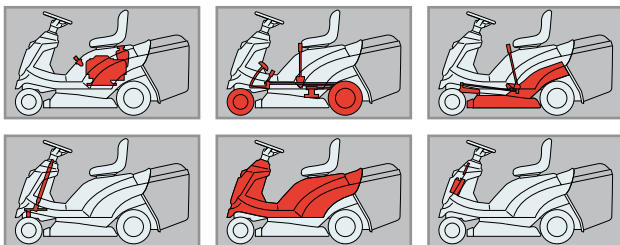

A) Tyres

After replacing one or more tyres or the wheels, it is always necessary to check the pressure and to check the alignment of the cutting deck.

⚠ WARNING! Replace distorted wheel rims as they could impair the tyre's hold.

B) Wheels

The wheels are held by a snap ring (1) which can be removed with the help of a screwdriver.

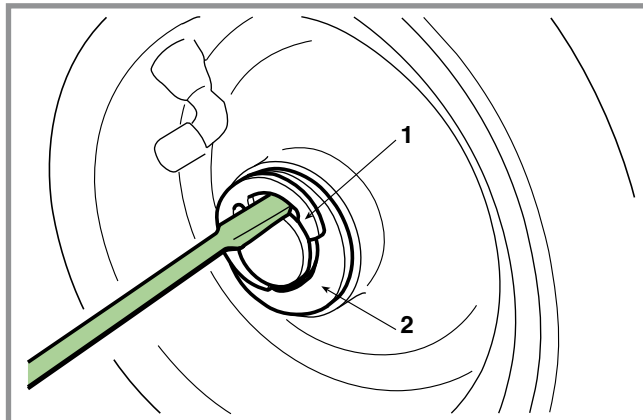

NOTE If a wheel is jammed onto the shaft, use a releasing spray, directing it around the splining hole.

On assembly it is advisable to spread grease on the shaft to facilitate the next wheel removal.

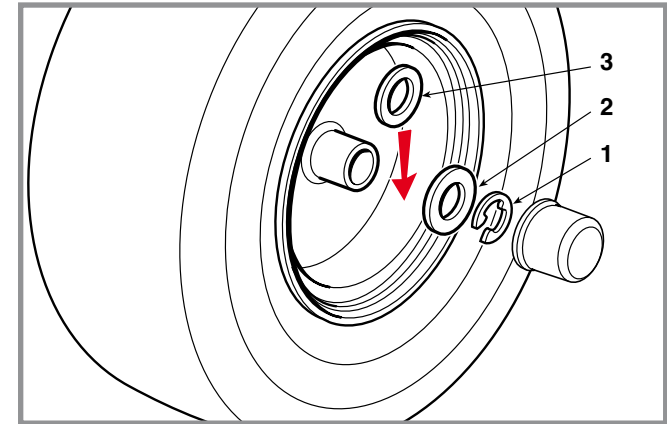

● **For the front wheels:** replace the shoulder washer (2) and the flexible ring (1) with the bevel facing inwards.

● **For the rear wheels:** replace the shoulder washer (2) and the flexible ring (1) with the bevel facing inwards and check the axial gap of the wheel on the shaft; if it is greater than 3 mm, a spacer (3) must be fitted between the wheel hub and the shoulder washer (2).

NOTE For tyres with air chamber, install a spacer (4) at the inner side of the wheel.

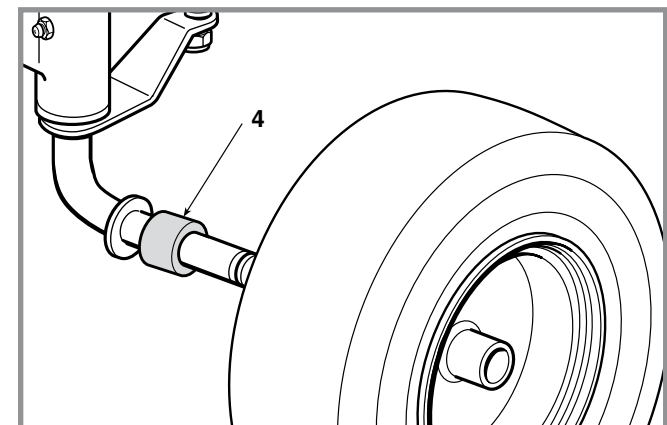

General informations

Related topics

[🔧 2.2] Tools

[🔧 2.3] Lifting of the machine

[🔧 6.1] Replacement of tyres and wheels

Map of functional units

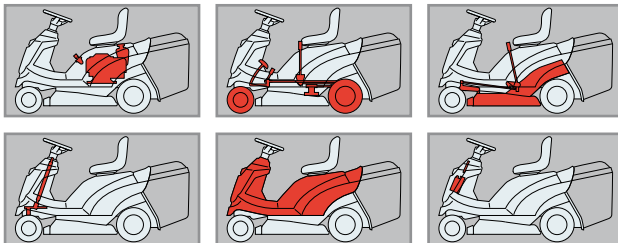

🔧 Dismantle the front wheel.

The front wheel bearings (1) are force splined into the front wheel hub.

A 10 - 12 mm diameter round bar (2) must be used to extract a bearing, inserted from the opposite side and struck with a hammer around various points of the inner circumference of the bearing.

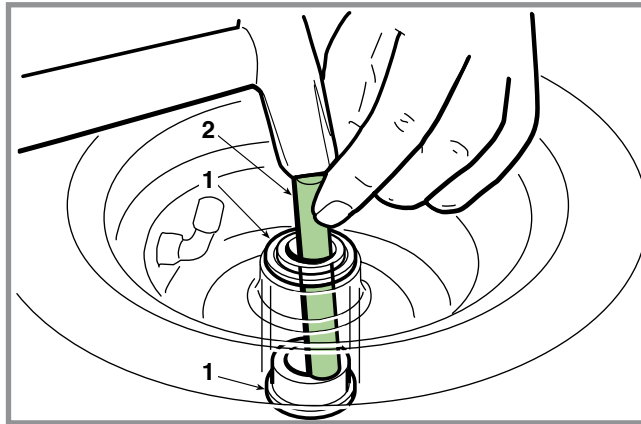

The new bearing must be fitted with the help of a plastic mallet or of a bronze pad (3) that only acts on the bearing's outer ring.

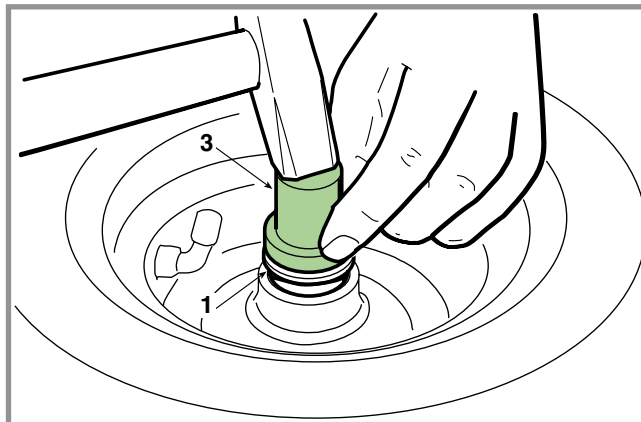

General informations

Related topics

[🔧 4.6] Steering allowance adjustment

[🔧 4.7] Steering geometry adjustment

Map of functional units

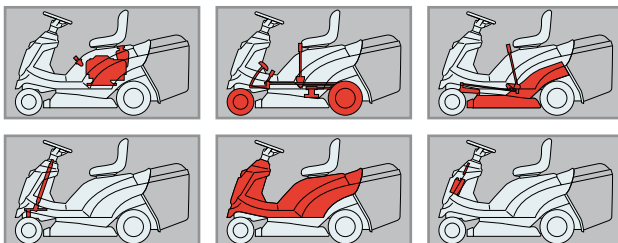

A) Dismantling the steering pinion and ring gear

- 🔧 Follow the procedure as that for adjusting the steering allowance.

B) Dismantling the steering shaft

Dismantle the pinion and the ring gear as described at point "A".

Take out the snap ring (1) from its seat in the shaft (2) and extract the shaft from the bushings (3) pulling it downwards.

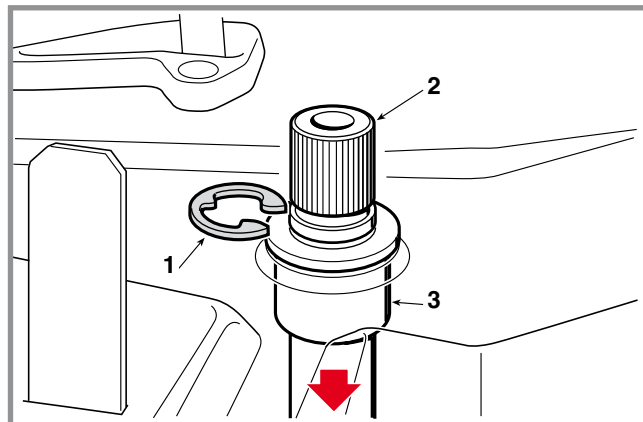

IMPORTANT *On reassembly, take note that with a new pinion and ring gear it is not necessary to insert spacers in-side the hub.*

- 🔧 Adjust the steering allowance
- 🔧 Check the steering geometry

REPLACEMENT OF THE DRIVE BELT

General informations

Related topics

[🔧 2.5] Opening the wheel cover

[🔧 4.11] Drive belt adjustment

[🔧 5.6] Removing the engine

[🔧 8.2] Belts assembly

Tightening torques

3 Pulley fixing nut 25 ÷ 30 Nm

Map of functional units

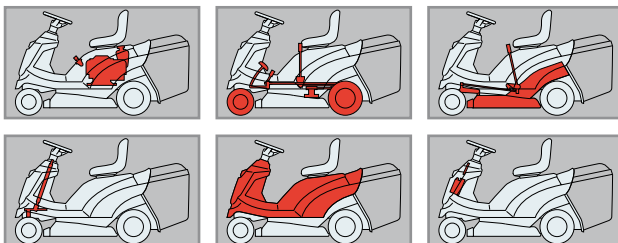

🔧 Dismantle the engine pulley to release the belt.

🔧 Lift the wheels cover.

Loosen the transmission belt. To do this:

➤ **mechanical drive models**

Engage the parking brake.

➤ **hydrostatic drive models**

Release the spring (1) of the stretcher.

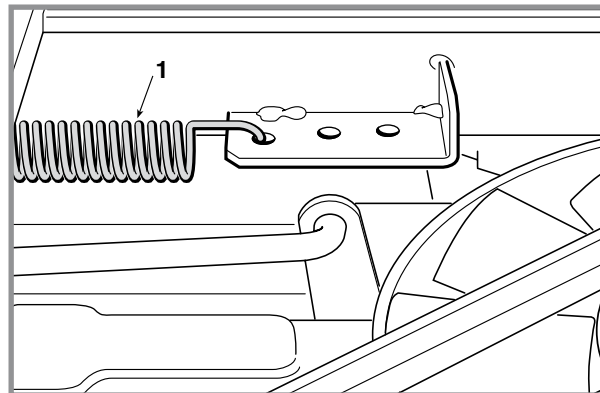

Dismantle the pulley of the stretcher (2), held by the nut (3).

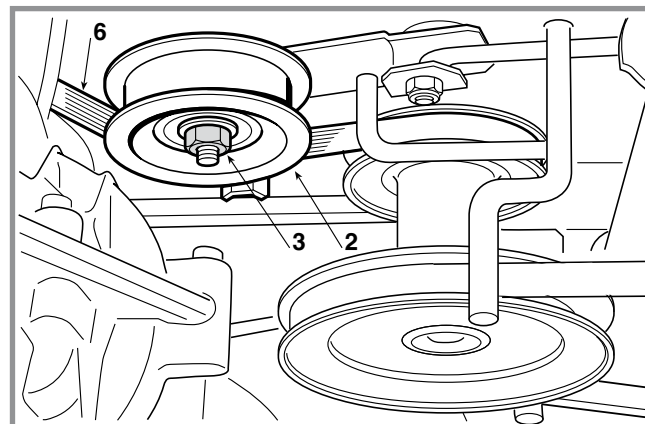

➤ **mechanical drive models**

Remove the snap ring (4) and lift the pulley (5) just enough to free the belt (6).

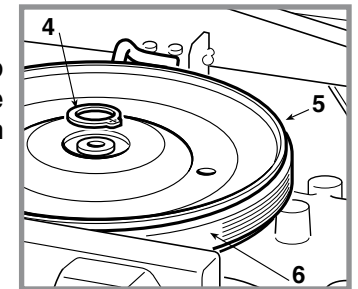

The belt (6) can now be removed from the pulley (5).

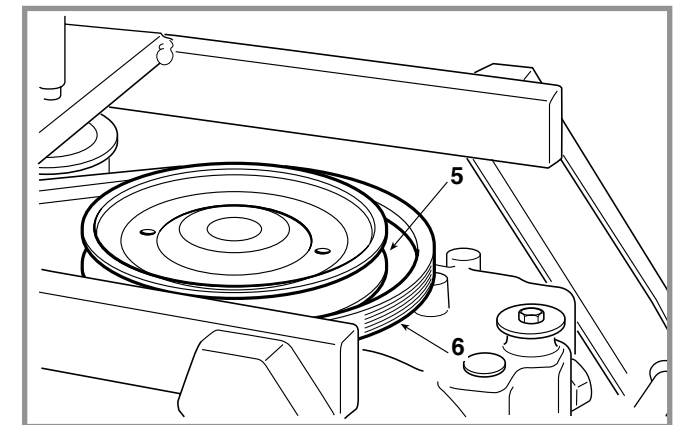

On reassembling, make sure that the belt (6) is correctly positioned in the pulleys inside the rims.

When assembly is completed, ...

🔧 Close up the wheels cover.

🔧 Refit the engine pulley

➤ **mechanical drive models**

🔧 Adjust the drive engagement

REPLACEMENT OF THE BLADE BELT

General informations

Related topics

[4.1](#) Blade engagement adjustment

[4.2](#) Blade brake adjustment

[5.6](#) Removing the engine

[8.2](#) Belts assembly

Tightening torques

5 Guide pulley nut	25 ÷ 30 Nm
8 Blade pulley screw	25 ÷ 30 Nm

Map of functional units

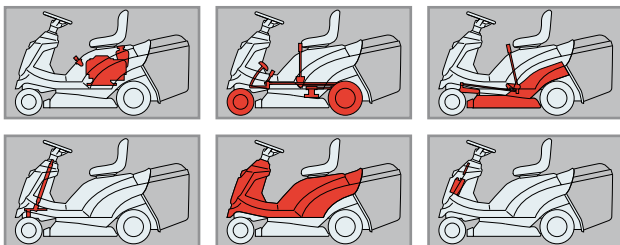

mechanical drive models:

Slide the two belt shifter bushes (3) up until the belt (2) is released from the engine shaft pulley (1).

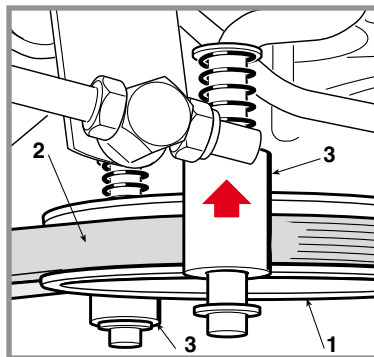

hydrostatic drive models:

Dismantle the engine pulley (1) to release the belt (2).

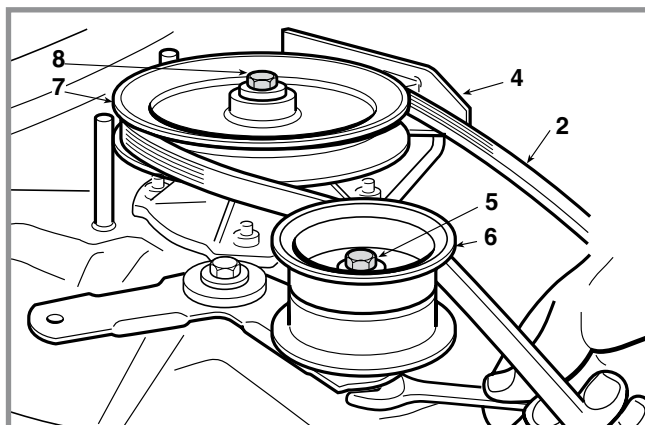
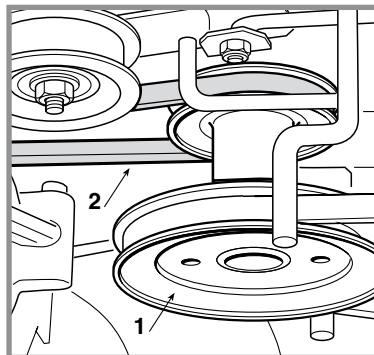

Remove the left and right side guards.

Put the blade engagement lever in the engaged position to free the brake (4).

with STIGA and Honda GXV390 engines:

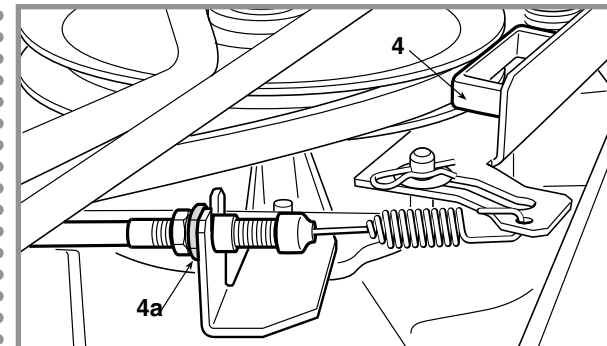

Release the adjuster (4a) (without loosening the nuts) to free the brake (4).

Loosen the screw (5) in order to move the stretcher pulley (6) until the belt (2) is released, without unscrewing it completely.

Dismantle the pulley (7) of the blade shaft attached by the screw (8).

At this point the belt can be taken out and replaced.

On reassembling, take care to exactly position the new belt in the pulley rims.

WARNING! Reassemble the right and left side guards.

Once assembly is completed ...

Adjust the blade engagement.

Check that the blade brake is working properly.

REPLACEMENT OF THE SUPPORT AND SHAFT OF THE BLADE

CHAPTER	REVISION	FROM ...	PAGE
6.6	0	2018	1 of 2

General informations

Related topics

[🔧 2.2] Special tools

[🔧 4.9] Removing, sharpening and balancing the blade

[🔧 5.8] Removal of the cutting deck

Tightening torques

3 Blade pulley screw. 25 ÷ 30 Nm

5 Flanged support fixing nuts..... 25 ÷ 30 Nm

Map of functional units

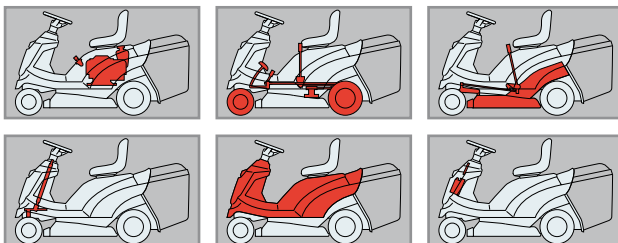

🔧 Remove the left and right side guards

🔧 Remove the cutting deck.

NOTE *This operation is not strictly necessary since, with a little practice and experience, it is possible to dismantle the deck supports without removing the deck. If not removed it would be best to put the deck into a middle position for easy access both above and below..*

🔧 Remove the blade and take off the hub.

Put the blade engagement lever into the engaged position to free the brake (1), or manually move the brake (1) away.

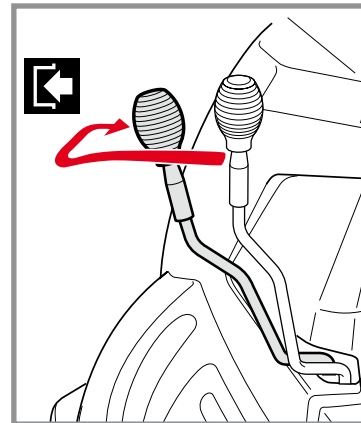

Dismantle the pulley (2) from the blade shaft, attached by the screw (3).

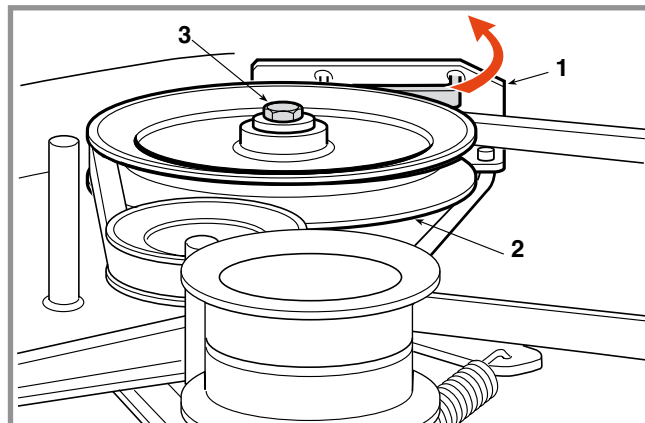

A) Replacement of the support of the blade

Dismantle the flanged support (4) by unscrewing the four fixing screws (5).

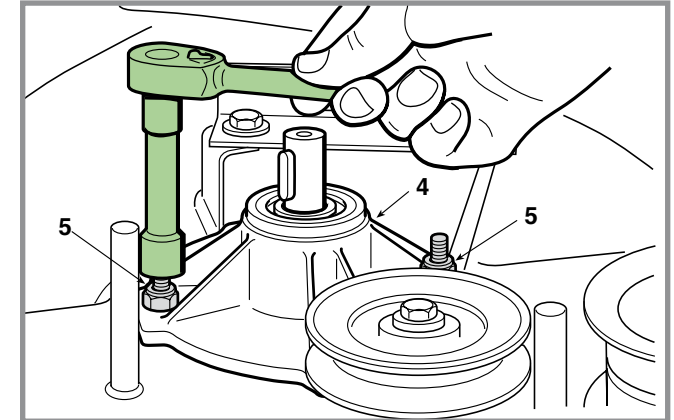

NOTE - *The entire support (4), including shaft and bearings, is a spare part available as a single assembly unit.*

Fit the flange support onto the deck, fully tightening the nuts (5).

On completion of assembly of the support, ...

🔧 Reassemble the hub and start sharpening, balancing and assembling the blade.

🔧 Reassemble the cutting deck.

⚠️ Always reassemble the side safety guards.

B) Replacement of the bearings and the shaft of the blade

Remove the key (6) and hit the shaft with a plastic mallet on the pulley side in order to remove the shaft together with the lower bearing (7).

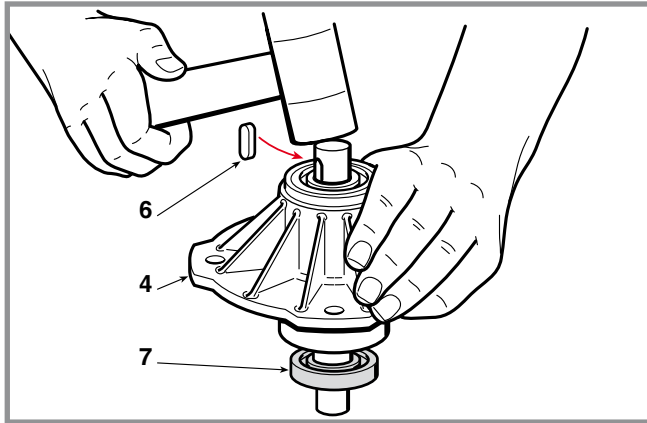

After having removed the Sieger ring (8), the dust cover (9) and the key (6), the bearing (7) splined onto the shaft can be removed using a normal extractor, taking care to close up the threaded hole (11) with a screw to prevent the point of the extractor from damaging the thread.

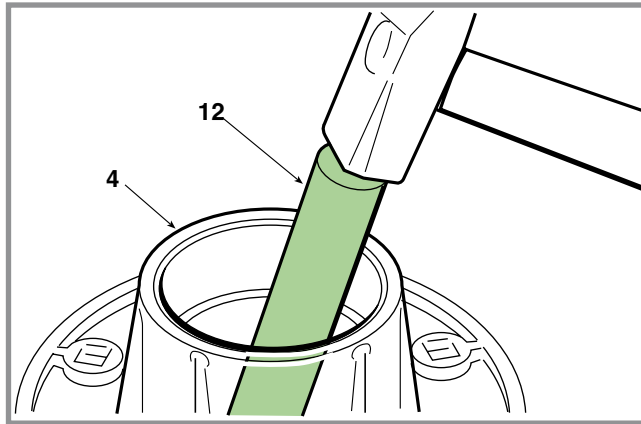
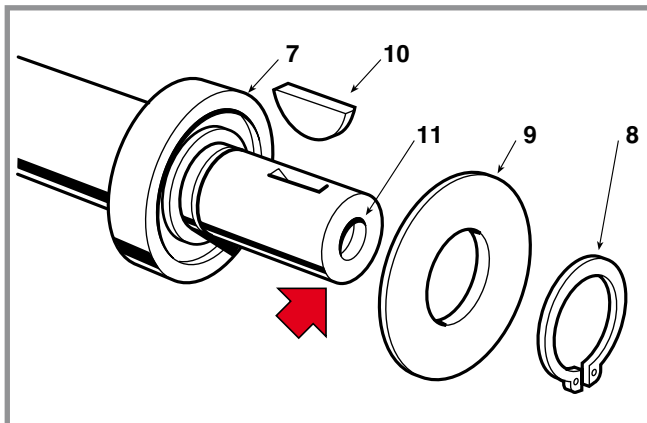

The second bearing still in place must be removed by hitting it from the inside of the flange using a 12 ÷ 15 mm diameter round bar (12).

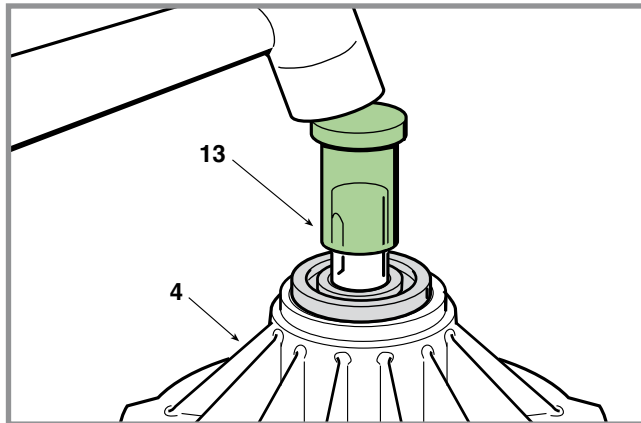

On reassembling, first put the shaft into the hole of the lower bearing and insert this into the support. Fit on the upper bearing and, using the special bush (13) which works on the inner ring, hit it squarely with a mallet until the bearing is fully driven home.

Fit the flange support onto the deck, fully tightening the nuts (5).

General informations

Related topics

[🔧 2.5] Opening the wheel cover

Map of functional units

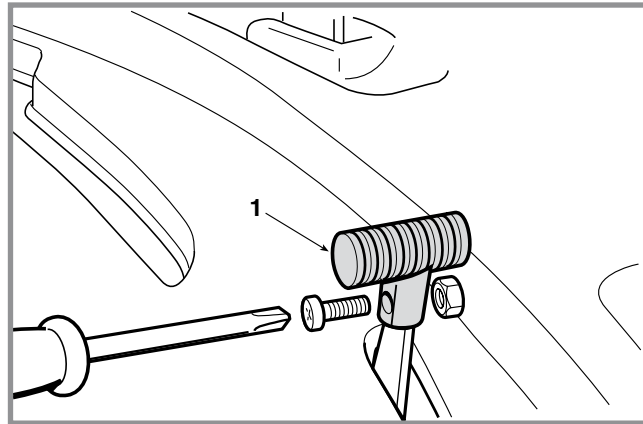
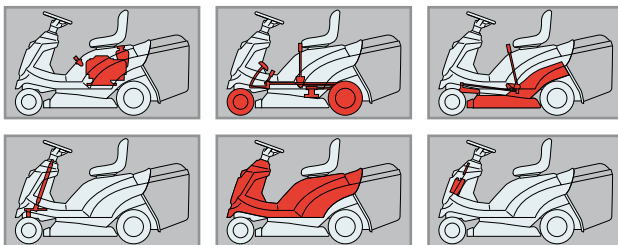

Take the small knob (1) off the accelerator.

🔧 Lift the wheels cover.

Disconnect the end of the cable (2) from the coupling terminal (3) on the engine.

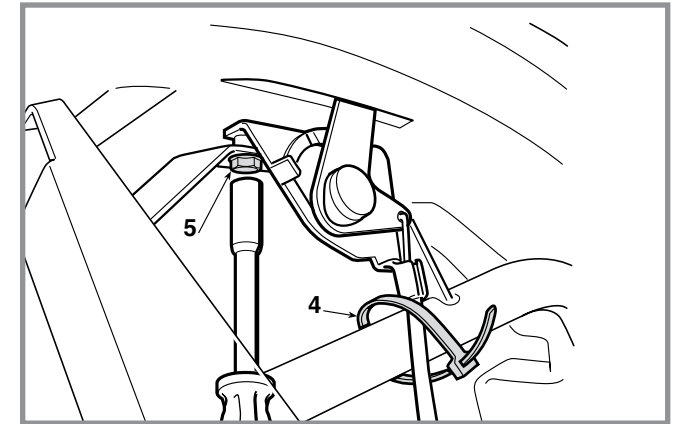
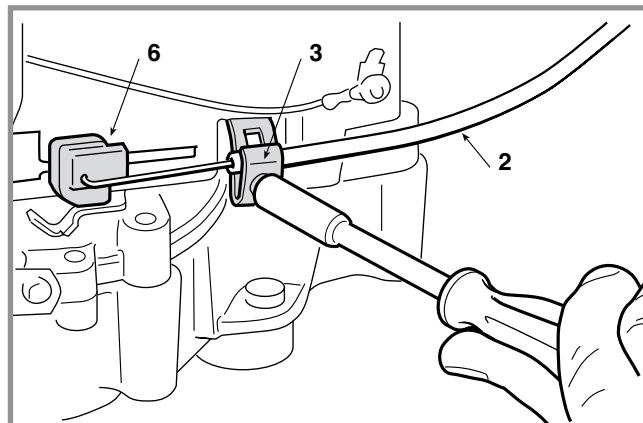

Remove the clamp (4), undo the two screws (5) and take out the accelerator together with the cable.

On reassembling, put the accelerator lever in the «MINIMUM» position shown on the label, connect the end of the wire (2) to the terminal (3) on the engine after having moved the cursor (6) in the same «MINIMUM» position specific to each type of engine and shown in the instruction handbook.

Put back the clamp (4).

When assembly is completed, ...

🔧 Close up the wheels cover.

REPLACEMENT OF THE DRIVE LEVER UNIT

CHAPTER	REVISION	FROM ...	PAGE
6.8	0	2018	1 of 2

General informations:

Related topics

[🔧 2.5] Opening the wheel cover

[🔧 4.4] Drive lever adjustment

[🔧 5.5] Removal of the collector channel

Tightening torques

11 Drive lever support screws 25 ÷ 30 Nm

Map of functional units

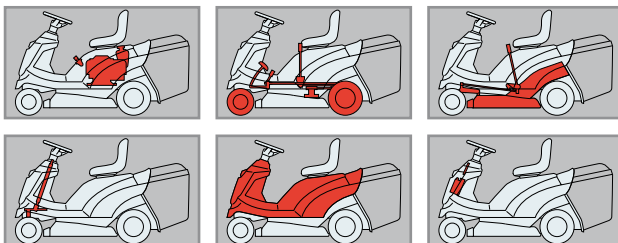

- 🔧 Lift up the wheels cover.
- 🔧 Remove the collector channel.

With the pedal released, detach the rod (1) connecting to the rear axle by unscrewing the nut of the pin (2), and the rod (3) connecting to the pedal by unscrewing the nut of the pin (4).

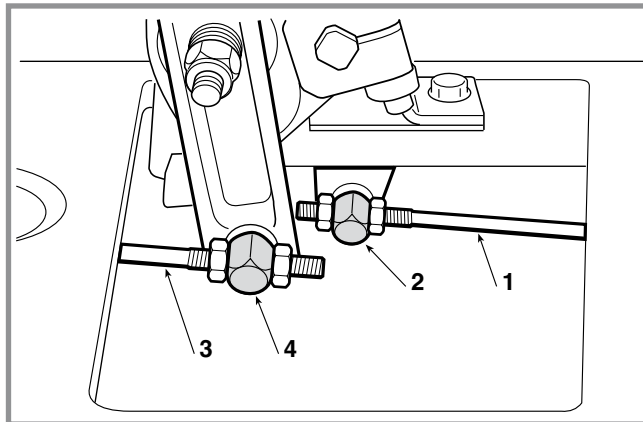

Unhook the barrel (5) and detach the return cable (6).

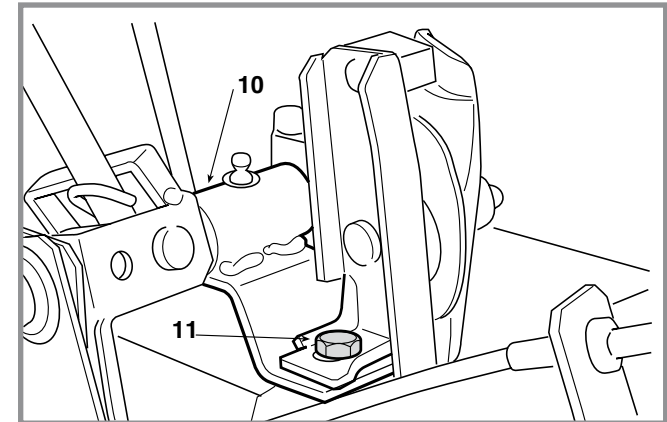
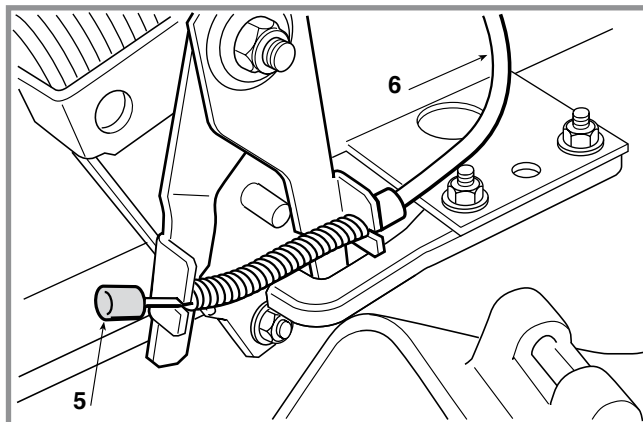

Unscrew the two screws (11) and remove the support (10) with the whole lever unit.

NOTE - The whole unit is available as a spare part in a single assembly unit.

Fit the new unit keeping it to the right, fixing it using the two screws (11).

Hook the barrel (5) of the cable (6) and refit the pins (2) and (4) without fully tightening their nuts, and after having loosened the adjuster nuts of the rods (1) and (3).

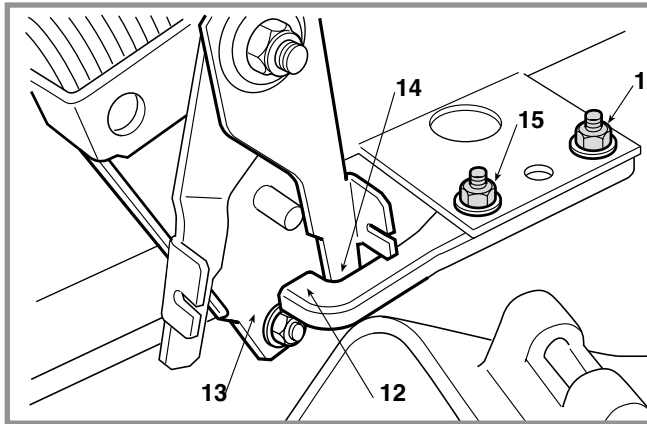

Check that the end (12) of the hook is positioned in a way that does not impede the lever's (13) travel and that it stops the movement of the lever (14).

If necessary, only loosen the back screw (15) and move the terminal (12) just enough to achieve the condition described above.

If you accidentally loosen both screws (15) and (16), thus losing their original position, you need to

- ☛ Adjust the stop

When this has been done

- ☛ Find the lever's "neutral" position.
- ☛ Adjust the release rod for the clutch device.
- ☛ Adjust the lever's return cable.

After all adjustments have been made, ...

- ☛ Refit the collector channel.
- ☛ Close up the wheels cover.

REPLACEMENT OF THE LEVER RETURN
CABLE

General informations:

Related topics

[🔧 2.5] Opening the wheel cover

[🔧 4.4] Drive lever adjustment

[🔧 5.5] Removal of the collector channel

Map of functional units

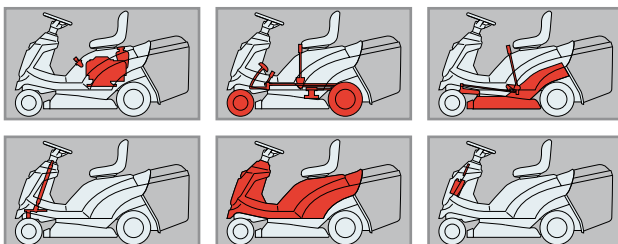

- 🔧 Lift up the wheels cover.
- 🔧 Remove the collector channel.

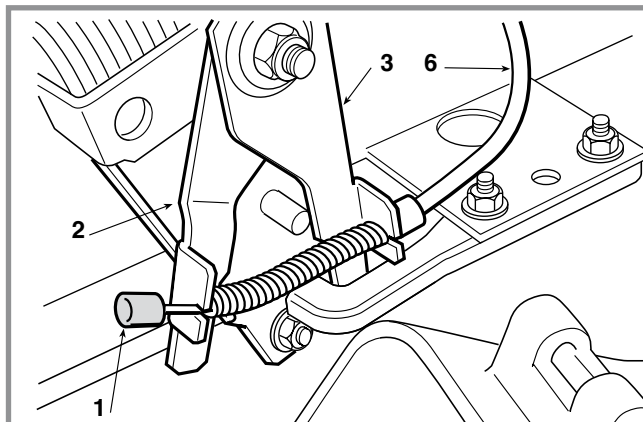

With the pedal released, unhook the barrel (1) from the lever (2), take it off the lever (3), loosen the nut (4) of the adjuster, release the spring (5) and remove the cable (6).

Start fitting the spring (5) using the upper hole of the lever (7) and then completing the operations described before in reverse order.

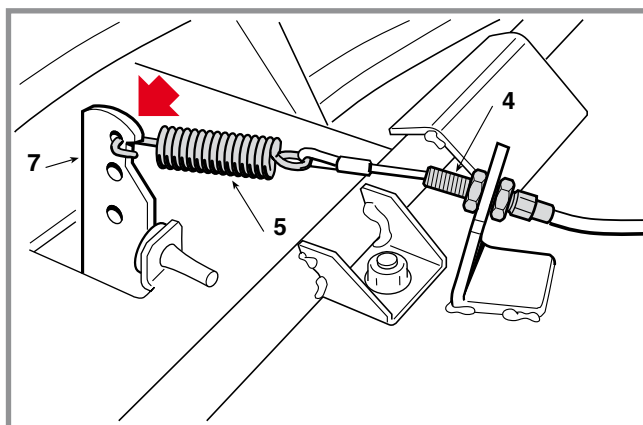

When fitting is completed,

- 🔧 Adjust the cable.
- 🔧 Refit the collector channel.
- 🔧 Close up the wheels cover.

REPLACEMENT OF THE FRICTION DISCS FOR CLUTCH DEVICE

General informations:

The friction discs can lose efficiency if they get dirty with oil or grease, or if they are accidentally lubricated by the user, in which case they must be replaced.

Related topics

- [🔧 2.5] Opening the wheel cover
- [🔧 4.4] Drive lever adjustment

Tightening torques

6 Drive lever sector nut	10 ÷ 15 Nm
--------------------------------	------------

Map of functional units

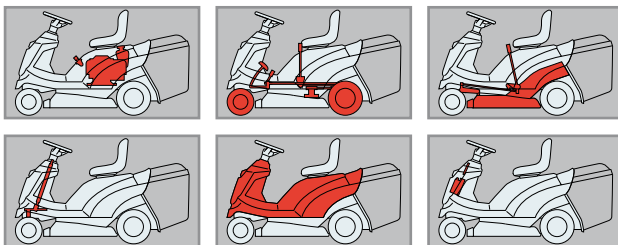

🔧 Lift up the wheels cover.

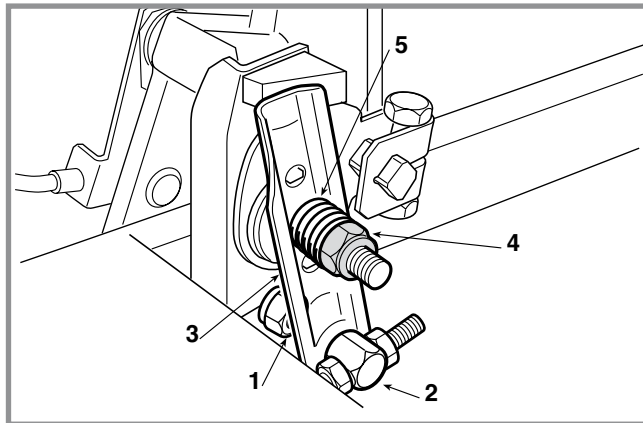

Unscrew the nut (1) and dismantle the pin (2) from the lever (3). By unscrewing the nut (4), you can take out the spring (5) and the lever (3).

Loosen the nut (6) so that the sector (7) can slide along and be taken off the square shaft (8) together with the two friction discs (9) and the two steel discs (10).

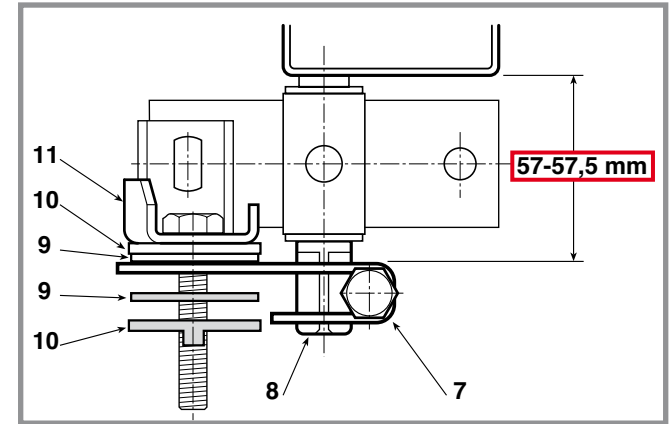
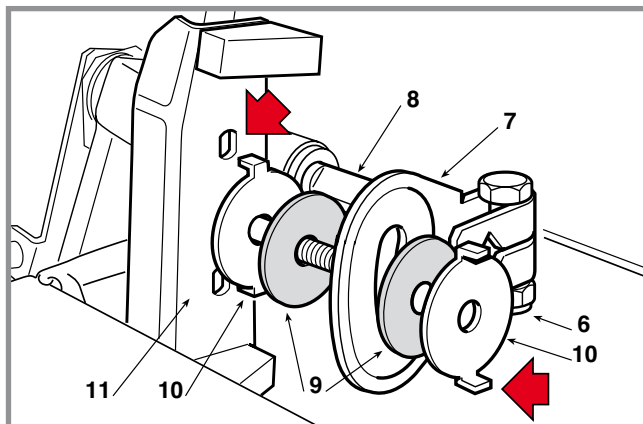

When reassembling, carry out the operations described above in reverse order, making sure that the two tabs of the steel discs are correctly positioned in the recesses made in the lever (3) and on the support bracket (11), and ensuring that the sector (7) is pushed down on the shaft (8) until the recommended distance of 57 - 57.5 mm is achieved.

When fully assembled ...

- 🔧 Adjust the release rod.
- 🔧 Adjust the spring.
- 🔧 Close up the wheels cover.

General informations:

Related topics

[🔧 2.5] Opening the wheel cover

[🔧 5.5] Removal of the collector channel

Map of functional units

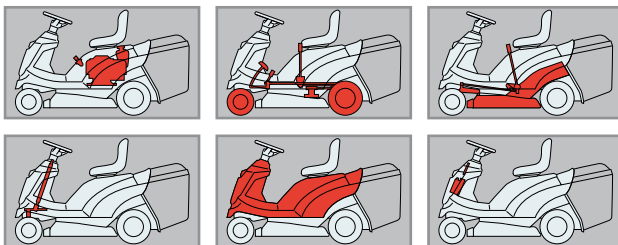

➤ with STIGA and Honda GXV390 engines:

- 🔧 Lift up the wheels cover.
- 🔧 Remove the collector channel.

Release the adjuster (1) of the cable (2) and the spring (3).

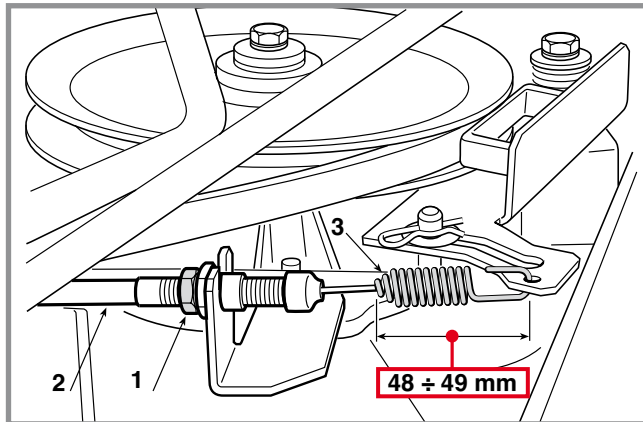

Remove the clamp (4) behind the rear left wheel.

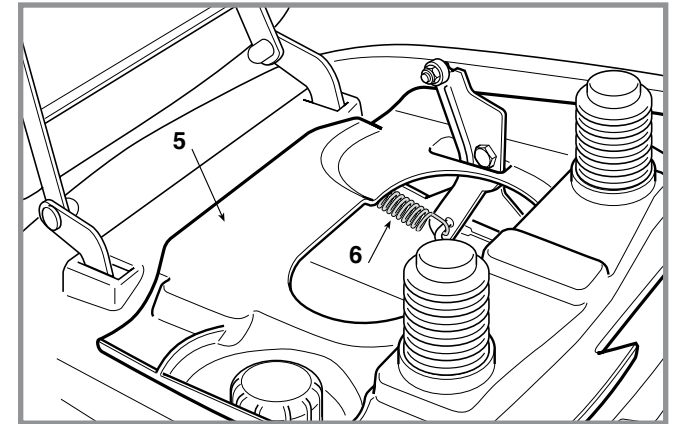
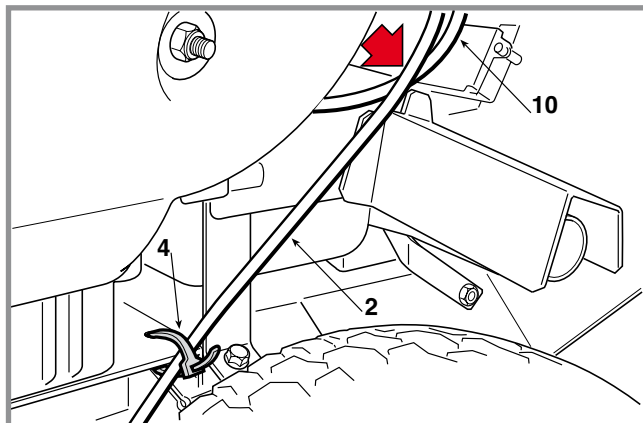

Remove the guard (5) under the seat and unhook the spring (6).

Remove the crown fastener (7) and disconnect the cable (2) terminal (8).

At this point, the cable (2) can be removed, extracting it from below.

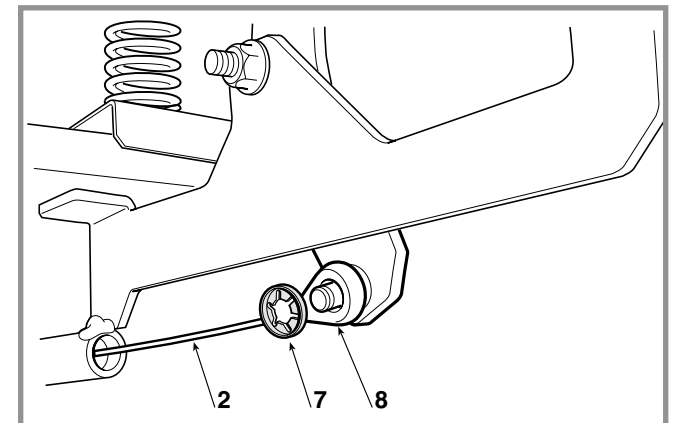

REPLACEMENT OF THE SEAT'S SAFETY
CABLE

When mounting, reverse the operations described above, taking care to:

- always replace the crown fastener (7);
- pass the cable (2) under the guiding jumper next to the pulley (9);

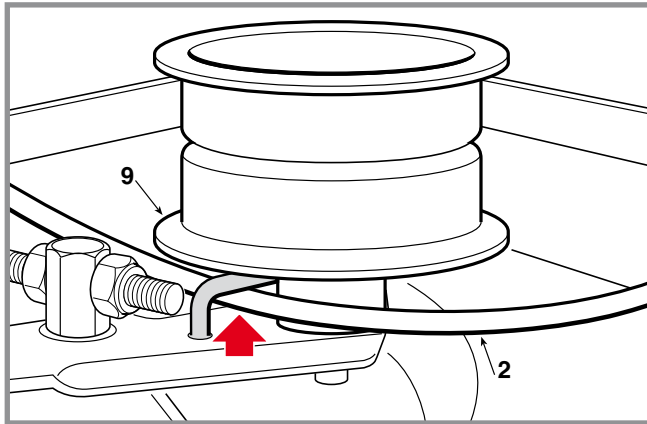
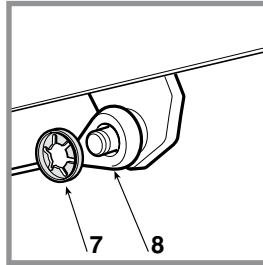

- remount the clamp (4) making sure that the cable (2) passes over the accelerator cable (10) and is well taut between the seat spring and the clamp (with the wheel cover raised).

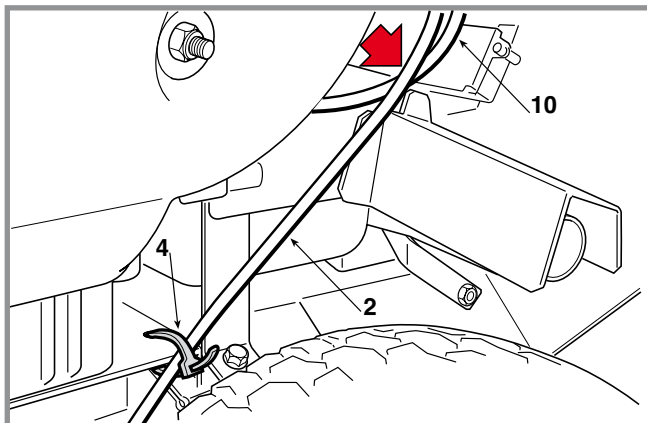

After attaching the adjuster (1) and the spring (3), regulate the adjuster (1) until the spring (3) is 48 - 49 mm long with the blade disengaged.

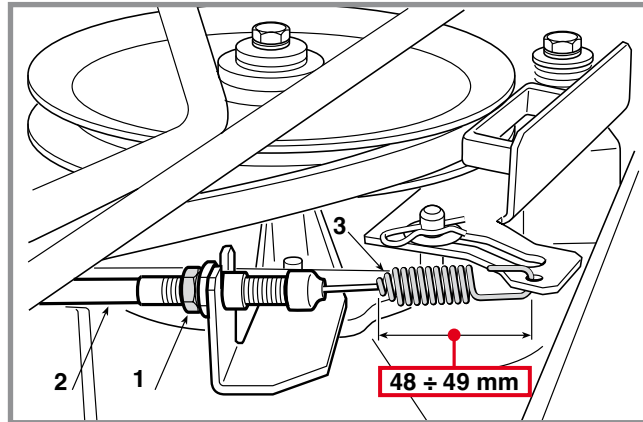

- ☛ Reattach the collector channel.
- ☛ Close up the wheels cover.

General informations:

Related topics

[🔧 4.3] Brake adjustment

[🔧 6.1] Removal of the wheels

Map of functional units

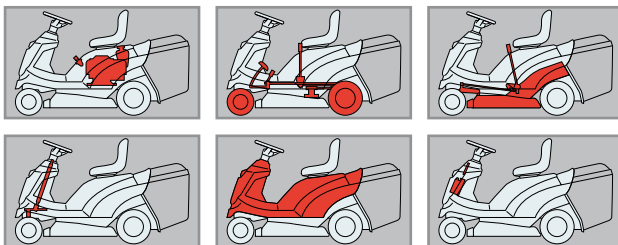

➤ *mechanical drive models:*

🔧 Remove the left-hand rear wheel.

Dismantle the pin (1) from the lever (2) and undo the two screws (3) which hold on the support (4).

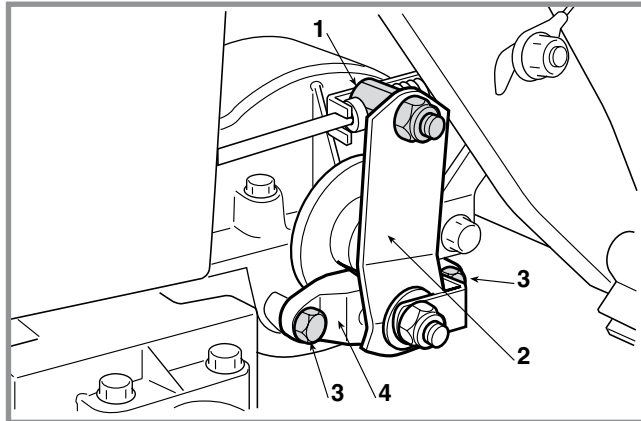

The support (4) contains a pad (5a) separated from the control pistons (6) by a plate (7).

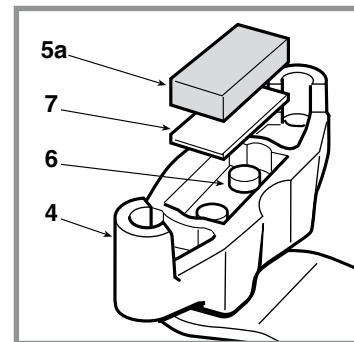

The other pad (5b) can be reached by taking off the disc (8).

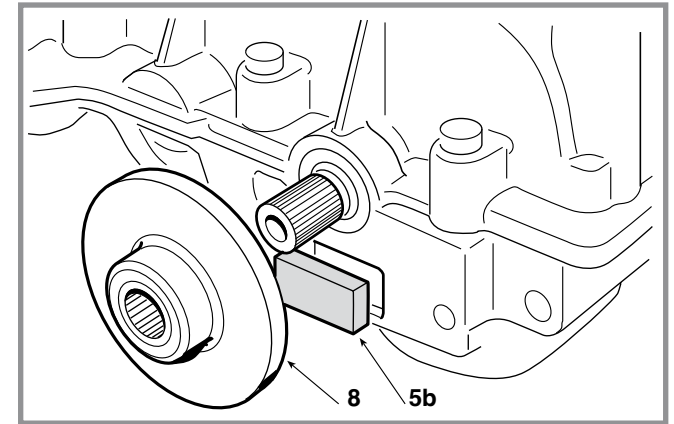

On reassembling, carefully reposition all the components and refit the complete support.

NOTE During all these operations it is better to not unscrew or loosen the central screw (9) to avoid altering the calibration of the cam driving the pistons.

If it has been moved...

🔧 the lever's free movement will have to be checked.

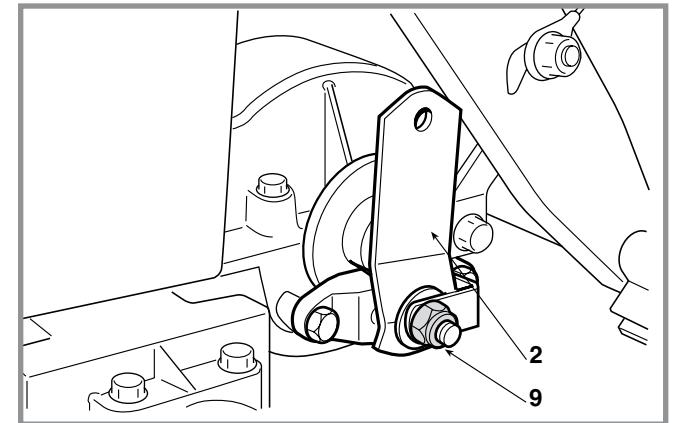

If there is oil on the pads, clean with solvent and go over them with fine-grade abrasive paper.

⚠ Both pads should be replaced if the depth of either of them is less than 5 mm.

⚠ Renew the disc if it is damaged, distorted or less than 4 mm thick.

When fully reassembled ...

🔧 Check the brake adjustment.

General informations

In the following some of the problems connected to the malfunctioning of the electrical system are shown, with their probable cause and the remedial action to be taken. Should the problem continue after the appropriate checks, seek assistance from your local Service Centre.

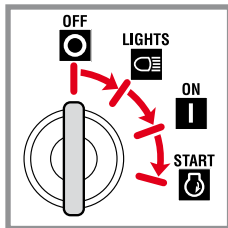

Related topics

- [7.2](#) Table for the cutting in of the safety devices
- [7.3](#) Safety microswitches operation check
- [7.4](#) Terminal board supply check
- [7.5](#) Starter relay operation check
- [7.6](#) Electronic card operation check
- [7.7](#) Recharge circuit check
- [7.8](#) Maintenance of the sealed battery

Map of functional units

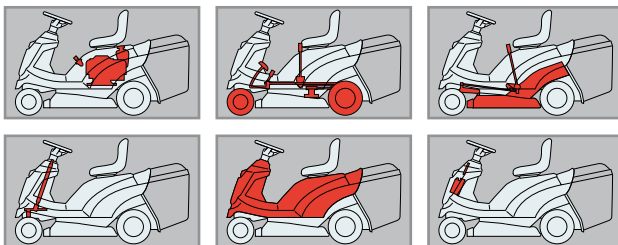

PROBLEM	CAUSE	REMEDY
1. Activation of the self-resetting protection 1)		
a) ... on inserting the key in position «ON»	Battery terminal crossed	Check the battery connections
	Short circuit to earth	Check the connectors and wiring of the microswitches
b) ... in position «START» or after a few seconds use, following an attempt at starting with outside means:	Sulphated battery (it no longer accepts recharging)	Replace the battery
	Faulty or wet electronic card	Check and dry with low pressure tepid air (hair-dryer)
	Disconnected or missing battery	Reconnect the battery. It must always be connected
	Battery terminals corroded or with poor contact	Check and clean the connections
c) ... after several minutes' use:	Poor or missing earth contact on the charge regulator	Check the earth connections and the screws fastening the regulator
	Overvoltage from a malfunction in the regulator	Check the recharge circuit
	Battery disconnected or faulty during use	Check the battery or wiring
2. With the key in the «ON» position the pilot lamp remains off	The battery is not supplying the card	Check the connection cables Check the battery's condition
	Battery or card not earthed to frame	Check and put right
	10 A fuse blown	Replace fuse (10 A)
	Battery terminal crossed	Check connections

! WARNING! The self-setting guard reaches very high temperatures (around 160 °C) which are to be considered normal. Similarly, there might be some smoke inside the box which is due to the overheating of the powder inside. **Do not touch this component of the circuit board until it has cooled down.**

1) Activation of the self-resetting protection of the electronic card is signalled by the failure of the LED to light, by it switching off during work, by the engine running erratically or stopping.

IMPORTANT Faulty electronic cards must always be replaced without trying to repair them or replace single components.

PROBLEM	CAUSE	REMEDY
3. The pilot lamp comes on but, with the key in the «START» position, the starter motor does not turn or lacks power (poor starting)	The battery is not supplying sufficient current	Recharge the battery
	Badly earthed battery, or the starter relay or engine not earthed	Check and put right
	Starter relay is faulty	Check that the starter relay is activated
4. The pilot lamp is flashing with the key in the «START» position and the starter motor does not turn	Starting not permitted	After checking that the conditions are met, check all the microswitches and the relative wiring
5. The starter turns but the engine does not start	No fuel flow	Check the leads for the carburettor solenoid valve opening control (if provided) or check the fuel stopcock and filter
	Impaired starter system	Check that the spark plug cap is positioned correctly Check that the spark plug electrodes are clean and have the correct gap
6. The starter continues to turn after engine has started, and does not stop when the key is removed	Mechanical difficulties with the contact breakers of the starter relay	Replace the starter relay
	Starter works erratically for mechanical or electrical reasons taking excessive current and causing binding of relay contacts	Check the starter
7. The starter operates as soon as the key is in the «ON» position, and can be turned off only by removing the key	Fault in the card	Replace the card
	Starter block operating faults	Replace the block
8. The pilot lamp becomes weak after several hours' work and the engine goes off	Insufficient charge	Check that the charging cable has not detached
		Check that there are no current leakages caused by cables with damaged insulation
	Charger fuse blown	Check the recharge circuit Replace fuse (25 A) and check the recharge circuit

IMPORTANT Faulty electronic cards must always be replaced without trying to repair them or replace single components.

PROBLEM	CAUSE	REMEDY
9. The engine stops while in use for reasons not due to the safety devices cutting in	The safety devices have cut in or are faulty	Check the operation of the microswitch operation and the relevant wiring
	Accidental detaching of an electrical wire	Check all wiring
	Starting of engine not permitted	After checking that the conditions are met, check all the microswitches and the relative wiring.
10. The 10 A fuse cuts in	Short circuit or overload on the power side of the card (ignition block, starter relay, headlamps and recharger connector)	Find and replace the defective user
	Short circuit or damage to the electronic card protection (power side)	Try changing the card with one that is known to work. If the problem stops, replace the faulty card
11. The 25 A fuse cuts in	Faults in the battery charging circuit	Replace fuse (25 A) and check the recharge circuit
12. No audible signal for the “grass-catcher full” condition	Malfunctioning or faulty blade switch or microswitch and grass-catcher signalling	Check the switch, the microswitch and wiring. WARNING! - Check that the blade switch stops the engine or prevents it from being started if the acknowledgement conditions are not met
	Malfunctioning or faulty electronic card	Try changing the card with one that is known to work. If the problem stops, replace the faulty card

IMPORTANT Faulty electronic cards must always be replaced without trying to repair them or replace single components.

General informations

Related topics

[7.3](#) Safety microswitches operation check

Map of functional units

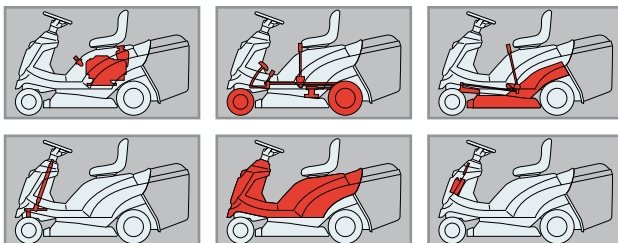

This table shows the various situations in which the safety devices intervene.

A) STARTING («START» position)

The engine DOES NOT start, when:

Operator	-/-	-/-	Absent
Grass-Catcher	-/-	-/-	-/-
Blade	-/-	Engaged	-/-
Drive	Engaged	-/-	-/-
Parking	-/-	-/-	-/-
Indication on the Dashboard			

B) WHILE CUTTING

The engine STOPS start, when:

Operator	Absent	Absent	Absent	-/-	-/-	Seated
Grass-Catcher	-/-	-/-	-/-	Missing	-/-	Fitted
Blade	-/-	Engaged	-/-	Engaged	Engaged	Engaged
Drive	Engaged	-/-	-/-	-/-	-/-	Reverse
Consent Pedal	-/-	-/-	-/-	-/-	-/-	Released
Parking	-/-	-/-	-/-	-/-	Engaged	-/-
Indication on the Dashboard						

-/- Irrelevant condition for the triggering of safety devices

= Pilot lamp on = Pilot lamp flashing

General informations

Related topics

Map of functional units

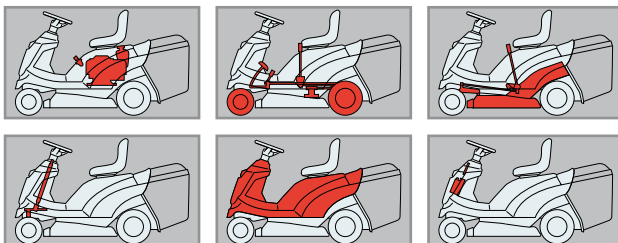

This check is done by disconnecting connector CN1 and using the tester in Ohmmeter mode.

This operation must be performed without the operator aboard, making contact with the ferrules on the contacts of the wiring connector (1) and must give these results:

N° Contacts	Tester reading and condition		
GRASS-CATCHER ATTACHED MICROSWITCH			
10 - 6	∞ (without g.catc.)	O (with g.catcher)	
SEAT MICROSWITCH			
10 - 14	∞ (absent)	O (seated)	
PARKING MICROSWITCH			
10 - 17	O (free)	∞ (engaged)	
BLADE SWITCH			
10 - 16	∞ (engaged)	O (disengaged)	
"IN NEUTRAL" SIGNAL			
10 - 7	∞ (drive)	O (neutral)	
GRASS-CATCHER FULL MICROSWITCH			
13 - Earth	O (full)	∞ (empty)	
REVERSE GEAR MICROSWITCH			
10 - 15	∞ (Pressed)	O (Released)	
REVERSE CONSENT PEDAL MICROSWITCH			
8 - 9	O (Pressed)	∞ (Released)	
STARTER UNIT			
+ Battery - 11	∞ (OFF)	O (ON)	O (START)
+ Battery - 12	∞ (OFF)	∞ (ON)	O (START)

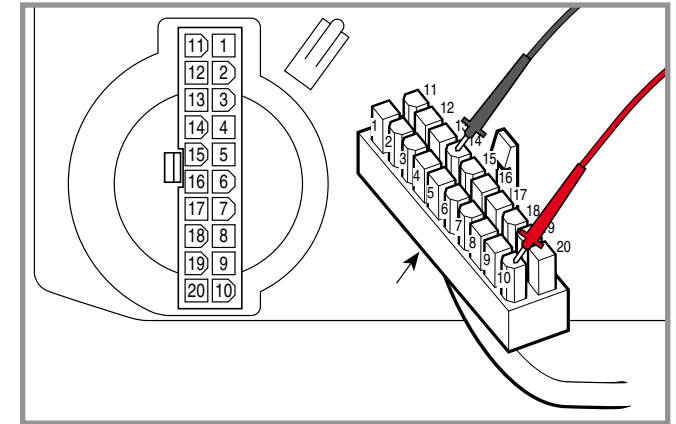

ENGINE STOP

This operation must be done by keeping the connector (2) attached and should give this result:

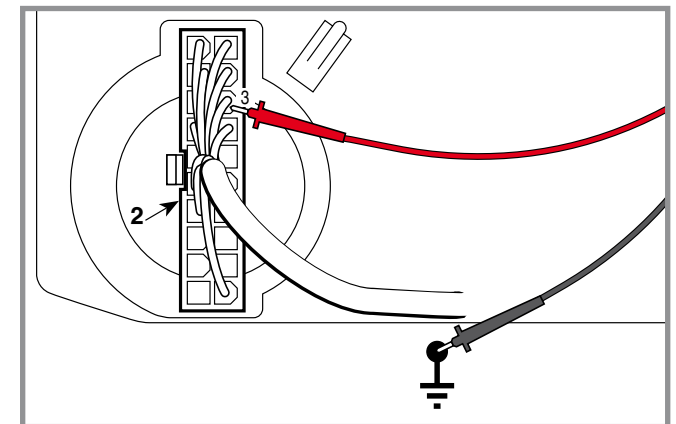

N° Contacts	Tester reading and condition
3 - Earth	O (Always)

TERMINAL BOARD SUPPLY CHECK

General informations

Related topics

Map of functional units

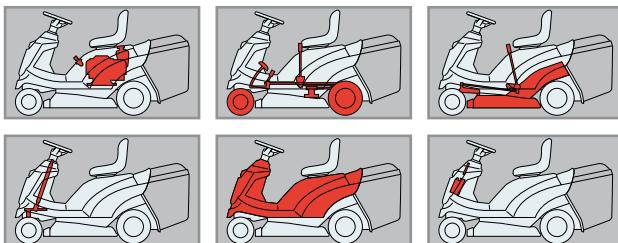

This check is made with the tester operating as a Voltmeter (Volts DC 0 ÷ 20), with the black ferrule on terminal 1 and the red one on terminal 11 of the connector (1) of the wiring.

- The key in the «ON» position

The reading shows the battery voltage, which should never go below 11 Volts.

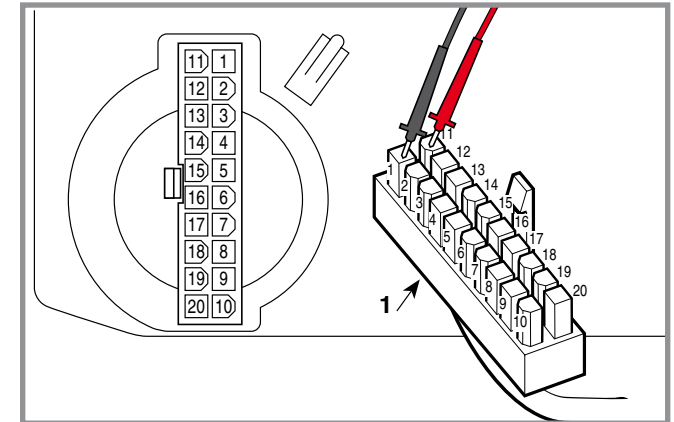

General informations

Related topics

Map of functional units

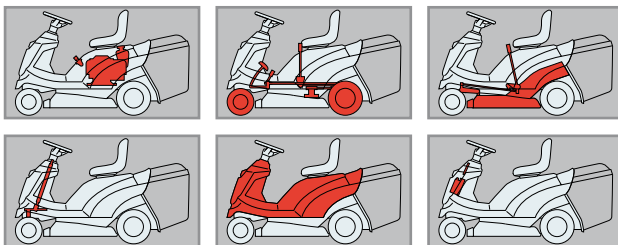

A) Starter relay operation check

! WARNING! Remove the cap of the sparking plug (or plugs), since the safety systems that normally prevent accidental starting of the engine are cut out when the checking procedure is carried out.

To do this requires:

- operator seated,
- blade disengaged,
- the key in the «ON» position.

Disconnect the connector (1).

In making a bridge between the terminals 11 and 4 of the wiring connector (1), the click of the relay bobbin should be heard and the starter motor should come into action.

- ▶ **except Honda engines:**
- If the bobbin clicks but the starter does not start, make a bridge (2) with a large section cable (5 mm²) between the power contacts of the relay.
- If the starter comes into operation, look for the fault within the relay or replace it. Otherwise, check the starter together with its wiring.

B) Carburettor solenoid valve operation check (where fitted)

To make this test it is necessary to have:

- The key in the «OFF» position
- Connector (3) connected to the card,

When the key is set to «ON», a click must be heard from the carburettor solenoid valve coil.

Otherwise, check wiring and, if the problem persists, replace the solenoid valve.

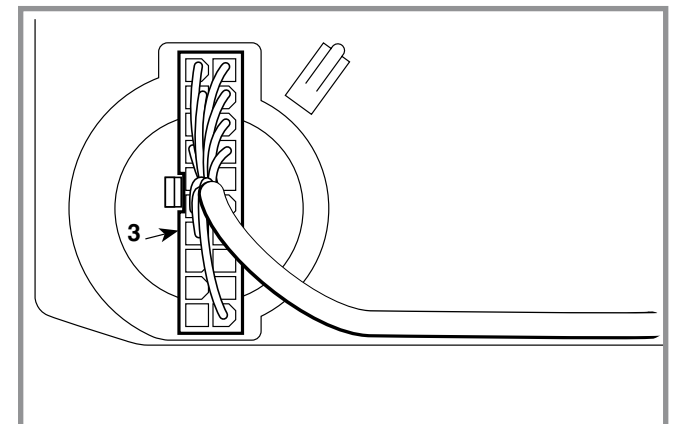
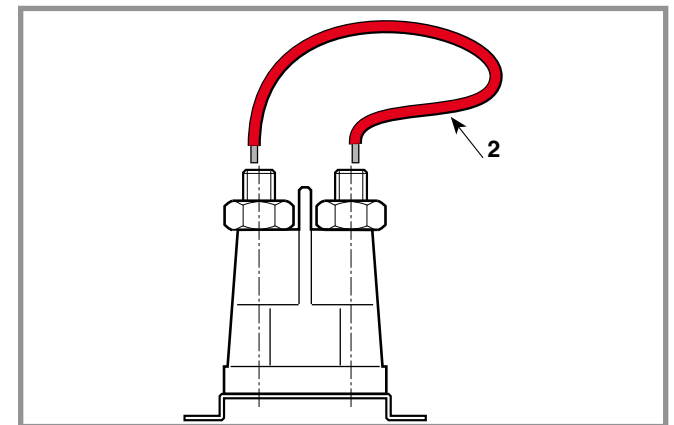
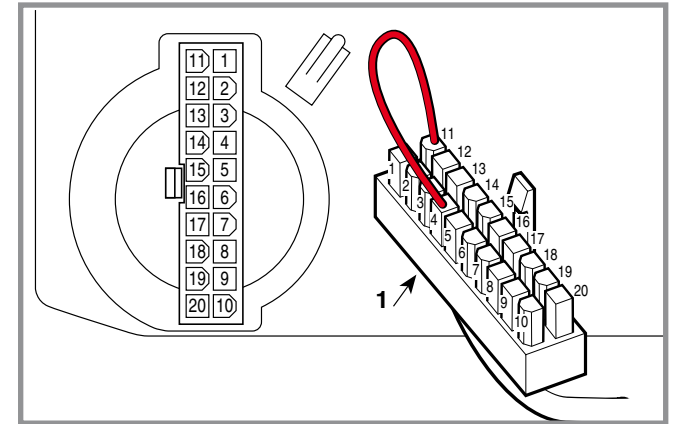

ELECTRONIC CARD OPERATION CHECK

CHAPTER	REVISION	FROM ...	PAGE
7.6	0	2018	1 of 1

General informations:

Related topics:

Map of functional units

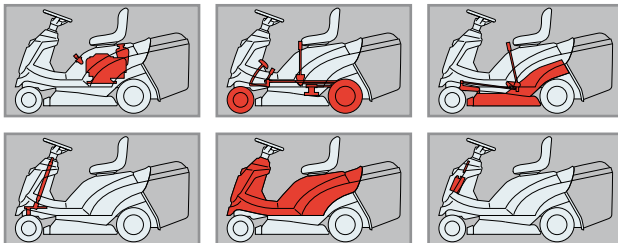

To make this tests it is necessary to have:

- The key in the «ON» position
- Connector (1) connected to the card.

In this situation the pilot lamp should come on.

A) Card supply

This check is done with the tester in Voltmeter function (Volt DC 0 ÷ 20), with the black ferrule on terminal 1 and the red ferrule on terminal 11 of the wiring connector (1).

The reading on the tester shows the battery's voltage.

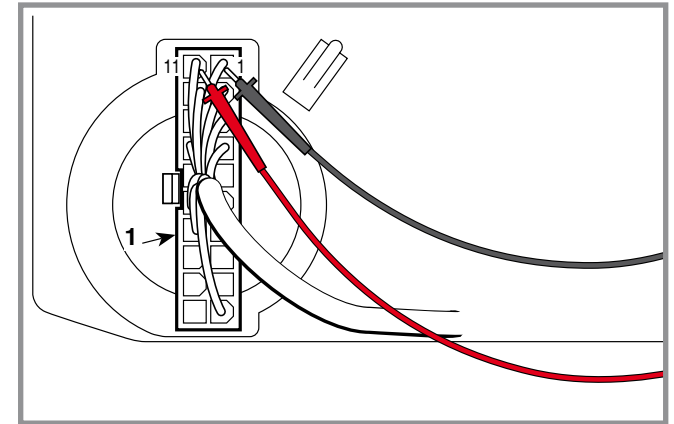

B) Safety and service supply check

This check is done with the tester in Voltmeter function (Volt DC 0 ÷ 20), with the black ferrule to earth and the red ferrule on terminal 10 of the wiring connector (1).

The reading on the tester shows a slightly lower battery voltage value than that produced by the test described in section "A".

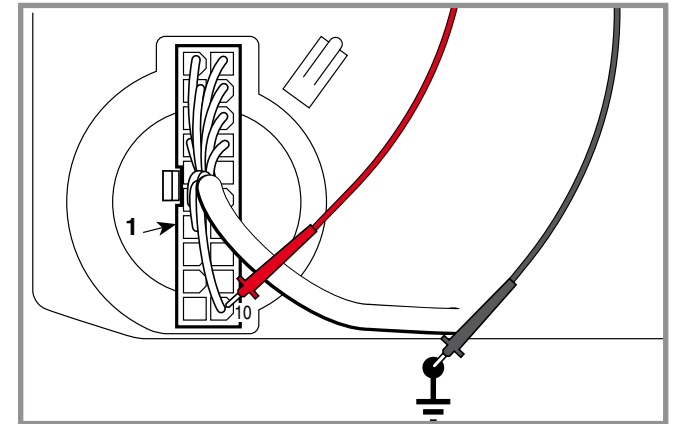

C) Checking the operation of the self-setting protection

By connecting terminal 10 of the connector (1) to the frame's earth, the pilot lamp should go out due to the protection cutting in; eliminating the connection to earth, the pilot lamp should come on again.

NOTE During this test, the self-setting protection reaches very high temperatures (around 160 °C) which are to be considered normal. Similarly, there might be some smoke inside the transparent box which is due to the overheating of the powder inside.

⚠ WARNING! Do not touch this component of the card until it has cooled down.

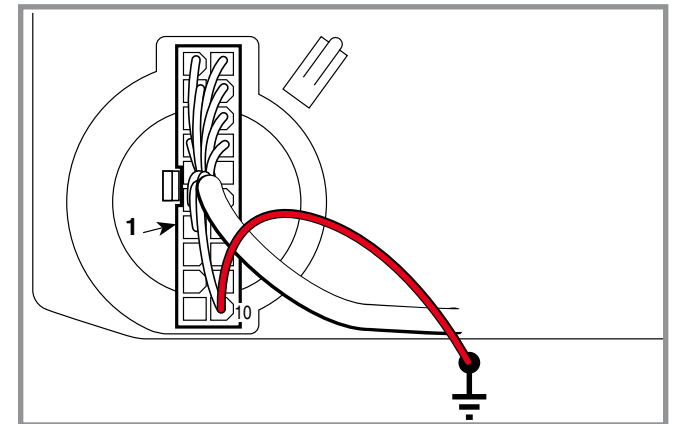

RECHARGE CIRCUIT CHECK

CHAPTER	REVISION	FROM ...	PAGE
7.7	0	2018	1 of 1

General informations

Related topics

Map of functional units

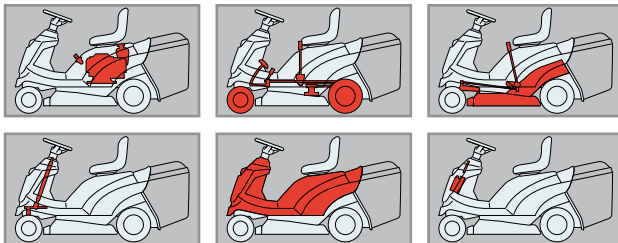

The job of the voltage regulator is to supply a flow of current to the battery at a constant voltage of about 14 -15 Volts, cutting in every time that the output voltage from the generator exceeds this threshold.

A faulty regulator may recharge the battery insufficiently (therefore needing frequent recharging) or, otherwise, may supply overloading that causes the self-resetting protection to cut in.

Before checking the recharge circuit, make sure that:

- all connections are correct;
- the earth connections are firmly connected, especially the earth connection to the regulator;
- the battery is charged and not sulphated;
- the charger fuse is not blown.

A) Checking the lower charging limit

Start the engine and keep running at minimum with the headlights on.

With the voltmeter tester, measure the voltage at the battery terminals. If the value does not rise but tends

to fall, even slowly, it means that the regulator is not charging sufficiently and must be replaced.

If the voltmeter shows no value it means that the charger fuse is blown.

- **only with a Honda engine:**
- check the recharge relay. On moving the key from «OFF» to «ON» and vice versa, the ticking of the relay contacts should be heard; otherwise it should be replaced.

B) Checking the upper charging limit

Start the engine and take it to maximum speed. With the tester in the voltmeter function, measure the voltage at the battery terminals. The amount should slowly rise and settle at 14-15 Volts after about 10-15 minutes.

If this value is exceeded to the extent that the engine stops due to the self-resetting protection cutting in (at approximately 16 Volts) it means that the regulator is charging too much and must be replaced.

General informations

Related topics

Map of functional units

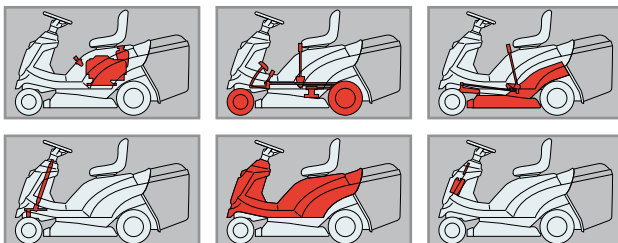

A) General information

In a sealed “dual” battery, the electrolyte for each element is carefully measured out during manufacture and sealed at source, in order to ensure maximum performance during the battery’s entire life.

With a battery of this type, it is not necessary to add water or acid, and the cover must never be opened or removed.

B) Recommendations for correct use

To keep the battery performing at optimum levels and to increase its life, various precautions should be taken:

- always keep the battery fully charged;
- always recharge a flat battery within 1 month, otherwise the elements could be damaged and no longer able to take the charge (sulphated);
- always recharge the battery before and after periods of prolonged inactivity or storage.

IMPORTANT! Only recharge with a constant voltage battery charger. Use of other types of battery charger could damage the battery.

C) Rules for recharging the battery

La ricarica è una operazione particolarmente IMPOR- Recharging is a particularly important operation for the life of the battery and must be carried out according to these instructions:

- do not recharge the battery when its case is broken or damaged;
- carefully read the instructions for using the battery charger and the battery;
- use a suitable battery charger;
- recharge at a room temperature of between +10 and +30 °C;
- check that the battery does not heat to beyond 50 °C while recharging. If it should do so, stop recharging immediately and dispose of the battery since it will be unusable.

With the battery disconnected (and at rest for at least 12 hours) and the tester in voltmeter function, measure the voltage between the terminals. The amount given (open circuit voltage) gives an indication of the operations to be carried out, as per the following table:

Battery voltage with open circuit	Battery state	Operation to be carried out
> 12.6 Volt	Fully charged	None
< 12,4 Volt	Flat	Recharge

Check the battery voltage at least 12-24 hours after recharging.

General informations

Related topics

! **IMPORTANT!** *If the microswitches are to function correctly, it is important to follow the exact assembly positions by referring to the drawings that indicate the various usages of each type.*

A = Free
B = Activated

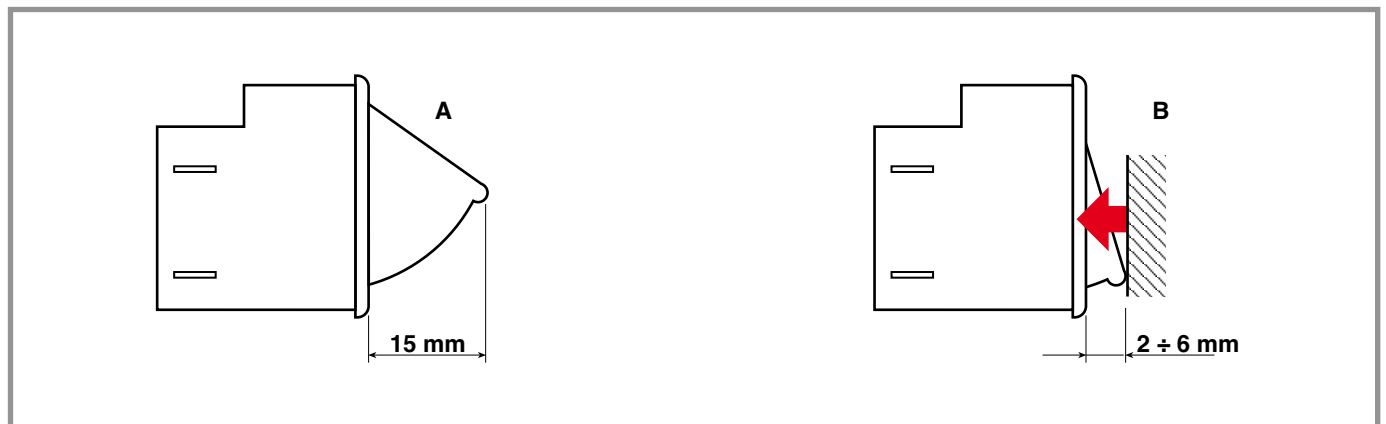
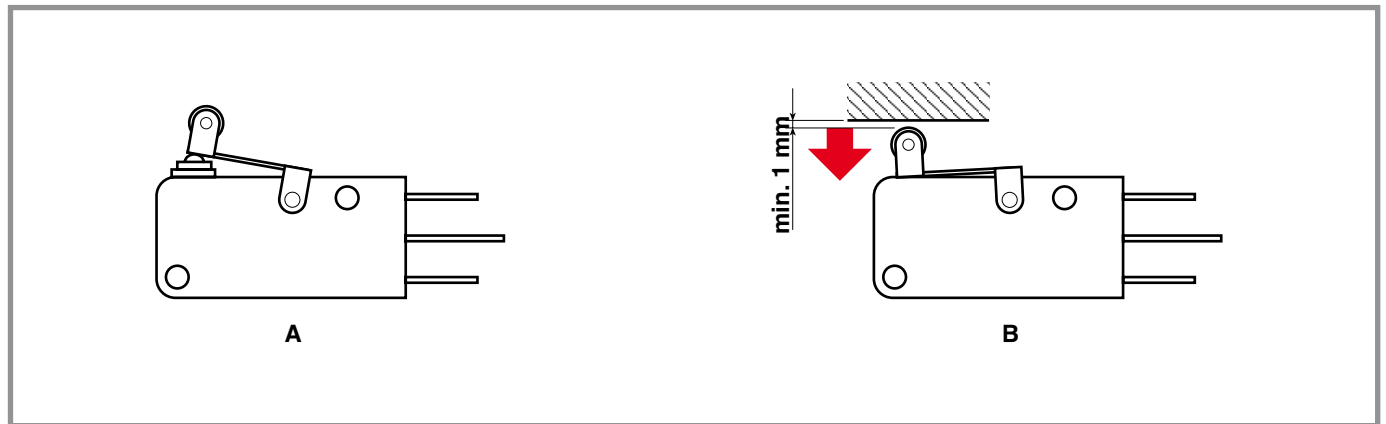

Map of functional units

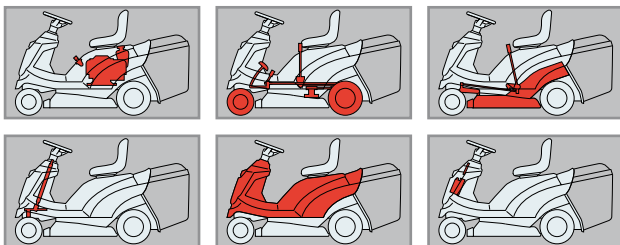

General informations

Related topics

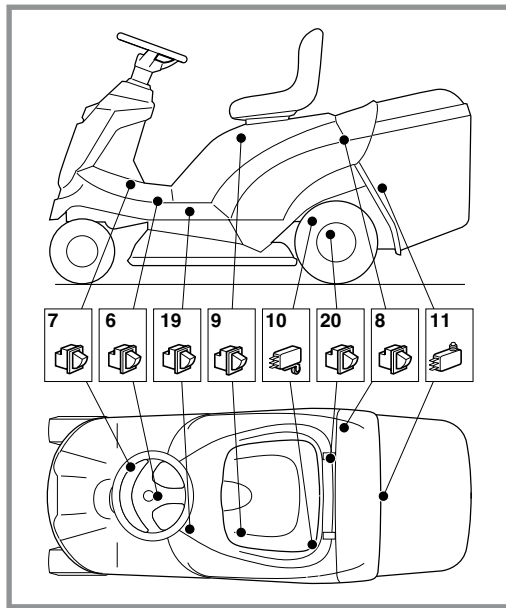

Map of functional units

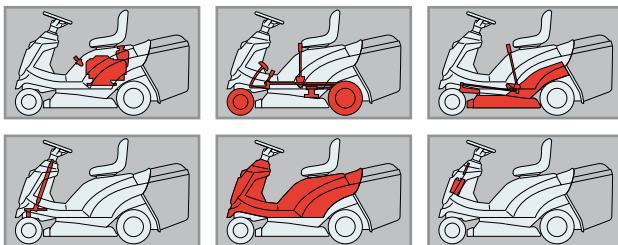

Engines B&S - Stiga

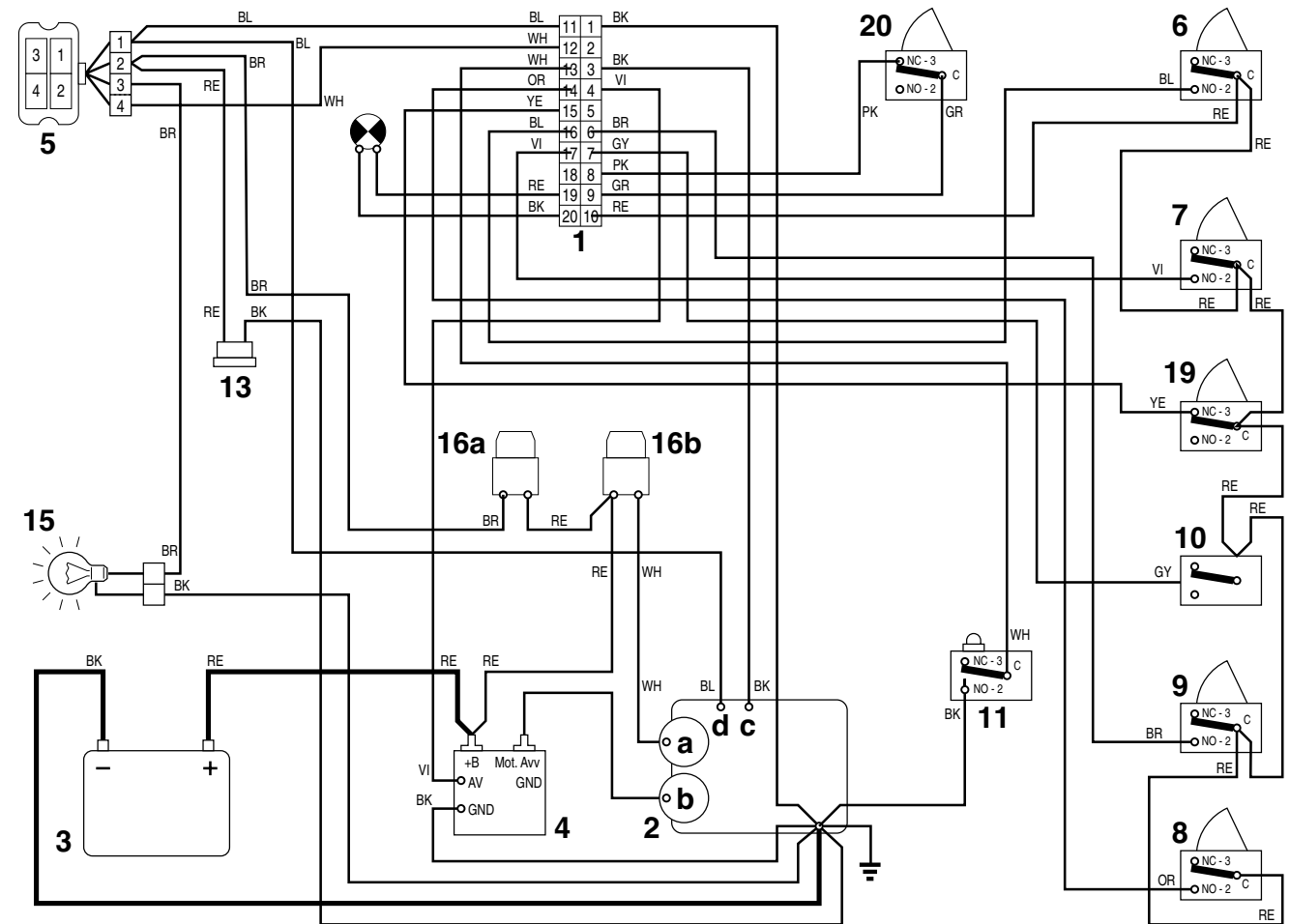

- 1 Electronic card
- 2 Engine
- 2a Generator
- 2b Starter motor
- 2c Engine stop
- 2d Carburattor
- 3 Battery
- 4 Starter relay
- 5 Key ignition switch
- 6 Blades switch
- 7 Brake microswitch
- 8 Grasscatcher microswitch
- 9 Seat microswitch
- 10 Neutral microswitch
- 11 Grasscatcher full microswitch
- 12 Clutch
- 13 Recharge connector
- 15 Headlight
- 16a 10 A fuse
- 16b 25 A fuse
- 19 Reverse consent pedal microswitch
- 20 Reverse gear microswitch

CABLE COLOURS

- BK Black
- BL Blue
- GR Green
- BR Brown
- GY Grey
- OR Orange
- PK Pink
- RE Red
- VI Violet
- WH White

General informations

Related topics

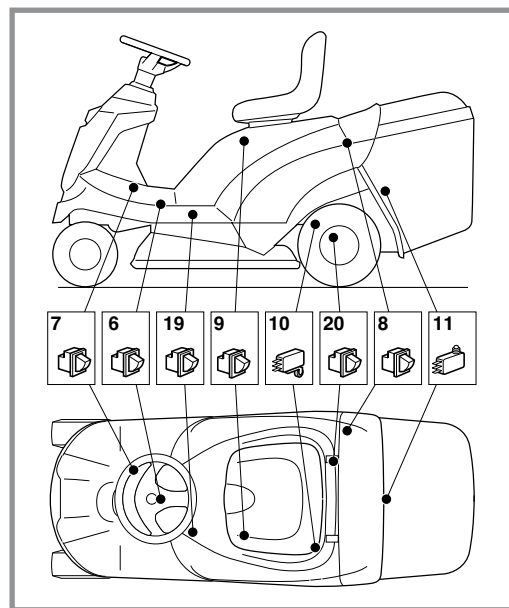

Map of functional units

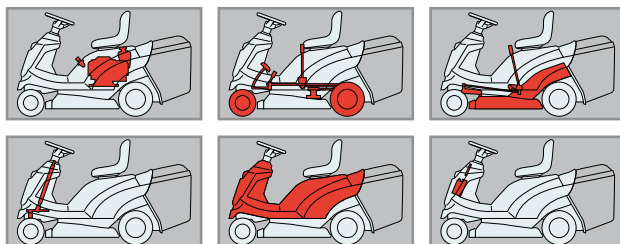

Engines Honda

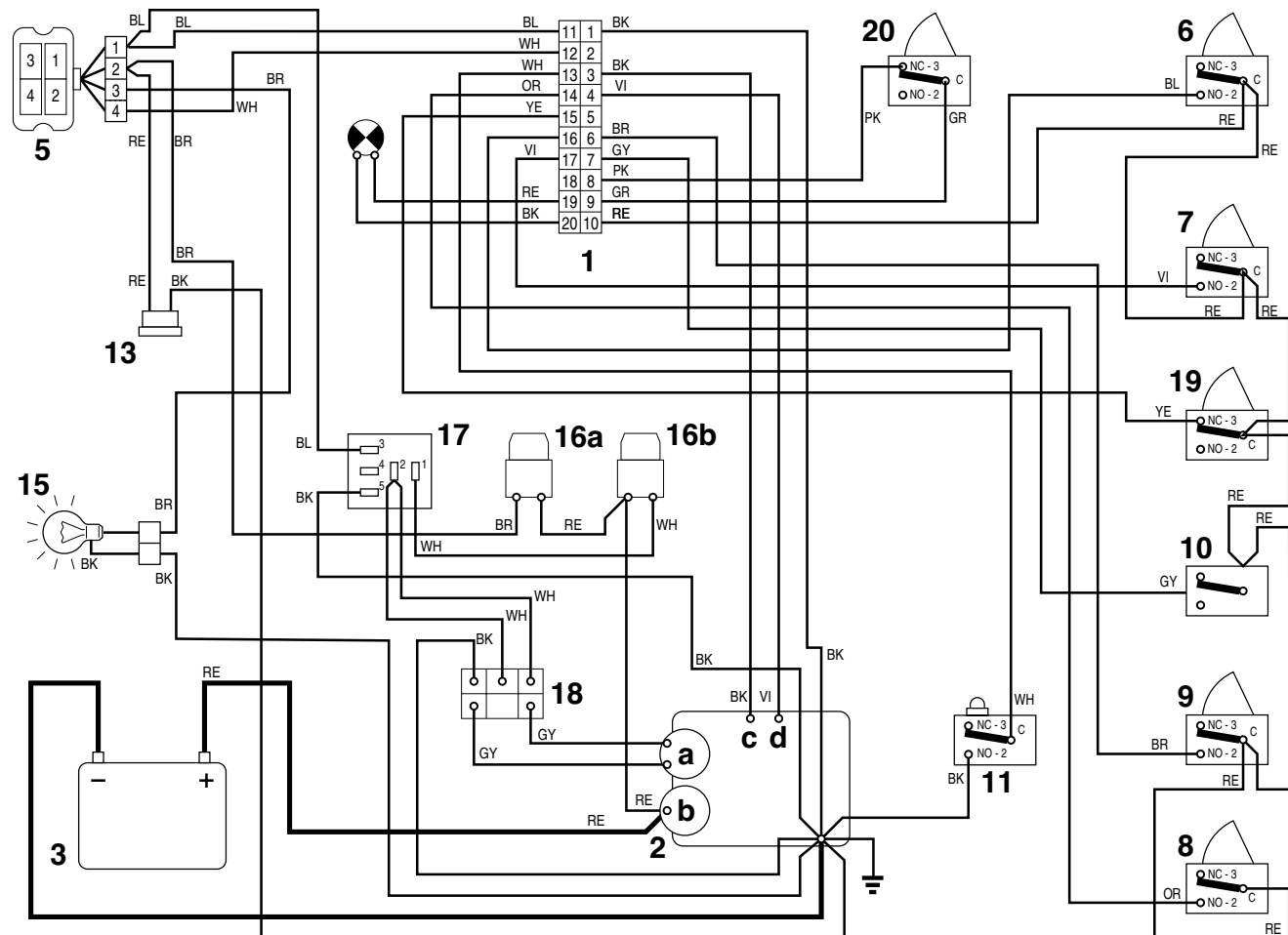

- | | |
|----------------------------|--------------------------------------|
| 1 Electronic card | 10 Neutral microswitch |
| 2 Engine | 11 Grasscatcher full microswitch |
| 2a Generator | 12 Clutch |
| 2b Starter motor | 13 Recharge connector |
| 2c Engine stop | 15 Headlight |
| 2d Carburattor | 16a 10 A fuse |
| 3 Battery | 16b 25 A fuse |
| 5 Key ignition switch | 17 Recharge relay |
| 6 Blades switch | 18 Recharge regulator |
| 7 Brake microswitch | 19 Reverse consent pedal microswitch |
| 8 Grasscatcher microswitch | 20 Reverse gear microswitch |
| 9 Seat microswitch | |

CABLE COLOURS

- | | |
|----|--------|
| BK | Black |
| BL | Blue |
| GR | Green |
| BR | Brown |
| GY | Grey |
| OR | Orange |
| PK | Pink |
| RE | Red |
| VI | Violet |
| WH | White |

General informations

Related topics

 **4.1** Blade engagement adjustment

 **4.3** Brake adjustment

 **4.11** Drive belt adjustment

Map of functional units

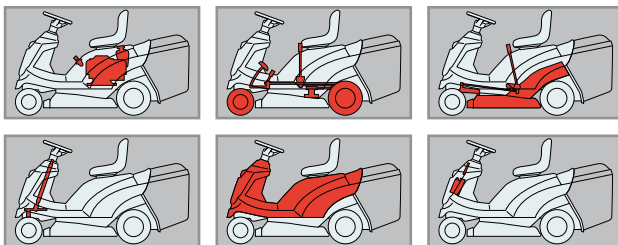

A) Tightening torques

Below are the specified tightening torques for the fixing bolts on the main parts.

- 1 Screws for engine fastening 25 ÷ 30 Nm
- 2 Screw for engine pulley 45 ÷ 50 Nm
- 3 Screws for rear axle brackets 25 ÷ 30 Nm
- 4 Blade pulley screw 25 ÷ 30 Nm
- 5 Nuts for flanged supports 25 ÷ 30 Nm
- 6 Screw for blade 45 ÷ 50 Nm

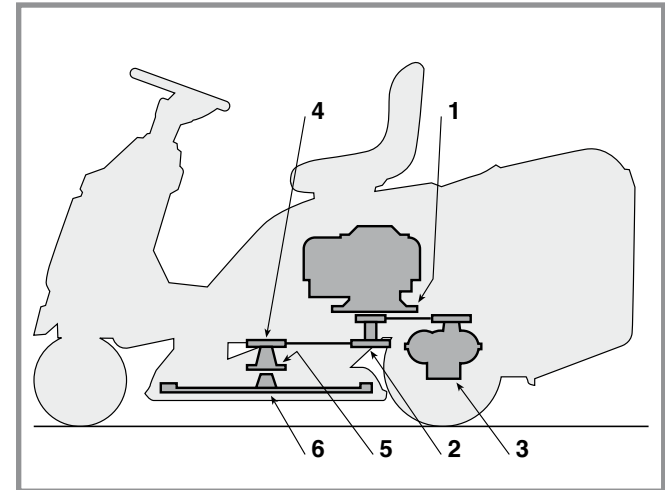

Every section in this manual gives values for all the components involved in each operation.

B) Adjustments

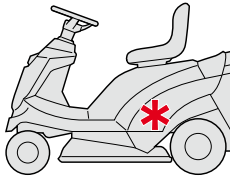
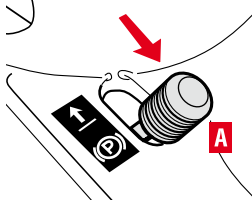
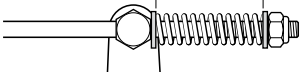
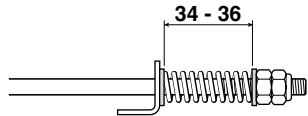
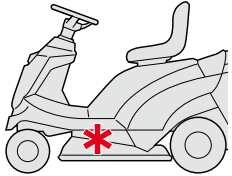
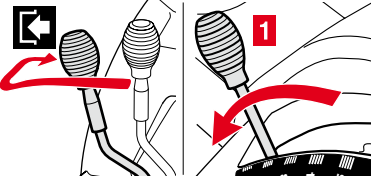
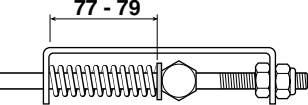
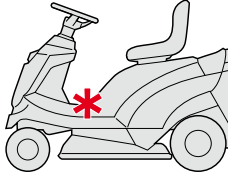
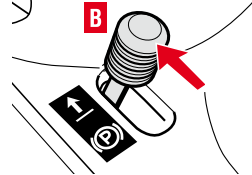
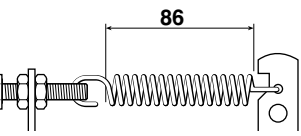
Operation	Position	Position of controls	Adjustment
a) Brake adjustment			<p>Tuff Torq K46T 45 - 47</p>  <p>Hydro Gear T2-BDBE-2X1A-16X1 34 - 36</p> 
b) Blade engagement adjustment			<p>77 - 79</p> 
c) Drive belt adjustment			<p>Peerless MST 205-541 E 86</p> 

General informations:

Related topics

[\[🔧 6.4\]](#) Replacement of the drive belt

[\[🔧 6.5\]](#) Replacement of the blade control belt

Map of functional units

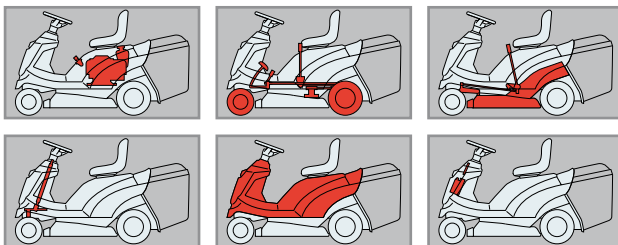

1

➤ *mechanical drive models:*

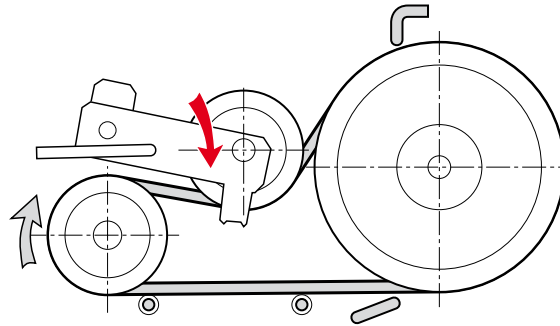

➤ *hydrostatic drive models*

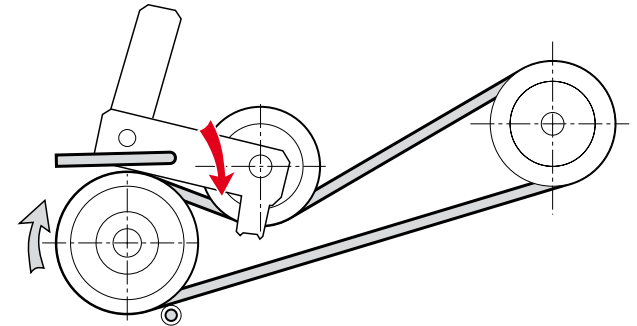

1 Drive belt development

2 Blade control belt development

2

