

STIGA



WORKSHOP MANUAL



IMPORTANT NOTICE

The information contained herein is intended for Service Operations and professionals only, able to competently perform the operations described herein, using the appropriate equipment in order to safeguard se-curity and performance of the machine.

The manufacturer is not liable for damages or injuries arising from operations performed by individuals or inadequate facilities.

- The Manufacture reserves the right to make any improvements to the product of a technical or commercial nature that may be necessary. There maybe, therefore, differences between the various series of machines and that described here, though the basic features and various repair methods will remain the same.
- © by STIGA - No use of the illustrations or duplication, reproduction or translation, even partial, of the texts in this document may be made without explicit authorization.
- All brands, names, logos and trademarks mentioned belong to their respective owners.

MP 84/98 - MP 84/98 Hy - Edition 2018--->2021



GENERAL INFORMATIONS

The purpose of this manual is to assist Service Centres with service, disassemble and repair the versions of the machines:

- mechanical driven (**MP 84/98**);
- hydrostatic driven (**MP 84/98 Hy**).

The manual has left out the simplest and quickest operations that can be handled by a good mechanic, while concentrating more on specific aspects with tips and advice on the best servicing procedures.

Please take time to read through this manual to acquire a basic understanding of the machine, which is necessary for working rationally without making errors or wasting time.

All problems related to the use of the machine are fully covered in the User manual.

STRUCTURE OF THE MANUAL

The manual is divided into sections and chapters. Each page of this manual states the following information:

- A) Machines or series of machines to which the contents of the chapter are applicable.

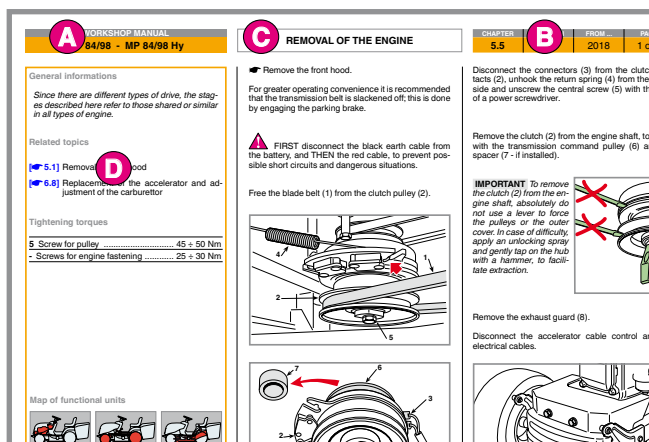

HOW TO USE THE MANUAL

- B) Identification and number of the page based on the following criteria:
- the first field indicates the section and chapter;
 - the second field indicates the revision index;
 - the third field indicates the chapter validity start date, i.e. the year of manufacture of the machine;
 - the fourth field indicates the page number and total number of pages dedicated to the subject.
- C) Chapter title.
- D) General information, references to other chapters in the manual, technical information related to the topic, and buttons with links to the machine operating units map can be found in the left column on each initial page.

SECTIONS OF THE MANUAL

The content of the manual is divided into sections which correspond to the various subjects and the different types of servicing.

1. Rules and procedures for Service Centres

This chapter covers all the main aspects of the relationship between the manufacturer and the service centres.

A close collaboration between the manufacturer and the service centres is conclusive for solving problems in the most effective way as well as maintaining an image of efficiency and reliability. Compliance with these brief and simple guidelines will facilitate this task and prevent general misunderstandings and time-wasting for both the manufacturer and the service centre.

2. General regulations

This chapter covers the main aspects of a servicing procedure and the general rules for guaranteeing a successful service which protects the environment and respects the safety of both the serviceman and the user of the apparatus.

CHAPTER	REVISION	FROM ...	PAGE
i	1	2018	1 of 2

3. Maintenance

This chapter covers the main aspects of a servicing procedure.

A specific chapter is dedicated to a quick troubleshooting guide on the most frequent questions and the chapter references providing information on the interventions required to resolve the same.

4. Adjustments and tuning

This chapter deals with the adjustments to be made to remedy the more frequent performance failures and are usually resolved by quick checks and tunings.

5. Removal of external parts and main assemblies

For doing more difficult jobs, greater accessibility may be required. This can be done by taking the unit concerned off and working at the bench, or by removing the cover or other external parts.

Whether or not this will be useful is at the discretion of the mechanic's experience.

6. Repairs

This chapter deals with all the more complex work connected with the replacement or repair of malfunctioning or worn parts.

The descriptions must follow a logical sequence and can include operations not specifically connected to a particular type of repair.

In this case, careful reading of the entire procedure can help you omit all those operations not connected with the case in hand without, however, overlooking anything that may be necessary.

7. Electrical system

This chapter deals with the problems and checks connected with the electrical system.

All work can be done using a tester without having to use special equipment.

The electrical diagrams can be useful to you for

understanding how the system functions and to facilitate the pinpointing of any problems.

8. Technical specifications

This chapter summarises all the main information regarding the machine.

FUNCTIONAL UNITS MAP

The map is a search tool that provides instant access to all information concerning machine operational unit or element. Identification is simplified by the use of icons resembling the various units, each of which is linked to a table of contents that lists all related topics.

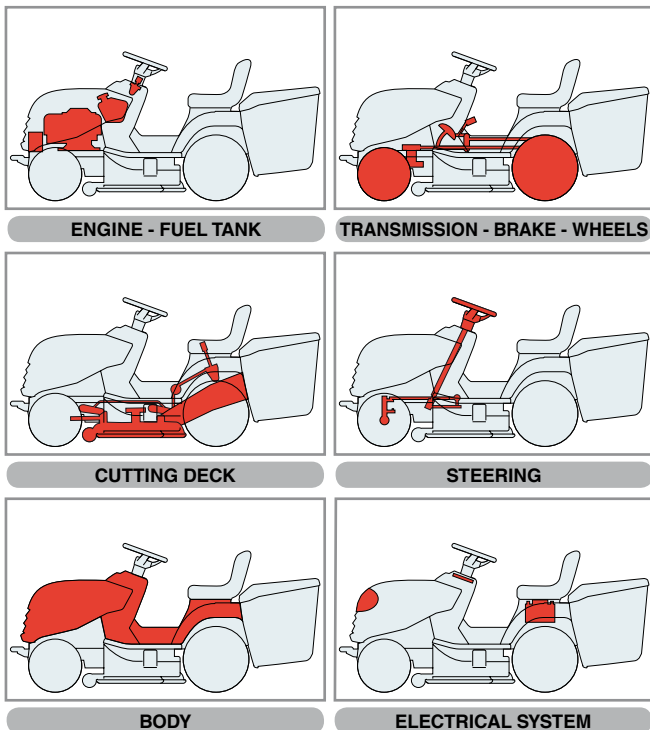

SYMBOLS

In the manual some symbols are present. They are used to draw the attention of the operator, reminding him to perform the interventions with the necessary attention and caution.

- Indicates operations that should be carried out with utmost care to avoid impairing the functionality and safety of the machine.
- Indicates operations that should be carried out with utmost care to avoid injury to operators.
- Highlights all those operations that require different working methods depending on the type of machine, subsequent modifications and the accessories fitted.
- Indicates cross-reference to other parts of the manual, followed by the number of the relevant chapter, paragraph or sub-paragraph.

TERMINOLOGY AND ABBREVIATIONS

Some paragraphs are preceded by a definition that highlights their importance:

NOTE General reference for the correct maintenance execution and methods..

IMPORTANT Specific procedures or information necessary to avoid damage to the machine or equipment.

WARNING! Non-observance will result in the risk of injury to oneself or others.

DANGER! Non-observance will result in the risk of serious injury or death to oneself or others.

Whenever reference is made to a position on the machine “front”, “back”, “left” or “right” side, this refers to the positions of the seated operator.

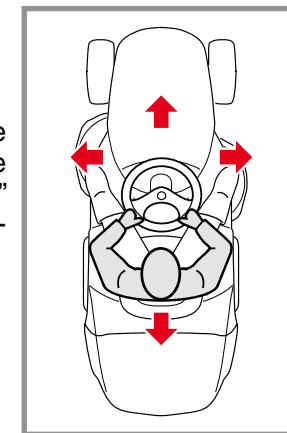

The following abbreviations are used in this manual

- | | |
|-----------|----------------------------|
| Dx / Sx | = Right / LeftV |
| Min / Max | = Minimum / Maximum |
| Chap. | = Chapter |
| PTO | = Power Take Off |
| HST | = Hydrostatic Transmission |

General informations

Different fittings are foreseen for this machine which can imply the use of different engines within the same.

This manual only describes the operations relating to the application of the machine engine; reference to the engine's Manufacturer's Manual is recommended for information regarding servicing, disassembly and replacement of components.

Related topics

[👉 1.1] Identification of components

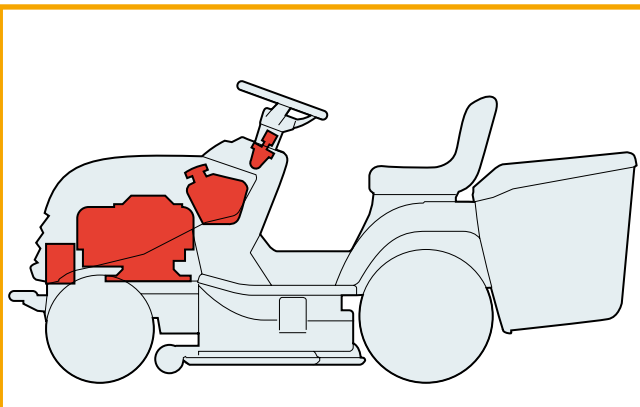

RELATED TOPICS:

Adjustments and tuning

Removal of external parts and main assemblies

- Removal of front hood [👉 5.1]
- Removal of the engine..... [👉 5.5]

Repairs

- Replacement of the accelerator and adjustment of the carburettor [👉 6.8]

General informations

The use of outsourced third-party mechanic or hydrostatic drive units is foreseen on this machine.

This manual only describes the operations relating to the application of the machine units; reference to the drive unit's Manufacturer's Manual is recommended for information regarding servicing, disassembly and replacement of components.

Related topics

[👉 1.1] Identification of components

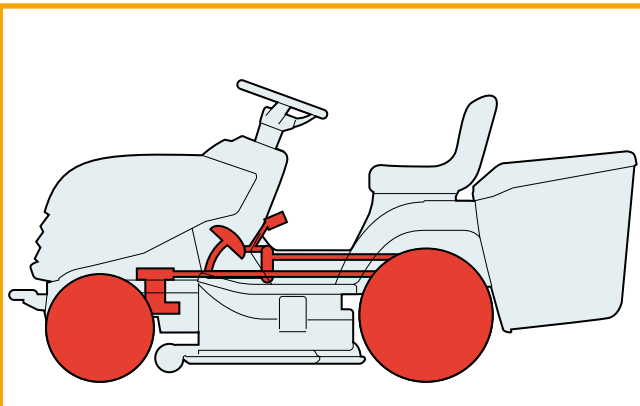

RELATED TOPICS:

Adjustments and tuning

- Brake adjustment [👉 4.2]
- Drive belt adjustment [👉 4.3]
- Drive pedal adjustment (➤ MP 84/98 Hy) [👉 4.4]

Removal of external parts and main assemblies

- Removal of the rear axle (➤ Peerless MST 205-535 E) [👉 5.6]
- Removal of the rear axle (➤ Hydro-Gear T2-ADBF-2X3C-1RX1).... [👉 5.6a]

Repairs

- Replacement of tyres and wheels [👉 6.1]
- Replacement of front wheel bearings [👉 6.2]
- Replacement of the drive belt [👉 6.4]
- Replacement of the small wheels for the drive belt [👉 6.5]
- Replacement of the brake pads and disc (➤ MP 84/98) [👉 6.10]

General informations

The terms "Cutting deck" or "Equipment" refer to the cutting-means assembly, connected to the machine PTO by means of a belt.

Related topics

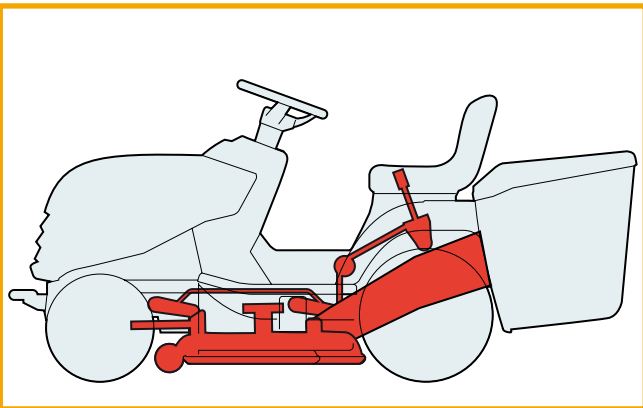

RELATED TOPICS:

Adjustments and tuning

- Adjusting the engagement and checking the blade brake [👉 4.1]
- Aligning the cutting deck [👉 4.5]
- Checking blades alignment [👉 4.8]
- Removing, sharpening and balancing the blades [👉 4.9]

Removal of external parts and main assemblies

- Removal of the side guards (if provided) [👉 5.2]
- Removal of the cutting deck [👉 5.7]
- Removal of the ejection conveyor [👉 5.8]

Repairs

- Replacement of the blades control belt [👉 6.6]
- Replacement of the supports and shafts of the blades [👉 6.7]
- Replacement of the lifting cable [👉 6.9]

General informations

Related topics

RELATED TOPICS:

Adjustments and tuning

- Adjusting the steering play [👉 4.6]
- Steering geometry adjustment [👉 4.7]

Removal of external parts and main assemblies

Repairs

- Dismantling of the steering components [👉 6.3]

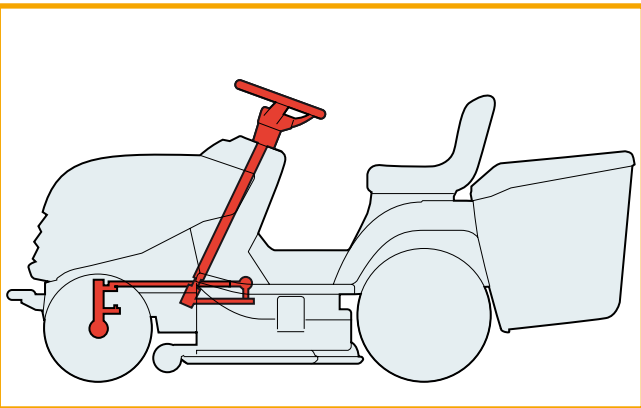

General informations

*Different outfittings are foreseen for this machine which can imply the use of different bodywork designs.
The operations described herein are applicable to all versions, except for instructions provided for each specific outfitting.*

Related topics

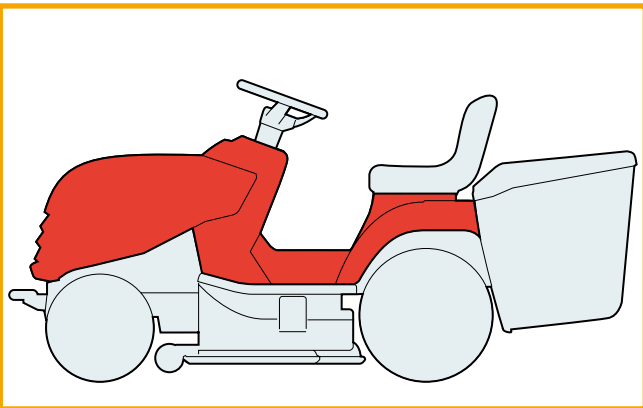

RELATED TOPICS:

Adjustments and tuning

Removal of external parts and main assemblies

- Removal of front hood [👉 5.1]
- Removal of the wheel cover [👉 5.3]
- Removal of the dashboard and front cover [👉 5.4]

Repairs

General informations

Related topics

RELATED TOPICS:

Information and Verifications

Troubleshooting of the electrical system [👉 7.1]
 Cutting in of the safety devices [👉 7.2]
 Safety microswitches operation check [👉 7.3]
 Terminal board supply check [👉 7.4]
 Electromagnetic clutch operation check [👉 7.5]
 Starter relay operation check [👉 7.6]
 Electronic card operation check [👉 7.7]
 Recharge circuit check [👉 7.8]
 Maintenance of the sealed battery [👉 7.9]
 Fitting safety microswitches [👉 7.10]
 Electrical diagrams [👉 7.11]

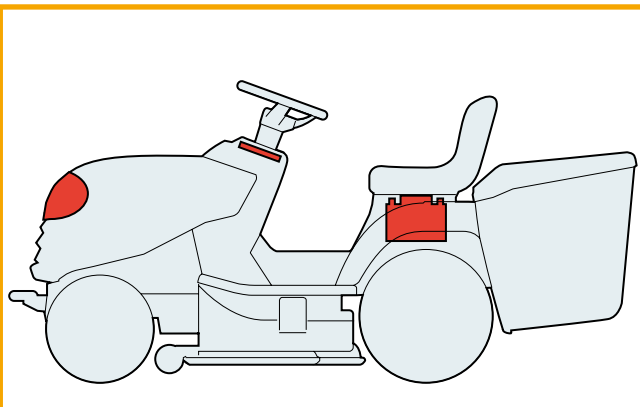

General informations

This chapter covers all the main aspects of the relationship between the Manufacturer and the Service Centres.

A close collaboration between the Manufacturer and the Service Centres is conclusive for solving problems in the most effective way as well as maintaining an image of efficiency and reliability. Compliance with these brief and simple guidelines will facilitate this task and prevent general misunderstandings and time-wasting for both the manufacturer and the service centre.

Related topics

Map of functional units

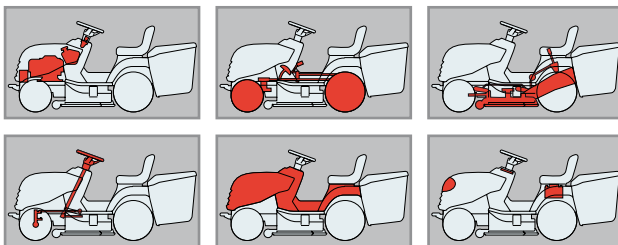

A) Identification

1) Machine

Each machine has a label attached (1) under the driver's seat which shows the technical specifications, the model and the serial number..

The model and serial number must be shown on each repair sheet when requests are made under guarantee, and are indispensable for spare part orders.

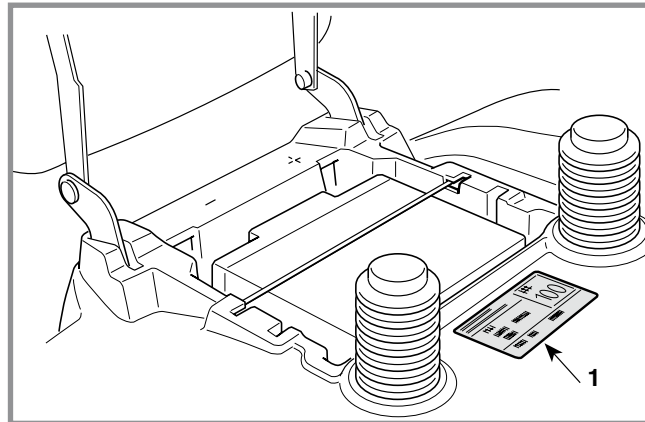

2) Transmission

The transmission unit (both mechanical and hydrostatic) is made up of an engine block including the rear axle. This unit is made by another manufacturer to our precise technical specifications which differentiate it from similar items by this same Manufacturer.

The serial number on the label (2) clearly identifies the product and its specifications. This

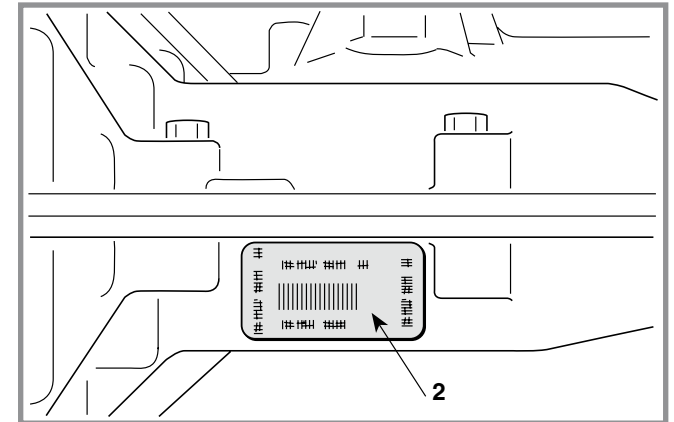

number must always be quoted when requesting spare parts or any information from the Manufacturer.

3) Engine

The engine is made to precise technical specifications which differentiate it from similar items by this same Manufacturer.

The serial number on the label clearly identifies the product and its specifications. This number must always be quoted when requesting spare parts or any information from the Manufacturer.

B) Guarantee validity

The guarantee is supplied under the terms and the limits of the contractual relations in being. As far as the engine and the transmission unit are concerned, the conditions given by their respective manufacturers apply.

C) Service repairs after guarantee period

The Service Centre has to make out a report containing the machine's serial number, a summary of the problem, the repairs carried out and any spare parts used for each repair done on the machine.

A copy of this report must be retained to be made available to the Manufacturer together with the parts in case of any subsequent disputes with Customers.

D) Fault notification

The Manufacturer welcomes any notifications of faults that recur with particular frequency. It gives the opportunity for a careful inspection of the problem and the implementation of corrective action at production level.

Similarly, the Manufacturer will notify of any faults discovered on the machines produced, with recommendations for the most suitable procedures for their remedy.

E) Spare parts request

When requesting spare parts, the code number must be given, referring to the exploded charts for the year of manufacture, shown on the identification label.

General informations

This chapter covers the main aspects of a servicing procedure and the general rules for guaranteeing a successful service which respects the safety of the machine.

Related topics

 **2.2** Tools

 **7.3** Safety microswitches operation check

Map of functional units

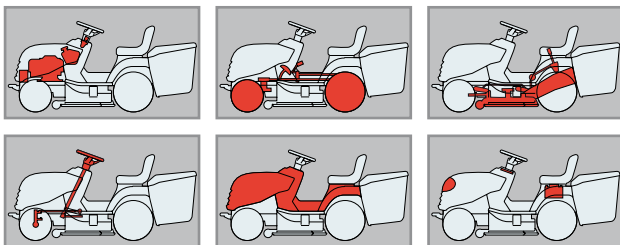

SAFETY REGULATIONS

A) Qualification of operators

All maintenance, disassembly and repairs must be carried out by expert mechanics who are familiar with all the accident prevention and safety regulations after reading through the procedures in this manual.

B) Safety measures

All the machines are manufactured in accordance with the strict European safety regulations in force.

To maintain these levels of safety in the longer term, the Service Centres should work to this end by making appropriate checks every time there is the chance to do so.

Particularly, every time there is work done on the machine the Service Centre should:

1) check:

- that safety microswitches are working correctly;
- that the casings and protection covers have not been removed;
- that the labels with instructions or provisions have not been removed or have become illegible (these form an integral part of the safety system).

2) they should also:

- restore to proper working order any safety devices which have been manipulated or removed;
- reattach inefficient, damaged or missing casings and protection covers;
- replace illegible labels;

CHAPTER	REVISION	FROM ...	PAGE
2.1	1	2018	1 of 2

- not endorse any repair or modification on the machine or the engine which results in a change in performance or use that is incorrect or different from the purpose for which it was designed and approved;
- warn the Customer that the failure to comply with the above points results in the automatic annulment of the Guarantee and the Manufacturer declines all responsibility, as also shown in the Instruction Booklet.

C) Precautions during servicing

The operations described in this manual do not entail particularly hazardous situations besides the normal hazard related to mechanical operations and that can be avoided by taking the necessary care and attention normally required for this type of work.

As well as following the usual accident prevention regulations that apply to most repair shops, we recommend you:

- taking out the ignition key before beginning any repair work.
- protect hands with suitable working gloves, especially when working near the cutting unit;
- check that you do not cause accidental petrol leaks or other losses;
- do not smoke when working on the tank or when handling petrol;
- do not inhale oil or petrol fumes;
- clean up all traces of spilt petrol immediately;
- test the engine in a well-ventilated environment or where there are adequate exhaust fume extraction systems;
- do not pollute the environment with oil, petrol or other waste and dispose of all waste in accordance with the laws in force;

- ensure that other persons cannot accidentally carry out actions that may physically endanger those working on the machine.

D) Necessary equipment

All the operations can be carried out with the tools normally used in a good garage.

Some operations require special equipment and tools.

TOOLS

General informations

This chapter covers the main aspects of a servicing procedure and the general rules for guaranteeing a successful service which respects the safety of the machine.

Related topics

Map of functional units

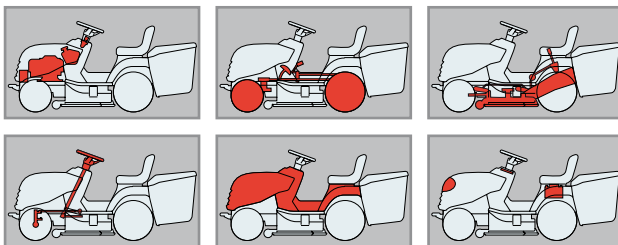

All work can be carried out using the tools normally available from a good workshop. However, it is advisable to have a set of special tools.

These tools are to be used whenever is given in the text.

1. Blocks H = 26 mm for adjusting the cutting deck
2. Blocks H = 32 mm for adjusting the cutting deck
3. Bush for assembly of blades bearings
4. Stopper for assembly of wheel bearings
5. Pulley extractor

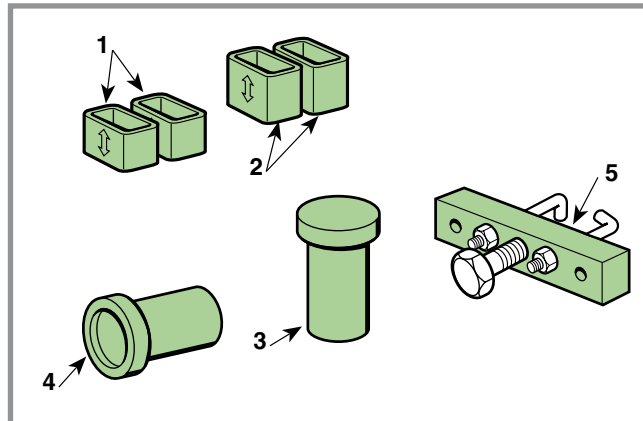

General informations

This chapter covers the main aspects of a servicing procedure and the general rules for guaranteeing a successful service which respects the safety of the machine.

Related topics

Map of functional units

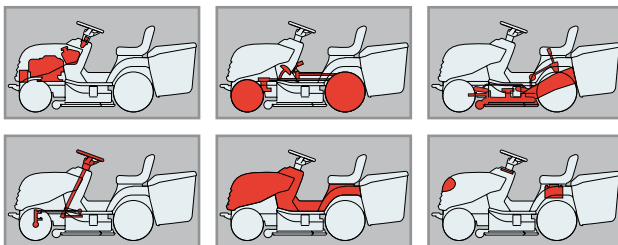

! DANGER! *The machine must never be lifted using a hoist or other lifting equipment which uses cables.*

A) Front

Once the parking brake has been engaged, the machine can be lifted using a jack which pushes on the underside of the frame, placing a wood block (1) between the base of the jack and the frame and checking to see that the free movement of the front spring equaliser has not been obstructed.

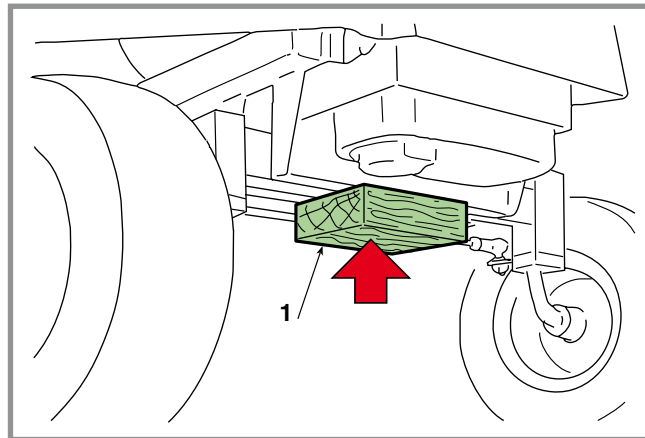

B) Rear

Position two suitably sized wedges (3) in front of the front wheels to prevent all uncontrolled movement of the machine.

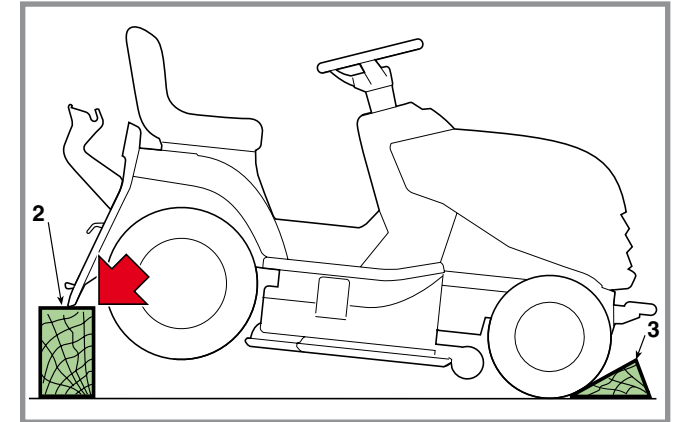

Position a jack under the transmission unit and lift it enough to place two suitable blocks (2) beneath the lower edge of the rear plate.

Release the jack and make sure the machine is stable before starting any work.

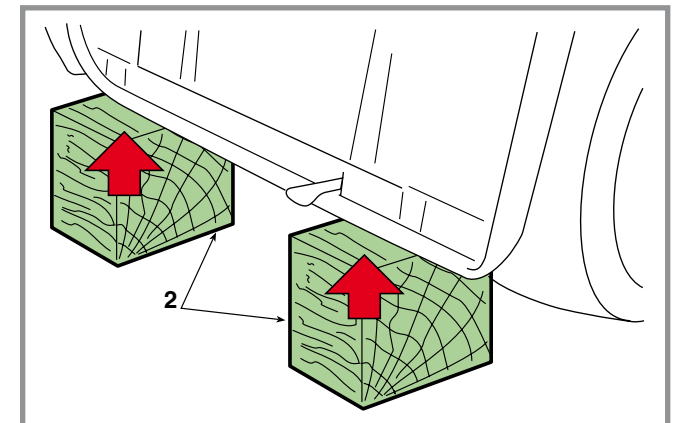

C) Vertical positioning

! WARNING! *Two people will be needed for this operation. When lifting and tipping backwards, only solid parts should be gripped (steering wheel, frame, rear plate, etc.) and NEVER parts of the bodywork in plastic.*

The tank must be checked before putting the machine in a vertical position to make sure that there is no more than 2 litres of fuel inside.

To assure full stability, the machine must only be rested on the points shown, inserting two blocks (1) of about 150 mm under the lower edge of the plate and taking care not to damage the parts in plastic and the grass-catcher mounts (2).

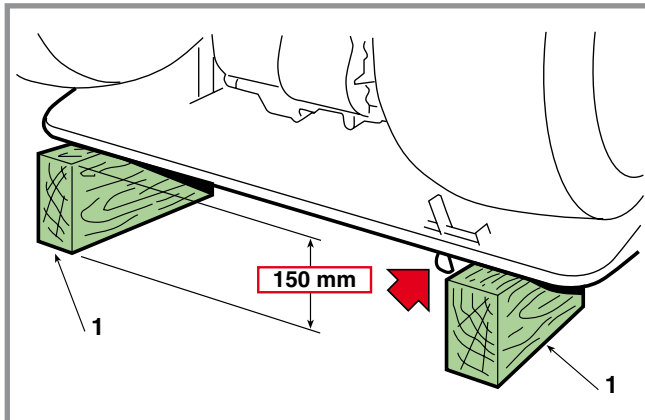

! WARNING! *Before carrying out any type of work make sure that the machine is completely stable, and avoid operations that could cause it to fall over.*

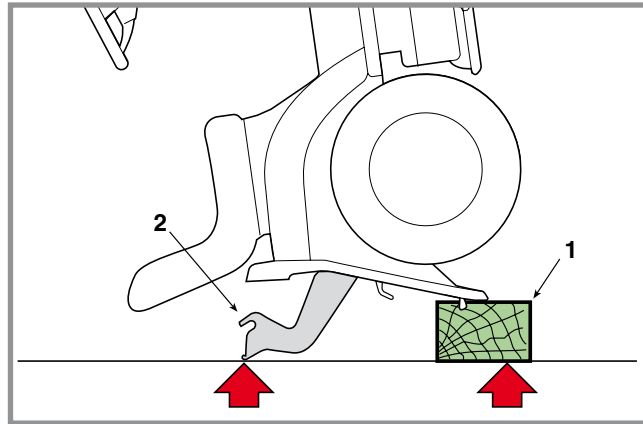

! WARNING! *Be just as careful when putting the machine back on a flat surface; two people are needed for this operation.*

General informations

This chapter covers the main aspects of a servicing procedure and the general rules for guaranteeing a successful service which respects the safety of the machine.

Related topics

Map of functional units

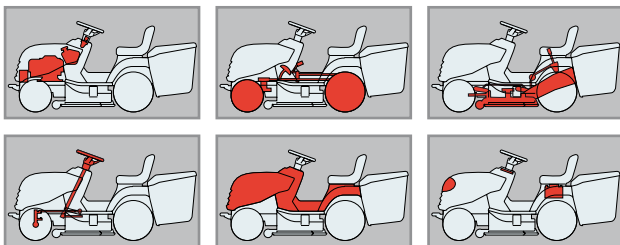

A) Fitting snap rings

One side of the “Benzing” snap rings (1) has a rounded edge and the other a sharp edge.

For maximum grip the rounded part needs to be facing towards the element to be held (2), with the sharp edges on the outside.

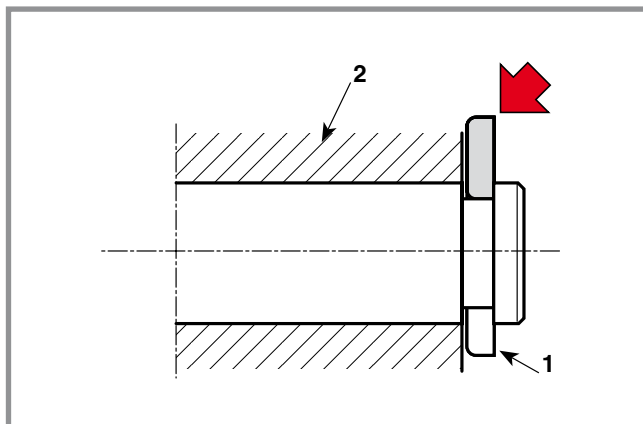
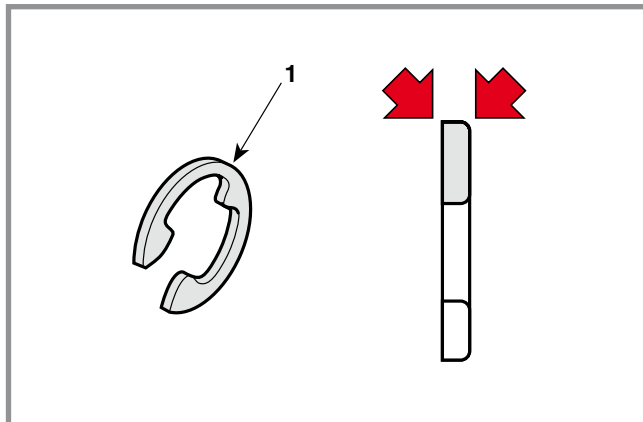

B) Joint pivot pins

There are a large number of pivot pins, usually connected to rods, that need to be able to move in various directions.

A typical situation has the pin (3) fixed by a self-locking nut (4) with two anti-friction washers (5) in between the pin (3) and the support element, and between this and the nut (4).

Since these are joints, the nut must never be tightened completely but only so much that it can ensure the free rotational movement of the pin on its axis without, however, creating excessive free play which could result in the parts concerned becoming misaligned and failing to work correctly.

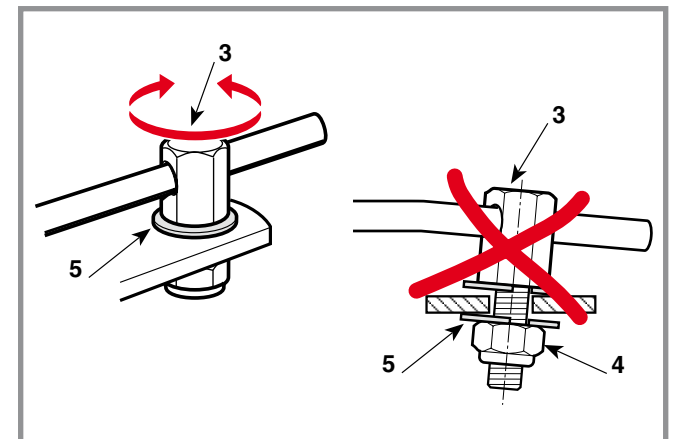
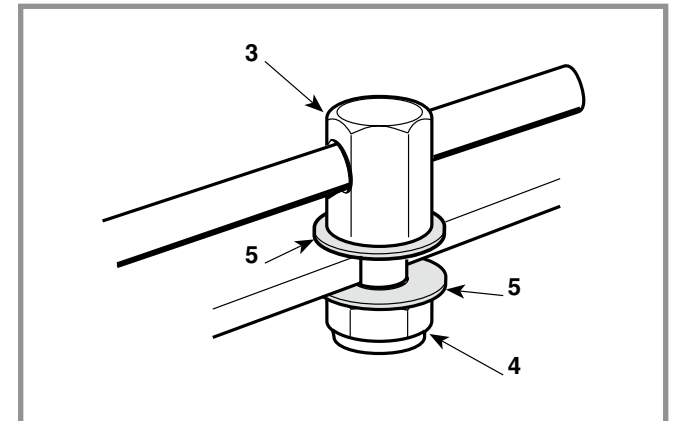

C) Crown fasteners

Some pin ends (6) are secured by crown fasteners (7). During dismantling, these fasteners are always damaged and lose their hold, so they should never be reused.

On assembly, make sure it is inserted in the right direction and push the fastener (7) onto the pin using a pipe or socket spanner (8) with the right diameter, so that it can be fitted without deforming the fastener "crown".

IMPORTANT A deformed fastener should always be replaced.

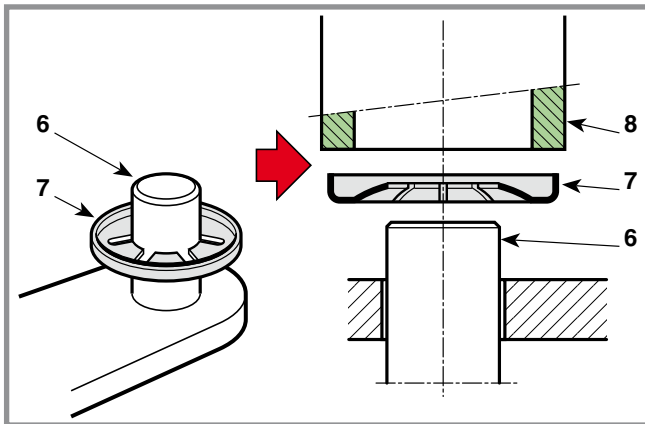

General informations

In questo capitolo vengono trattati i criteri di intervento per la manutenzione ordinaria.

Related topics

Map of functional units

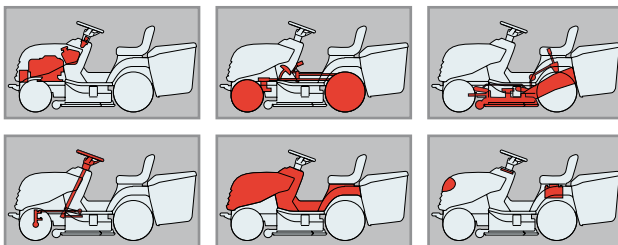

The Instruction Handbook has a number of operations to be carried out by the Customer for a minimum of basic maintenance, and other operations not always within his capacity.

For this reason the Service Centre should undertake to keep the machine in perfect working order in two ways:

- A) Tuning the machine whenever possible.
- B) Proposing a regular maintenance programme to the Customer to be carried out at prearranged intervals (for example, at the end of the summer or prior to a long period of inactivity).

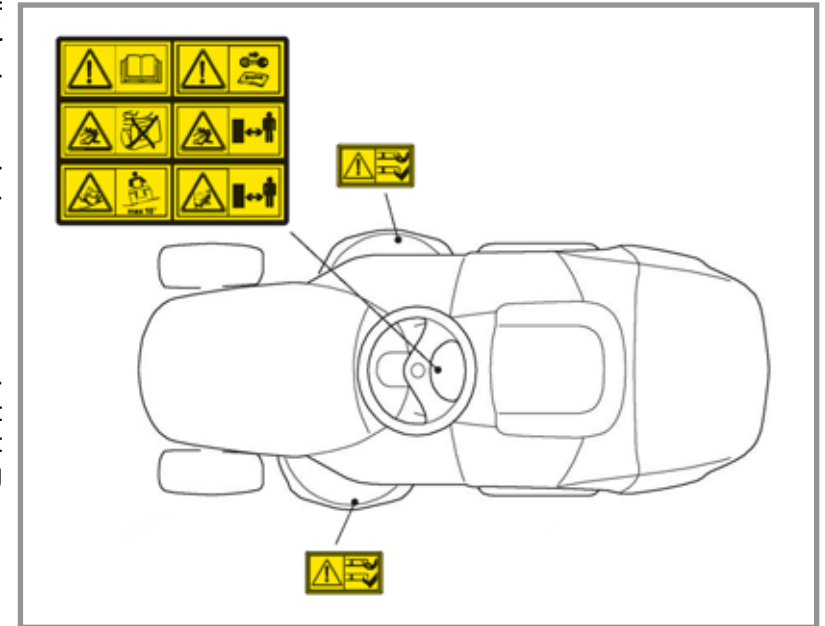

A) Occasional tuning

- Check working order of safety devices and renew illegible or missing labels, following the layout below
- Check tyre pressures
- Clean air filter
- Check engine oil level
- Check for fuel leaks
- Aligning the cutting deck
- Sharpen and balance the blades and check the condition of the hubs
- Check for wear in the belts
- Check the blade brake engagement
- Grease front wheels lever joint pins and bushes
- Check tightness of engine screws
- Check all those items indicated in the engine manual

B) Routine maintenance

- All work carried out in section a), plus:
- Check battery charge
- Check tension of belts
- Adjust drive engagement
- Adjust brake
- Adjust blade engagement
- Adjust blades brake
- Check steering allowance
- Check front bearings
- General lubrication
- Clean away grass cuttings and wash exterior
- Clean and wash inside cutting deck and collector channel
- Clean and wash grass-catcher
- Touching up of any damaged paint

General informations

This chapter helps achieve a rapid identification and solution to the most recurrent problems, classified according to the operating unit in question.

Related topics

Map of functional units

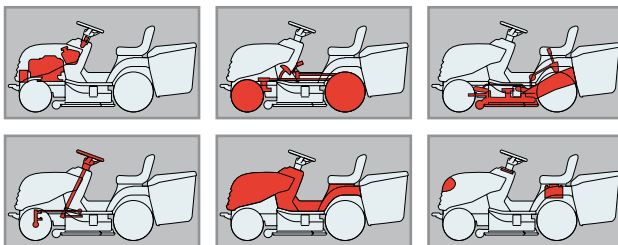

1. Engine and Tank

Problem	Probable cause	Solution	
Starter motor does not run	Low battery	Recharge	[7.9]
	No starter relay contact	Check	[7.6]
	Faulty connector and/or starter motor failure	Check and/or replace	[*]
The starter motor runs but the engine does not start	Blown spark plug electrode	Replace the spark plugs	[*]
	Uncertain connections	Check the connectors	-
	Coil failure	Check and/or replace	[*]
	The carburettor solenoid valve does not open	Check	[*]
The engine runs irregularly and/or lacks power	No fuel is pumped to the carburettor	Check the filter, fuel pump (if applicable) and the carburettor	[*]
	Faulty ignition	Check the spark plugs and ignition system	[*]
Dense and/or blue exhaust fumes	Low fuel level in the tank	Top up	-
	Dirty or old fuel	Empty the fuel tank and add fresh fuel	-
	Clogged carburettor filter	Check and clean	[*]
Black exhaust fumes	Excessively oily carburetion	Check the starter and command cable	[*]
Engine overheating	Spark plugs with inadequate heat rating	Check	[*]
	Carburetion problems	Check the carburettor	[*]
	Insufficient oil level	Check and top up	[*]
	Clogged suction system	Check and clean the air filter and the suction pipe	[*]
	Dirty cooling flaps	Clean	[*]
Engine idling speed is too high or too low.	Broken cooling fan	Replace	[*]
	Incorrect cable adjustment	Adjust	[6.8]
Abnormal noise and vibrations	Loose bolts and screws	Check and tighten to the prescribed values	[5.5]

[*] Check the engine Manufacturer's Manual

Important informations

Characteristics of the original belts

The standard belts on the market have different characteristics compared to the requirements of the original spare belts, supplied by the authorised dealer. The latter are designed and manufactured in close cooperation with the belt supplier and the machine manufacturer.

Here are the reasons why it is important to choose an original belt, useful when making such decisions..

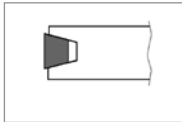

a) Adhesion on the pulley. The belt rests with the sides inclined against the walls of the pulley. There must be a gap between the belt and the bottom of the groove.

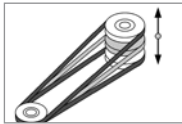

b) Floating pulley on cutting equipment. The original Power Take Off (PTO) belt is designed to work even if the pulleys move up and down and tilt at the same time.

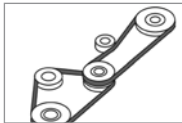

c) Curvature in two directions. All the original belts, which work with tensioning arms acting on the external side, are equipped with reinforcements. The reinforcement is designed specifically for these specific cases..

2. Transmission - Brakes - Wheels

Problem	Probable cause	Solution	
The machine moves slowly, loses power or doesn't move at all	Slack belt	Adjust	[4.3]
	Worn or oily belt	Replace	[6.4]
	Broken pulleys	Replace	[5.5] [*]
	The brake is not adjusted correctly	Check and adjust	[4.2]
	Hydrostatic unit failure ¹⁾	Check the Manufacturer's Instruction Manual.	[*]
The machine will not move in either direction	Pulley splines broken	Replace	[*]
	Hydrostatic unit failure ¹⁾	Check the Manufacturer's Instruction Manual.	[*]
The machine does not reach the foreseen speed in forward drive ¹⁾	Incorrect pedal adjustment ¹⁾	Adjust	[4.4]
Uncertain or ineffective braking	The brake is not adjusted correctly	Check and adjust	[4.2]
Hydrostatic unit overheating ¹⁾	Insufficient oil level ¹⁾	Top up	[*]
	Clogged oil filter ¹⁾	Clean and/or replace	[*]
Abnormal noise and vibrations	Slack or worn belt	Check and/or replace	[6.4]
	Irregular fan rotation	Check the condition of the fan, that it is securely fastened in place and that nothing interferes with the rotation movement	[*]
	Incorrect positioning of the by-pass valve ¹⁾	Check and adjust	[*]
	Loose bolts and screws	Check and tighten to the prescribed values	[5.6] [5.6a]
The machine moves in neutral gear ¹⁾	Incorrect micro-switch adjustment ¹⁾	Adjust	[4.4]
	Slack or worn linkage system ¹⁾	Check and/or replace	[4.4]
Pushing the machine by hand is difficult ¹⁾	By-pass partially enabled ¹⁾	Check	[*]
The parking brake does not stop the machine on a 30% slope	Incorrect brake adjustment	Adjust	[4.2]
Excessive clearance on the front wheels	Worn bearings	Replace	[6.2]

¹⁾ Hydrostatic drive models

[*] Check the transmission unit Manufacturer's Instruction Manual.

Important informations

Characteristics of the original blades

The original blades have design, material and processing characteristics optimised for use on the equipment for which they were designed; these characteristics are not present in so-called "compatible" spare parts.

Here are the reasons why it is important to choose an original blade, useful when making such decisions.



a) No breakage of the blade ends. Using steel balls, the manufacturer simulates what can happen when mowing over any foreign

bodies on the lawn. This can ruin the blade edge, but no component can come loose, fall off or be hurled away.



b) No breakage of the blades. The impact test is the most severe durability test that any lawnmower can be subjected to. An iron tube is

placed exactly inside the blades when the mower is running. The blade may deform but it will never, under any circumstances, fall off or break. This test verifies that blades and other components meet the high safety requirements.

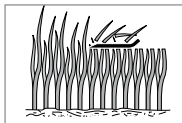

c) Excellent cutting result. The blades and blade ends supplied by the authorised dealer are optimised for the application for which

they are intended. In short, this means that the blades are suitable for the shape of the casing and to the number of revolutions to provide the best possible cutting result.

3. Cutting deck

Problem	Probable cause	Solution	
The blades do not engage or do not stop promptly within 5 seconds when they are disengaged	Slack belt	Adjust the engagement	[4.1]
	Incorrect adjustment of the engagement spring	Adjust the engagement	[4.1]
	Electromagnetic engagement problems	Check and/or replace	[7.5]
Uneven mowing	Cutting deck not parallel to the ground	Check the tyre pressures Align the cutting deck with the ground	[6.1] [4.5]
	Blades cutting badly	Check their condition and that they are well sharpened	[4.9]
	Misaligned blades	Check the blade shafts and flanges	[4.8]
Abnormal noise or vibrations	Loose joint bolts and screws	Check and adjust	[5.7]
	Pulleys or guide pulleys are worn and do not rotate correctly	Check and/or replace	-

4. Steering

Problem	Probable cause	Solution	
Excessive clearance on the steering wheel	Worn pinion and crown teeth	Adjust and/or replace	[4.6] [6.3]
The machine does not maintain a straight line when the steering wheel is straight	Incorrect tie-rod adjustment	Adjust	[4.7]

General informations

The blades are driven by the engine by means of a "V" belt and are engaged by an electromagnetic clutch.

After a certain amount of use the belt can become longer which can result in malfunctioning, i.e.:

- belt slipping = belt stretched
- difficulty in disengaging, with the blades continuing to run = belt shortened

In both cases the stretcher needs to be adjusted. Disengaging the blades causes the cutting in of a brake, incorporated in the electromagnetic clutch, whose task is to stop the blades from rotating within five seconds.

Related topics

[🔧 5.2] Removal of the side guards (if provided)

[🔧 6.6] Replacement of the blades control belt

[🔧 7.5] Electromagnetic clutch check

Map of functional units

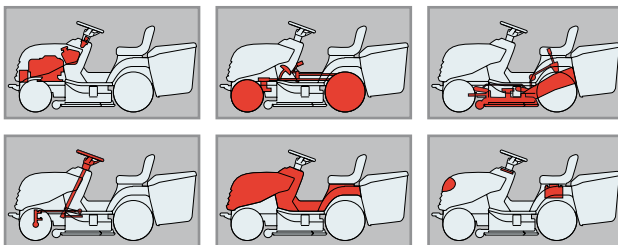

A) Adjusting blade engagement

- 🔧 Remove right side guard (if provided)

With the cutting deck in its lowest position, suitably turn the adjuster nuts (1) until the spring (2) reaches the length "A" 82 - 85 mm, measured from the outer edge of the eyelet with the blades engaged.

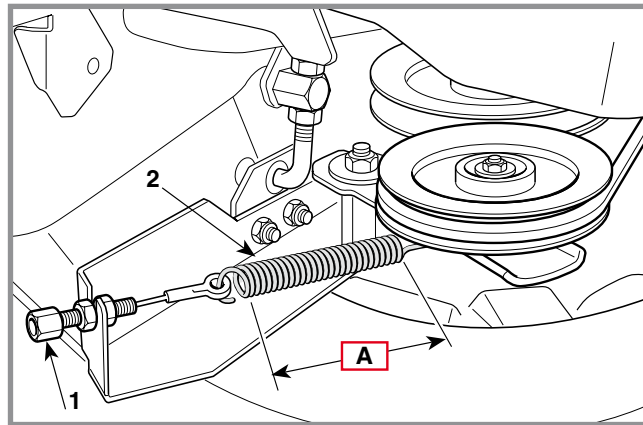

- ⚠️ **WARNING!** Reassemble right side guard (if provided)

B) Checking the blade brake

⚠️ **WARNING!** Correct operation of the brake, which must ensure that the blades stop within 5 seconds from disengagement; longer stopping times do not comply with the safety standards.





If the blades do not stop within 5 seconds from disengagement, appropriate checks must be made to the electrical system and the clutch must be replaced if no result is achieved.

BRAKE ADJUSTMENT

General informations

Reduced braking power is corrected by adjusting the spring on the brake rod.

Related topics

-  **1.1** Identification of transmission unit
-  **5.6** Removal of the rear axle (Peerless MST 205-535 E)
-  **5.6a** Removal of the rear axle (Hydro-Gear T2-ADBF-2X3C-1RX1)
-  **6.10** Replacement of the brake pads and disc

Map of functional units

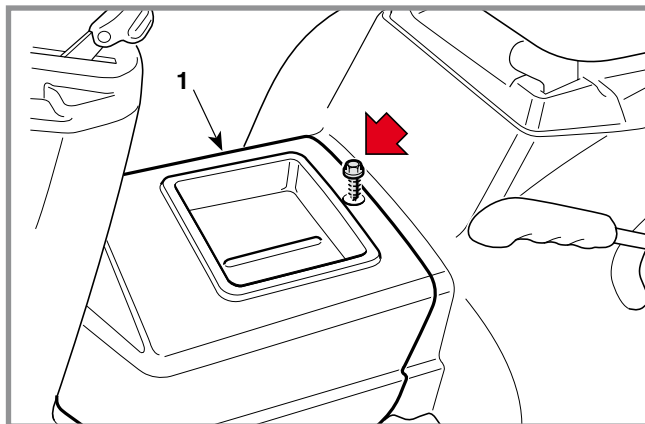
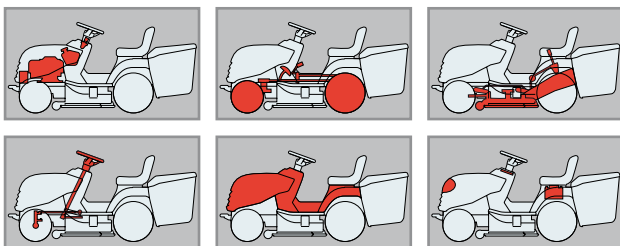

The brake adjustment spring can be accessed by removing the inspection hatch (1).

The adjustment is to be made with the parking brake engaged and consists of altering the length of the spring (2) to the best measurement. The braking capacity is increased by screwing the nut down on the rod (and thus shortening the length of the spring).

Loosen the nut (4) which retains the bracket (5) and then turn the nut (6) so that the length «A» of the spring (2) is:

- **mechanical drive models**
- 43,5 - 45,5 mm (Peerless MST 205-535 E)

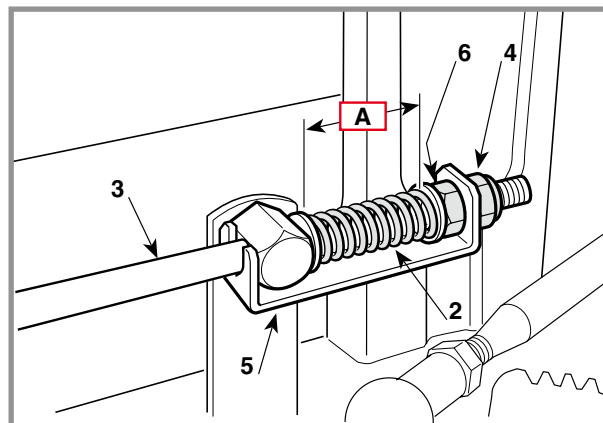

- **hydrostatic drive models**
- 40 - 42 mm (Hydro-Gear T2-ADBF-2X3C-1RX1)

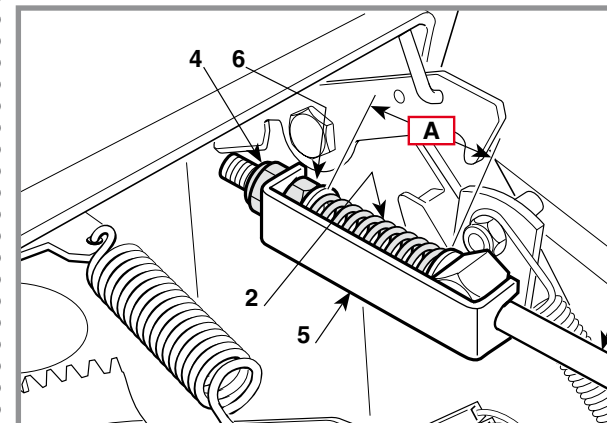

measured from the inside of the washers. When the adjustment has been made, tighten the nut (4).

NOTE Never go under these amounts to avoid overloading the brake unit.

 **WARNING!** When the adjustments have been made, the parking brake should prevent the machine from moving on a slope of 30% (16°) with the driver in position.

If braking is still poor or uneven even after having made the adjustment, proceed as under indicated, according to the type of transmission fitted on the machine.

- **mechanical drive models**

Remove the control rod (3) from the lever (7) and check that this lever has a free movement of 20 mm (measured vertically next to the pin rod) before beginning the braking action. If this is not the

BRAKE ADJUSTMENT

case, the free movement can be adjusted with the screw (8), unless the brake pads or discs are so worn that they need replacing.

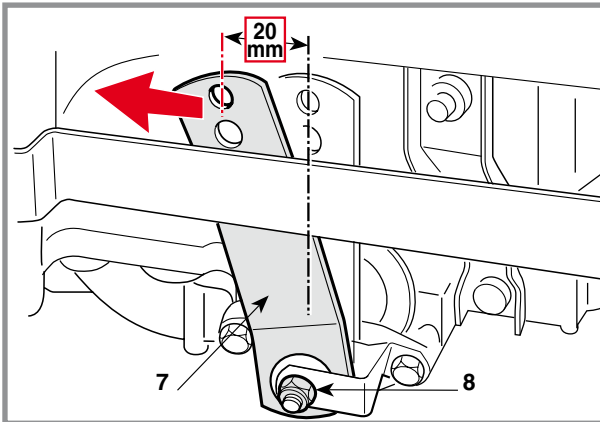
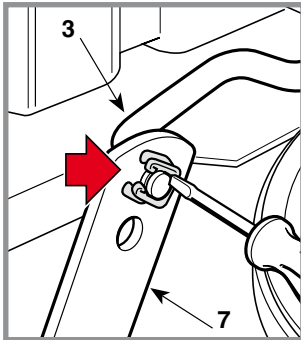

When connecting the rod (3) be sure to use the uppermost hole in the lever (7) and to replace the washer (9); then check the length of the spring again (2).

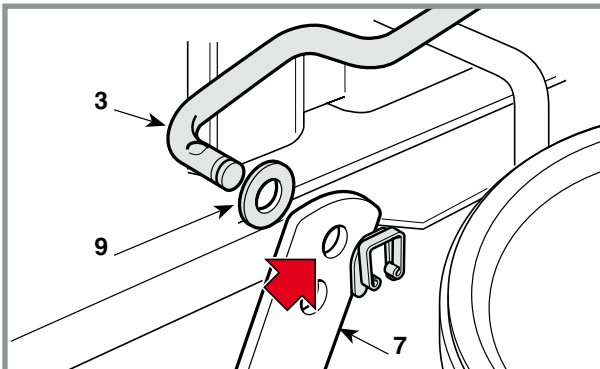

► **hydrostatic drive models**

You cannot make any further adjustments from the outside. Therefore you need to dismantle the whole rear axle of the machine and contact one of the manufacturer's Service Centres.

DRIVE BELT ADJUSTMENT

CHAPTER	REVISION	FROM ...	PAGE
4.3	0	2018	1 of 1

General informations

If it seems that the forward drive is not working properly after a long period of use or after replacing the belt, this may be caused by a change in the length of the belt.

- A loose belt reduces output from the drive and limits forward movement power;
 - a belt which is too tight increases noise and results in jerky movements or tipping up when engaging the drive.
- In both cases the stretcher needs to be adjusted.

Related topics

[6.4](#) Replacement of the drive belt

Map of functional units

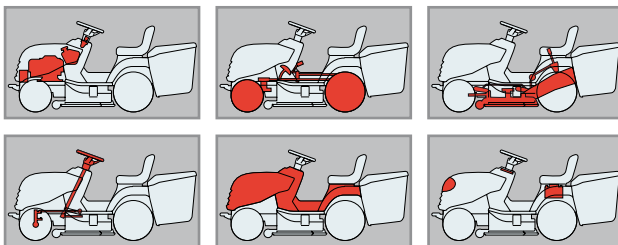

The adjustment spring can be accessed by removing the inspection hatch (1).

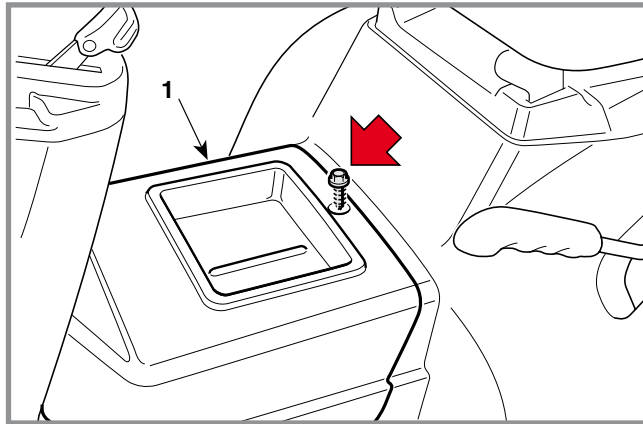

Correct spring tension (2) is obtained by moving the hook to one of the slots (3) until a measure "A" is obtained of 156-160 mm, measured on the outside of the fittings, with the transmission commands disengaged and parking brake off.

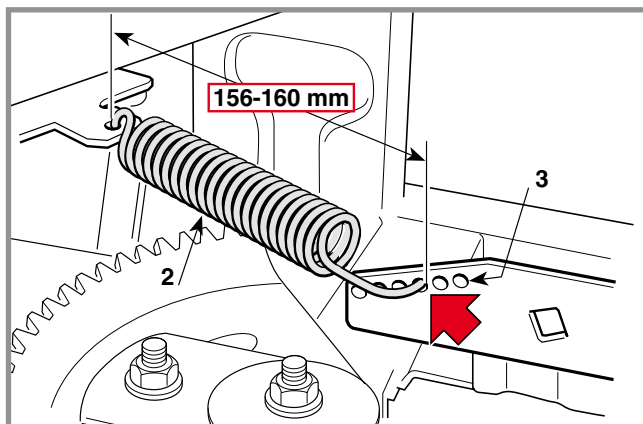

! Moving the spring (2) requires a certain effort and is easier when a specific tool (4) is used to hook and move the end of the spring.

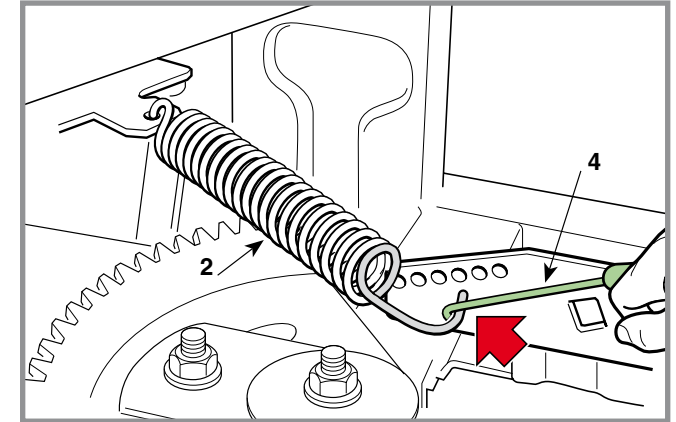

General informations

This operation should be carried out every time the rear axle, pedal or control rod is removed, in order to get the correct travel for the pedal and to reach the envisaged speeds both forwards and in reverse.

Related topics

[\[7.10\]](#) Fitting safety microswitches

Map of functional units

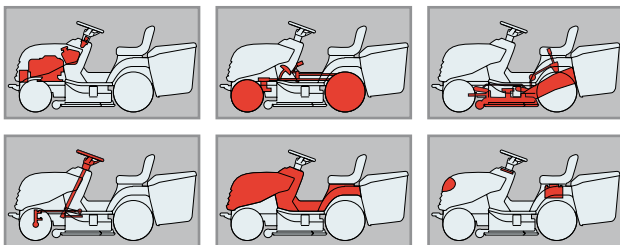

► hydrostatic drive models only

All the adjustment elements can be accessed by removing the inspection hatch (1).

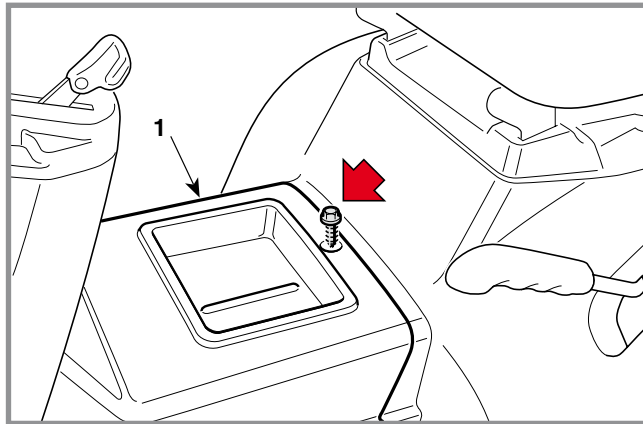

A) Adjusting the pedal in the “neutral” position

Regulating consists of adjusting the position of the pedal (3) with the hydrostatic group lever (2), which is brought to the forward maximum speed position by a spring.

To get the speeds that both forward and reverse gears

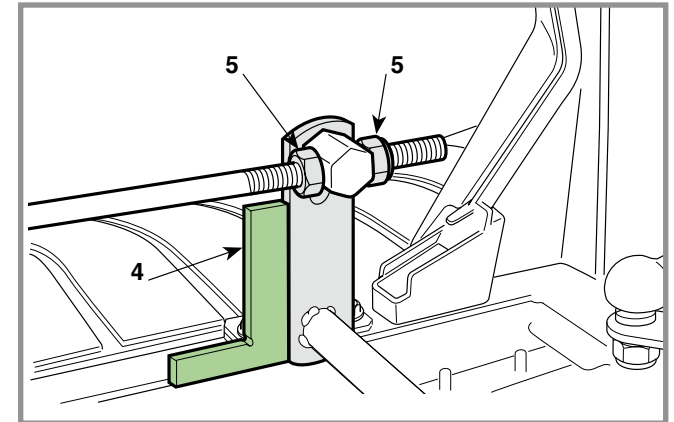
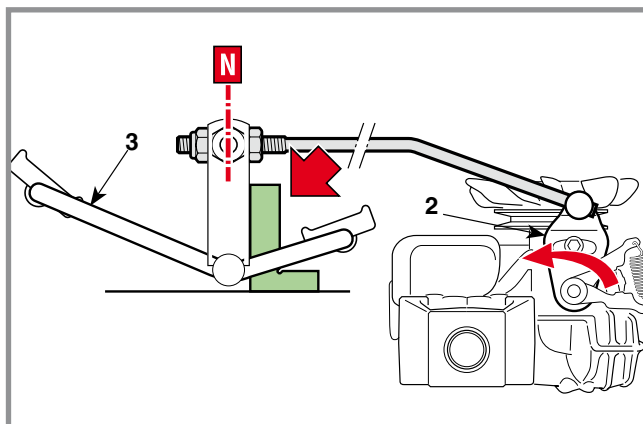

provide (and consequently determine the “neutral” position for the pedal), it is necessary that the inner lever (3) on the pedal axis is located perfectly vertical with the lever (2) of the hydrostatic unit in “neutral”.

This is obtained using a bracket (4), by working on the nuts (5) until reaching the desired situation, taking care not to accidentally change the position of the lever (3) during adjustment.

When adjustment has been completed, move the pedal (6) to the reverse position and check that the lower section (6a) touches the footboard.

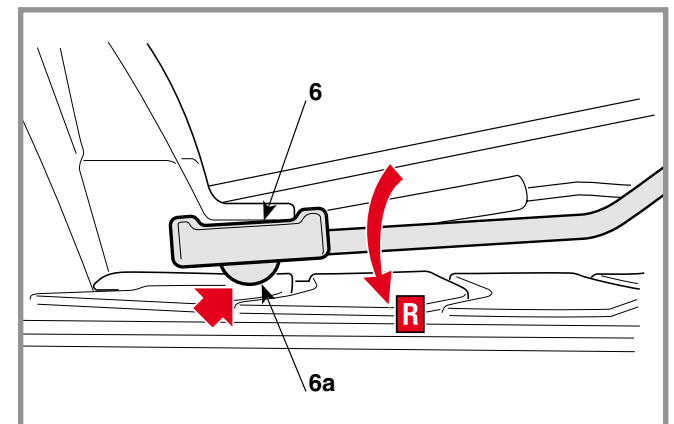

B) Adjusting the “neutral” position of the microswitch

! **IMPORTANT** *This is a very important adjustment for the correct operation of the safety devices for starting and stopping of the machine during work.*

The neutral position “N” is signalled by the microswitch (11) of the cam (12).

After checking that the adjustment “A” has been correctly completed, make sure that the pedal is released and in neutral “N” then loosen the fastening screws (13) of the microswitch and position it in line with the tip of the cam, so that it stays pressed down.

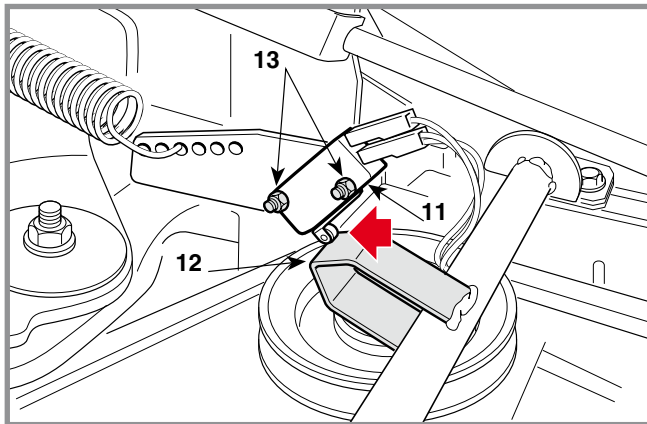

By moving the pedal to the forward gear, neutral position and reverse gear you should hear the click of the button at each gear change before the wheels start moving.

ALIGNING THE CUTTING DECK

CHAPTER	REVISION	FROM ...	PAGE
4.5	2	2018	1 of 2

General informations

The cutting deck is lowered by a level controlled cable, and is moved by two trace rods at the front and back.

In order to get a good cut it is essential that the cutting deck is parallel with the ground crosswise, and slightly lower at the front.

Two adjustments can be made on the jointed system of the cutting deck:

- a) a combined adjustment to the parallel and the minimum height front and back
- b) an adjustment to just the parallel across the cutting deck

Related topics

2.2] Tools

5.2] Removal of the side guards (if provided)

Tightening torques

Front	(Tyres 13 x 5.00-6)	1,5 Bar
.....	(Tyres 15 x 5.00-6)	1,0 Bar
Rear		1,2 Bar

Map of functional units

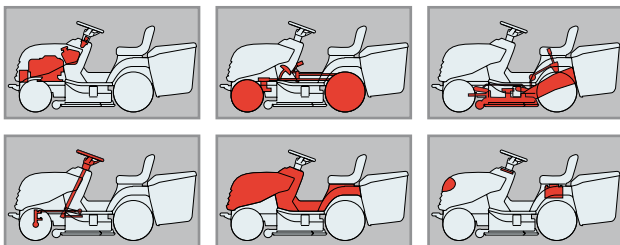

Remove the left and right side guards (if provided).

Check the tyre pressures. If one or more tyres have been replaced or you find differences in diameter, do **not attempt to compensate these differences by giving different tyre pressures**, but make the adjustments as in points «A» and «B».

A) Combined adjustment to the parallel and the minimum front and rear height

Put the lawn-tractor onto a flat and stable surface (such as a work bench) and put blocks beneath the cutting deck in line with the centre lines of the blades:

- at the front 26 mm (1)
- at the rear 32 mm (2)

Put the height lever in position «1».

Completely loosen the adjuster (3), the nuts (4 - 6 - 8) and the locknuts (5 - 7 - 9) of the three trace rods until the deck is resting on the blocks.

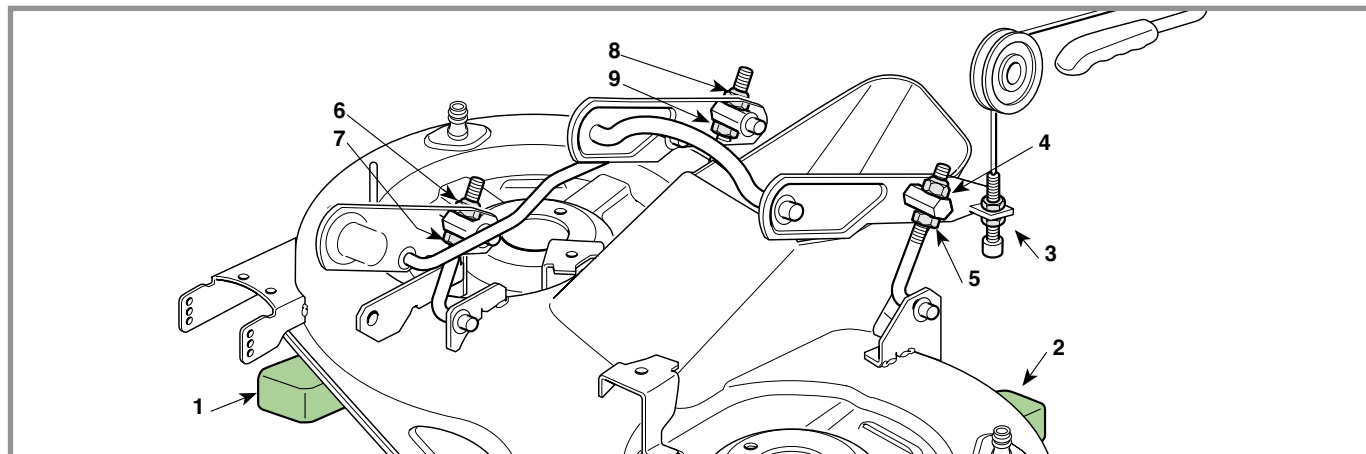
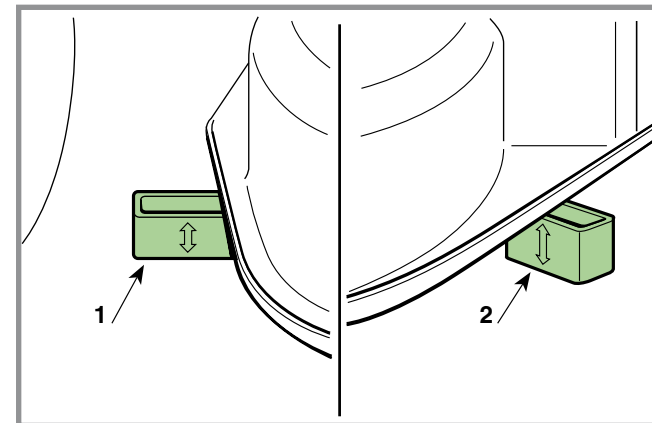
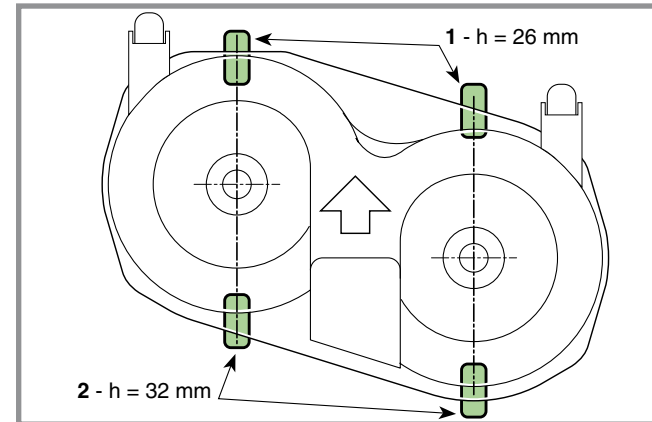

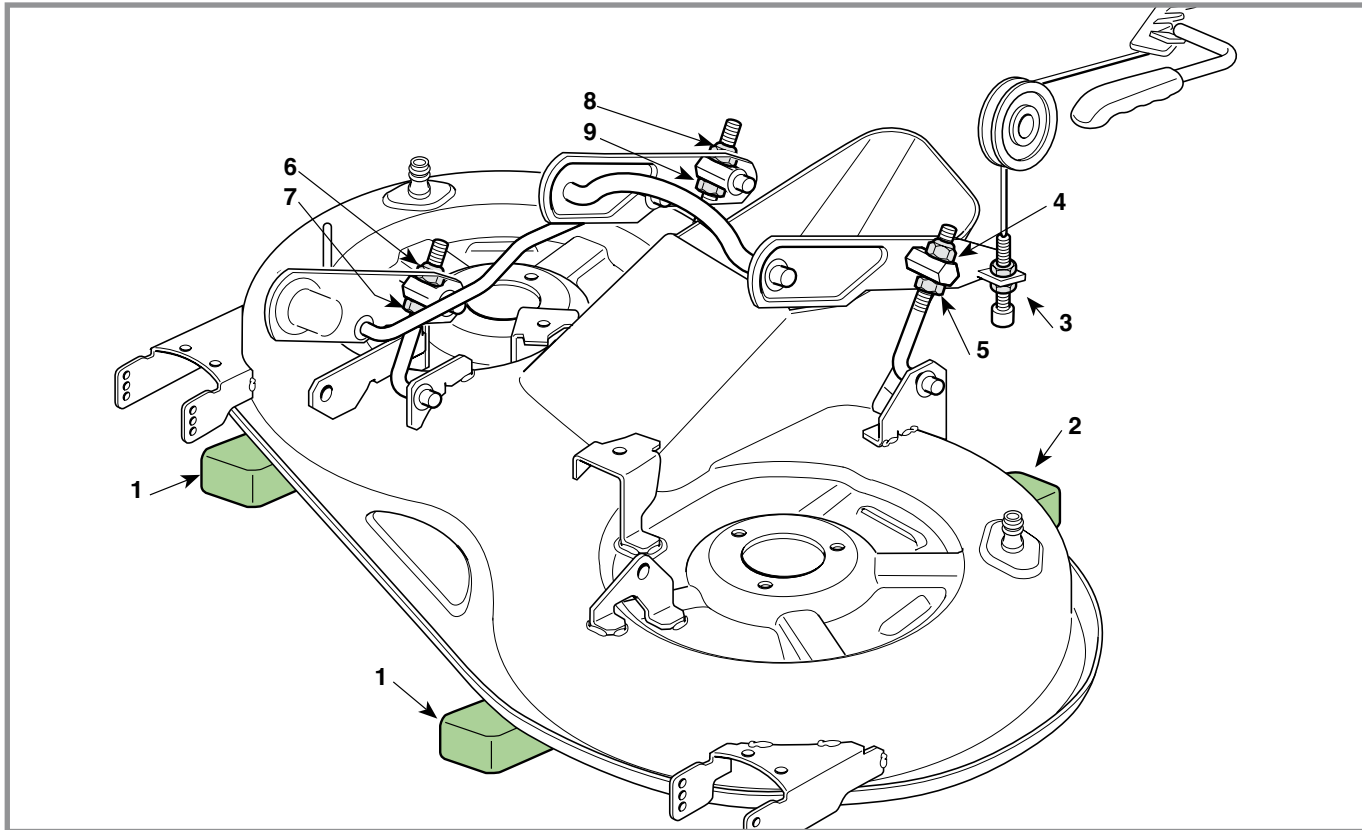

Turn the adjuster (3) until the control cable is taut.

Tighten the two right upper nuts (6 - 8) and the left upper nut (4) to the point where the deck just begins to lift, then tighten the three locknuts (5 - 7 - 9).

Remember to tighten all the nuts and locknuts once these adjustments have been made.

🔧 Reassemble the right and left side guards (if provided).

B) Adjusting the parallel across the cutting deck

Any difference in height from the ground between the left and right sides of the deck can be compensated by turning the two nuts (4 - 8) and locknuts (5 - 9) **of just the back rods**.

Remember to tighten all the nuts and locknuts once these adjustments have been made.

🔧 Reassemble the right and left side guards (if provided).

ADJUSTING THE STEERING PLAY

CHAPTER	REVISION	FROM ...	PAGE
4.6	0	2018	1 of 1

General informations:

Steering play must never be excessive in order not to effect driving precision.

Related topics:

Tightening torques

3 Nut for ring gear 25 ÷ 30 Nm

Map of functional units

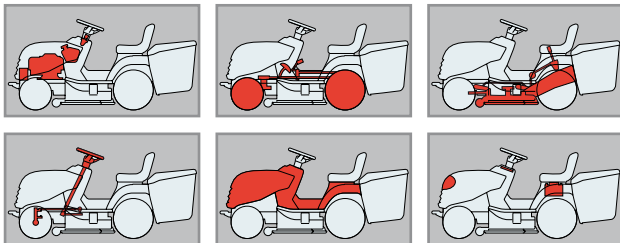

Check that the steering play is not caused by the slackening off of the tie-rod system and fully tighten all the tie-rod and ball joint nuts.

If the play is due to the crown wheel/pinion pairing, the position of the spacer, fitted to lift the crown wheel and reduce the gap between the teeth, must be changed.

Remove the inspection hatch (1).

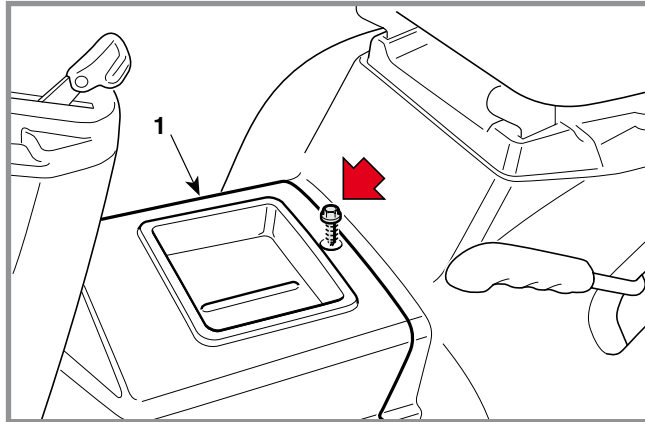

Unscrew the nuts (2) and (3) and remove the two cup washers (4) and (5) and the guide (6).

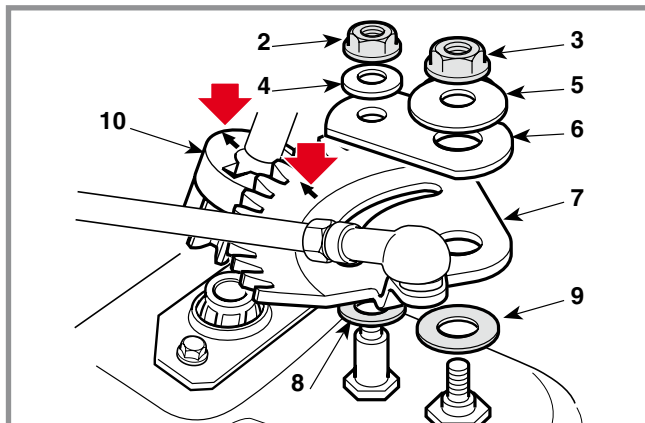

Remove the ring gear (7) and fit the two block washers (available as spare parts) (8) and (9) under it so as to place it in a higher position with respect to the pinion (10), reducing the gap between the teeth.

! Reassemble the ring gear matching the two references (⇒ <), punched on the ring gear (7) and on the pinion (10), in the drive direction.

Reassemble the nuts (2) and (3), tightening them to load the cup springs (4) and (5) as much as need to ensure steering manageability, without creating excessive play.

If the addition of a block (8) and another block (9) do not eliminate the play between ring gear pinion teeth, replace them since other block may not be added.

STEERING GEOMETRY ADJUSTMENT

CHAPTER	REVISION	FROM ...	PAGE
4.7	0	2018	1 of 1

General informations

The correct steering geometry is given by the values of the centre distance between the joints of the tension rod and the wheel connecting rod. Any faults caused by knocks or accidents result in reduced driving precision and increased wear on the tyres. These can be overcome as follows:

- uneven or excessive wear on the front tyres = incorrect toe-in
- the machine does not maintain a straight line when the steering wheel is straight = adjustment of tie-rods.

Related topics

Tightening torques

2	Connection rod fastening nuts	25 ÷ 30 Nm
8	Nut for articulated joint	45 ÷ 50 Nm

Map of functional units

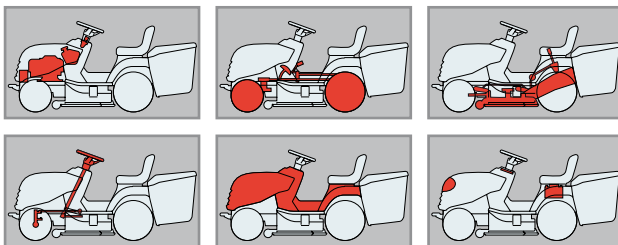

NOTE Before any other action, check that the joint fastenings have not worked loose.

A) Toe-in check

The gap between the connection rod holes (1) on the wheels ensures correct front wheel toe-in check without requiring adjustment.

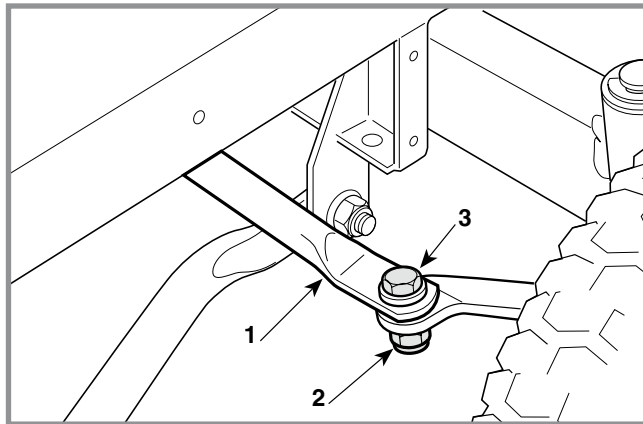

Toe-in check may only change due to rod deformation (1) or due to spindle bushing wear.

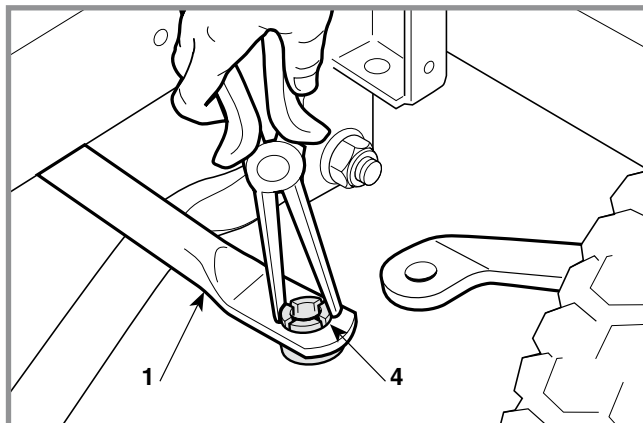

B) Adjustment of the steering wheel

To replace, unscrew the nut (2) with the screw (3) and remove the bushing (4) using pliers. Click the new bush (4) and tighten the nut (2) to the prescribed value.

Check that the toe-in is correct (point «A») and align the front wheels.

If the steering wheel is not straight, dismantle the articulated joint (5) and screw down or up on the tie-rod (6) for the necessary amount.

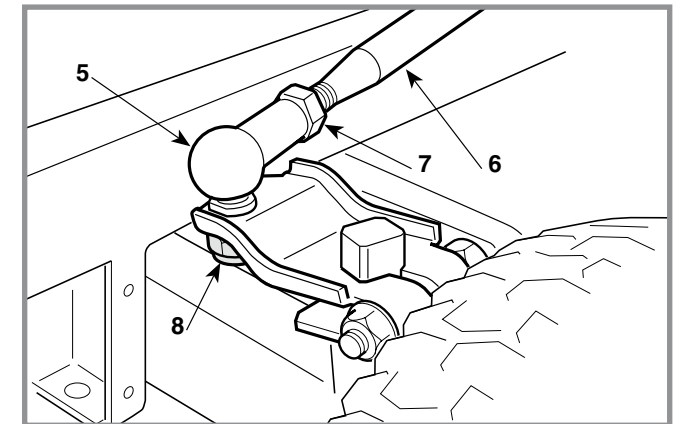

On assembly, fully tighten the locknut (7) and the fastening nut (8).

CHECKING BLADES ALIGNMENT

CHAPTER	REVISION	FROM ...	PAGE
4.8	0	2018	1 of 1

General informations

Excessive vibration when cutting and an uneven cut can be due to misalignment of the blades owing to deformation of the flanges or the shafts as a result of accidental knocks.

Related topics

[🔧 2.3] Vertical positioning

[🔧 5.7] Removal of the cutting deck

[🔧 6.7] Replacement of the supports and shafts of the blades

Map of functional units

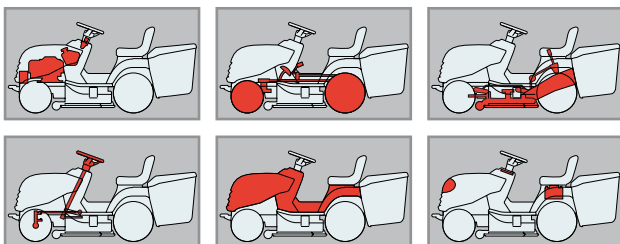

- ☛ Put the machine into a vertical position or:
- ☛ Remove the cutting deck.

⚠ WARNING! Always wear strong gloves when handling the blades.

⚠ WARNING! The blades are connected to each other, the rotation of each blade engages the rotation of the other.

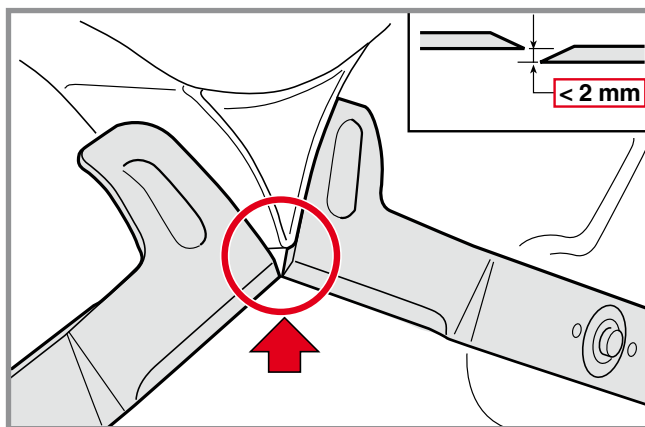

With the blades disengaged, firmly hold each blade and bring the cutting edges together in the various positions possible (A-B; A-B1; A1-B1; A1-B); at each position they should be aligned to within 2 mm.

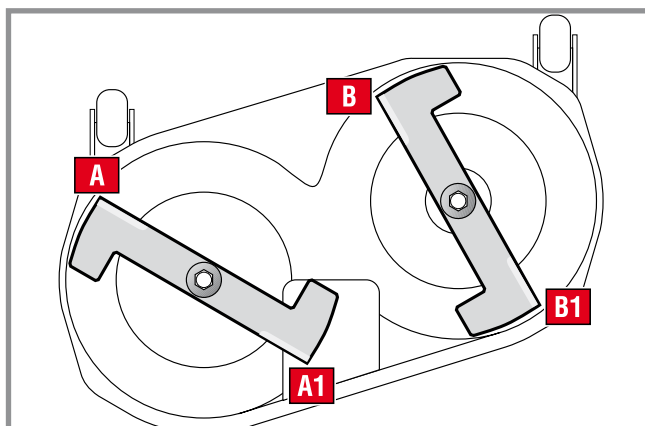

If higher amounts are found, check that the blades are not distorted. If this is not the case, check the supports or the shafts for the blades [see 6.9], replacing if necessary, and check the condition of the point where the flanges rest on the cutting deck.

⚠ IMPORTANT - Always replace damaged blades and do not attempt to repair or straighten them. Always use manufacturer's genuine spare parts!

General informations

A badly sharpened blade causes grass to become yellow and reduces grass collection capability. If not balanced, excessive vibration can be caused during use. Fins on broken, bent or damaged blades reduce the grass expulsion force and can cause damage and injuries.

Related topics

[🔧 2.4] Vertical positioning

[🔧 5.7] Removal of the cutting deck

Tightening torques

1a Screw for left blade 45 ÷ 50 Nm

1b Screw for right blade 45 ÷ 50 Nm

Map of functional units

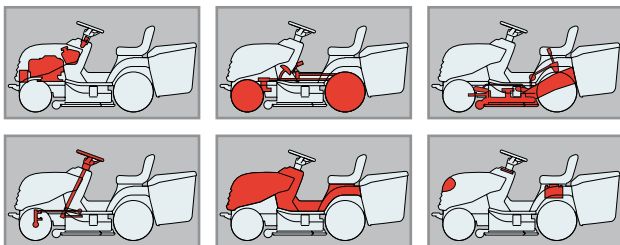

- ☛ Put the machine into a vertical position or:
- ☛ Remove the cutting deck.

⚠ WARNING! Always wear protective gloves when handling the blades and protect eyes when sharpening.

⚠ WARNING! The blades are connected to each other, the rotation of each blade engages the rotation of the other.

A) Removing and reassembling

For removing a blade it must be firmly held and the central screw (1) undone, bearing in mind that:

- the screw on the left blade (1a) is unscrewed anti-clockwise
- the screw on the right blade (1b) is unscrewed clockwise.

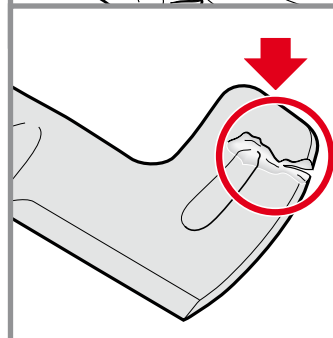
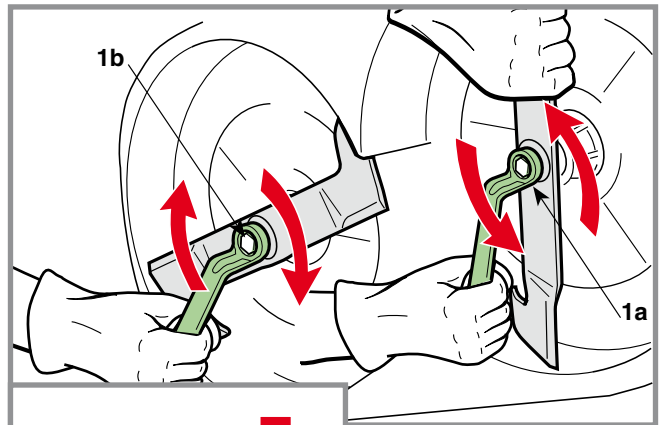

⚠ Always check that the fins are intact with cracks or breaks. Always replace damaged blades.

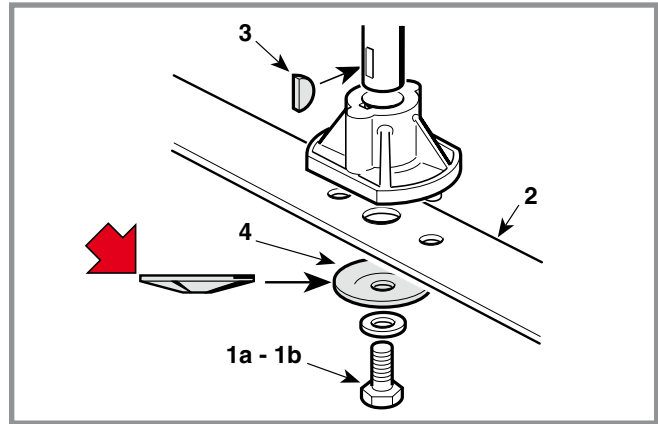

⚠ On assembly, be careful to:

- correctly position the keys (3) on the shafts;
- correctly locate the right and left blades, with the fins facing towards the inside of the plate;
- fit the flexible disc (4) so that the concave part is pressing against the knife;
- tighten the screws (1a - 1b) with a torque wrench set to 45-50 Nm.

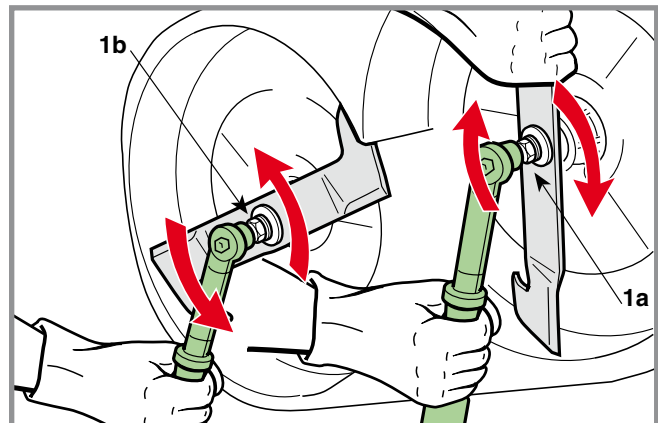

B) Sharpening and balancing

Always sharpen both cutting edges of the blade (2) using a medium grade grinder. Sharpening must only be done from the rounded side, removing as little material as possible.

The blade is to be replaced when the cutting edge has worn down to 10 mm.

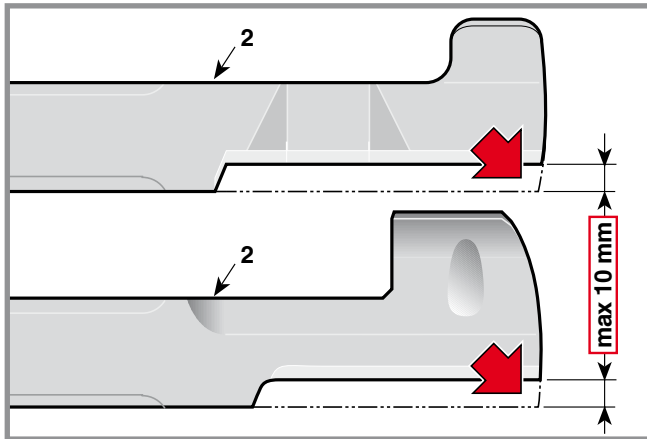

Using the appropriate equipment, check the balance to make sure that there is a maximum difference of 2 grams between one side and the other.

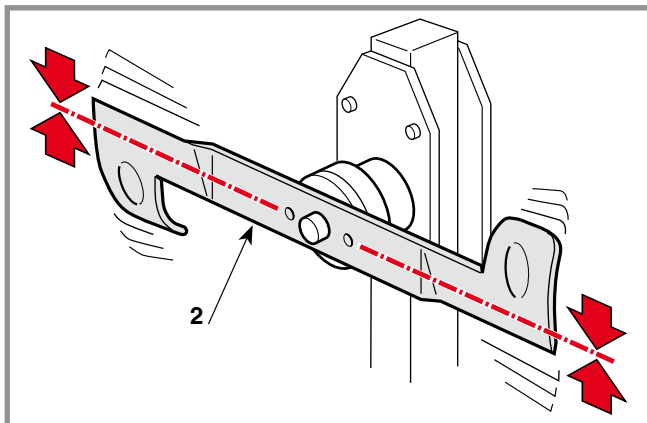

REMOVAL OF FRONT HOOD

CHAPTER	REVISION	FROM ...	PAGE
5.1	0	2018	1 of 1

General informations

The removal of the front hood gives greater accessibility to:

- the engine and its accessories
- the silencer and protection devices

Related topics

Map of functional units

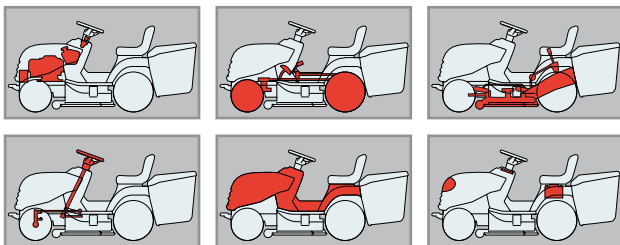

- ▶ **models with lights**
- The hood can be secured in two ways.

Take out the split pin (2) from the right-hand side and remove the hood (3) by moving it to the right.

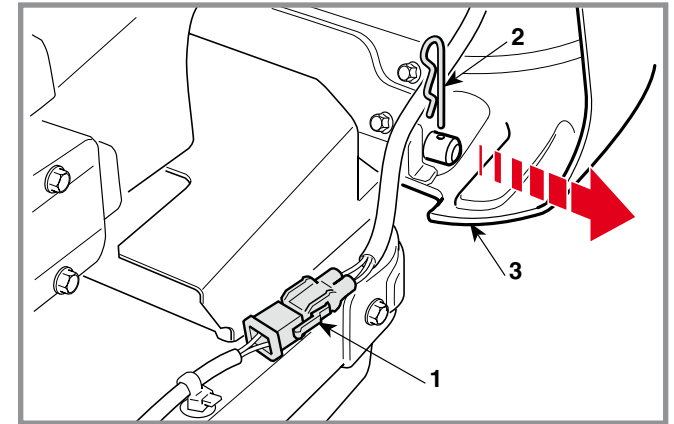

**REMOVAL OF THE SIDE GUARDS
(if provided)**

General informations:

The removal of side guards allows access to the blades drive belt and cutting deck adjusting keys.

Related topics:

Tightening torques

3 - 4 - 5 Guards fastening screws 8 ÷ 10 Nm

Map of functional units

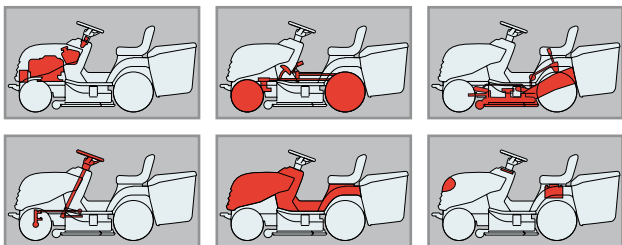

Each guard (1 - right) or (2 - left) is fastened by:

- 1 top self-tapping screw (3),
- 1 front self-tapping screw (4),
- 1 rear self-tapping screw (5),

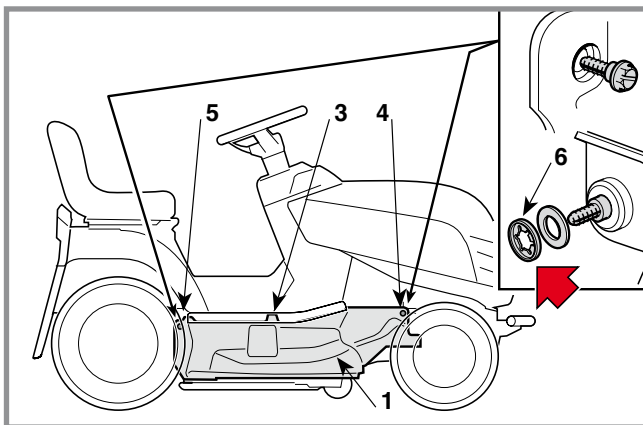

The front self-tapping screws (4) and rear (5) are held with a ring gear fastener (6) that keeps them inserted in the respective seats.

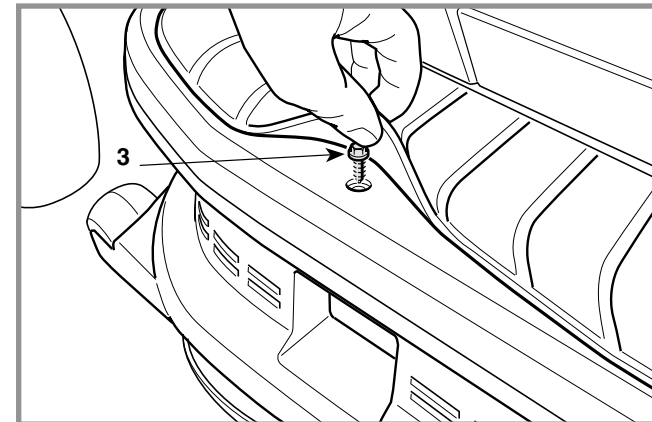
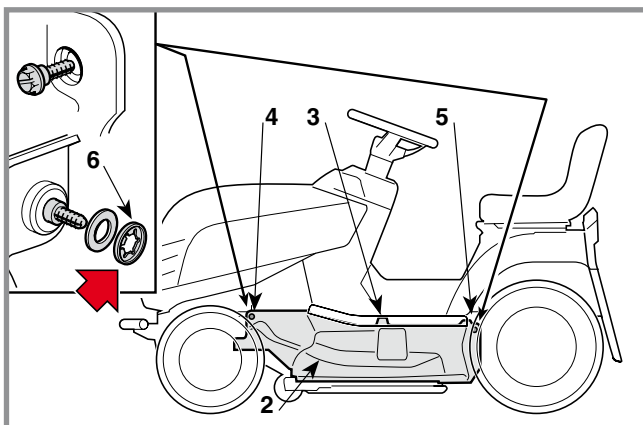

! **IMPORTANT** When assembling, ensure fasteners are used, being essential to allow disassembly and reassembly of the guards by user, without jeopardizing the safety of the machine.

REMOVAL OF THE WHEEL COVER

CHAPTER	REVISION	FROM ...	PAGE
5.3	0	2018	1 of 2

General informations

Complete removal of the wheels cover is required for its replacement and to access seat micro switch, placed below the two springs support cross-piece.

Related topics

 [5.2](#) Removal of the side guards (if provided)

Map of functional units

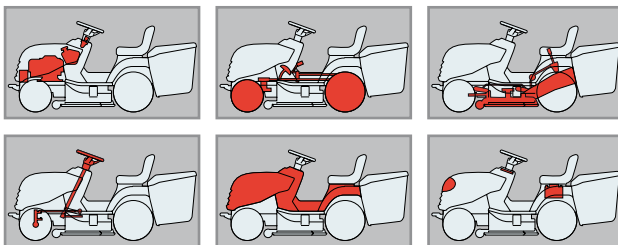

 Remove the left and right side guards (if provided).

Remove the inspection hatch (1).

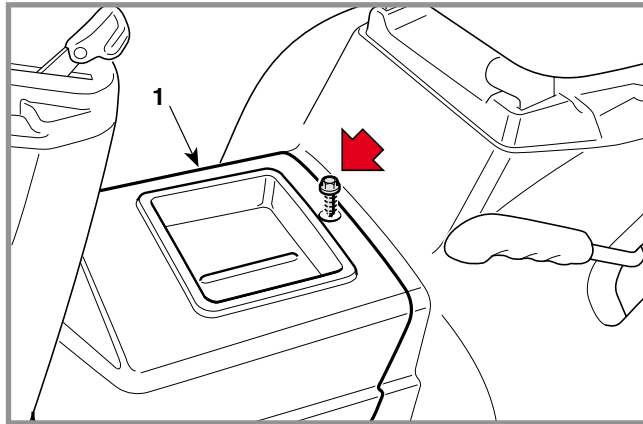

Bring the cutting deck to the highest position «7».

Remove the covering caps (2) and unscrew the two nuts (3) to remove the seat and the relative support plate (4).

Take off the spring (5) which holds the battery (6), taking care to prevent it accidentally short-circuiting. Disconnect and remove the battery (6).

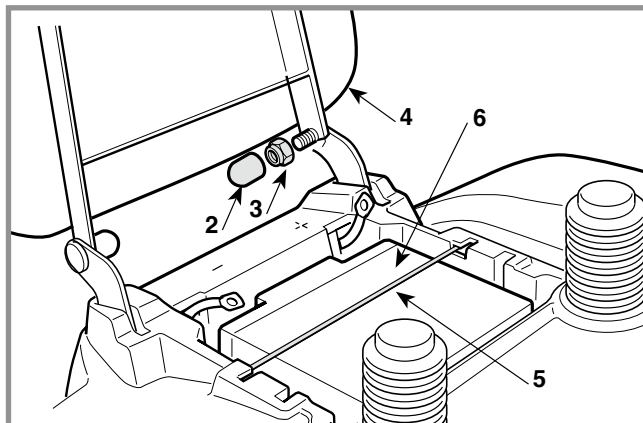

 **models with mechanical transmission:**
Remove the gear lever knob (7) from the lever (8).

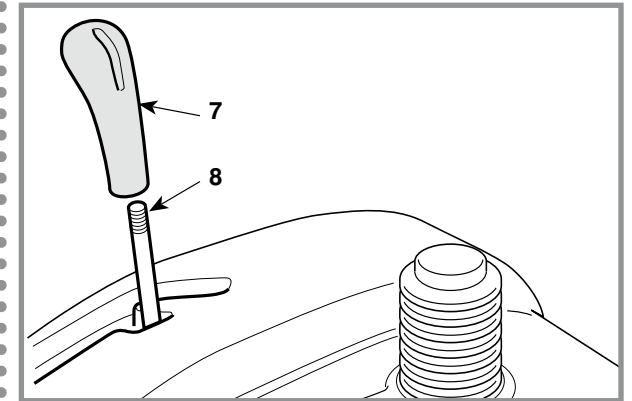

The cover (9) is held by:

– 2 screws (10) inside the battery compartment,

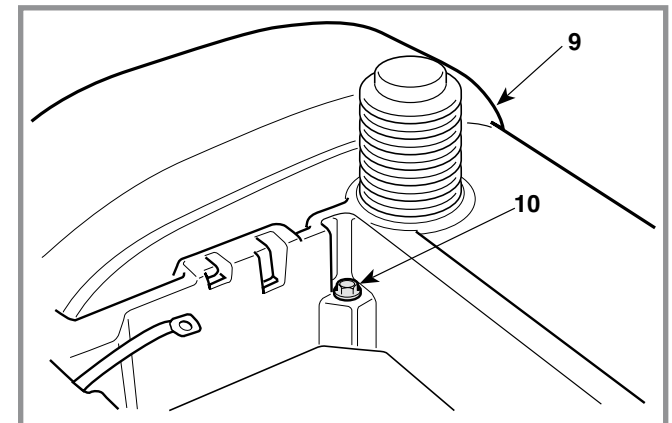

REMOVAL OF THE WHEEL COVER

CHAPTER	REVISION	FROM ...	PAGE
5.3	0	2018	2 of 2

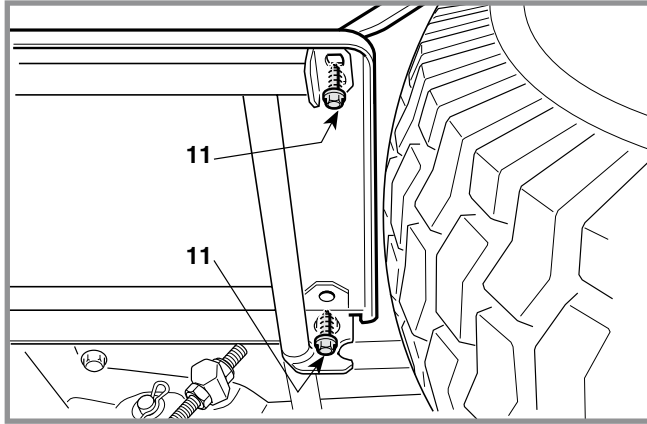

- 4 lower screws (11) (2 for each side) located under the external edge of the foot boards,
- 6 rear screws (12).

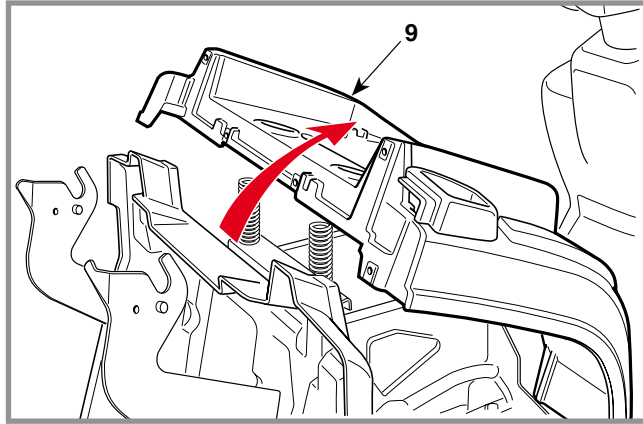
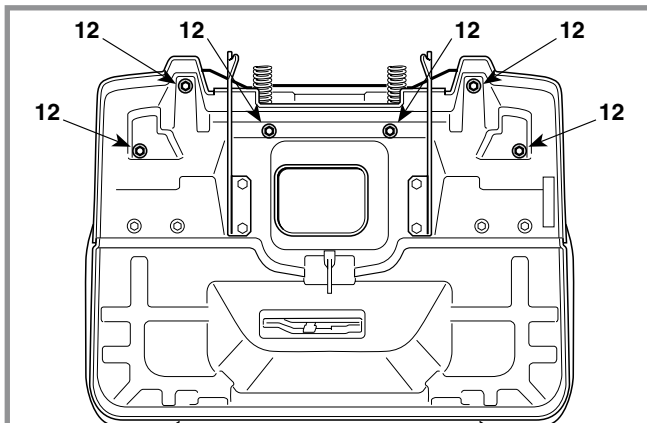

The removal of the cover (9) is facilitated by pushing it forward and simultaneously by lifting it from the rear.

On assembly, follow the procedures described above in reverse order.

Be careful to correctly reassemble the fitting (13) and properly insert the two side tongues (14) of the cover in the seats from the foot boards.

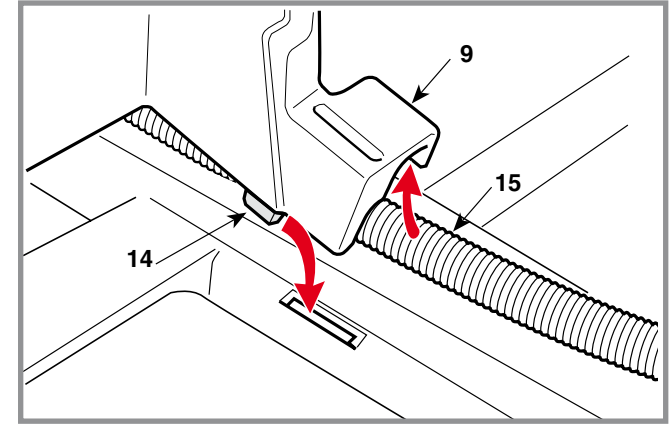
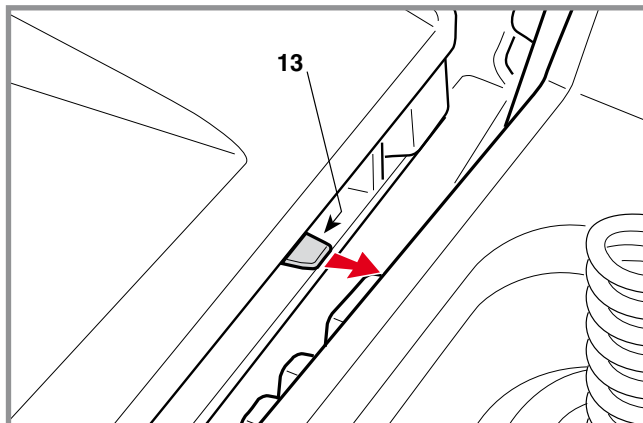

Correctly reposition the wiring sheath (15) in its housing on the right side of the cover.

☛ Reassemble the right and left side guards (if provided).

REMOVAL OF THE DASHBOARD

General informations:

Dashboard removal is only required for its replacement.

Related topics:

Tightening torques

11-12-13-14 Dashboard fastening screws 12÷15 Nm

Map of functional units

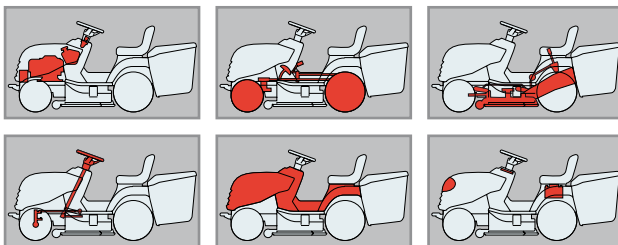

Using a screwdriver, unhook the two central hooks and two right and left hooks (1) that secure the steering wheel cover (2).

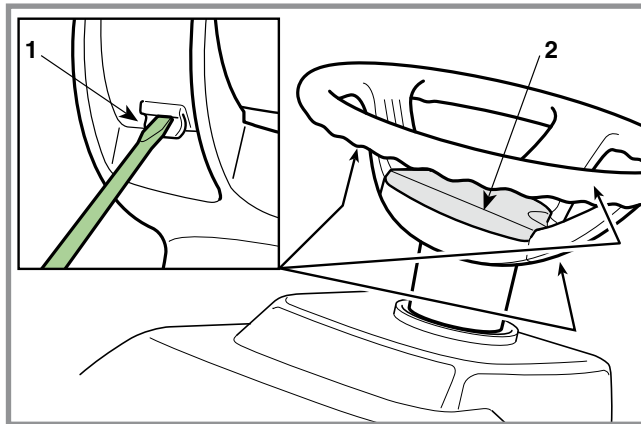

Unscrew the central screw (3) and remove the steering wheel (4) making sure to recover the spacer and washer (5).

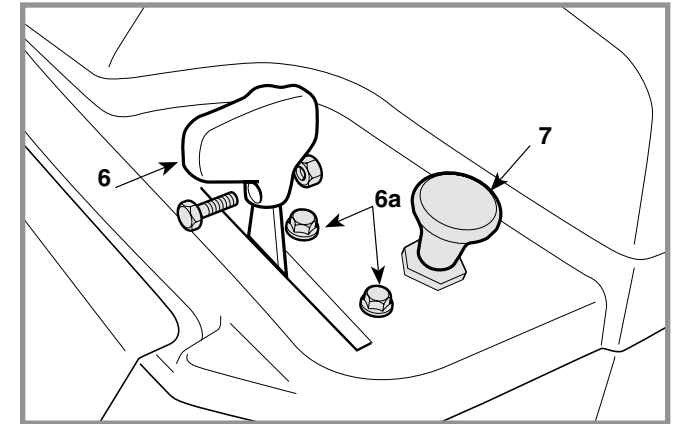
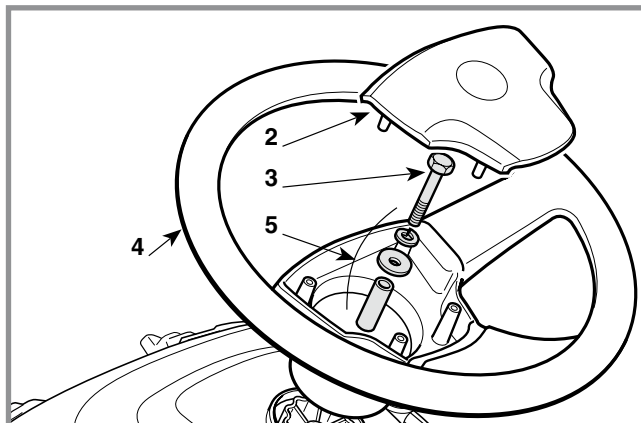

Unscrew the screw, take off the accelerator knob (6), then unscrew the accelerator fixing screws (6a).

Remove the starter control (7), where appropriate.

Unscrew the parking brake knob (8).

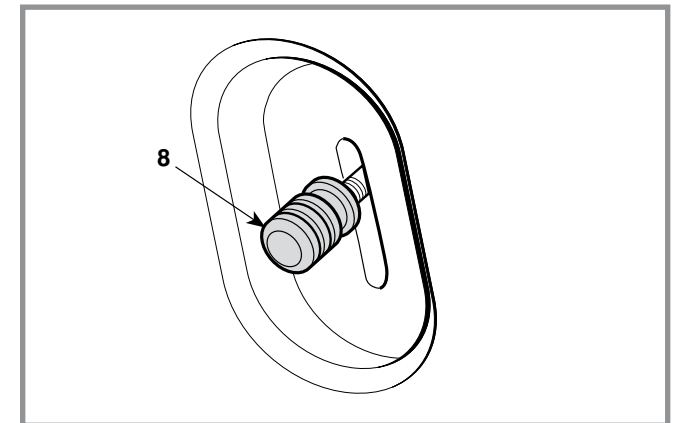

Disconnect all electrical connectors from their respective components:

- ignition key,
- blade engagement clutch switch,
- battery charge connector,
- fuses,
- electronic circuit board.

REMOVAL OF THE DASHBOARD

CHAPTER	REVISION	FROM ...	PAGE
5.4	1	2018	2 of 2

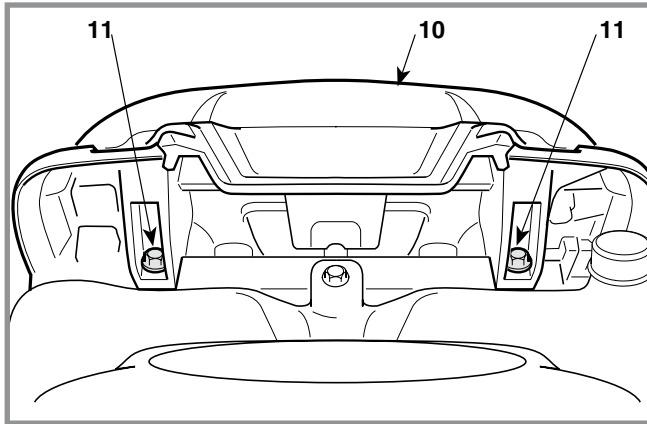

The dashboard (10) is held by:

- 2 upper frontal screws (11) inside the engine compartment,

- 2 lower frontal screws (12) (1 for each side) located inside the engine compartment,

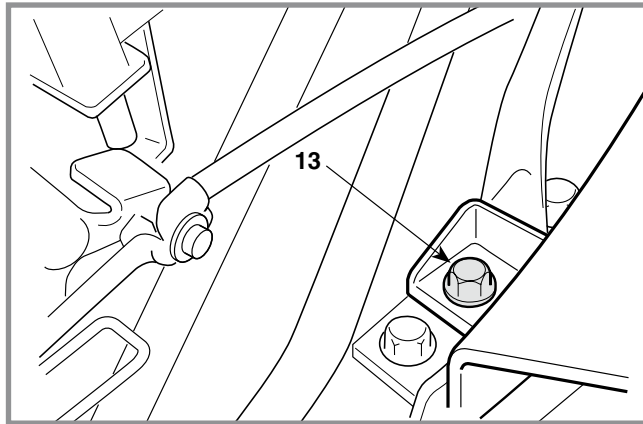
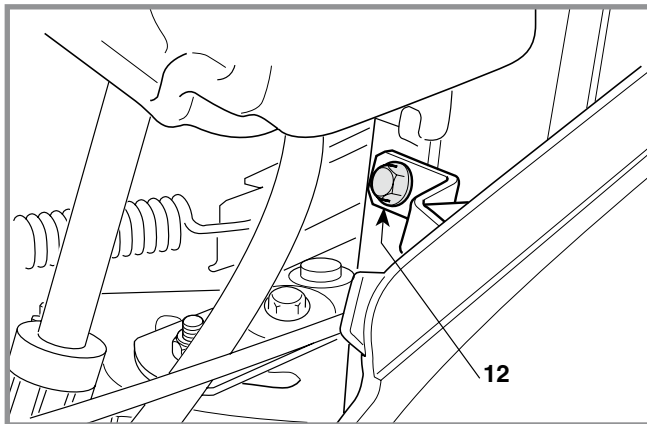

- 2 lower side screws (13) (1 for each side) located inside the engine compartment,

- 2 lower screws (14) (1 for each side) accessible after removing the central cover.

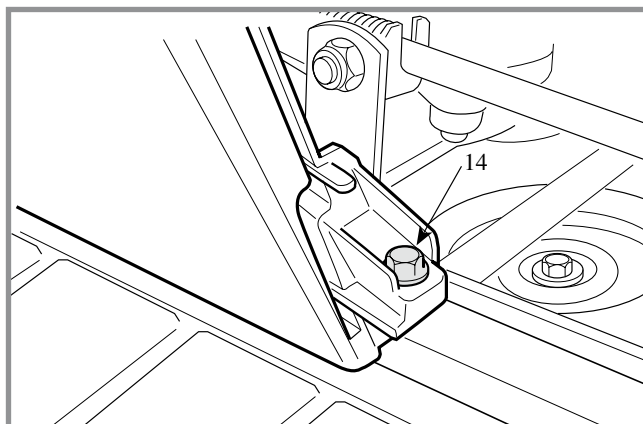

For assembly follow the operations described above in reverse order, making sure not to confuse the order of the screws (11) - (12) - (13) - (14) since:

- screws (11) - (13) - (14) have a stop that optimises use for plastic components;
- screws (12) do not have stops and are suited for metallic components.

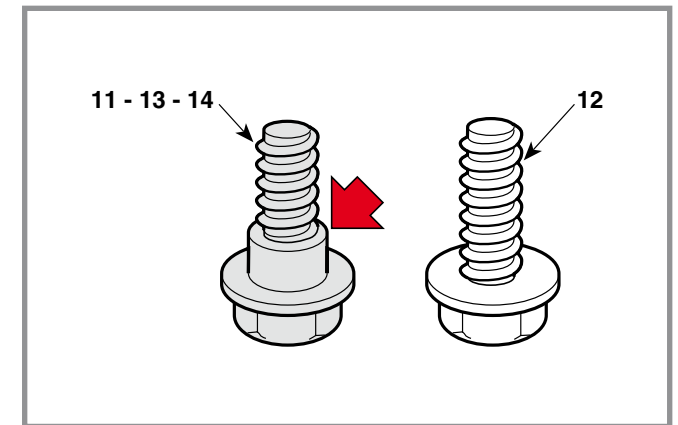

Correctly reposition the wire sheath (15) in its housing on the lower right-hand side of the dashboard.

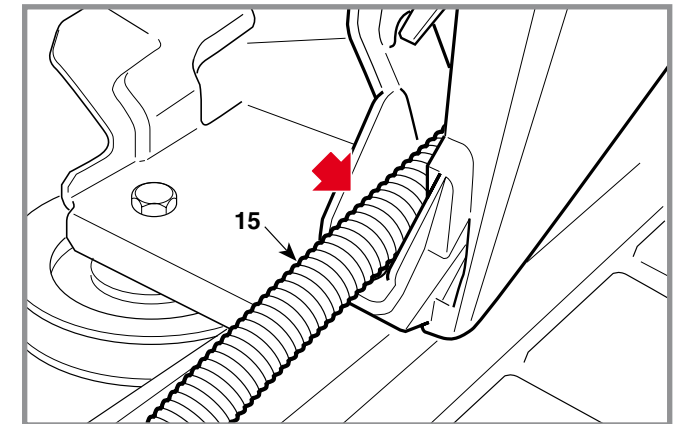

REMOVAL OF THE ENGINE

General informations

Since there are different types of drive, the stages described here refer to those shared or similar in all types of engine.

Related topics

[🔧 5.1] Removal of front hood

[🔧 6.8] Replacement of the accelerator and adjustment of the carburettor

Tightening torques

5	Screw for pulley	45 ÷ 50 Nm
-	Screws for engine fastening	25 ÷ 30 Nm

Map of functional units

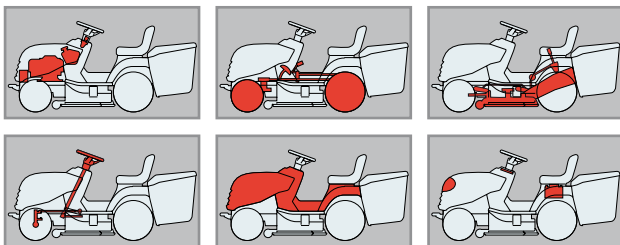

🔧 Remove the front hood.

For greater operating convenience it is recommended that the transmission belt is slacked off; this is done by engaging the parking brake.

⚠️ **FIRST** disconnect the black earth cable from the battery, and **THEN** the red cable, to prevent possible short circuits and dangerous situations.

Free the blade belt (1) from the clutch pulley (2).

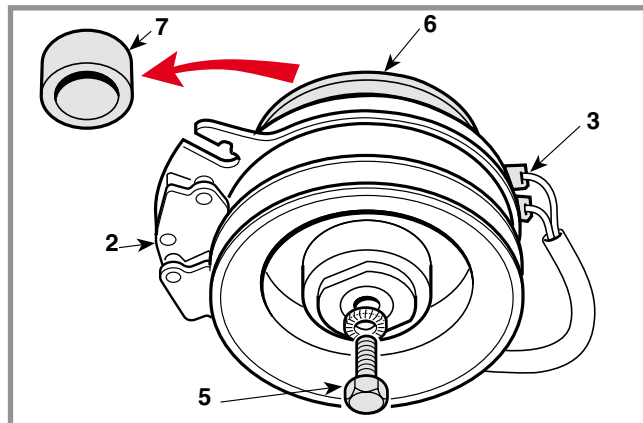
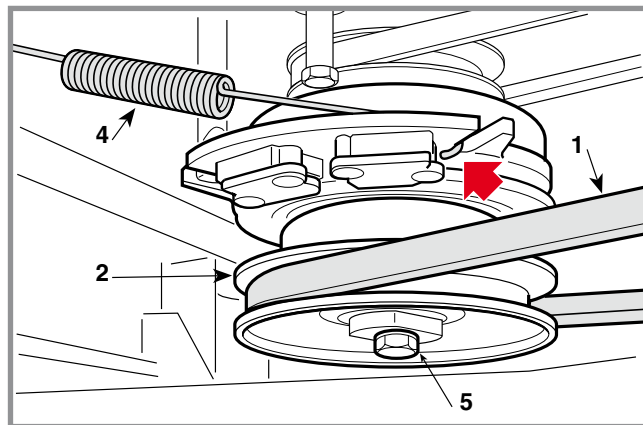

Disconnect the connectors (3) from the clutch contacts (2), unhook the return spring (4) from the clutch side and unscrew the central screw (5) with the help of a power screwdriver.

Remove the clutch (2) from the engine shaft, together with the transmission command pulley (6) and the spacer (7 - if installed).

IMPORTANT To remove the clutch (2) from the engine shaft, absolutely do not use a lever to force the pulleys or the outer cover. In case of difficulty, apply an unlocking spray and gently tap on the hub with a hammer, to facilitate extraction.

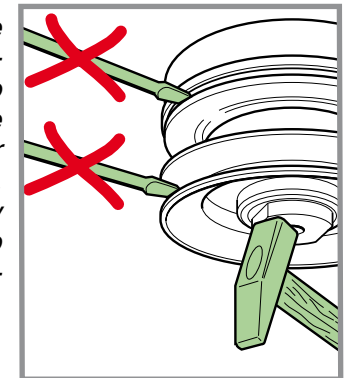

Remove the exhaust guard (8).

Disconnect the accelerator cable control and the electrical cables.

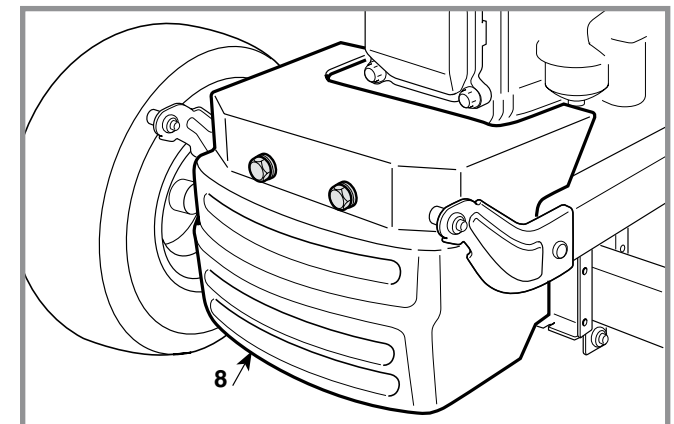

REMOVAL OF THE ENGINE

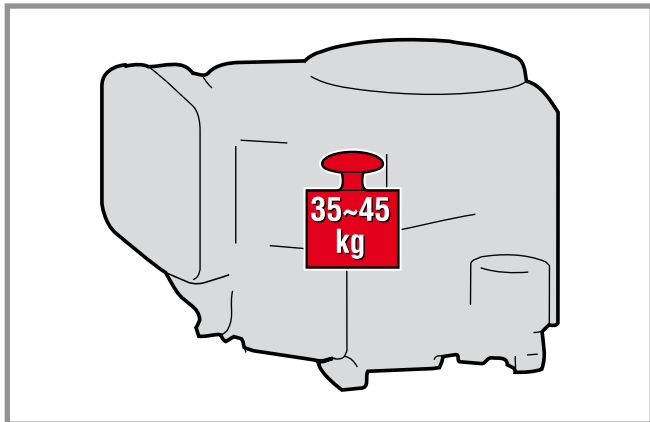

! Detach the fuel line pipe, taking care not to spill fuel.

! Identify and undo all the screws that fasten the engine to the chassis, then carefully lift and remove the engine using equipment suitable for the weight of the engine (about 35-45 kg) and the designated lifting points to guarantee safe working conditions.

NOTE Some engines are held with screws of different length and in different positions, so it is best to label them so that no errors are made on reassembly.

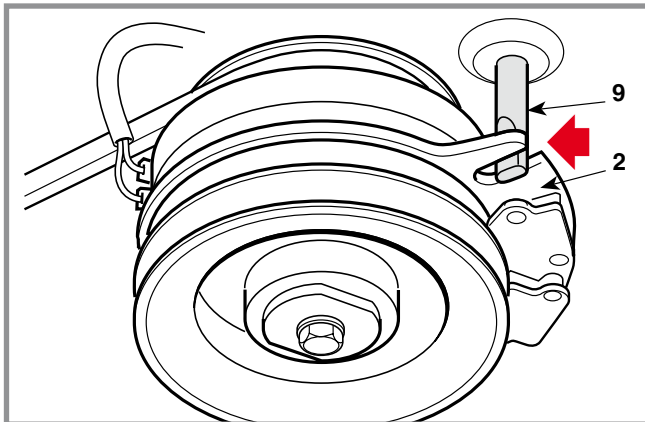
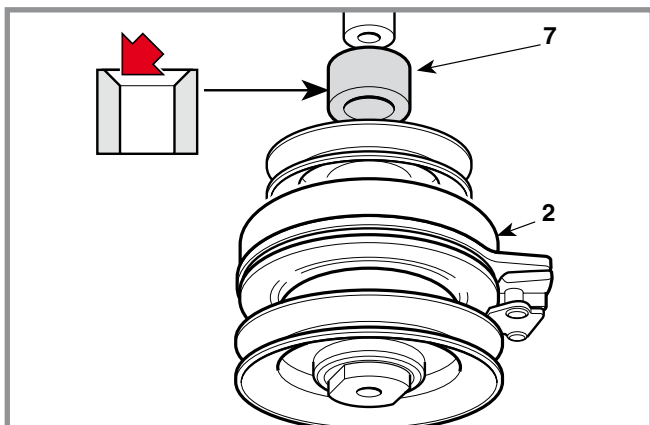

For reassembly follow the operations described above in reverse.

If the spacer (7) is installed, it must be fitted with the counter-sinking hole facing the engine.

Ensure that the pin (9) is inserted in the groove in the clutch (2) and remember to replace the spring (4).

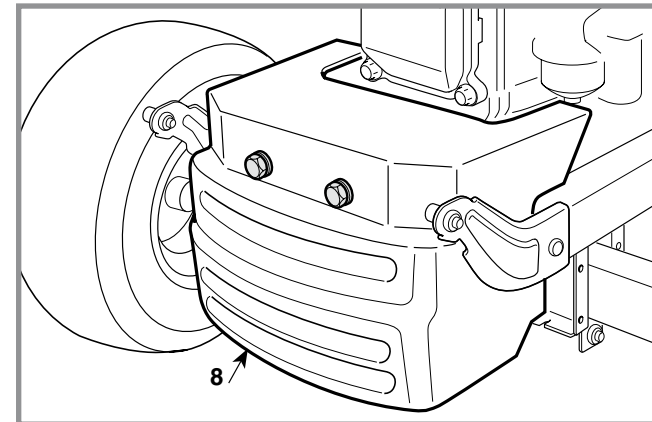
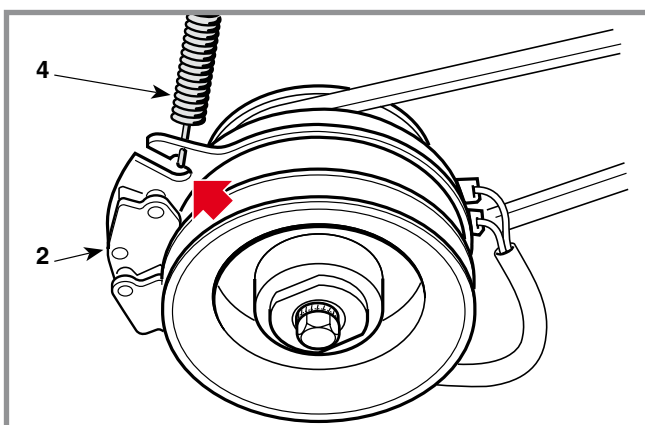

Fully tighten the engine and pulley fixing screws to the prescribed values.

! Remember to fit the clamps back on the fuel pipe and check that it does not leak.

Carefully restore all electric and earth contacts and always refit the exhaust guard (8).

Reattach the accelerator cable and ...

☛ Adjust the «MINIMUM» position.

☛ Refit the front hood.

REMOVAL OF THE REAR AXLE
Peerless MST 205-535 E

CHAPTER	REVISION	FROM ...	PAGE
5.6	1	2018	1 of 2

General informations

The rear axle (Transaxle) is made up of a single maintenance free sealed unit which includes the transmission unit (mechanical) and the differential and doesn't need any maintenance. It only needs to be removed to be replaced or for an overhaul by the Manufacturer's Service Centre.

Related topics

- [🔧 2.3] Lifting of the machine
- [🔧 4.2] Brake adjustment
- [🔧 5.6] Removing the ejection conveyor
- [🔧 6.1] Removal of the wheels

Tightening torques

14	Screw for bracket fastening	25 ÷ 30 Nm
15	Self-tapping screw	25 ÷ 30 Nm
17	Rear axle fastening nut	25 ÷ 30 Nm

Map of functional units

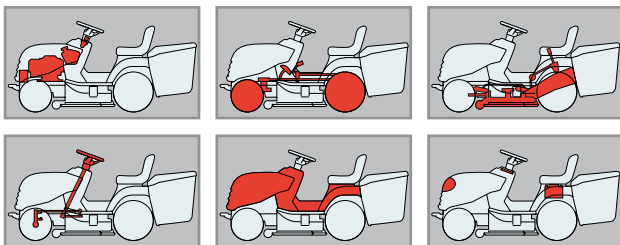

- 🔧 Remove the rear of the conveyor.
- 🔧 Lift the rear part of the machine
- 🔧 Remove the rear wheels.

Engage the parking brake to slacken off the belt and obtain greater operating convenience.

Bring the cutting deck to the highest position.

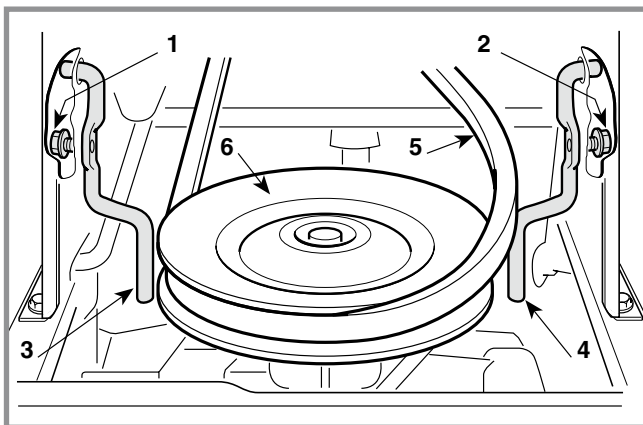

Loosen the two side screws (1) and (2) and move the two belt guides (3) and (4) forward until the belt (5) is released from the pulley (6).

Remove the split pin (7) and disconnect the gear control rod (8).

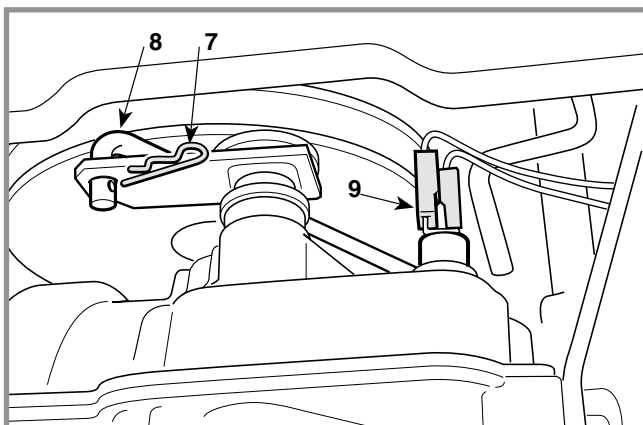

Disconnect the "neutral" signal microswitch cables (9).

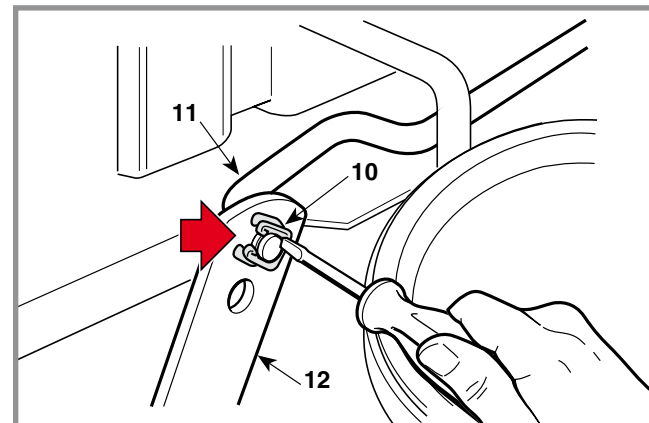

Release the parking brake to reduce spring tension on the rod, then remove the plate (10) and disconnect the brake control rod (11) from the lever (12).

The unit is supported on the left by a bracket (13) with their screws (14) and (15) and is attached to the frame by four screws (16) with their nuts (17).

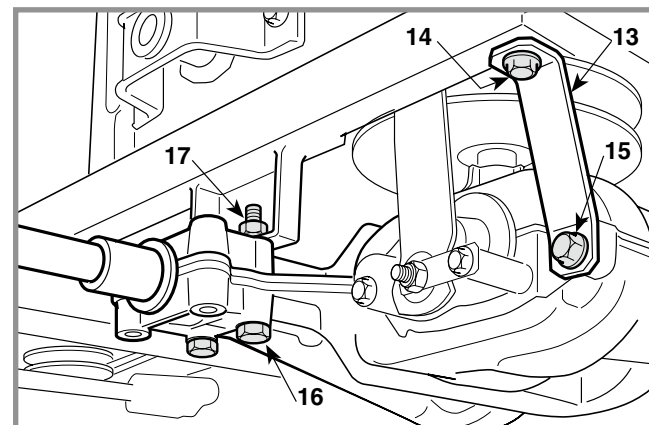

REMOVAL OF THE REAR AXLE

Peerless MST 205-535 E

CHAPTER	REVISION	FROM ...	PAGE
5.6	1	2018	2 of 2

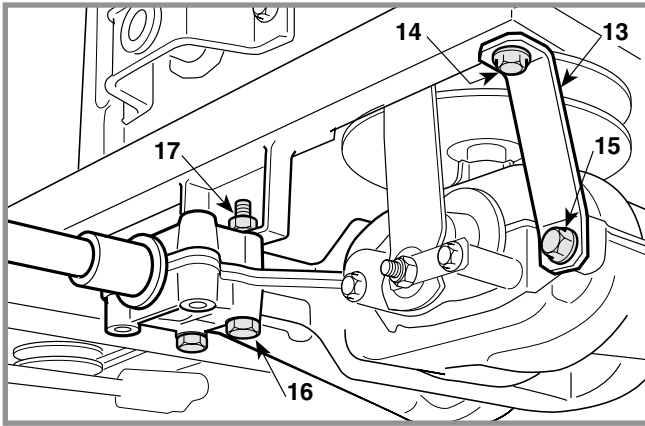

Loosen the screw (14) to give a minimum of movement to the bracket (13) and undo the two screws (16). Then carefully loosen the four nuts (17), holding up the unit so that it does not fall.

To reassemble, reverse the order of the previous operations, taking particular care with the self-tapping screw (15) which, if not screwed in correctly, could damage the threads inside so preventing it from being fastened properly.

When connecting the rod (11) be sure to use the uppermost hole in the lever (12) and replace the washer (18).

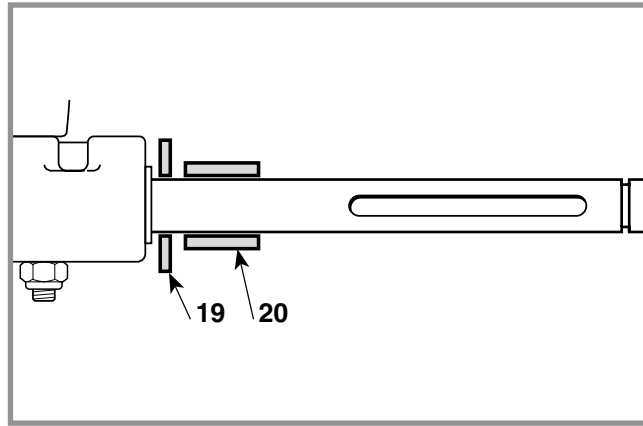
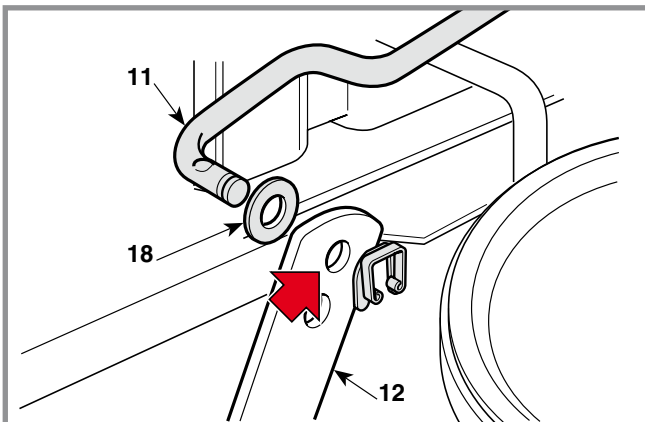

Check that the spacers (19 - 20) are correctly fitted to the shafts, in the sequence given.

Reattach all the connections, and then ...

- ☛ Refit the rear wheels.
- ☛ Reassemble the rear of the conveyor.
- ☛ Check the brake.

General informations

The rear axle (Transaxle) is made up of a single maintenance free sealed unit which includes the transmission unit (hydrostatic) and the differential and doesn't need any maintenance. It only needs to be removed to be replaced or for an overhaul by the Manufacturer's Service Centre.

Related topics

- [🔧 2.3] Lifting of the machine
- [🔧 4.2] Brake adjustment
- [🔧 4.4] Drive pedal adjustment
- [🔧 5.8] Removing the ejection conveyor
- [🔧 6.1] Removal of the wheels

Tightening torques

2 Fan fastening nut	45 ÷ 55 Nm
9-10 Nuts for bracket fastening	25 ÷ 30 Nm
11 Rear axle fastening nut	25 ÷ 30 Nm

Map of functional units

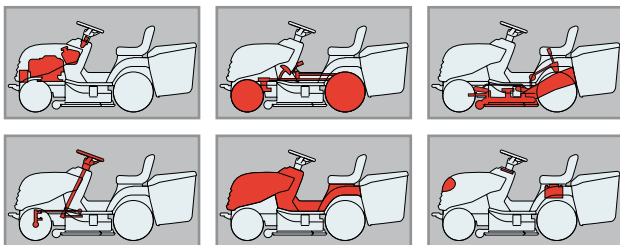

- 🔧 Remove the rear of the conveyor.
- 🔧 Lift the rear part of the machine
- 🔧 Remove the rear wheels.

Engage the parking brake to slacken off the belt and obtain greater operating convenience.

Unscrew the nut (2) using an impact driver and remove the fan (2a) so as to free the belt (1) from the pulley (2b). Alternatively, unscrew the engine pulley so that the belt remains loose.

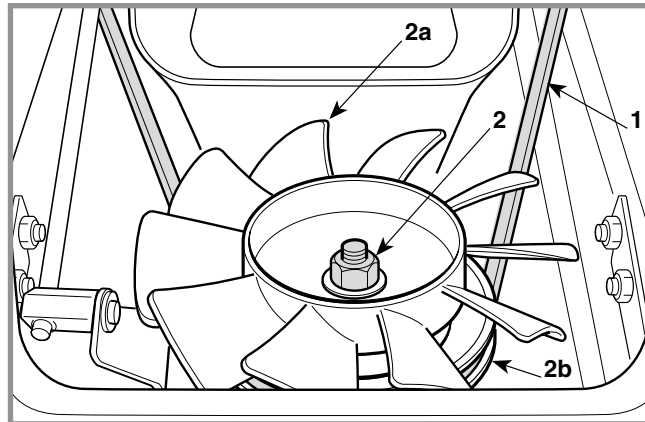

Remove the snap ring (3) and disconnect the drive control lever (4).

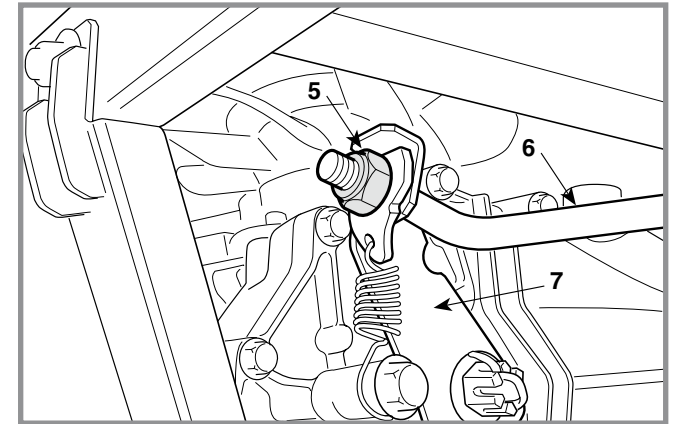
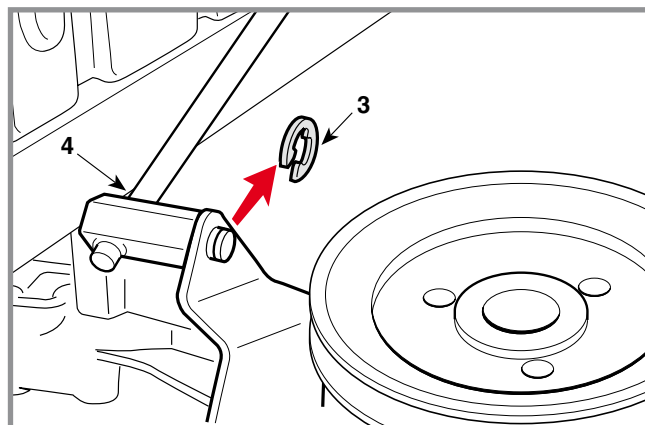

Release the parking brake to reduce spring tension on the rod, then remove the nut (5) and disconnect the brake control rod (6) from the lever (7).

The unit is supported by a bracket (8) from the rear right hand side.

Loosen the upper nut (9) to give a minimum of movement to the bracket (9), unscrew the nut (10) and slide out the relative screw.

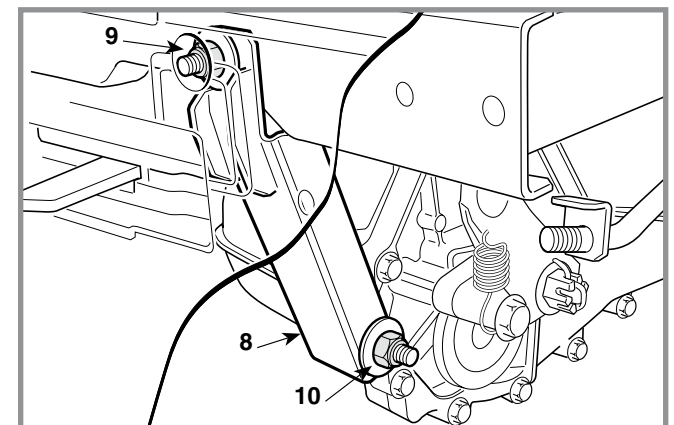

REMOVAL OF THE REAR AXLE
Hydro-Gear T2-ADBF-2X3C-1RX1

CHAPTER	REVISION	FROM ...	PAGE
5.6a	0	2018	2 of 2

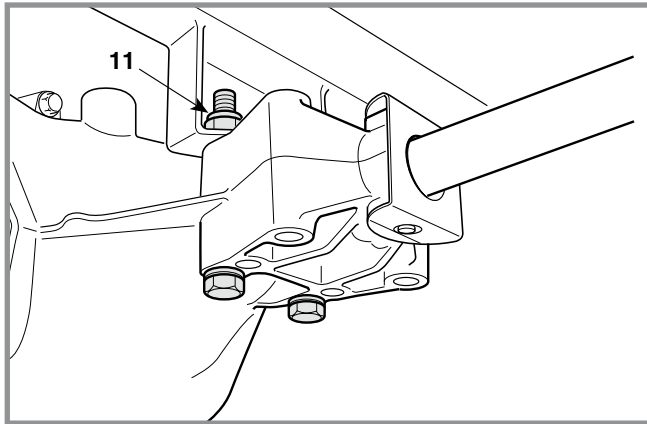

Carefully unscrew the four frame fastener nuts (11), adequately supporting the unit so it does not fall.

To reassemble, reverse the order of the previous operations.

If the fan (2a) was removed, ensure the shaped washer (2c) is replaced below the nut (2).

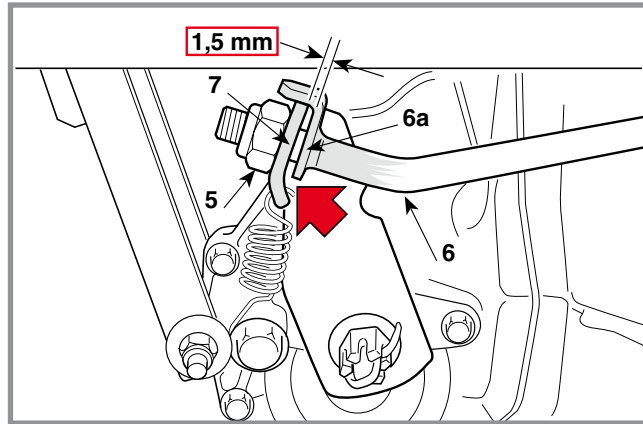
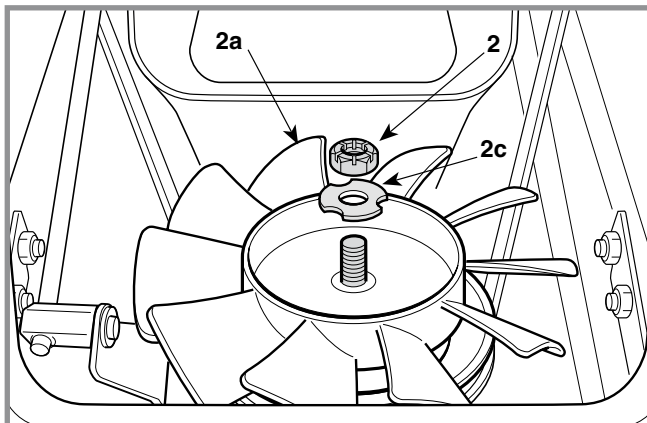

When you come to connect the brake rod (6), it is necessary to screw the nut (5) on as far as possible, along the entire rod thread.

After completing the screwing phase, engage the parking brake and check that there is a 1.5 mm gap between the rod plate (6a) and the lever (7).

Check that the spacers (12 - 13) are correctly fitted to the shafts, in the sequence given.

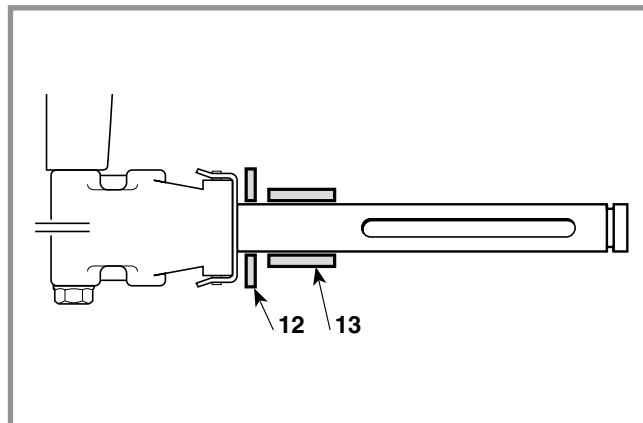

Reattach all the connections, and then ...

- ☛ Refit the rear wheels.
- ☛ Reassemble the rear of the conveyor.
- ☛ Check the brake.

If the the drive control rod has been replaced or completely pulled down:

- ☛ Adjust the travel and the position of “neutral” for the pedal

REMOVAL OF THE CUTTING DECK

General informations

Removing the cutting deck facilitates all the overhaul and replacement of hubs, bearings and blade shafts.

With some practice and experience it is possible to do this work with the deck still in position.

Related topics

 [4.5](#) Aligning the cutting deck

 [5.8](#) Removing the ejection conveyor

Tightening torques

3 Steering rod fixing nut 18 ÷ 20 Nm

Map of functional units

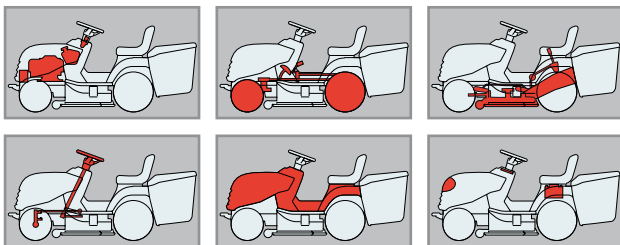

 Remove the collector channel

Free the blade belt (1) from the clutch pulley (2) and set the cutting height adjustment lever to position «1».

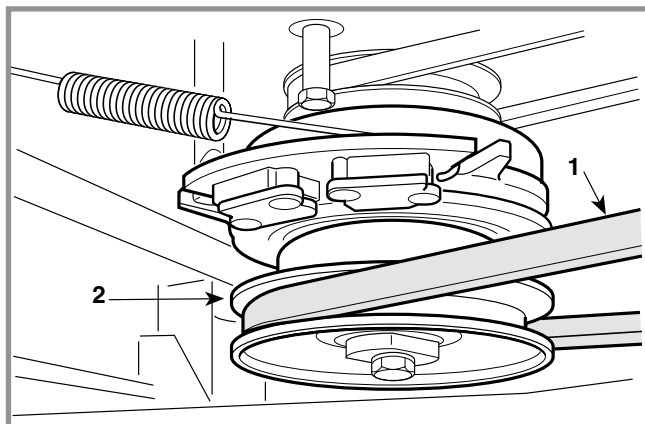

Unscrew the two nuts (3) fastening the two arms (4) to the frame.

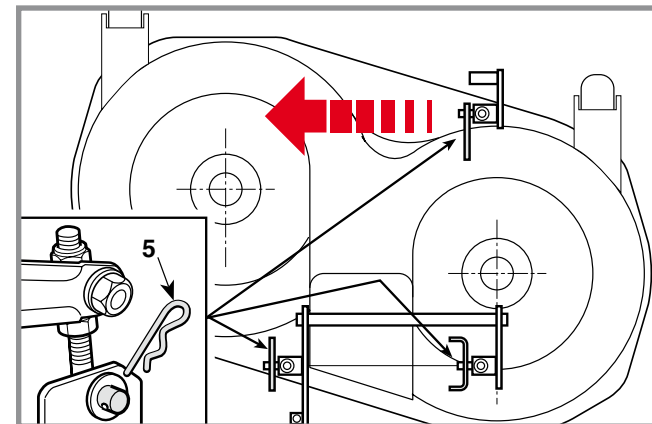
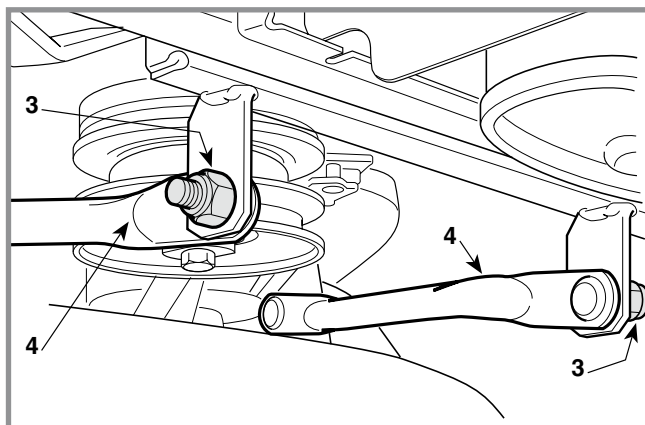

Release the three flexible split pins (5) of the lifting tie-rods.

Having checked that there is nothing in the way, the deck can be removed, turning it anti-clockwise so that all the pins come out of their positions.

To assemble, perform the operations described above in reverse order making sure to tighten the nuts (3) so as not to hinder correct cutting deck oscillation.

When assembly is completed ...

 Check the alignment of the cutting deck

REMOVAL OF THE DISCHARGE CONVEYOR

CHAPTER	REVISION	FROM ...	PAGE
5.8	0	2018	1 of 1

General informations

The removal of the front part of the conveyor makes the small side wheels and the transmission belt accessible.

The removal of the conveyor's rear part is necessary to disassemble the cutting deck and in case the rear plate is removed.

Related topics

[🔧 5.7] Removal of the cutting deck

[🔧 6.1] Removal of the wheels

Tightening torques

11 Screws for front discharge conveyor 8 - 10 Nm

Map of functional units

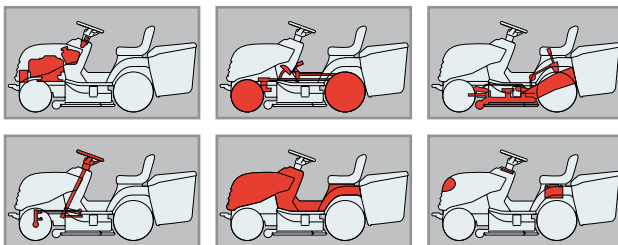

A) Rear

The conveyor (1) is connected to the rear plate (2) by two plastic clamps (3), removable with the help of a screwdriver.

On assembly, ensure the free vibration of the conveyor at each plate height variation.

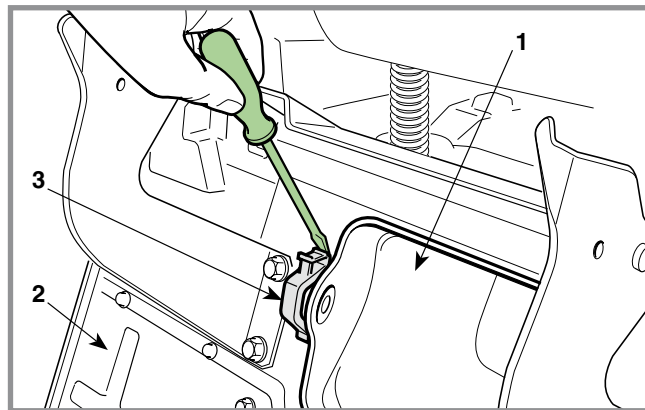

B) Front

- 🔧 Remove the cutting deck.
- 🔧 Remove the rear wheels.

Loosen the two nuts (11).

Remove the screws (12) and the spacers (13), operating from inside the outlet, and remove the front part of the conveyor (14).

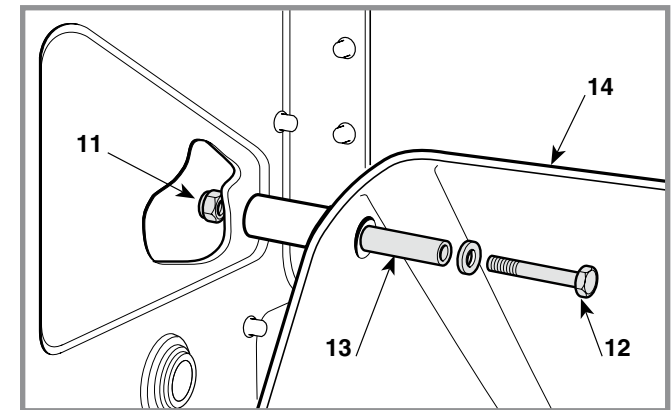

On assembly, ensure the free vibration of the conveyor at each plate height variation.

- 🔧 Refit the rear wheels.
- 🔧 Reassemble the cutting deck.

REPLACEMENT OF TYRES AND WHEELS

CHAPTER	REVISION	FROM ...	PAGE
6.1	0	2018	1 of 1

General informations

The tyres used are of the "Tubeless" type and so every repair of a hole in the tyre must be done by a tyre specialist according to the methods used for this type of tyre.

Related topics

[🔧 2.3] Lifting of the machine

[🔧 4.5] Aligning the cutting deck

Tyre pressures

Front	(Tyres 13 x 5.00-6)	1,5 Bar
.....	(Tyres 15 x 5.00-6)	1,0 Bar
Rear		1,2 Bar

Map of functional units

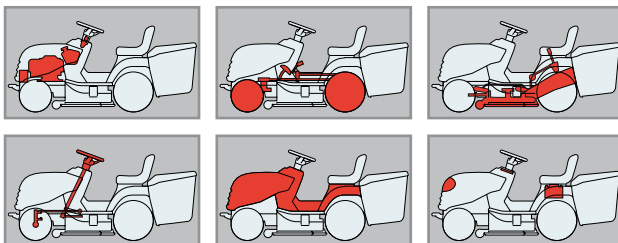

A) Tyres

After replacing one or more tyres or the wheels, it is always necessary to check the pressure and to check the alignment of the cutting deck.

⚠ WARNING! Replace distorted wheel rims as they could impair the tyre's hold.

B) Wheels

The wheels are held by a snap ring (1) which can be removed with the help of a screwdriver.

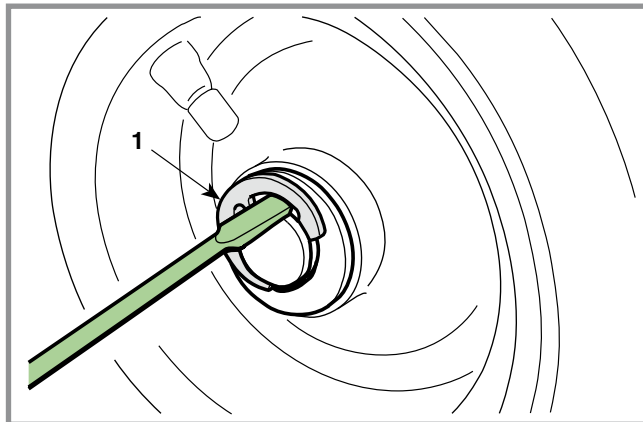

NOTE If a wheel is jammed onto the shaft, use a releasing spray, directing it around the splining hole.

On assembly it is advisable to spread grease on the shaft to facilitate the next wheel removal.

● **For the front wheels:** replace the shoulder washer (2) and the flexible ring (1) with the bevel facing inwards.

● **For the rear wheels:** replace the shoulder washer (2) and the flexible ring (1) with the bevel facing inwards and check the axial gap of the wheel on the shaft; if it is greater than 3 mm, a spacer (3) must be fitted between the wheel hub and the shoulder washer (2).

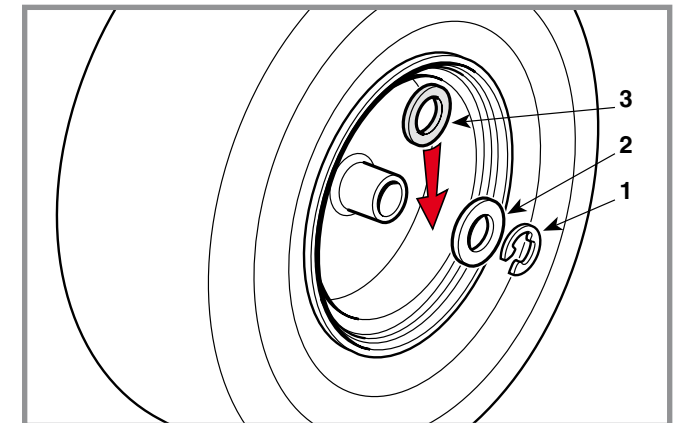

General informations

Related topics

[🔧 2.2] Tools

[🔧 2.3] Lifting of the machine

[🔧 6.1] Replacement of tyres and wheels

Map of functional units

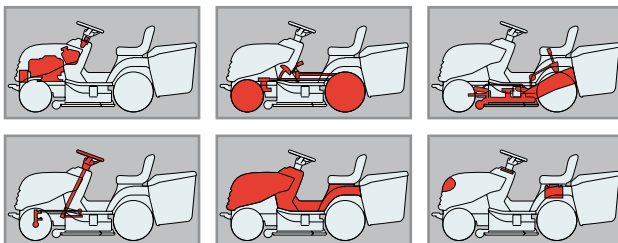

🔧 Dismantle the front wheel.

The front wheel bearings (1) are force splined into the front wheel hub.

A 10 - 12 mm diameter round bar (2) must be used to extract a bearing, inserted from the opposite side and struck with a hammer around various points of the inner circumference of the bearing.

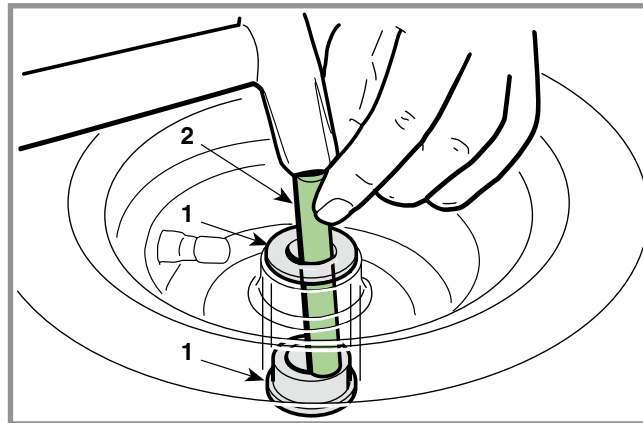

The new bearing must be fitted with the help of a plastic mallet or of a bronze pad (3) that only acts on the bearing's outer ring.

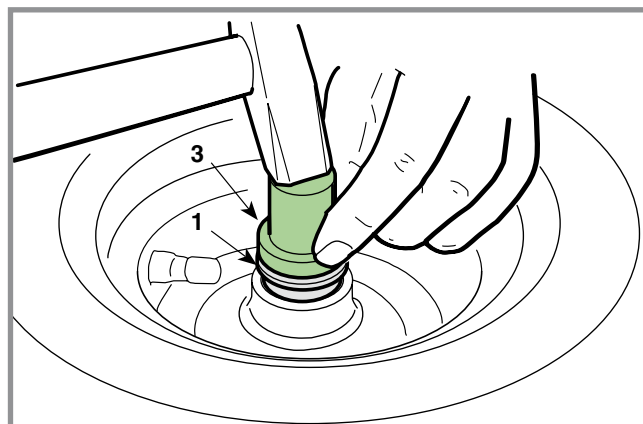

General informations

Related topics

[\[4,7\]](#) Steering geometry adjustment

Tightening torques

6 Steering tie-rod fastening nut 45 ÷ 50 Nm

18-19 Pin fastening nuts 25 ÷ 30 Nm

Map of functional units

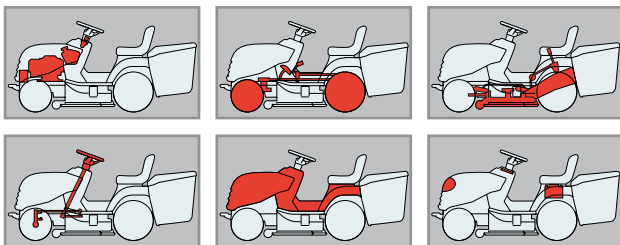

Remove the inspection hatch (1)..

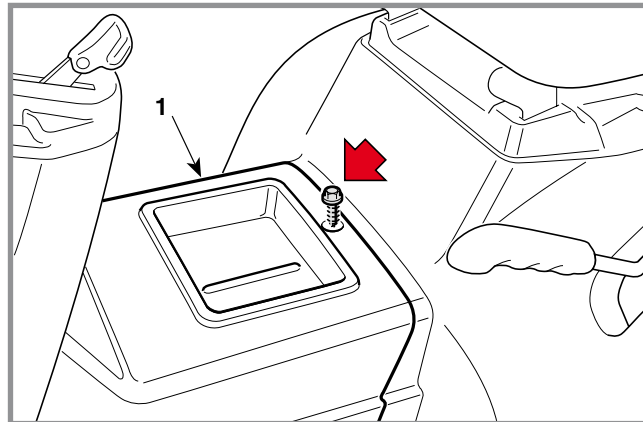

A) Dismantling the steering pinion and ring gear

Unhook the spring (2) and lift the steering column (3) just enough to be able to draw out the pinion (4), taking care not to take out the pin (5).

Unscrew the nut (6) and disconnect the steering tie-rod (7).

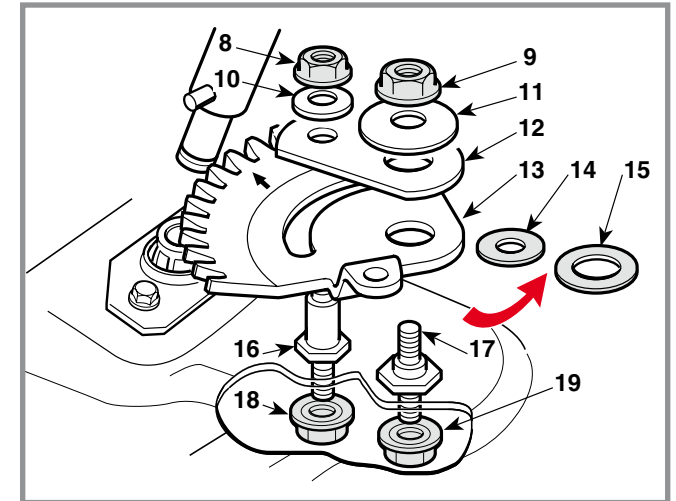
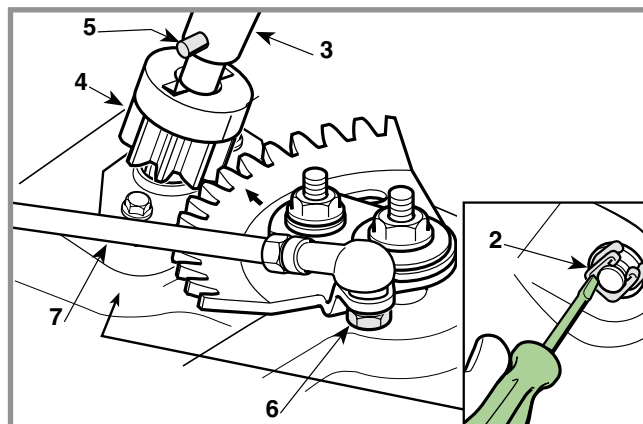

Remove the nuts (8) and (9), the cup washer (10) and (11), the guide (12) and dismantle the ring gear (13).

In the case of replacement of the ring gear and pinion, the blocks (14) and (15), that might have been placed under the ring gear previously, must be removed.

Check pin (16) and (17) wear and, if necessary replace them by unscrewing the relevant nuts (18) and (19).

To assemble, perform the operations described above in reverse order being careful to correctly reconnect the pin (5) in the pinion housing (4).

When replacing the pins (16) and (17), tighten the relevant nuts (18) and (19) to the recommended value.

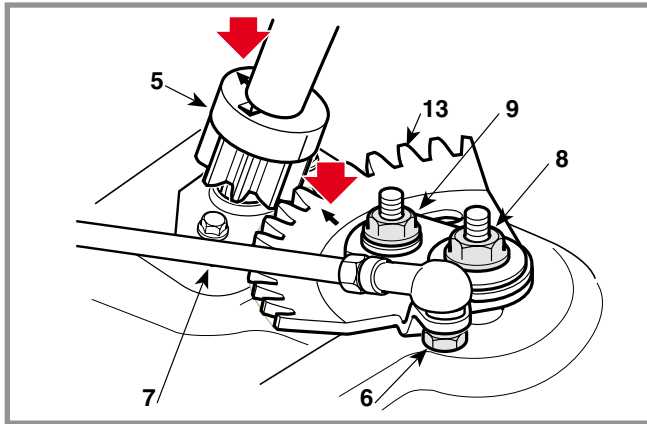

! Reassemble the ring gear matching the two references ($\Rightarrow \triangleleft$), punched on the ring gear (13) with the pinion (5) in the drive direction.

Reassemble the nuts (8) and (9), tightening them to load the cup springs (10) and (11) as much as need to ensure steering manageability, without creating excessive play.

Refit the steering tie-rod (7) and tighten the nut (6) to the prescribed value.

B) Lower bush replacement

Unhook the spring (21) and lift the steering column (22) just enough to be able to draw out the pinion (23), taking care not to take out the pin (24).

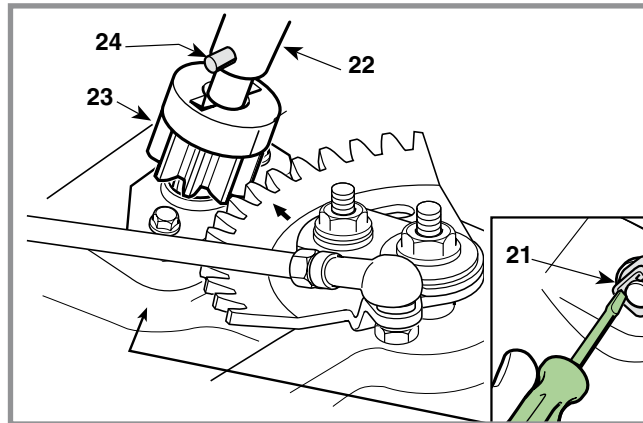

Use a universal socket wrench to unscrew the two screws (25) that fix the plate (26) and remove the spherical lower bush (27).

On reassembly ensure that the bush (27) is fitted with the protuberant part upwards.

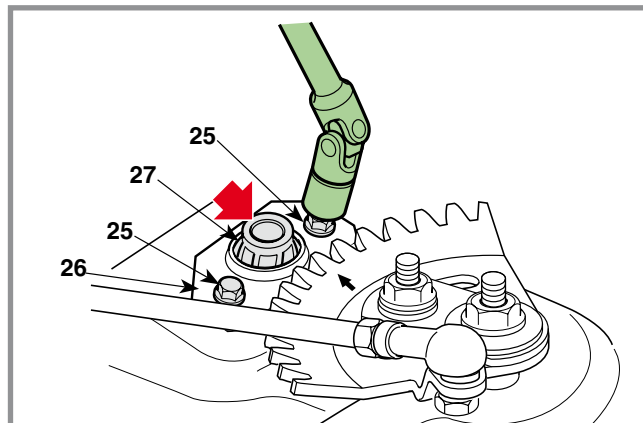

Refit the plate (26) without tightening the screws (25).

Correctly reposition the pin (24) in the pinion housing (23) and align the pinion to the ring gear.

Insert the end of the steering column (22) in the hole in the spherical bush (27); fully tighten the screws (25) after having checked the correct alignment and regular rotation of the steering column.

👉 Check the steering geometry

REPLACEMENT OF THE DRIVE BELT

General informations

Related topics

- [🔧 4.3] Drive belt adjustment
- [🔧 5.3] Removing the ejection conveyor
- [🔧 5.5] Removal of the engine
- [🔧 5.7] Removing the cutting deck
- [🔧 5.8] Removing the ejection conveyor
- [🔧 6.9] Replacement of the lifting cable
- [🔧 8.2] Belts assembly

Tightening torques

7 Drive pulley fastening nut	25 ÷ 30 Nm
9 Nut for pulley of the guide pulley	25 ÷ 30 Nm
11 Nuts for small wheels	25 ÷ 30 Nm

Map of functional units

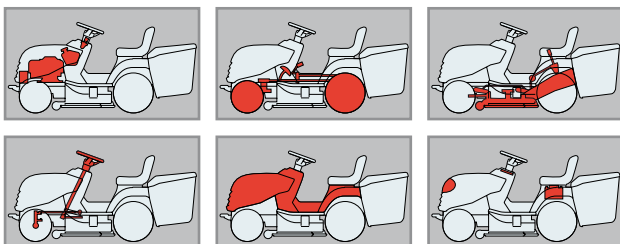

- 🔧 Remove the rear of the conveyor.
- 🔧 Removing the cutting deck.
- 🔧 Remove the wire of the deck lifting lever.
- 🔧 Remove the engine pulley and the clutch

Engage the parking brake to slacken off the belt and obtain greater operating convenience.

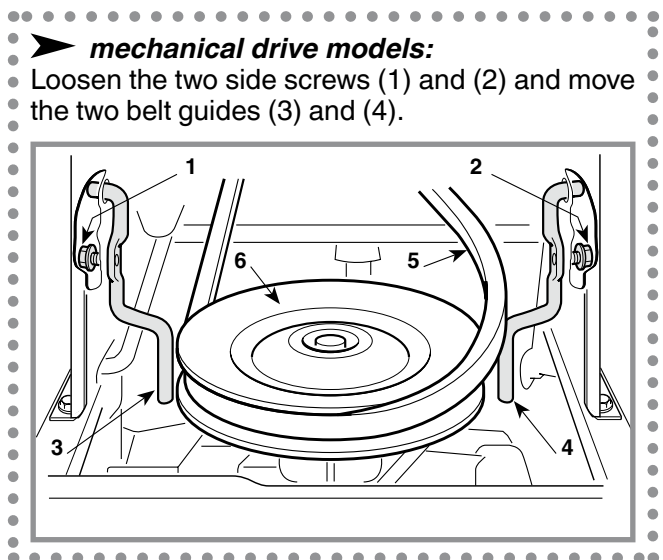

Hold the two parts of the belt (5) to release it from the pulley (6).

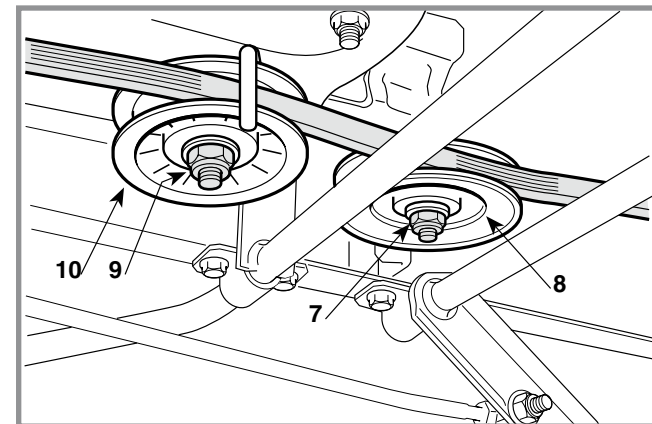
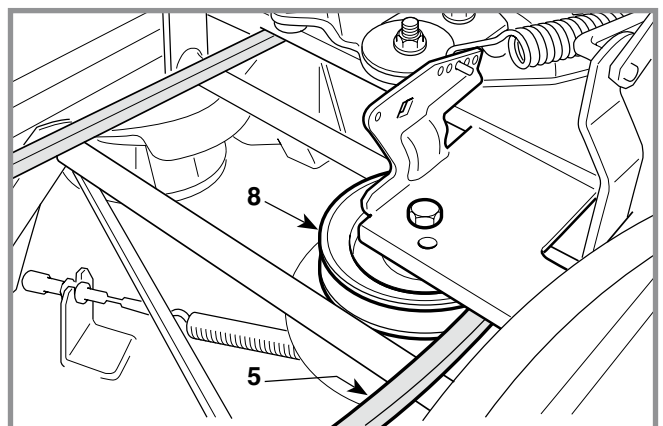

Loosen the nut (7) for the drive pulley (8) to the point where the passage of the belt is allowed (5).

Unscrew the nut (9) and take off the pulley of the guide pulley (10).

Unscrew the nuts (11), remove the two small wheels (12) and remove the belt (5).

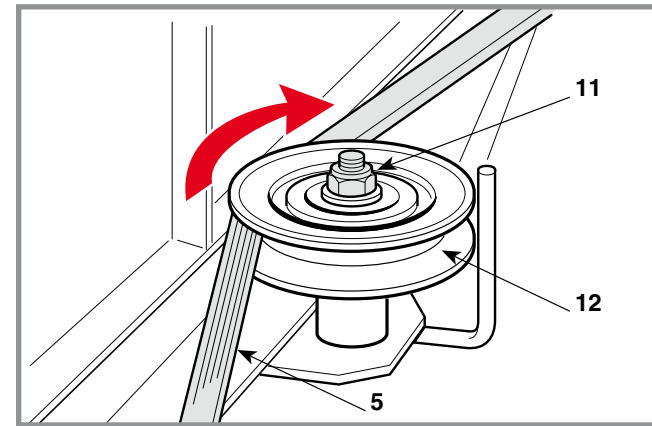

REPLACEMENT OF THE DRIVE BELT

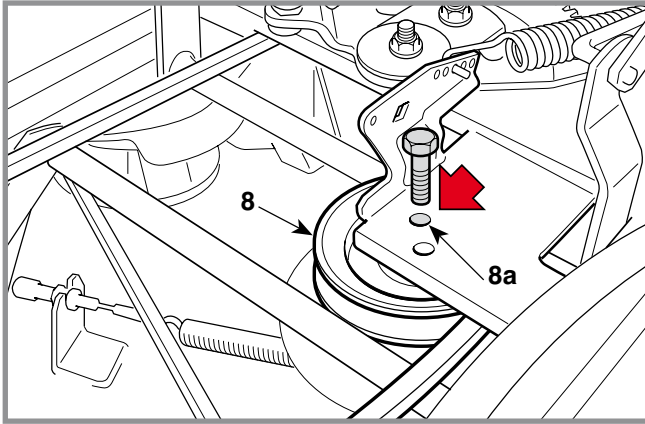

On assembly, follow the procedures described above in reverse order.

If previously removed, reassemble the pulley (8) using the hole (8a) available on the plate.

When assembly is completed, ...

- ☛ Refit the engine pulley and the clutch.
- ☛ Adjust the drive engagement.
- ☛ Reassemble the wire of the deck lifting lever.
- ☛ Remounting the cutting deck.
- ☛ Reassemble the rear of the conveyor.

REPLACEMENT OF THE SMALL WHEELS FOR THE DRIVE BELT

CHAPTER	REVISION	FROM ...	PAGE
6.5	0	2018	1 of 1

General informations:

Related topics:

[🔧 4.3] Drive belt adjustment

Tightening torques

3 Nuts for small wheels 25 ÷ 30 Nm

Map of functional units

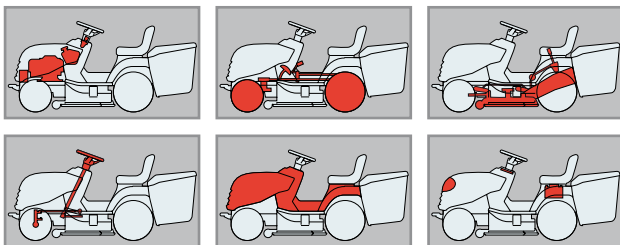

Bring the cutting deck to the lowest position «1».

Engage the parking brake to slacken off the belt and obtain greater operating convenience.

Remove the inspection hatch (1).

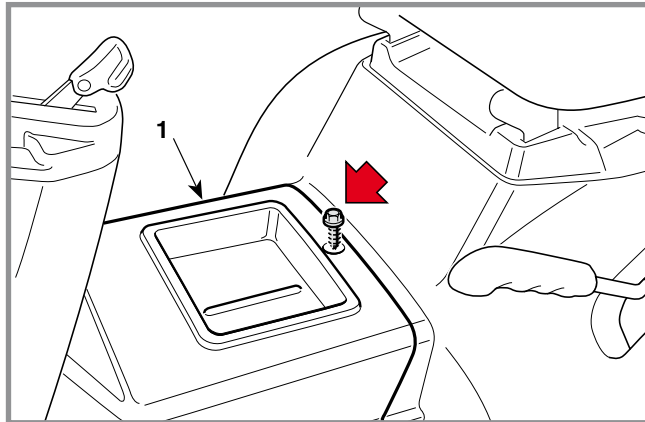

Unscrew the nuts (2) and remove the two small wheels (3) by moving them toward the rear of the machine.

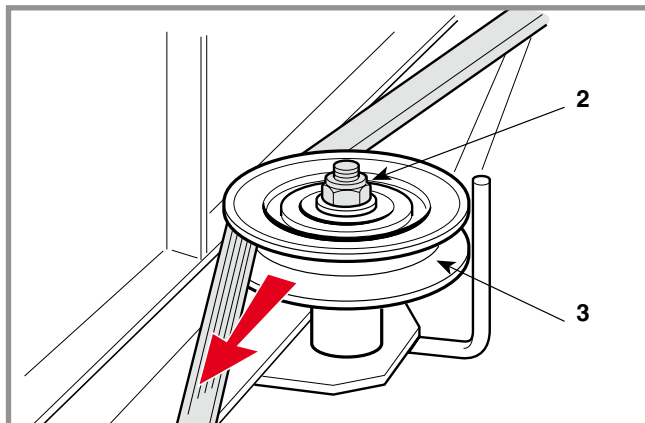

When assembly is completed, ...

🔧 Adjust the drive engagement.

General informations

Related topics

- [4.1](#) Adjusting the engagement and checking the blade brake
- [5.2](#) Removal of the side guards (if provided)
- [8.2](#) Belts assembly

Map of functional units

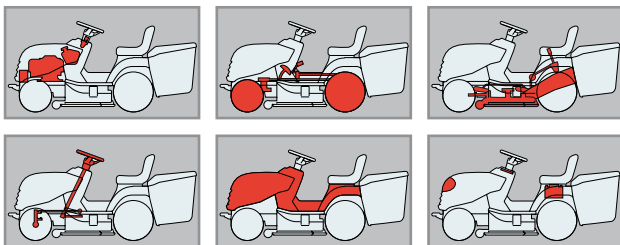

☛ Remove the left and right side guards (if provided).

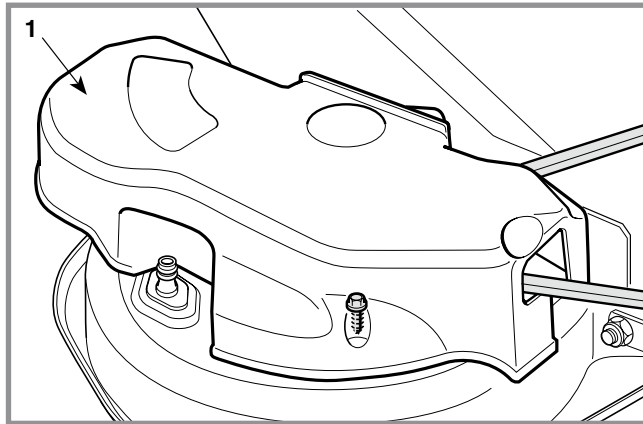

Remove the right (1) and left (2) guards.

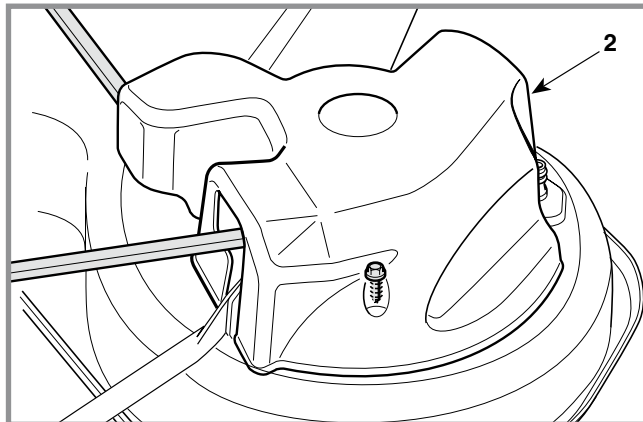

Free the blade belt (3) from the clutch pulley (4).

Loosen the screw (5) and remove the drive pulley (6).

At this point the tension regulator guide pulley (7) can be distanced manually and the belt (3) unthreaded and replaced.

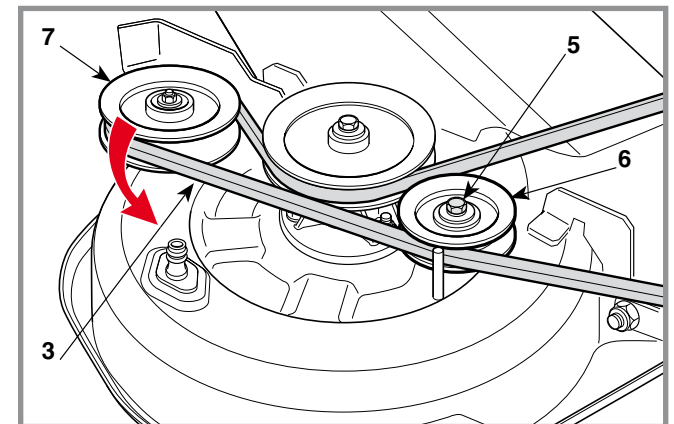
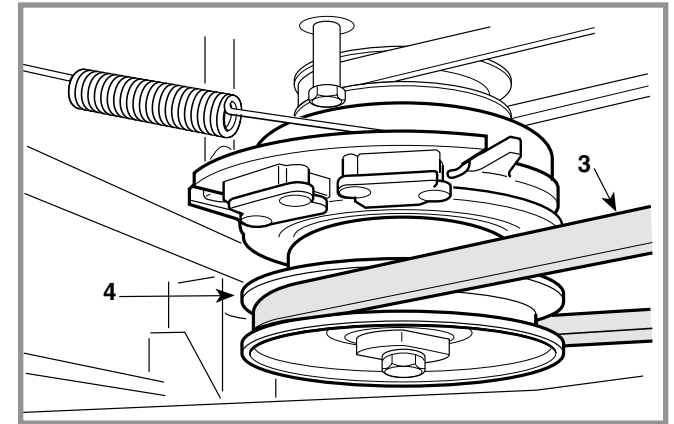

When reassembling the right (1) and left (2) guards, keep the belt (3) taut so that it is well-inserted in the pulley grooves and do not interfere with the belt guides inside the guards.

⚠ Always reassemble the side safety guards.

Once assembly is completed ...

☛ Adjust the blade engagement.

REPLACEMENT OF THE SUPPORTS AND SHAFTS OF THE BLADES

CHAPTER	REVISION	FROM ...	PAGE
6.7	1	2018	1 of 3

General informations

Related topics

[🔧 2.2] Special tools

[🔧 4.9] Removing, sharpening and balancing the blades

[🔧 5.2] Removal of the side guards (if provided)

[🔧 5.7] Removal of the cutting deck

Tightening torques

7 Screws for pulleys fastening 20 ÷ 25 Nm

10 Flanged support fixing nuts..... 25 ÷ 30 Nm

Map of functional units

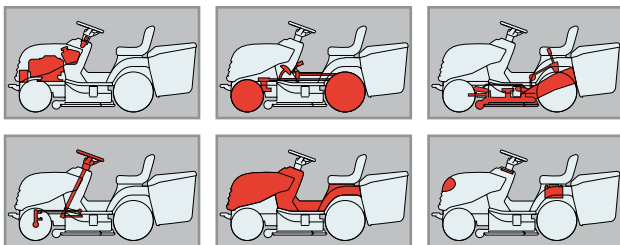

- 🔧 Remove the left and right side guards (if provided).
- 🔧 Remove the cutting deck.

NOTE *This operation is not strictly necessary since, with a little practice and experience, it is possible to dismantle the deck supports without removing the cutting deck.*

- 🔧 Remove the blades and take off the hub

Remove the right (1) and left (2) guards fixed by the relative screws and/or nuts.

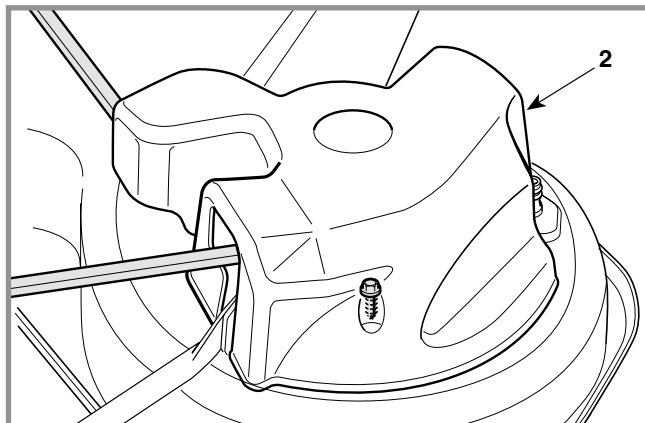
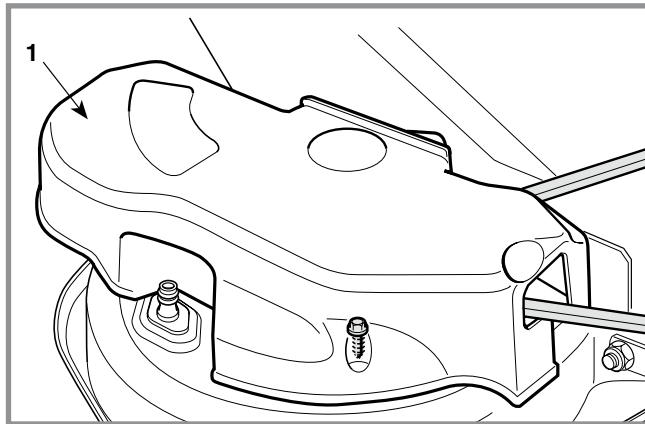

A) Replacement of the supports of the blades

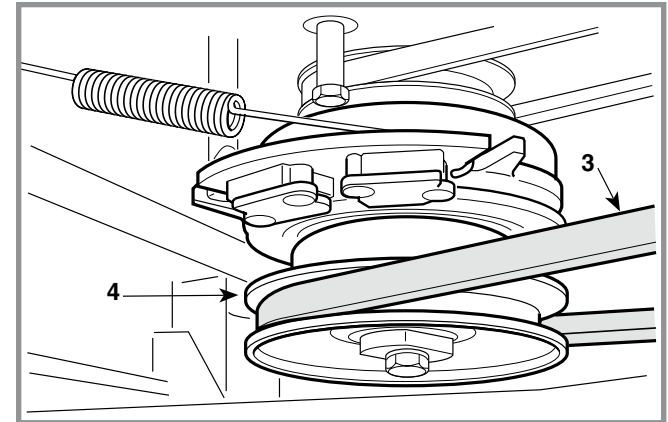

Free the blade belt (3) from the clutch pulley (4) and set the cutting height adjustment lever to position «1».

Unscrew the central screws (7) and unthread the pulleys (8).

NOTE - *The removal of pulleys may be facilitated by the use of the specific pulley extractor (19).*

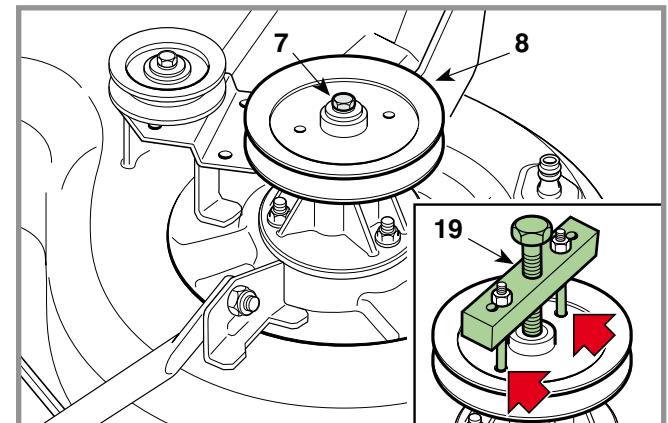

REPLACEMENT OF THE SUPPORTS AND SHAFTS OF THE BLADES

CHAPTER	REVISION	FROM ...	PAGE
6.7	1	2018	2 of 3

➤ **MP98 models:**

Disassemble the right bracket (21), fastened in place by the screw (22) and relative nut (23). Unscrew the nut (24), remove the belt tensioner unit (25) with the spacer (26) and remove the left bracket (27).

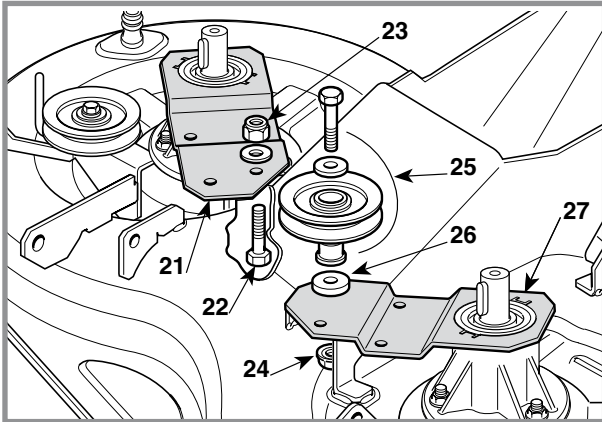

Dismantle the flange support (9) by unscrewing the three nuts (10).

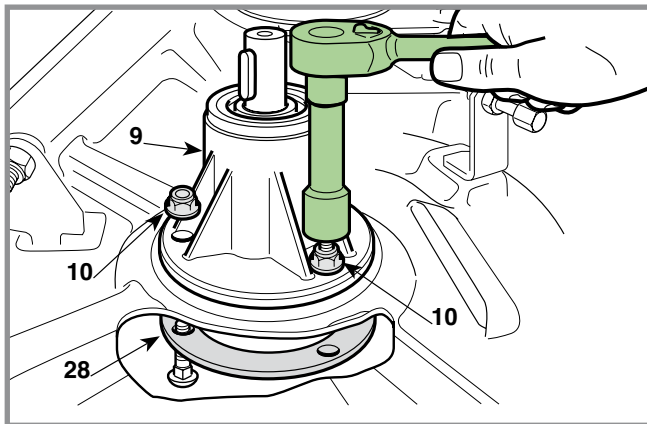

NOTE - The entire support (9), including shafts and bearings, is a spare part available as a single assembly unit.

Reassemble the supports (9) on the cutting deck, making sure you don't invert the right with the left.

➤ **MP98 models:**

- On reassembling, make sure that the spacer (26) is positioned correctly between the bracket (27) and the belt tensioner (25).
- Replace the plates (28) and tighten the nuts (10) to the prescribed torque values.

On completion of assembly of the supports, ...

- Reassemble the hubs and start sharpening, balancing and assembling the blades.
- Reassemble the cutting deck.

⚠ Always reassemble the side safety guards.

B) Replacement of the bearings and the shafts of the blades

Remove the key (11) and hit the shaft with a plastic mallet on the pulley side in order to remove the shaft together with the lower bearing (12).

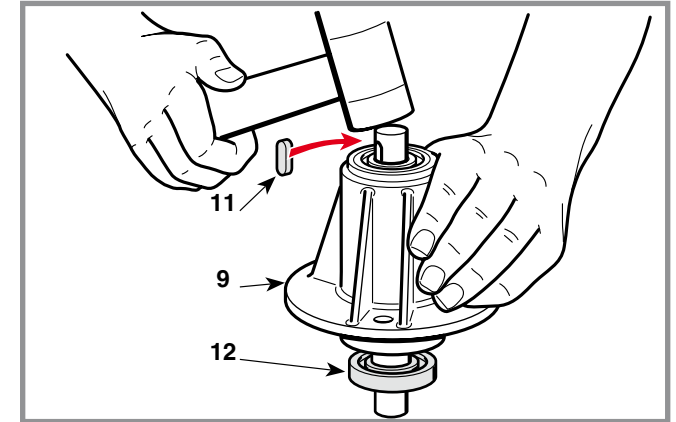

After having removed the snap ring (13), the dust cover (14) and the spline (15), the bearing (12) splined onto the shaft can be removed using a normal extractor, taking care to close up the threaded hole (16) with a screw to prevent the point of the extractor from damaging the thread.

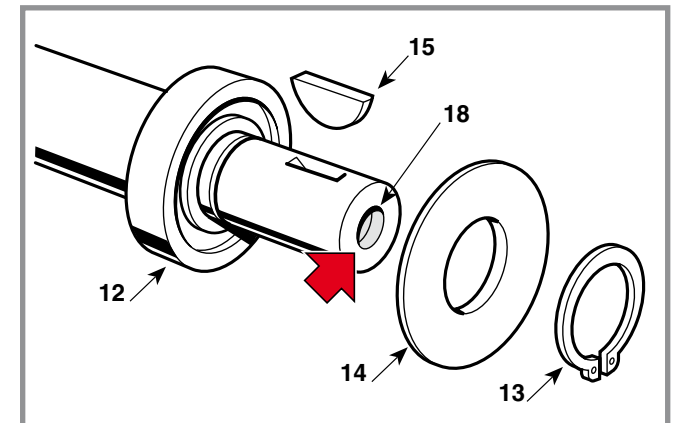

The second bearing still in place must be removed by hitting it from the inside of the flange using a 12 ÷ 15 mm diameter round bar (17).

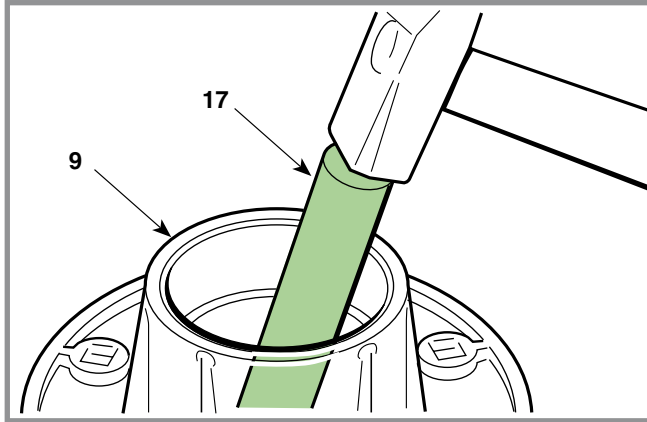

On reassembling, first put the shaft into the hole of the lower bearing and insert this into the support. Fit on the upper bearing and, using the special bush (18) which works on the inner ring, hit it squarely with a mallet until the bearing is fully driven home.

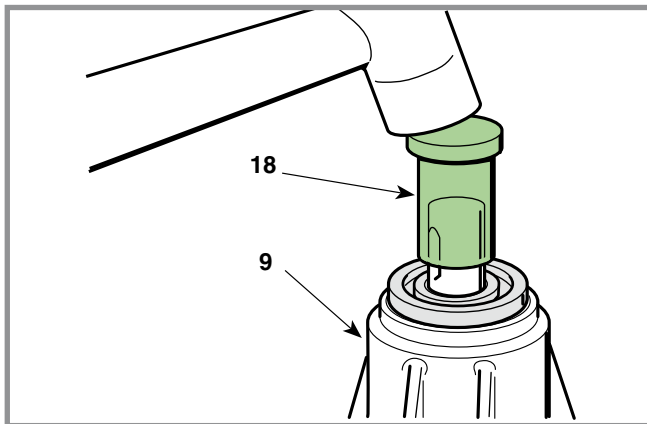

IMPORTANT *The right and left shafts seem to be the same, but can be differentiated as follows:*

- right shaft: red paint on the pulley side;
- left shaft: green paint on the pulley side.

Before refitting the support assembly, check that these positions are correct.

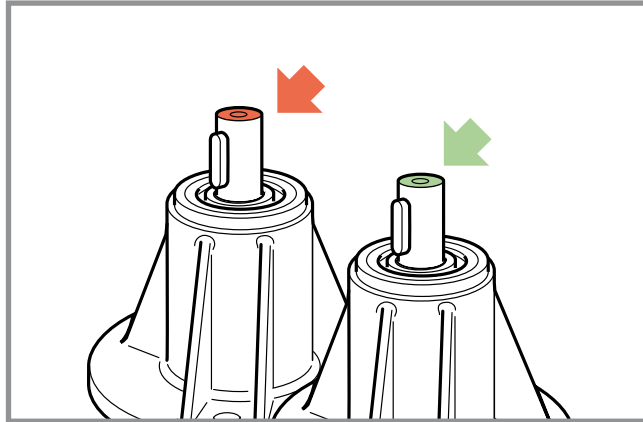

Fit the flange supports onto the deck, fully tightening the nuts (10).

General informations

Related topics

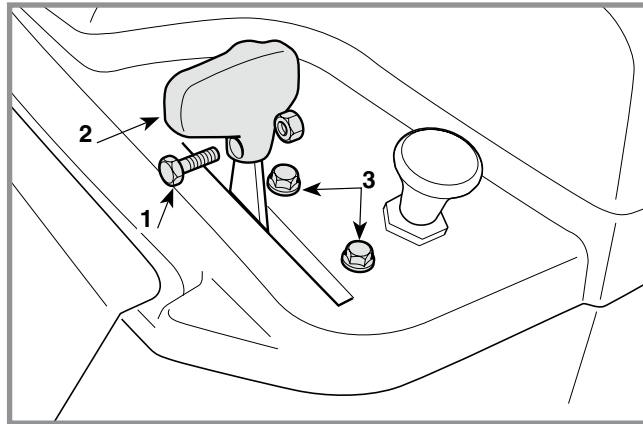

Unscrew the screw (1), take off the knob (2) and undo the two screws (3) which hold the accelerator on the dashboard.

From the motor side, loosen the terminal screw (4), disconnect the wire (6) terminal (5) from the slider (7) and remove the accelerator with the wire.

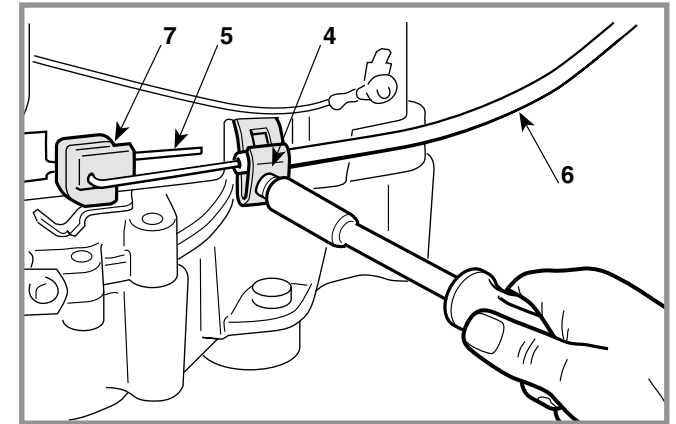

To assemble, put the accelerator lever in «MIN» and connect the wire (6) terminal (5) to the slider (7).

Move the slider (7) to the specific «MIN» position for each type of motor and indicated in the relevant instruction booklet. Then secure the wire (6) to the terminal (4).

Map of functional units

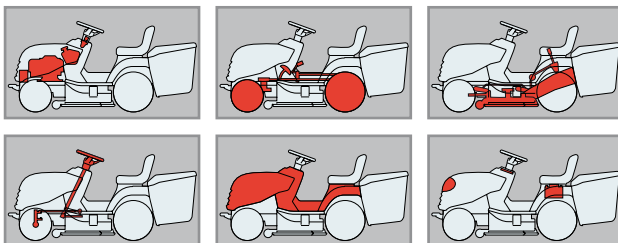

General informations:

Related topics:

[\[🔗 4.5\]](#) Aligning the cutting deck

Map of functional units

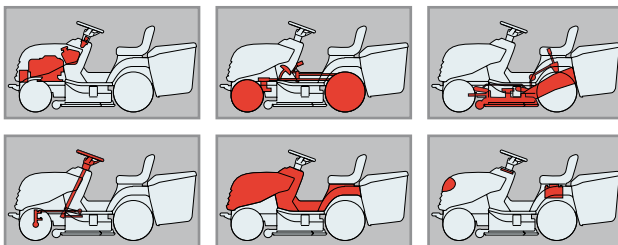

Put blocks beneath the cutting deck in line with the centre lines of the blades:

- at the front 26 mm (1)
- at the back 32 mm (2)

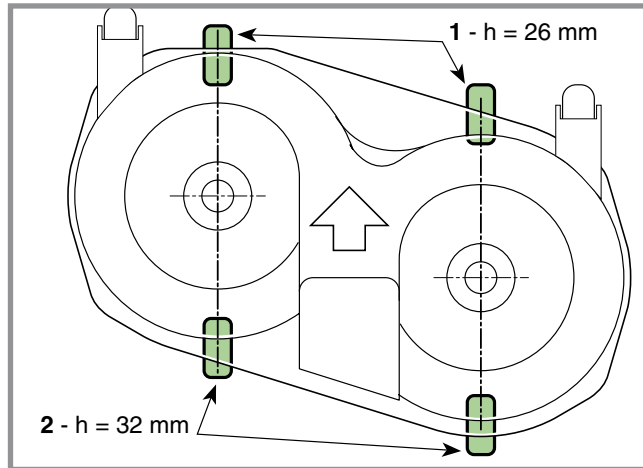

Put the height lever in position «1» and completely loosen the adjuster (3).

Loosen the screw (4) and remove the drive pulley (5) to slide out the cable (6).

Unhook the end (7) of the cable (6) from the control lever (8) and remove the cable.

To assemble, perform the operations described above in reverse order, making sure the cable (6) correctly passes through the slots (9) and (10).

After restoring adjuster tension (3), the cutting deck should return to the alignment conditions previous to cable replacement. If this is not the case...

🔧 Adjust the alignment of the deck.

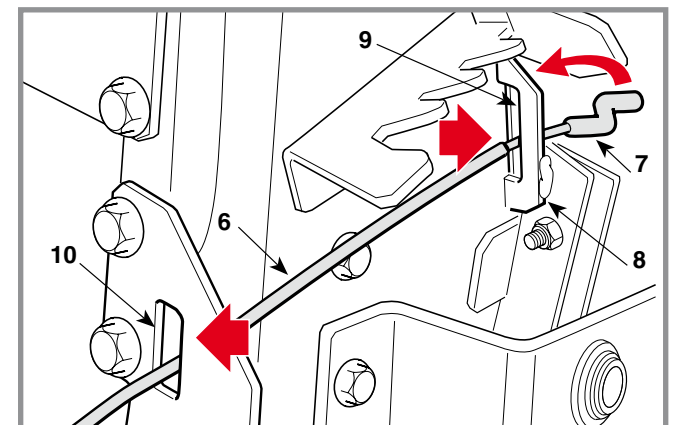
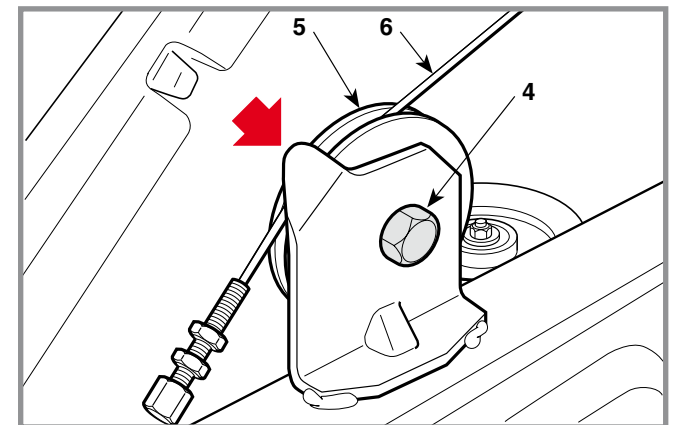
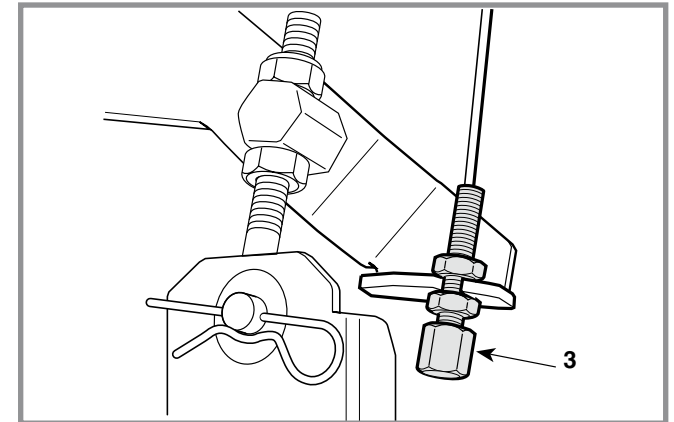

General informations:

Related topics

- [🔧 2.3] Lifting of the machine
- [🔧 4.2] Brake adjustment
- [🔧 6.1] Removal of the wheels

Map of functional units

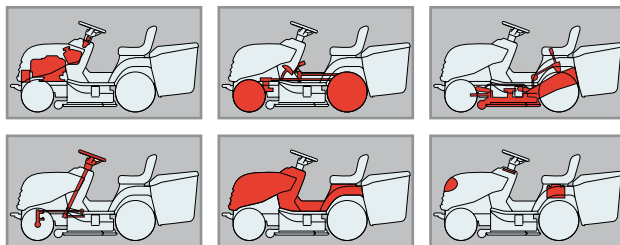

➤ *mechanical drive models only*

🔧 Remove the left-hand rear wheel.

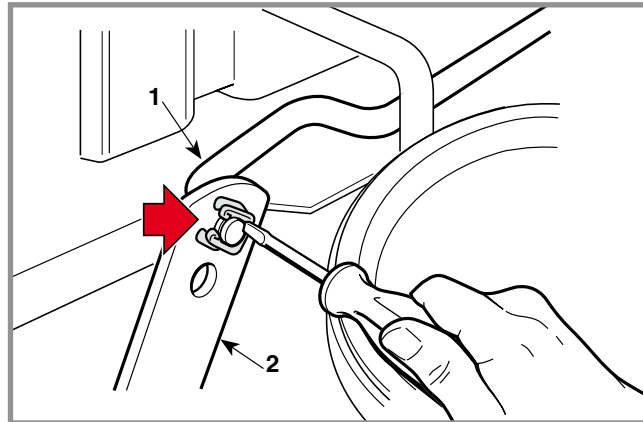

Disconnect the control rod (1) from the lever (2) and undo the two screws (3) which hold on the support (4).

NOTE During all these operations it is better to not unscrew or loosen the central screw (9) to avoid altering the calibration of the cam driving the pistons. If it has been moved, the lever's free movement will have to be checked.

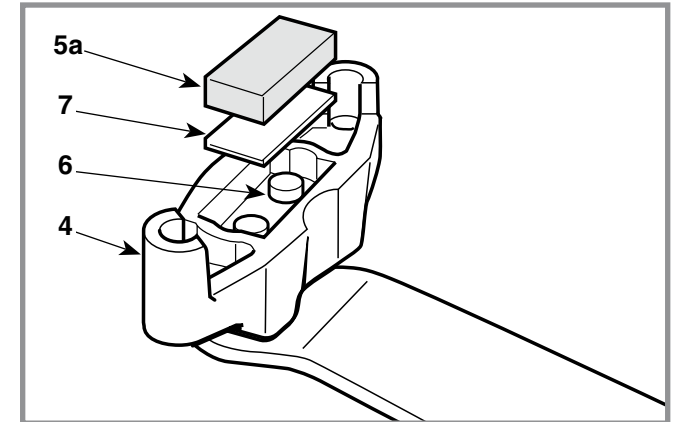
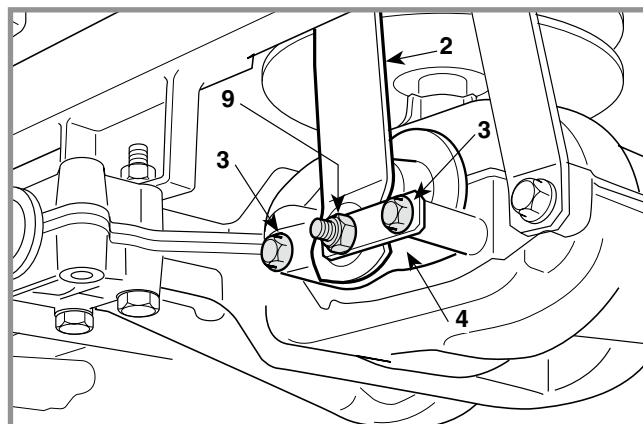

The support (4) contains a pad (5a) separated from the control pistons (6) by a plate (7).

The other pad (5b) can be reached by taking off the disc (8).

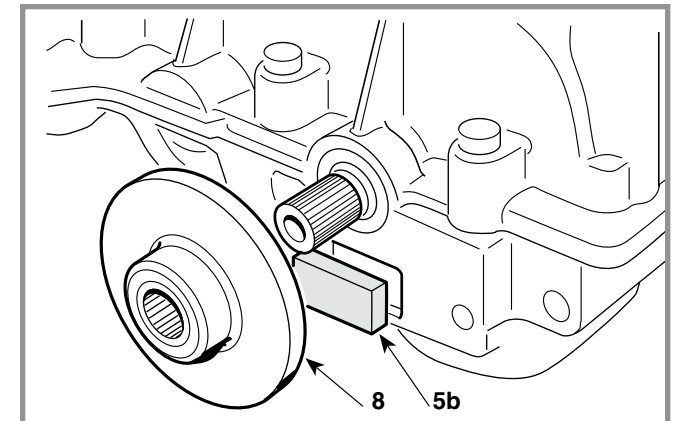

If there is oil on the pads, clean with solvent and go over them with fine-grade abrasive paper.

⚠ Both pads should be replaced if the depth of either of them is less than 5 mm.

⚠ Renew the disc if it is damaged, distorted or less than 4 mm thick.

On reassembly, carefully reposition all the components and refit the complete support.

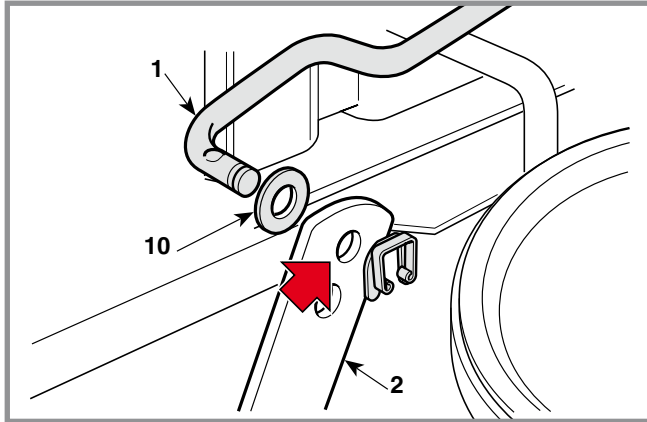

When connecting the rod (1) be sure to use the uppermost hole in the lever (2) and replace the washer (10).

When fully reassembled ...

☞ Check the brake adjustment.

General informations

In the following some of the problems connected to the malfunctioning of the electrical system are shown, with their probable cause and the remedial action to be taken. Should the problem continue after the appropriate checks, seek assistance from your local Service Centre.

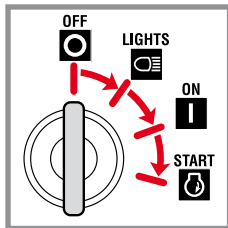

Related topics

- [7.2](#) Table for the cutting in of the safety devices
- [7.3](#) Safety microswitches operation check
- [7.4](#) Terminal board supply check
- [7.6](#) Starter relay operation check
- [7.7](#) Electronic card operation check
- [7.8](#) Recharge circuit check
- [7.9](#) Maintenance of the sealed battery

Map of functional units

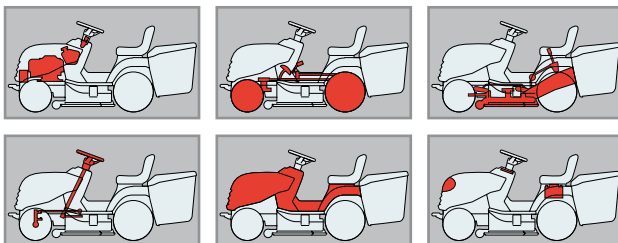

PROBLEM	CAUSE	REMEDY
1. Activation of the self-resetting protection 1)		
a) ... on inserting the key in position «ON»	Battery terminal crossed	Check the battery connections
	Short circuit to earth	Check the connectors and wiring of the microswitches
b) ... in position «START» or after a few seconds use, following an attempt at starting with outside means:	Sulphated battery (it no longer accepts recharging)	Replace the battery
	Faulty or wet electronic card	Check and dry with low pressure tepid air (hair-dryer)
	Disconnected or missing battery	Reconnect the battery. It must always be connected
	Battery terminals corroded or with poor contact	Check and clean the connections
c) ... after several minutes' use:	Poor or missing earth contact on the charge regulator	Check the earth connections and the screws fastening the regulator
	Overvoltage from a malfunction in the regulator	Check the recharge circuit
	Battery disconnected or faulty during use	Check the battery or wiring
2. With the key in the «ON» position the pilot lamp remains off	The battery is not supplying the card	Check the connection cables Check the battery's condition
	Battery or card not earthed to frame	Check and put right
	10 A fuse blown	Replace fuse (10 A)
	Battery terminal crossed	Check connections

! WARNING! The self-setting guard reaches very high temperatures (around 160 °C) which are to be considered normal. Similarly, there might be some smoke inside the box which is due to the overheating of the powder inside. **Do not touch this component of the circuit board until it has cooled down.**

1) Activation of the self-resetting protection of the electronic card is signalled by the failure of the LED to light, by it switching off during work, by the engine running erratically or stopping.

IMPORTANT Faulty electronic cards must always be replaced without trying to repair them or replace single components.

PROBLEM	CAUSE	REMEDY
3. The pilot lamp comes on but, with the key in the «START» position, the starter motor does not turn or lacks power (poor starting)	The battery is not supplying sufficient current	Recharge the battery
	Badly earthed battery, or the starter relay or engine not earthed	Check and put right
	Starter relay is faulty	Check that the starter relay is activated
4. The pilot lamp is flashing with the key in the «START» position and the starter motor does not turn	Starting not permitted	After checking that the conditions are met, check all the microswitches and the relative wiring
5. The starter turns but the engine does not start	No fuel flow	Check the leads for the carburettor solenoid valve opening control (if provided) or check the fuel stopcock and filter
	Impaired starter system	Check that the spark plug cap is positioned correctly Check that the spark plug electrodes are clean and have the correct gap
6. The starter continues to turn after engine has started, and does not stop when the key is removed	Mechanical difficulties with the contact breakers of the starter relay	Replace the starter relay
	Starter works erratically for mechanical or electrical reasons taking excessive current and causing binding of relay contacts	Check the starter
7. The starter operates as soon as the key is in the «ON» position, and can be turned off only by removing the key	Fault in the card	Replace the card
	Starter block operating faults	Replace the block
8. The pilot lamp becomes weak after several hours' work and the engine goes off	Insufficient charge	Check that the charging cable has not detached
		Check that there are no current leakages caused by cables with damaged insulation
	Charger fuse blown	Check the recharge circuit Replace fuse (25 A) and check the recharge circuit

IMPORTANT Faulty electronic cards must always be replaced without trying to repair them or replace single components.

PROBLEM	CAUSE	REMEDY
9. The engine stops while in use for reasons not due to the safety devices cutting in	The safety devices have cut in or are faulty	Check the operation of the microswitch operation and the relevant wiring
	Accidental detaching of an electrical wire	Check all wiring
	Starting of engine not permitted	After checking that the conditions are met, check all the microswitches and the relative wiring.
10. The 10 A fuse cuts in	Short circuit or overload on the power side of the card (ignition block, starter relay, headlamps and recharger connector)	Find and replace the defective user
	Short circuit or damage to the electronic card protection (power side)	Try changing the card with one that is known to work. If the problem stops, replace the faulty card
11. The 25 A fuse cuts in	Faults in the battery charging circuit	Replace fuse (25 A) and check the recharge circuit
12. No audible signal for the “grass-catcher full” condition	Malfunctioning or faulty blade switch or microswitch and grass-catcher signalling	Check the switch, the microswitch and wiring. WARNING! - Check that the blade switch stops the engine or prevents it from being started if the acknowledgement conditions are not met
	Malfunctioning or faulty electronic card	Try changing the card with one that is known to work. If the problem stops, replace the faulty card

General informations

Related topics

[7.3](#) Safety microswitches operation check

Map of functional units

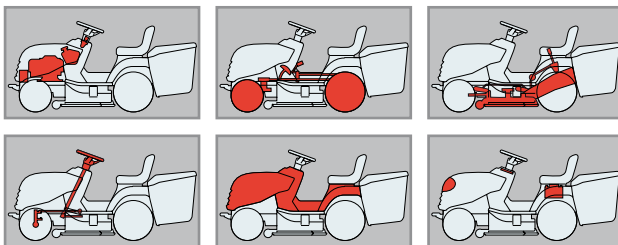

This table shows the various situations in which the safety devices intervene.

A) STARTING («START» position)

The engine DOES NOT start, when:

Operator	-/-	-/-	Absent
Grass-Catcher	-/-	-/-	-/-
Blades	-/-	Engaged	-/-
Drive	Engaged	-/-	-/-
Parking	-/-	-/-	-/-
Indication on the Dashboard			

B) WHILE CUTTING

The engine STOPS start, when:

Operator	Absent	Absent	Absent	-/-	-/-	Seated
Grass-Catcher	-/-	-/-	-/-	Missing	-/-	Fitted
Blades	-/-	Engaged	-/-	Engaged	Engaged	Engaged
Drive	Engaged	-/-	-/-	-/-	-/-	Reverse
Consent Button	-/-	-/-	-/-	-/-	-/-	Released
Parking	-/-	-/-	-/-	-/-	Engaged	-/-
Indication on the Dashboard						

-/- Irrelevant condition for the triggering of safety devices

= Pilot lamp on = Pilot lamp flashing

General informations

Related topics

Map of functional units

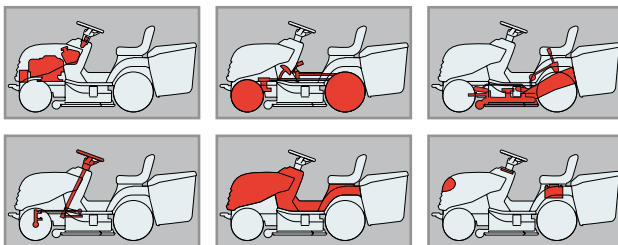

This check is done by disconnecting connector CN1 and using the tester in Ohmmeter mode.

This operation must be performed without the operator aboard, making contact with the ferrules on the contacts of the wiring connector (1) and must give these results:

N° Contacts	Tester reading and condition		
GRASS-CATCHER ATTACHED MICROSWITCH			
10 - 6	∞ (without g.catc.)	O (with g.catcher)	
SEAT MICROSWITCH			
10 - 14	∞ (absent)	O (seated)	
PARKING MICROSWITCH			
10 - 17	O (free)	∞ (engaged)	
BLADE SWITCH			
10 - 16	∞ (engaged)	O (disengaged)	
"IN NEUTRAL" SIGNAL			
10 - 7	∞ (drive)	O (neutral)	
GRASS-CATCHER FULL MICROSWITCH			
13 - Earth	O (full)	∞ (empty)	
REVERSE GEAR MICROSWITCH			
10 - 15	∞ (Pressed)	O (Released)	
REVERSE CONSENT BUTTON			
8 - 9	O (Pressed)	∞ (Released)	
STARTER UNIT			
+ Battery - 11	∞ (OFF)	O (ON)	O (START)
+ Battery - 12	∞ (OFF)	∞ (ON)	O (START)

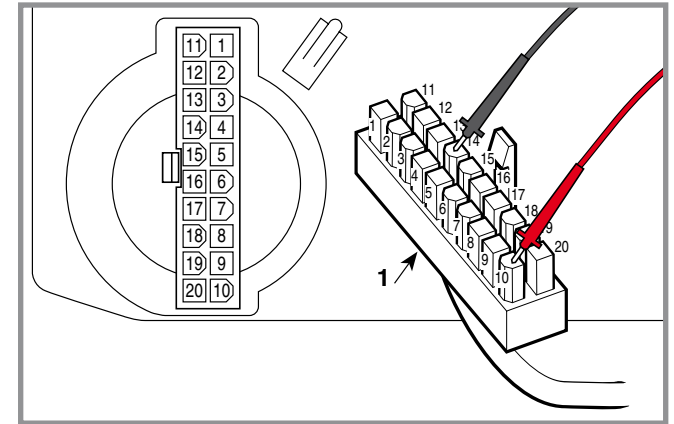

ENGINE STOP

This operation must be done by keeping the connector (1) attached and should give this result:

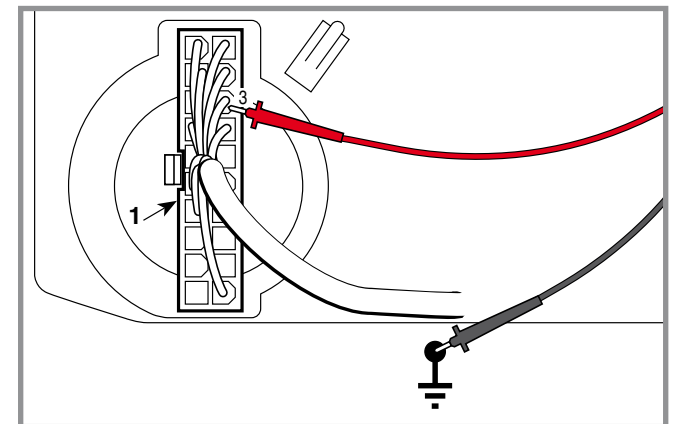

N° Contacts	Tester reading and condition
3 - Earth	O (Always)

General informations

Related topics

This check is made with the tester operating as a Voltmeter (Volts DC 0 ÷ 20), with the black ferrule on terminal 1 and the red one on terminal 11 of the connector (1) of the wiring.

- The key in the «ON» position

The reading shows the battery voltage, which should never go below 11 Volts.

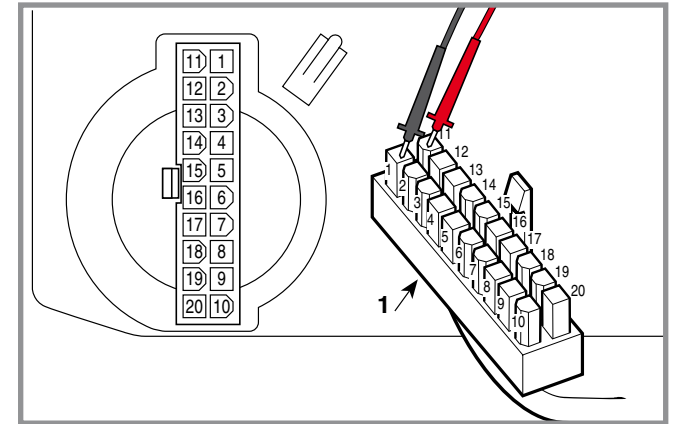

Map of functional units

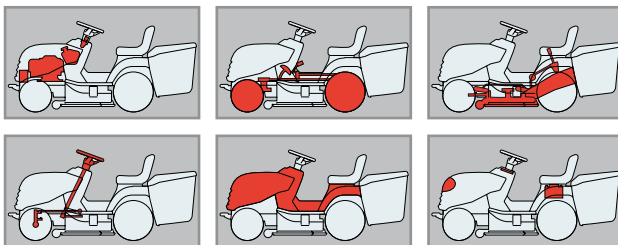

General informations

Related topics

[7.3](#) Safety microswitches operation check

Map of functional units

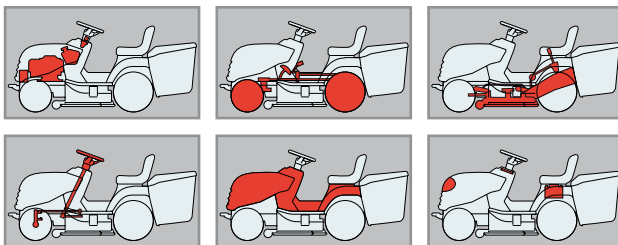

⚠ WARNING! *This check must be made with the engine off.*

Disconnect connector CN1 and bridge terminals 2 and 11 of cabling connector CN1 (1).

With the key set to «ON», when the switch is operated a click must be heard from the moving part of the clutch, due to excitation of the electric wiring.

If this is not so, check the operation of the cabling and control switch.

The clutch must be replaced if engagement does not take place after these checks.

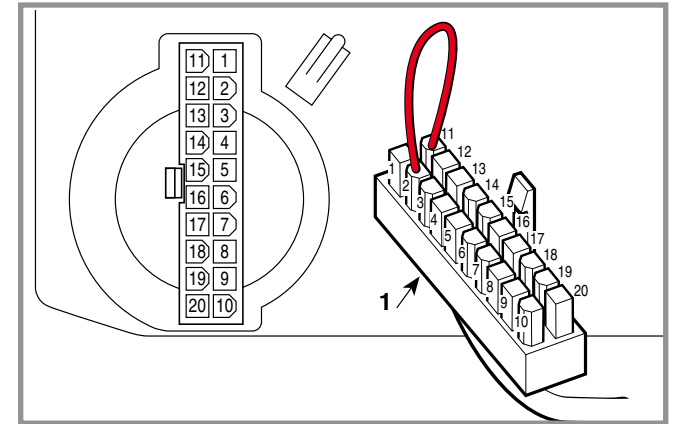

General informations

Related topics

Map of functional units

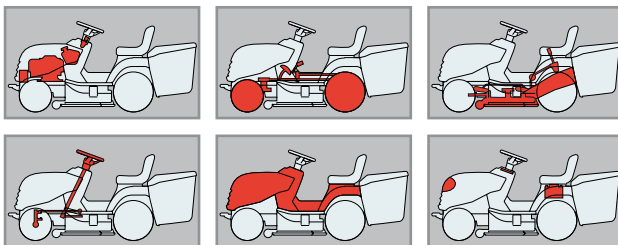

⚠ WARNING! Remove the cap of the sparking plug (or plugs), since the safety systems that normally prevent accidental starting of the engine are cut out when the checking procedure is carried out.

To do this requires:

- operator seated,
- blades disengaged,
- the key in the «ON» position.

Disconnect the connector (1).

In making a bridge between the terminals 11 and 4 of the wiring connector (1), the click of the relay bobbin should be heard and the starter motor should come into action.

- **➤ except Honda engines:**
- If the bobbin clicks but the starter does not start, make a bridge (2) with a large section cable (5 mm²) between the power contacts of the relay.
- If the starter comes into operation, look for the fault within the relay or replace it. Otherwise, check the starter together with its wiring.

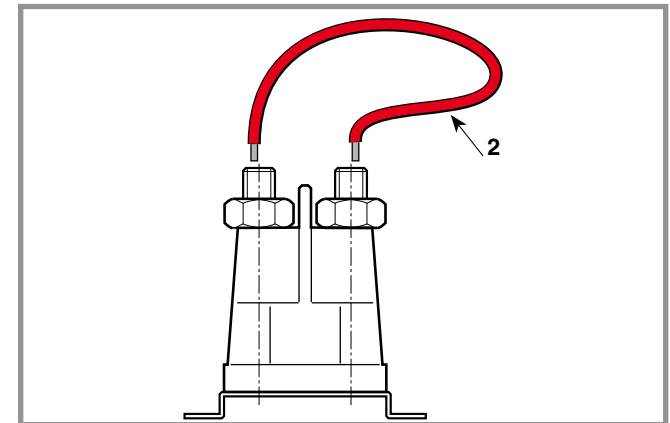
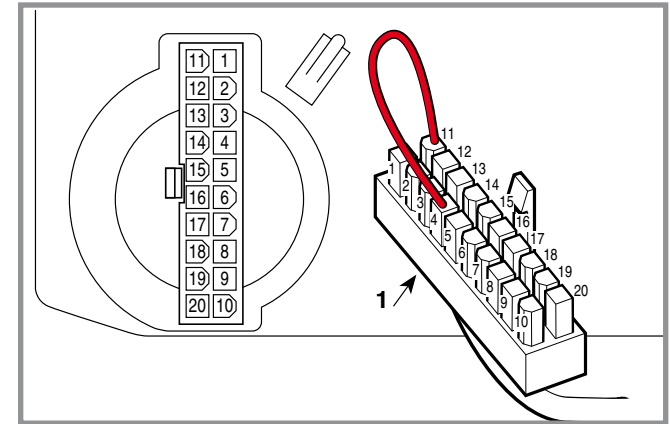

General informations:

Related topics:

Map of functional units

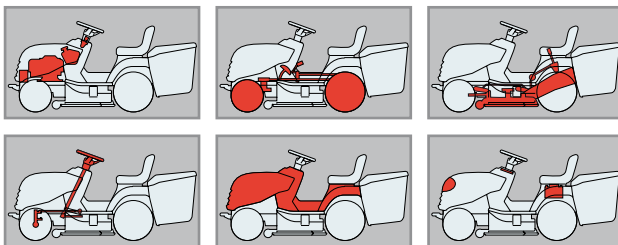

To make this tests it is necessary to have:

- The key in the «ON» position
- Connector (1) connected to the card.

In this situation the pilot lamp should come on.

A) Card supply

This check is done with the tester in Voltmeter function (Volt DC 0 ÷ 20), with the black ferrule on terminal 1 and the red ferrule on terminal 11 of the wiring connector (1).

The reading on the tester shows the battery's voltage.

B) Safety and service supply check

This check is done with the tester in Voltmeter function (Volt DC 0 ÷ 20), with the black ferrule to earth and the red ferrule on terminal 10 of the wiring connector (1).

The reading on the tester shows a slightly lower battery voltage value than that produced by the test described in section "A".

C) Checking the operation of the self-setting protection

By connecting terminal 10 of the connector (1) to the frame's earth, the pilot lamp should go out due to the protection cutting in; eliminating the connection to earth, the pilot lamp should come on again.

NOTE During this test, the self-setting protection reaches very high temperatures (around 160 °C) which are to be considered normal. Similarly, there might be some smoke inside the transparent box which is due to the overheating of the powder inside.

 **WARNING!** Do not touch this component of the card until it has cooled down.

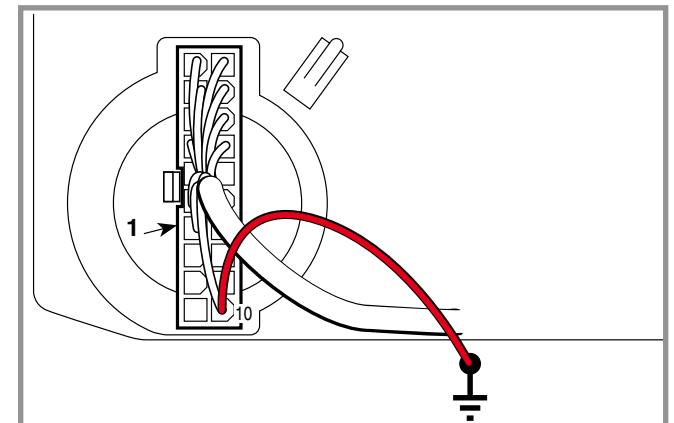
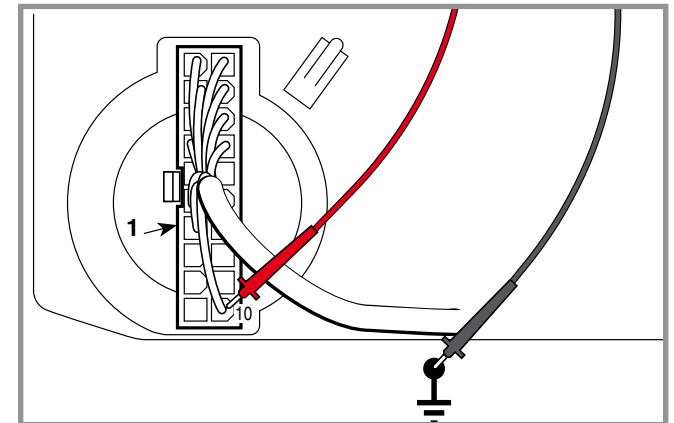
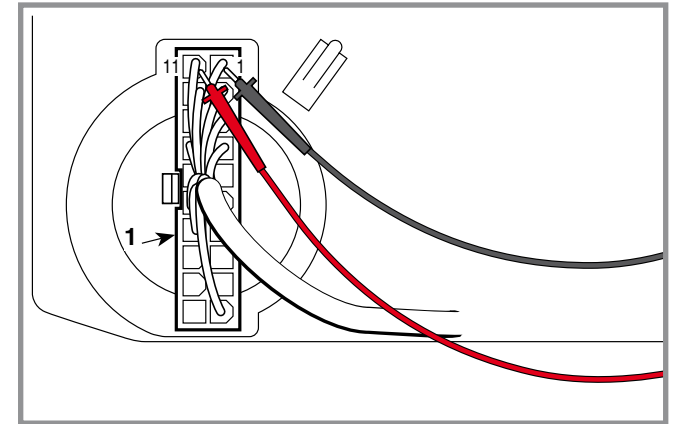

General informations

Related topics

Map of functional units

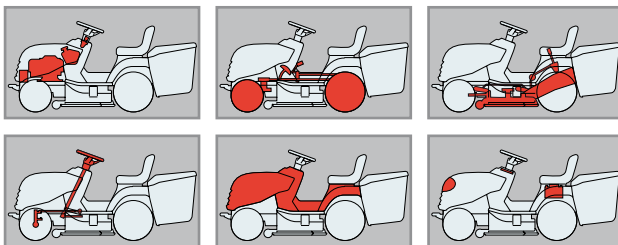

A) General information

In a sealed “dual” battery, the electrolyte for each element is carefully measured out during manufacture and sealed at source, in order to ensure maximum performance during the battery’s entire life.

With a battery of this type, it is not necessary to add water or acid, and the cover must never be opened or removed.

B) Recommendations for correct use

To keep the battery performing at optimum levels and to increase its life, various precautions should be taken:

- always keep the battery fully charged;
- always recharge a flat battery within 1 month, otherwise the elements could be damaged and no longer able to take the charge (sulphated);
- always recharge the battery before and after periods of prolonged inactivity or storage.

IMPORTANT! Only recharge with a constant voltage battery charger. Use of other types of battery charger could damage the battery.

C) Rules for recharging the battery

La ricarica è una operazione particolarmente IMPOR- Recharging is a particularly important operation for the life of the battery and must be carried out according to these instructions:

- do not recharge the battery when its case is broken or damaged;
- carefully read the instructions for using the battery charger and the battery;
- use a suitable battery charger;
- recharge at a room temperature of between +10 and +30 °C;
- check that the battery does not heat to beyond 50 °C while recharging. If it should do so, stop recharging immediately and dispose of the battery since it will be unusable.

With the battery disconnected (and at rest for at least 12 hours) and the tester in voltmeter function, measure the voltage between the terminals. The amount given (open circuit voltage) gives an indication of the operations to be carried out, as per the following table:

Battery voltage with open circuit	Battery state	Operation to be carried out
> 12.6 Volt	Fully charged	None
< 12,4 Volt	Flat	Recharge

Check the battery voltage at least 12-24 hours after recharging.

General informations

Related topics

! **IMPORTANT!** *If the microswitches are to function correctly, it is important to follow the exact assembly positions by referring to the drawings that indicate the various usages of each type.*

A = Free
B = Activated

Map of functional units

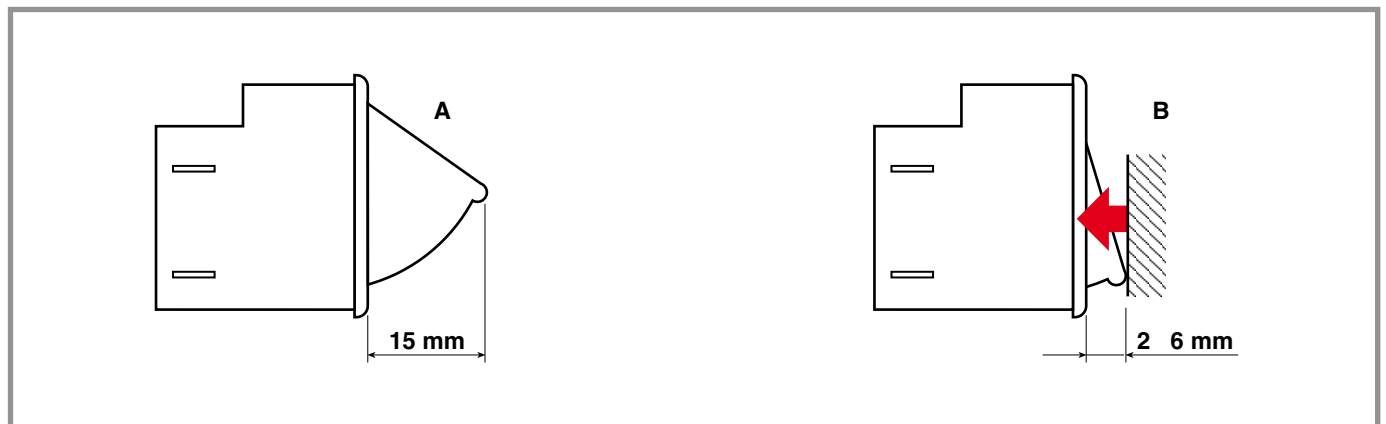
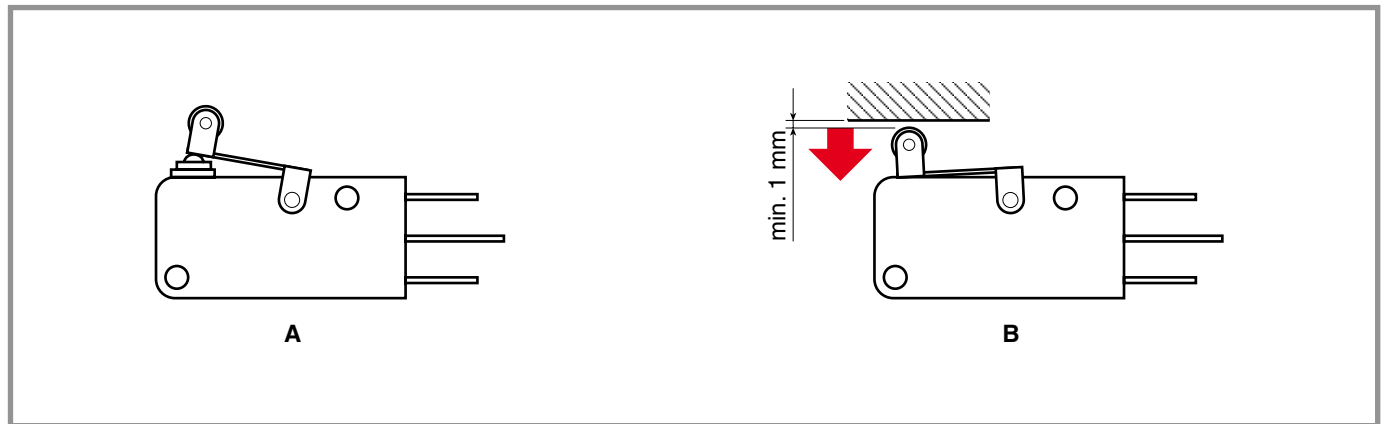
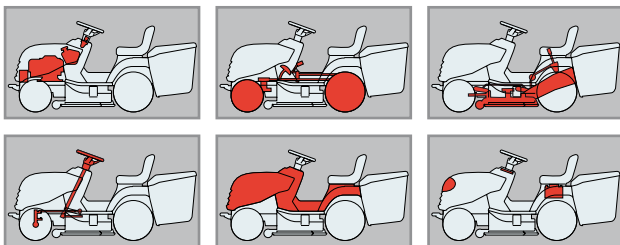

General informations

Related topics

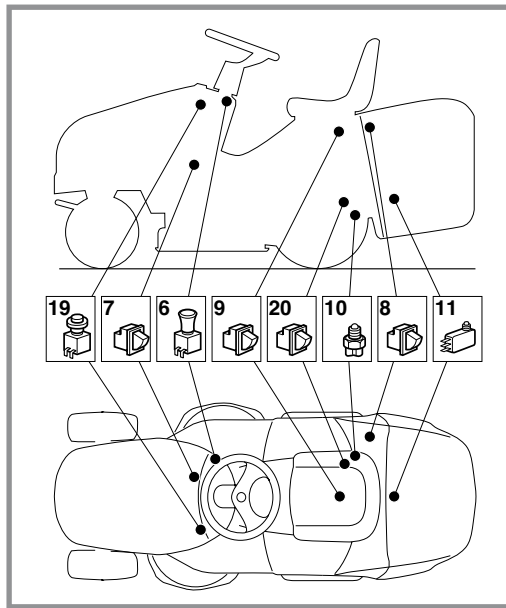

Map of functional units

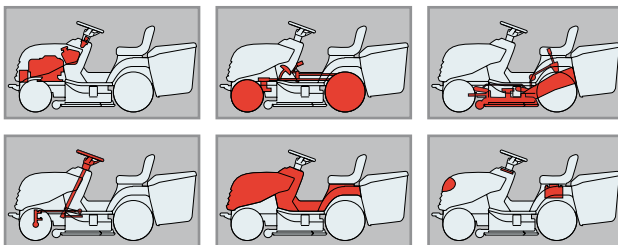

Engines B&S - Stiga

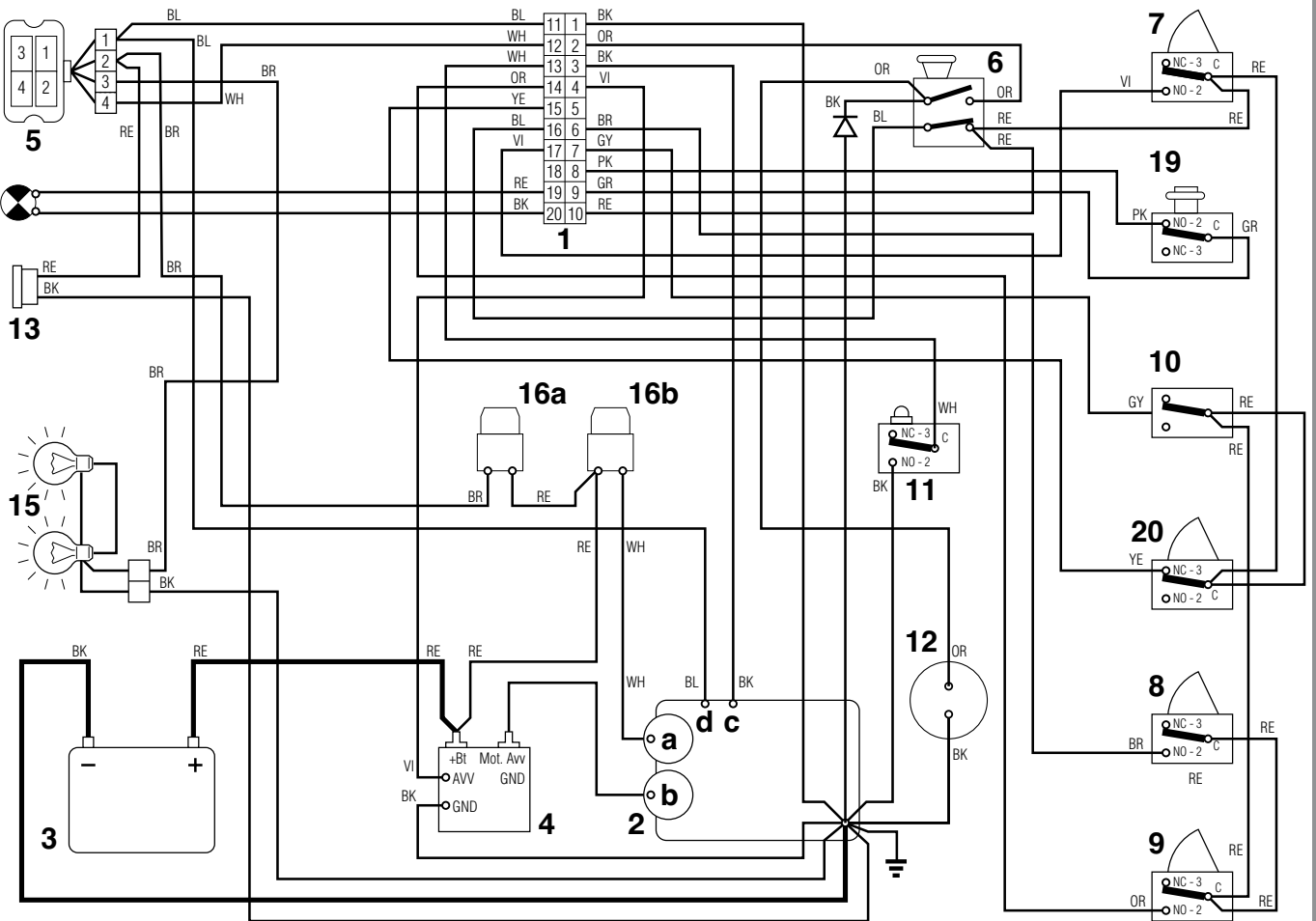

- | | | | |
|----|--------------------------|-----|-------------------------------|
| 1 | Electronic card | 10 | Neutral microswitch |
| 2 | Engine | 11 | Grasscatcher full microswitch |
| 2a | Generator | 12 | Clutch |
| 2b | Starter motor | 13 | Recharge connector |
| 2c | Engine stop | 15 | Headlight |
| 2d | Carburattor | 16a | 10 A fuse |
| 3 | Battery | 16b | 25 A fuse |
| 4 | Starter relay | 19 | Reverse consent button |
| 5 | Key ignition switch | 20 | Reverse gear microswitch |
| 6 | Blades switch | | |
| 7 | Brake microswitch | | |
| 8 | Grasscatcher microswitch | | |
| 9 | Seat microswitch | | |

CABLE COLOURS

- | | |
|----|--------|
| BK | Black |
| BL | Blue |
| GR | Green |
| BR | Brown |
| GY | Grey |
| OR | Orange |
| PK | Pink |
| RE | Red |
| VI | Violet |
| WH | White |
| YE | Yellow |

General informations

Related topics

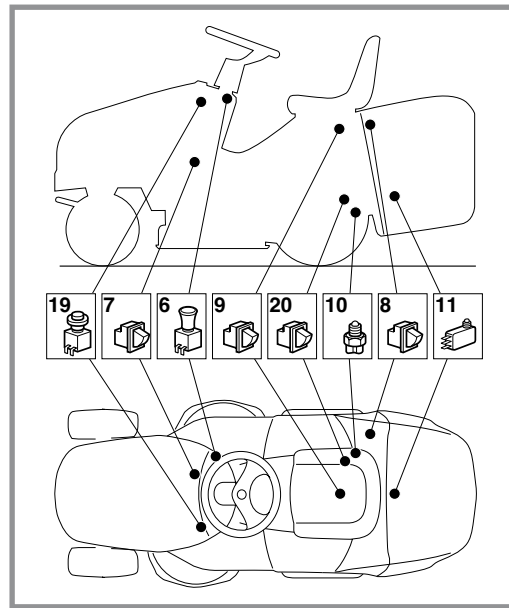

Map of functional units

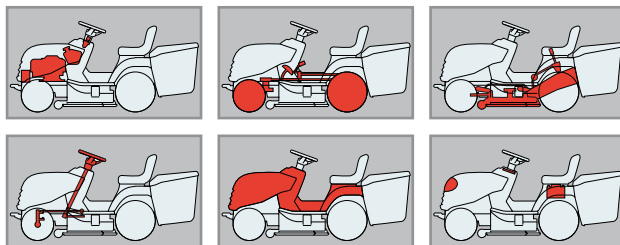

Engines Honda

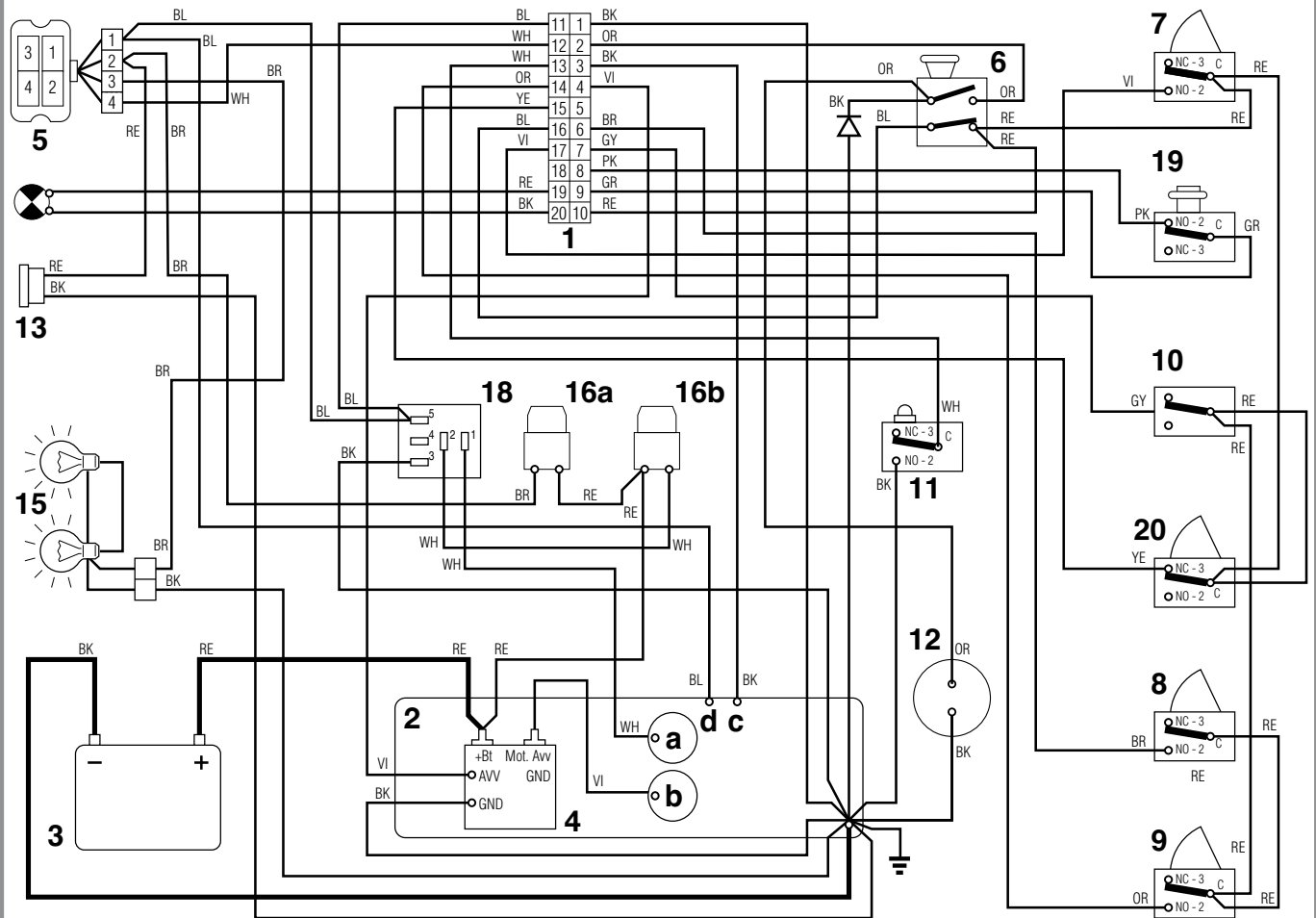



- | | |
|----------------------------|----------------------------------|
| 1 Electronic card | 10 Neutral microswitch |
| 2 Engine | 11 Grasscatcher full microswitch |
| 2a Generator | 12 Clutch |
| 2b Starter motor | 13 Recharge connector |
| 2c Engine stop | 15 Headlight |
| 2d Carburattor | 16a 10 A fuse |
| 2e Starter relay | 16b 25 A fuse |
| 3 Battery | 18 Relay |
| 5 Key ignition switch | 19 Reverse consent button |
| 6 Blades switch | 20 Reverse gear microswitch |
| 7 Brake microswitch | |
| 8 Grasscatcher microswitch | |
| 9 Seat microswitch | |

CABLE COLOURS

- | | |
|----|--------|
| K | Black |
| BL | Blue |
| GR | Green |
| BR | Brown |
| GY | Grey |
| OR | Orange |
| PK | Pink |
| RE | Red |
| VI | Violet |
| WH | White |
| YE | Yellow |

General informations

Related topics

-  **4.1** Adjusting the engagement and checking the blade brake
-  **4.2** Brake adjustment
-  **4.3** Drive belt adjustment

Map of functional units

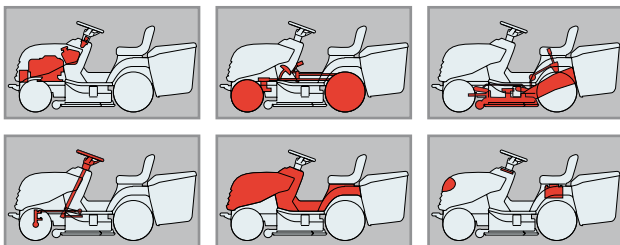

A) Tightening torques

Below are the specified tightening torques for the fixing bolts on the main parts.

- 1 Screws for engine fastening 35 ÷ 40 Nm
- 2 Screw for engine pulley 45 ÷ 50 Nm
- 3 Screws for rear axle fastening 25 ÷ 30 Nm
- 4 Blade pulley screws 25 ÷ 30 Nm
- 5 Flanged support fixing nuts 25 ÷ 30 Nm
- 6 Screw for blade 45 ÷ 50 Nm

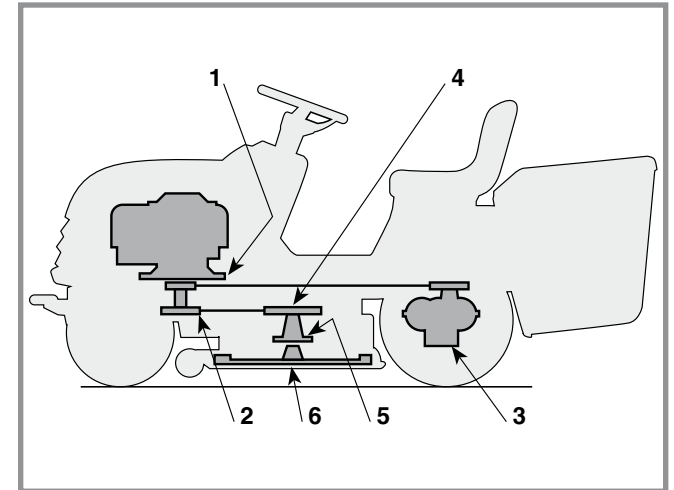

Every section in this manual gives values for all the components involved in each operation.

B) Adjustments

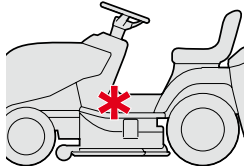
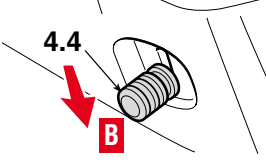
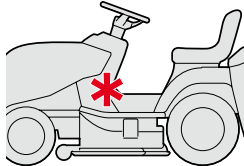
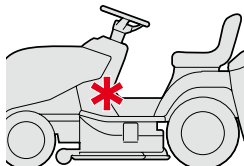
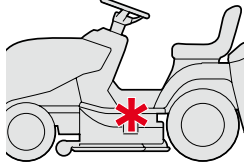
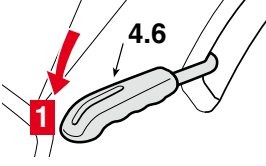
Operation	Position	Position of controls	Adjustment
a) Brake adjustment			43,5 - 45,5 (Peerless) 40 - 42 (Hydro Gear)
b) Drive belt adjustment			156 - 160
c) Adjustment the engagement and checking the blade brake			82 - 85

General informations:

Related topics

[\[6.4\]](#) Replacement of the drive belt

[\[6.6\]](#) Replacement of the blades control belt

Map of functional units

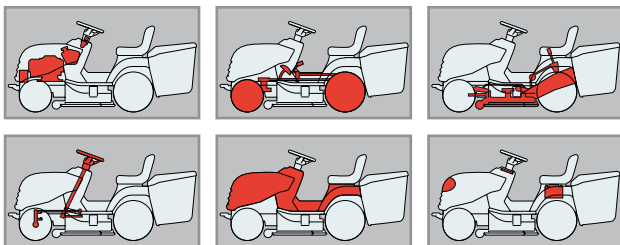

1

➤ *mechanical drive models*

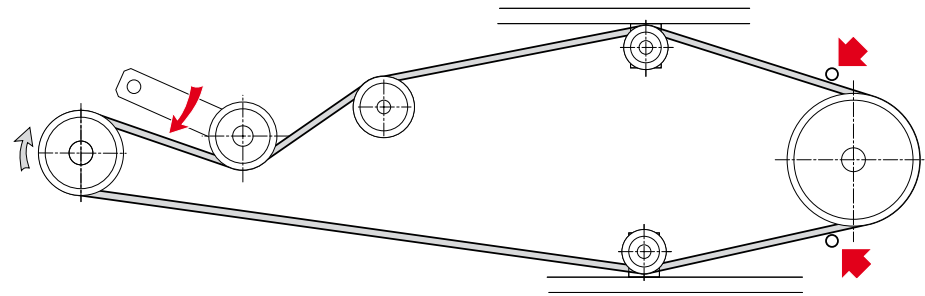

➤ *hydrostatic drive models*

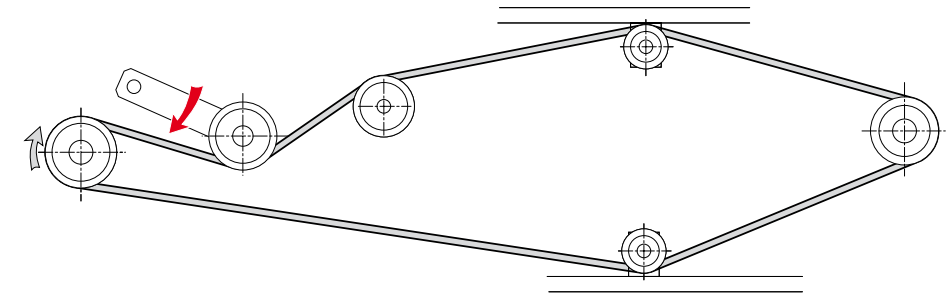

- 1 Drive belt development
- 2 Blades control belt development

2

