

# STIGA

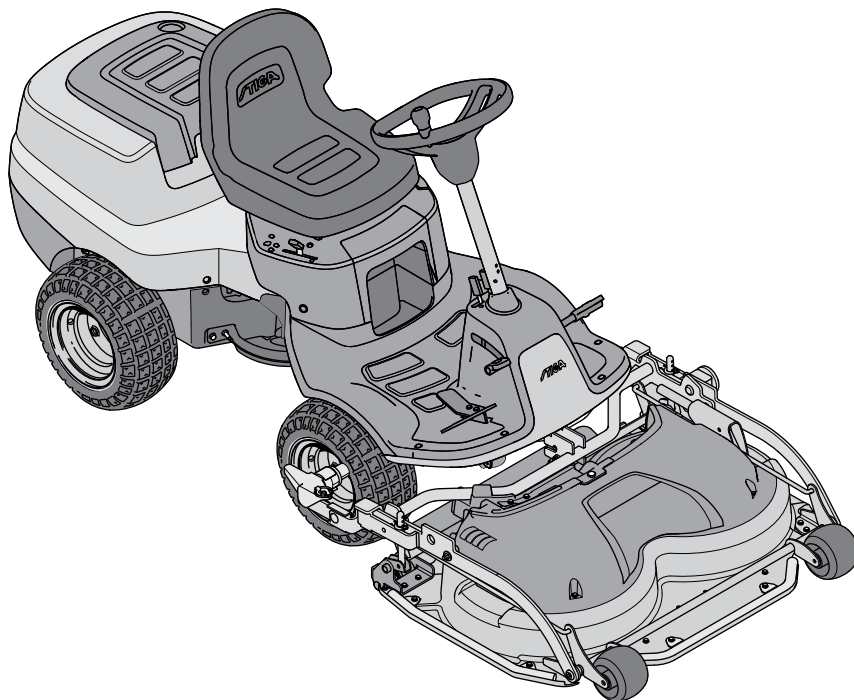

## ***Workshop manual***

**PARK 300 M - PARK 300  
2022**



**The manual is divided into the following chapters:**

<b>1</b>	<b>General instructions</b>	<b>3</b>
<b>2</b>	<b>Frame and Covers</b>	<b>15</b>
<b>3</b>	<b>Steering wheel</b>	<b>23</b>
<b>4</b>	<b>Hydraulic system</b>	<b>28</b>
<b>5</b>	<b>Belts</b>	<b>31</b>
<b>6</b>	<b>Control cables</b>	<b>43</b>
<b>7</b>	<b>Electrical system</b>	<b>51</b>
<b>8</b>	<b>Mower Decks</b>	<b>66</b>

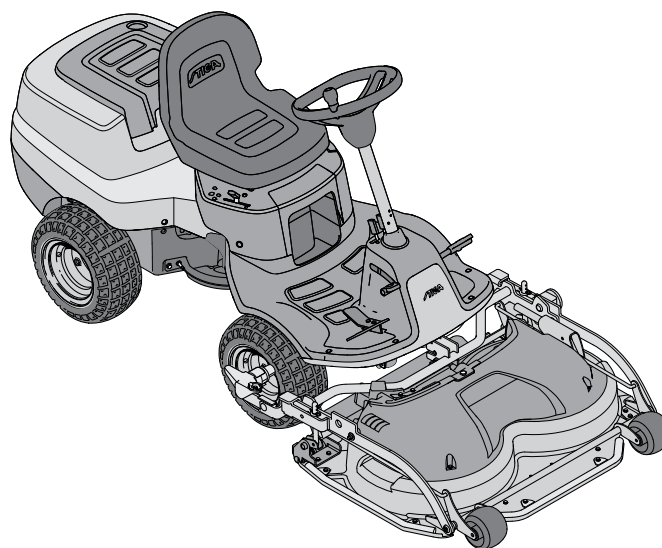

© by STIGA - No use of the illustrations or duplication, reproduction or translation, even partial, of the texts in this document may be made without explicit authorization.

# 1 General instructions

## Table of contents

<b>1.1 Introduction</b> .....	<b>4</b>
1.1.1 Limited liability .....	4
1.1.2 How to read this manual.....	4
1.1.3 Symbols, General warnings.....	4
1.1.4 Abbreviations.....	5
1.1.5 Safety instructions .....	5
1.1.6 Lifting.....	6
1.1.7 Spare parts.....	6
<b>1.2 Warranty</b> .....	<b>6</b>
1.2.1 Warranty period .....	6
1.2.2 Exceptions .....	6
1.2.3 Interventions carried out after warranty expiry .....	7
1.2.4 Reporting faults .....	7
1.2.5 Ordering spare parts.....	7
<b>1.3 Identification</b> .....	<b>8</b>
<b>1.4 Unpacking, assembly</b> .....	<b>9</b>
1.4.1 Assembly .....	9
1.4.2 Battery .....	9
1.4.3 Final inspections.....	10
<b>1.5 Maintenance</b> .....	<b>11</b>
1.5.1 General safety checks .....	12
1.5.2 Electrical safety check .....	12
<b>1.6 Technical data</b> .....	<b>14</b>
1.6.1 Machine dimensions.....	14
1.6.2 General tightening torques .....	14
<b>1.7 User guide</b> .....	<b>14</b>

This manual refers to the PARK 300 M - PARK 300. The technical data can be found also in the "INSTRUCTION MANUAL".

This manual does not contemplate repairs to the engine or the transmission. In the event of any problems concerning engines and transmission parts, contact the relative Service Centre.

This manual and relative specifications refer to the machine in its original state. This manual does not cover machines which have undergone modifications designed to alter the machine itself.

## 1.1 Introduction

### 1.1.1 Limited liability

Despite the care and attention which has gone into the preparation of this manual, the possibility of errors cannot be excluded. The author is not responsible for any information which may be missing or incorrect. STIGA reserves the right to make changes to the product at regular intervals without prior notice. The information provided in this manual is based on data available at the time of publication. The drawings and photographs herein may not completely match the machine you are working on in every detail.

### 1.1.2 How to read this manual

This manual is divided into chapters, headings and subheadings. The title of the paragraph "2.1 Disassembly/assembly of covers" is a subheading in chapter 2 "Frame and safety guards" References to titles or paragraphs are indicated with the abbreviation "chap." or "par." accompanied by the relative number. Example: "chap. 2" or "par. 2.1".

To facilitate consultation of the manual, each chapter is dedicated to a specific component. There is a table of contents at the beginning of each chapter. The cover, on the other hand, holds a general index of the chapters.

References to paragraphs or subheadings are indicated by the symbol  followed by the paragraph / subheading number, e.g:  **1.1.3**.

### 1.1.3 Symbols, General warnings

This manual makes use of certain symbols. Their function is to bring the attention of the reader to the most important notes so that he can carry out the operations with due caution:

#### Warning!



This symbol indicates that failure to carefully follow the instructions may result in injury.

#### Attention!



This symbol indicates that failure to carefully follow the instructions may result in damage to materials and equipment.

**NOTE** This text highlights the need to read the information carefully.



This symbol indicates a reference to another section of the manual. Click on the number to go to the section indicated.



Highlights all the operations which require different methods of intervention depending on the version of the machine, any modifications which have been made over time and the accessories installed.



**NOTE**

**All the indications “front”, “back”, “right” and “left” are in relation to the position of the seated operator.**

**The description of elementary operations which any good mechanic should be able to perform have deliberately been left out of this manual, giving preference to more specific aspects with indications of the most suitable methods for optimum execution of the works.**

**Please take care to read all the contents in this manual so as to become familiar with the machine: this is essential if you want to work rationally on the machine without making mistakes and wasting time.**

**Remember that all problems connected with use of the machine are amply covered in the User Manual.**

**Hot parts**

Please note that the engine and exhaust systems heat up significantly during use. To avoid the risk of injury, give the engine and exhaust system time to cool down before starting any repair or maintenance work on the machine.

**1.1.4 Abbreviations**

The following abbreviations are used in this manual:

Chap. = Chapter - Par. = Paragraph - HST = Hydrostatic Transmission - PTO = Power Take-Off.

**1.1.5 Safety instructions****A. Level of technician training**

All maintenance, disassembly and repair operations must be carried out by expert maintenance mechanics who are familiar with all the safety and accident prevention regulations and have read the procedures described in this manual

**B. Safety principles to be implemented**

All the machines have been built in compliance with the strictest European standards on safety. To keep the initial level of safety unaltered over time, it is important for the Service Centre to act accordingly and carry out all necessary checks and inspections whenever possible.

In particular, each time work on the machine is requested it must:

**1. check:**

- correct operation of the safety microswitches;
- that none of the safety guards or devices have been removed;
- that none of the safety/warning decals have become illegible/damaged (these are considered integral parts of the safety devices).

**2. it must also:**

- restore correct operation of any safety devices which may have been removed or tampered with;
- reinstall any ineffective, damaged and/or missing safeguards;
- replace any illegible decals;
- avoid carrying out any work or modification to the machine or engine which changes its operating performance or could lead to use of the machine which is improper or in any case different to the use it was designed and homologated to carry out;
- inform the Customer that any failure to observe the aforementioned points will automatically nullify the warranty and exonerate the manufacturer from all liability.

## C. Precautions during work

The interventions described herein do not usually entail any particularly hazardous situations except for those usually linked to any kind of mechanical work. Any risks can be avoided by taking the usual amount care and attention required for this kind of work. As well as observance of the usual rules and regulations on the prevention of accidents common to workshops, please remember to:

- remove the keys from the ignition before commencing any work;
- protect hands with suitable work gloves, especially when working on or near the cutting device;
- make sure that the work in progress does not lead to any accidental fuel leaks or spills;
- never smoke when working on the fuel tank or handling fuel;
- not inhale oil or fuel fumes;
- immediately clean up any traces of spilt fuel;
- test the engine only in a well ventilated environment or in the presence of an adequate exhaust fumes extractor system;
- not disperse oil, fuel or other hazardous waste into the environment. This kind of waste must be disposed of in compliance with the relative legislation in force;
- make sure no-one can inadvertently carry out actions which could compromise the safety of the mechanic working on the machine.

## D. Tools required

All the operations described herein can be carried out using the tools usually available in a good vehicle repair workshop.

### 1.1.6 Lifting

Before starting any work under the machine, check the load capacity of the lifting equipment or the jack.

### 1.1.7 Spare parts

Always use genuine spare parts for repairs.

## 1.2 Warranty

### 1.2.1 Warranty period

The warranty is provided in the way and within the limits in the contract. With regards the engine and transmission unit, the warranty terms provided by the relative manufacturer are valid.

### 1.2.2 Exceptions

The warranty does not cover damage caused by:

- Failure of the user to become familiar with the documentation accompanying the machine.
- Carelessness.
- Incorrect or prohibited use and installation.
- The use of non-original spares.
- The use of accessories not supplied or approved by STIGA.

Further more, the warranty does not cover:

- Wear components, such as blades, belts, wheels, batteries, cables.
- Normal wear and tear.
- Engine and transmission. These components are covered by the warranty provided by the relative manufacturer, in compliance with the specified terms and conditions.

The purchaser is covered by the national legislation in force in his country. Purchaser's rights envisaged by national laws are not in any way restricted by this warranty.

### **1.2.3 Interventions carried out after warranty expiry**

For each intervention carried out on the machine, the Service Centre must fill in the report indicating the machine's serial number, a brief indication of the problem encountered, the operations performed and any spare parts used.

A copy of said reports must be kept and made available to the Manufacture, together with any replaced parts in the event of complaints from the Customer.

### **1.2.4 Reporting faults**

Please report any faults which may recur with particular frequency to the Manufacturer so that the problem in question can be duly investigated and corrective action implemented during the production stage.

In the same way the Manufacturer will notify the Service Centre of any faults encountered on the machines produced and provide indications on the best way to deal with them.

### **1.2.5 Ordering spare parts**

When ordering spare parts it is essential to cite the code number (for reference use the explosion diagram corresponding to the year of manufacture) indicated on the product's identification label.

### 1.3 Identification

#### Machine

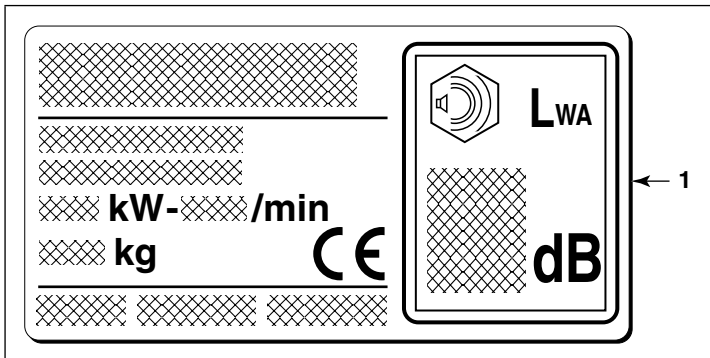

Each machine is supplied with a label (1) affixed behind the seat, indicating the technical data, the model and the serial number.

The model and serial number must be indicated on the intervention sheet, when requesting application of the warranty and are indispensable in the ordering of spare parts.

#### Transmission

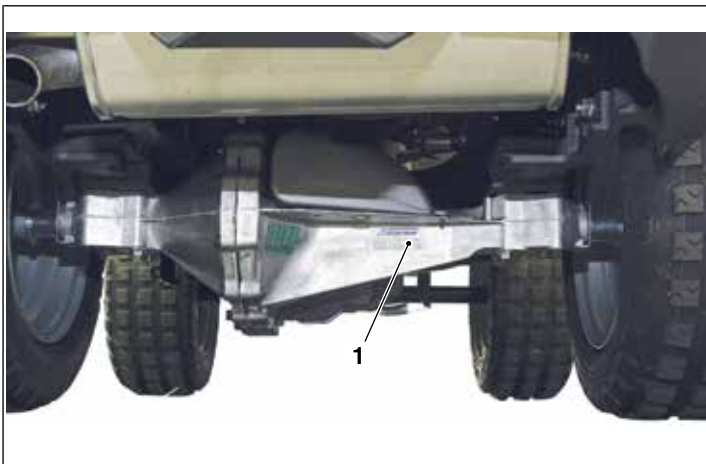

This machine is equipped with 1 hydrostatic transmission.

This component is supplied by an external manufacturer and is built to precise technical specifications which distinguish it from similar products made by the same manufacturer. The serial number indicated on the label (1) makes it possible to correctly identify the product and its characteristics and must always be cited when ordering spare parts or requesting any information from the Manufacturer.

#### Engine



The engine is built to precise technical specifications which distinguish it from similar products made by the same manufacturer. The serial number indicated on the label (1) makes it possible to correctly identify the product and its characteristics and must always be cited when ordering spare parts or requesting any information from the Manufacturer.

## 1.4 Unpacking, assembly

All STIGA machines undergo thorough inspection before delivery. Machines are delivered as fully assembled as possible. This means that final assembly after delivery is quick and easy.

### Attention!



The machine must stay on the pallet while it is being unpacked and assembled.

### 1.4.1 Assembly

For assembly instructions,  [7.4.6](#)

### 1.4.2 Battery

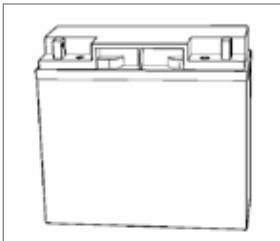

- The battery is a valve-regulated one.

Install/remove the battery in accordance with the instructions provided in chapter 7

 [7.4.6](#)

### Valve-regulated battery

This type of battery requires minimum maintenance. It has no caps or electrolyte level controls.

### Warning!



- Never wear metal rings, bracelets, necklaces or other similar jewellery when working on batteries. They could create a short-circuit or fire.
- The battery must be fully charged before being used for the first time. The battery must be fully charged before being put into storage. Serious damage may occur if the battery is put into storage flat.
- If the leads are disconnected/connected in the wrong order, there is a risk of a short-circuit and damage to the battery.
- Inverting the cables on the poles may damage the battery and the alternator.
- The engine must never be used with the battery disconnected. This could damage the alternator and the electrical system.

## Charging by the engine

The battery can be charged by the machine's alternator as follows:

1. Install the battery in the machine.
2. Position the machine outside or set up an exhaust fumes extraction device.
3. Start the engine in accordance with the indications in the instructions for use.
4. Leave the machine in continuous operation for 45 minutes (not applicable for completely flat batteries).
5. Stop the motor. The battery will now be fully charged.

## Charging with a battery charger

When charging the battery with a battery charger, make sure it is a genuine STIGA battery charger. The battery will be damaged if other battery chargers are used.

### 1.4.3 Final inspections

#### Interventions before start-up

Before starting the machine proceed as follows:

















- Check/top-up the fuel.
- Check/adjust the engine oil level.
- Check the tyre pressure.
- Carry out safety checks.
- Test drive.

#### Test drive

The engine must run at minimum revs to reach the correct operating temperature before carrying out the test drive. For more detailed instructions, refer to the instruction manual. Operate the machine for a few minutes. Check all the various functions. In particular check that the safety devices all work properly.

If a cutting device or other equipment is envisaged, these devices must be installed before carrying out the test drive with the machine.

## 1.5 Maintenance

Maintenance point	First time	Maintenance interval	See Chap. par.
	"Service hours/ Months"		
General safety checks.	5	50/12	 <a href="#">1.5.1</a>  <a href="#">1.5.2</a>
Tyre pressure, check, adjust.	5	50/12	 <a href="#">Tyre, air pressure</a>
Engine oil, change.	5	50/12	 <a href="#">Engine oil</a>
Drive belts, check.	5	50/12	 <a href="#">Drive belts, check</a>
Steering adjustment.	5	50/12	 <a href="#">Steering, adjustment</a>
Lubrication of the bearings in the articulation.	5	50/12	 <a href="#">2.3</a>
Lubrication of the shaft on the front wheels and quick connections.		50/12	 <a href="#">2.3</a>
Engine air filter, clean/change.		100/24	 <a href="#">Engine air filter</a>
Spark plug, change/replace.		100/24	 <a href="#">Spark plug</a>
Transmission, check.		100/24	 <a href="#">Transmission</a>
Exhaust system, check.		100/24	 <a href="#">Exhaust system</a>
Electrical system, check.		100/24	 <a href="#">Electrical system</a>
PTO, check.		100/24	 <a href="#">Power take-off</a>
Check controls.		100/24	 <a href="#">Check controls</a>
Valve play.		100/24	For the engine, refer to the dedicated manual
Test driving.		100/24	 <a href="#">Test drive</a>

### 1.5.1 General safety checks

Object	Result
Fuel lines and connections.	No leaks.
Power cables.	All insulation intact. No mechanical damage.
Exhaust system.	No leakage at the joins. All screws tightened.
Test drive.	No abnormal vibrations. No abnormal noise.

### 1.5.2 Electrical safety check

Status	Action	Result
Driver not seated. Parking brake engaged.	Try to start the engine.	The motor does not start.
Driver not seated. Parking brake disengaged.	Try to start the engine.	The motor does not start.
Driver seated. Parking brake engaged.	Try to start the engine.	The engine starts.
Engine on, cutting device disengaged, parking brake engaged.	The driver gets up from the seat.	The engine turn off.

### Tyre, air pressure

Check the tyre pressure. Adjust if necessary. The recommended tyre pressure is 1 bar.

### Engine oil

See the manual provided by the engine manufacturer.  [4.6](#)

### Drive belts, check

Check the condition of all the belts and tensioners.  [5.2](#)

### Steering, adjustment

See chapter 3  [3.1.3](#).

### Engine air filter

Consult the "INSTRUCTION MANUAL" supplied with the machine. Also see the manual provided by the engine manufacturer.



## Spark plug

Remove the spark plug and clean or replace it as required. Also see the manual provided by the engine manufacturer.

## Transmission

Check for any abnormal noises.

## Exhaust system

Check that there are no cracks, leakage or other types of damage. Check the hook up devices. Also see the manual provided by the engine manufacturer.

## Electrical system

Check there are no damaged cables, contacts or other devices. Check that all cables are securely fastened to the frame using the relative cable ties. Check that none of the cables rub against the frame as this could lead to damaged cables and short circuits. Check the tightness of the battery terminals.  7.

## Check controls

Check that all the controls function properly and that there is no jamming or excessive play. Adjust if necessary.  6.

## Power take-off

Check that the magnetic clutch engages rotation of the accessory in the preset time and that it does not slip during operation at normal load. Replace the clutch if necessary.

Check that the PTO belt engages rotation of the accessory in the preset time and that it does not slip during operation at normal load. Adjust if necessary.

Check that the PTO brake (if present) stops any rotation within a specific time. Adjust if necessary.

The stopping time must never exceed 3 seconds.

## 1.6 Technical data

For all the Technical Date, see the "INSTRUCTION MANUAL".

### 1.6.1 Machine dimensions

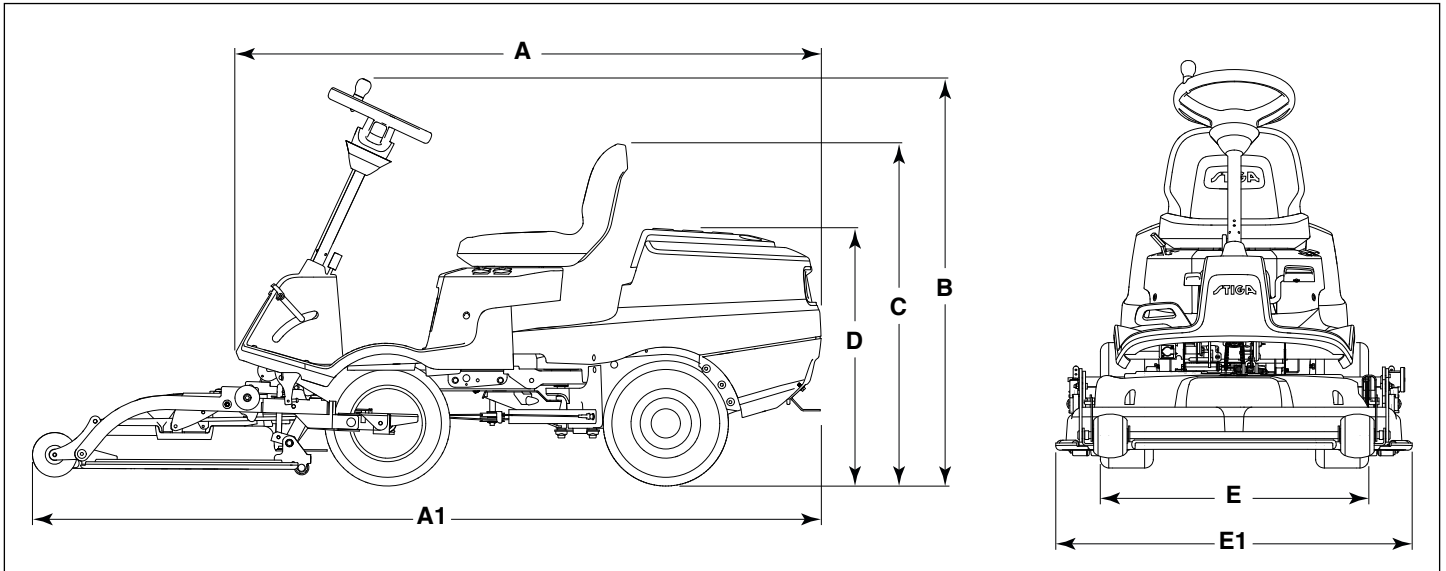

	U.M	DECK 85	DECK 95
A	mm	1681	1681
A1	mm	2252	2279
B	mm	1171	1171
C	mm	984	984
D	mm	741	741
E	mm	770	770
E1	mm	991	1023

### 1.6.2 General tightening torques

Tightening torques for screws and nuts unless otherwise specified:

Thread	Torque
M5	6 Nm
M6	10 Nm
M8	24 Nm
M10	47 Nm

## 1.7 User guide

Certain procedures, for example how to change the engine oil, replace filters, etc. refer to the instruction manuals supplied with the machine.

The instructions for use are available on the GGP Parts & Service website.

For further information go to STIGA website:  
<http://www.stiga.com>.

## 2 Frame and Covers

### Table of contents

<b>2.1 Disassembly/assembly of covers.....</b>	<b>16</b>
2.1.1 Removing the engine cover.....	16
2.1.2 Fitting new screw mounts to the engine cover .....	16
2.1.3 Removing the front covers.....	17
2.1.4 Removing the belt cover at the centre of the machine .....	20
<b>2.2 Replacing the link arm.....</b>	<b>21</b>
<b>2.3 Lubrification .....</b>	<b>22</b>

This chapter provides a brief description of how to disassemble and assemble the machine frame and safety guards.

## 2.1 Disassembly/assembly of covers

### 2.1.1 Removing the engine cover

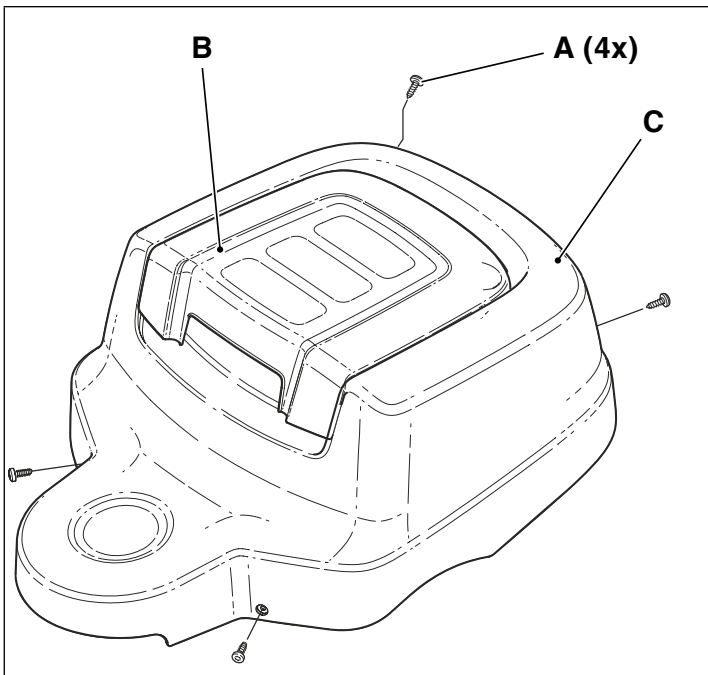

1. Unscrew the four screws (A) holding the cover, use torx T30.
2. Open the cover.
3. Take the cap off the petrol tank.
4. Reclose the cover.
5. Remove the cover.
6. Replace the cap on the petrol tank.

To reassemble the various parts, repeat the operations in reverse order.

### 2.1.2 Fitting new screw mounts to the engine cover

New screw mounts can be mounted on the rear frame if the previous screw mounts are faulty.

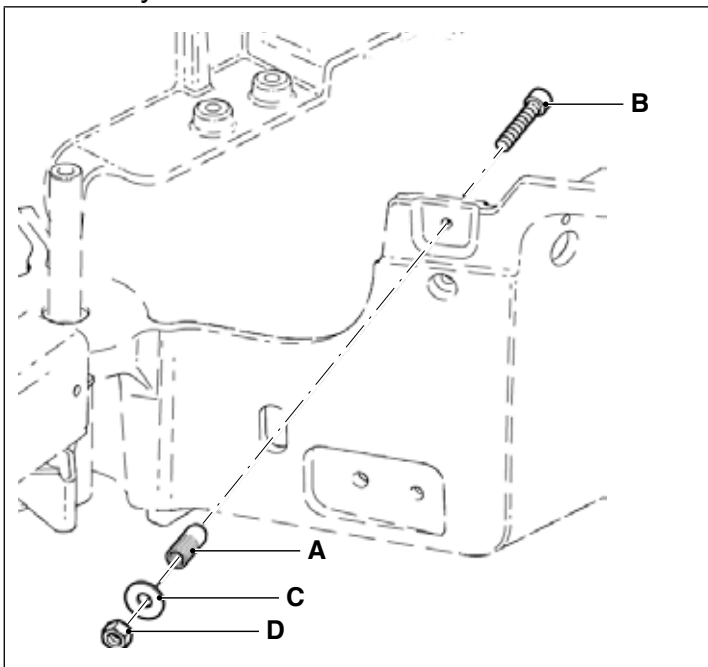

#### Remove the faulty screw mount as follows:

1. Use a 8.5 mm drill. Drill down to the thread from the outside.
2. Pull out the screw mount from the inside with pliers.

#### Install new as follows:

1. Install the rivet (A) from the outside, with the flange outward.
2. Assemble screw (B) is screwed through the rivet, from within.
3. Put on the washer (C) and the nut (D), from the outside.
4. Hold the screw and tighten the nut so the rivet expands and locks into the rear frame. The rivet should not rotate!
5. Remove the assembly screw and mount cover with regular screws.

### 2.1.3 Removing the front covers

#### Removing the steering wheel

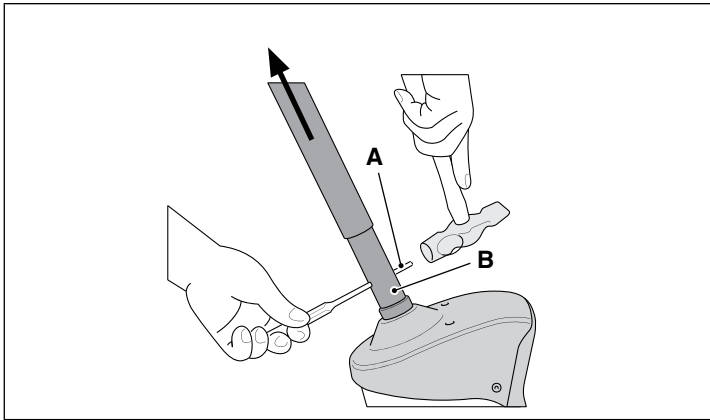

1. Slacken the wing nut.
2. Lift the steering wheel to uncover the two pins.
3. Tighten the wing nut.
4. Remove the two pins (A) from the sleeve (B).
5. Remove the steering wheel.

#### Removing the seat

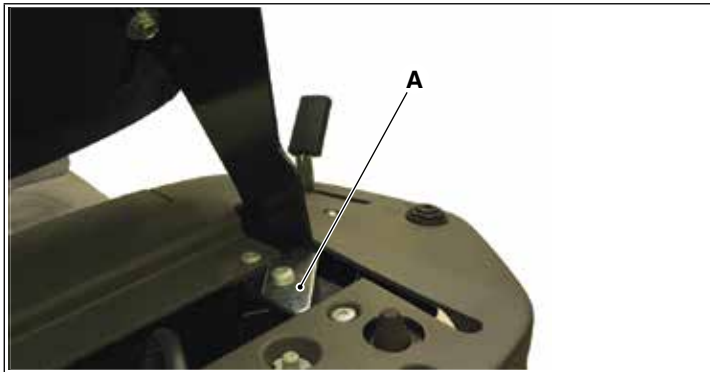

1. Tip the seat back.
2. Activate the anti-roll lever (A) and set the seat down.

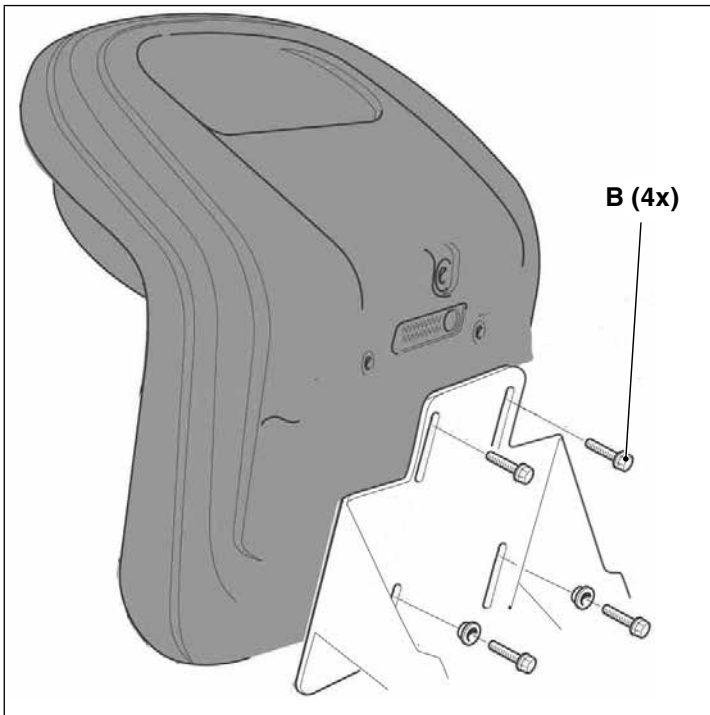

3. Remove the seat, four screws (B).

## Removing the controls

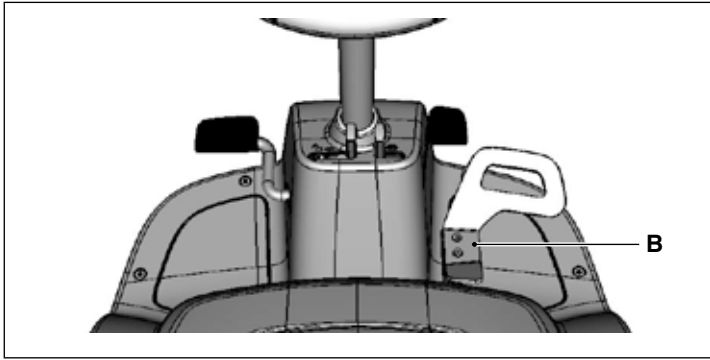

1. Remove the drive pedal, two screws (B).

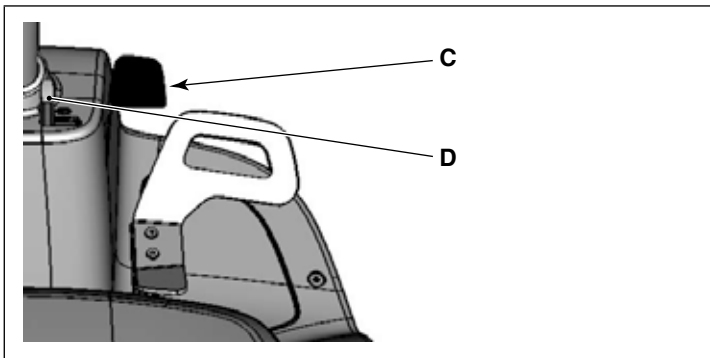

2. Remove the parking brake pedal, screw (C). Also remove the plastic knob (D) by pulling it straight up.



3. Remove the lift pedal, screw (E). Also remove the plastic knob (F) by pulling it straight up.

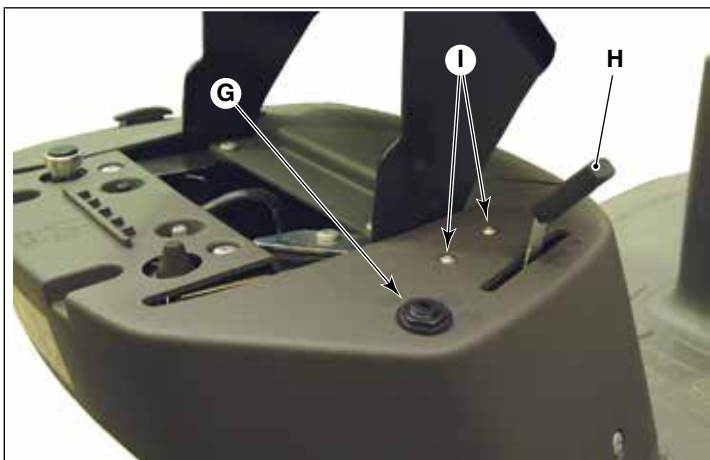

4. Remove the ignition switch nut (G). Use a 22 mm wrench to not damage the panel.
5. Remove the plastic knob (H) to the throttle control, pull the knob straight up. Then remove the throttle control, two screws (I).

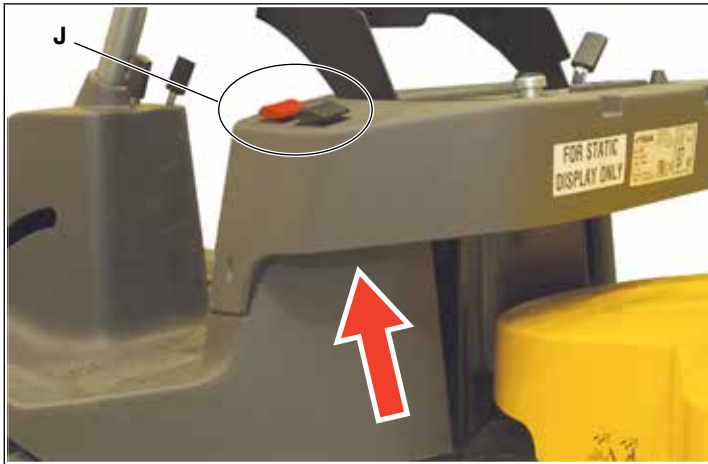

6. Remove the fruits from the switches (J) by operating from under the covering;  
**NOTE:** the switch levers remain attached to the casing.  7.4.3.

### Removal of the cover under the seat

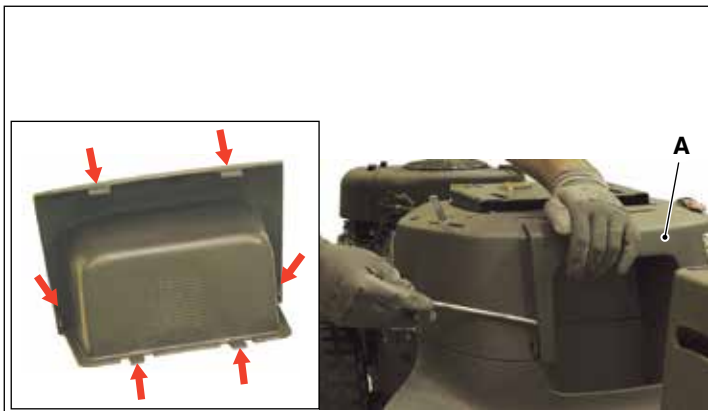

1. Remove the cover (A);  
**NOTE:** operate with great care to avoid breaking the tabs on the cover.  
The locking tabs are at the top and bottom, the two side ones are guide tabs.

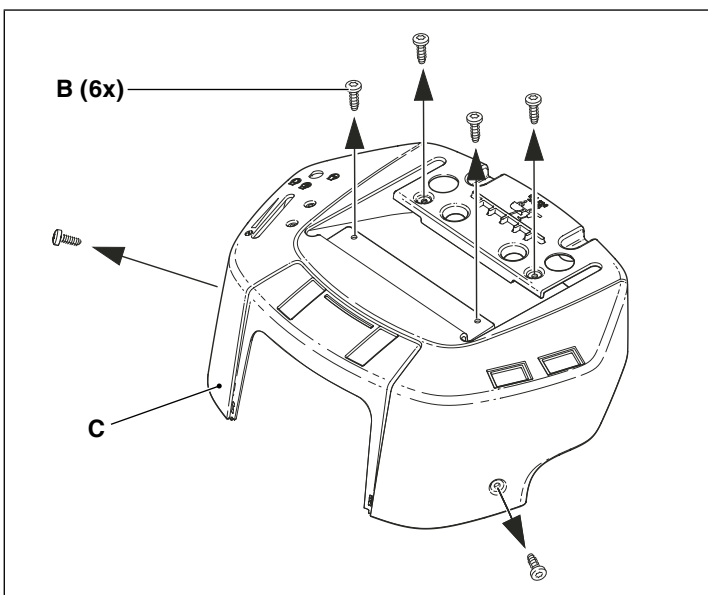

2. Remove the six screws (B) under plate that the seat was mounted on, then lift off the cover (C) and extract it from the seat plate;

## Removal of the front cover

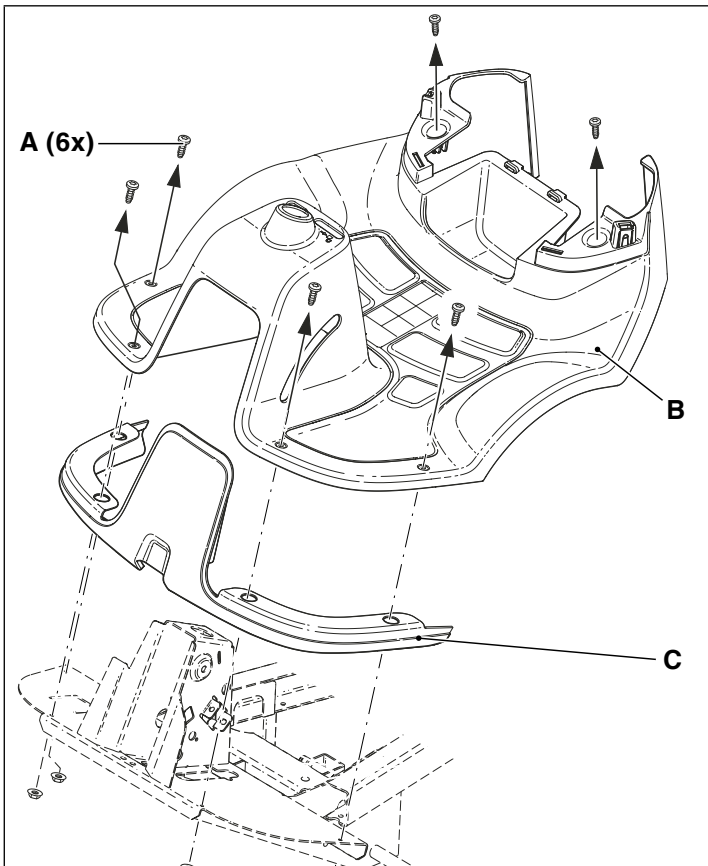

1. Loosen the six screws (A-Torx T30) that hold the covers (B-C) in place.

To reassemble the various parts, repeat the operations in reverse order.

### 2.1.4 Removing the belt cover at the centre of the machine

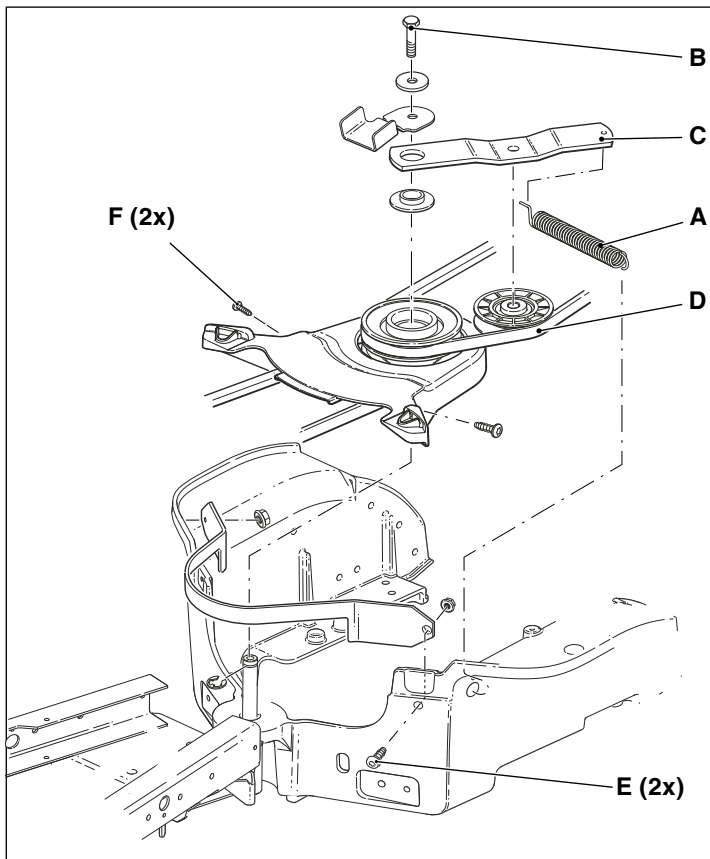

1. Remove the engine cover; for details [2.1.1](#)
2. Remove the spring (A) to tension arm from the frame.
3. Unscrew the bolt (B) (13 mm wrench).
4. Remove the tension arm (C).
5. Remove the belt (D) from the pulley.
6. Disassemble the lower belt cover, two screws (E-Torx wrench T30 + 10mm wrench).
7. Disassemble the upper belt cover, two screws (F).

To reassemble the various parts, repeat the operations in reverse order.



## 2.2 Replacing the link arm

Remove the link arm, as follows:

### Warning!



Support the machine safely, on the rear side of the frame and on the front frame near the arm, to ensure it does not roll over. Keep it lifted using a jack or wooden planks.

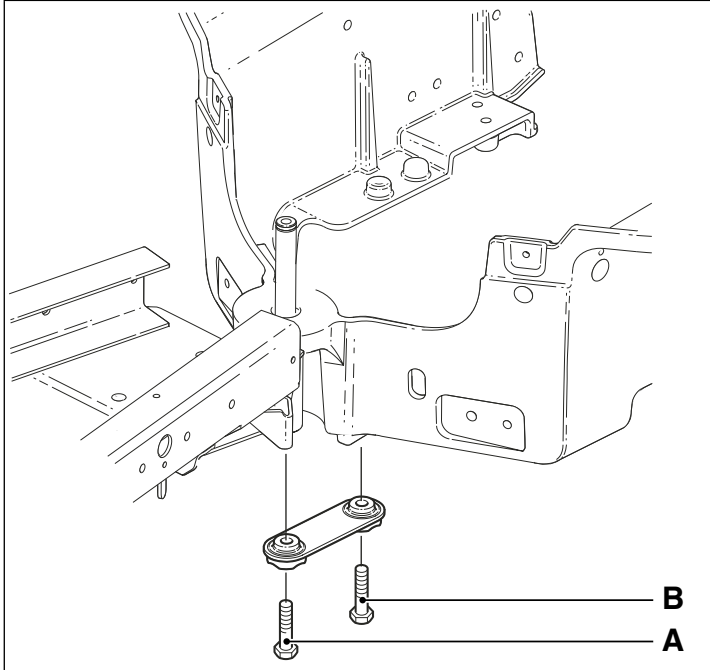

1. Unscrew the bolt (A-17 mm wrench).
2. Unscrew the bolt (B-17 mm wrench).
3. Replace the link arm and then mount it together in reverse order.
4. If it is difficult to fit bolt (A) during assembly, lift up the front frame for an easier mounting of the bolt.

## 2.3 Lubrication

All lubrication points in accordance with the table below must be lubricated every 50 hours of operation as well as after every wash.

View from the top

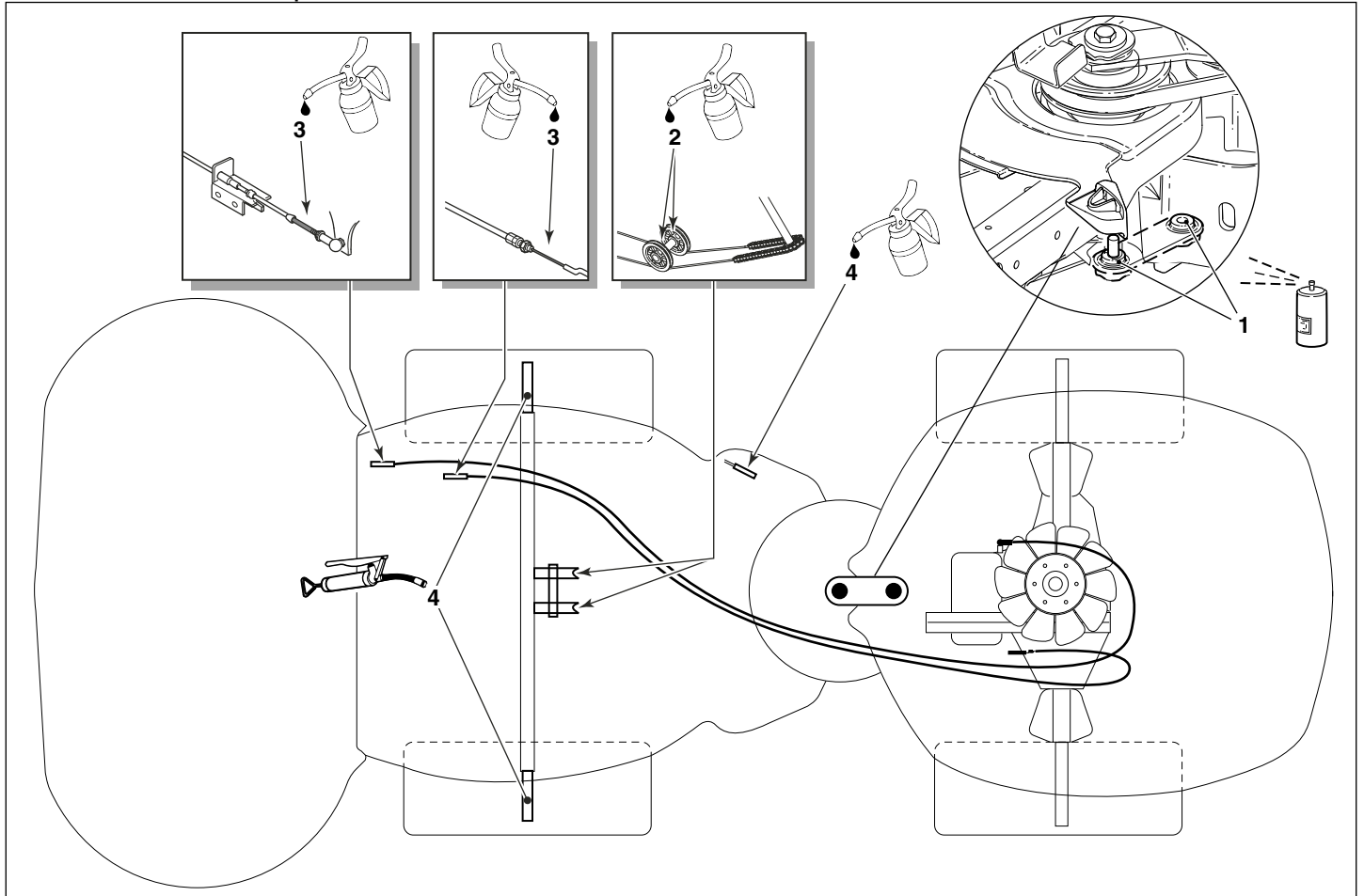

Object	Action	Points
Centre point	Lubricate with oil on the centre point.	1
Steering pulleys	Lubricate the pulley hubs with an oil can.	2
Control cables	Lubricate the cable ends with an oil can when each control is activated.	3
Front wheel axle	Remove the wheels and implement mounts. Lubricate the axle with grease.	4

## 3 Steering wheel

### Table of contents

<b>3.1 Description .....</b>	<b>24</b>
3.1.1 Disassembly .....	24
3.1.2 Reassembly.....	25
3.1.3 Adjustment.....	26
3.1.4 Replacing the bushes on the steering shaft .....	27

### General description

The machine is fitted with a mechanical steering system. Steering power is transmitted by a cable/chain system.

This chapter provides an overview of operation and describes how to repair, replace and adjust worn parts in the steering system.

### 3.1 Description

The chain gear is connected directly to the steering wheel by means of a steering shaft. A chain with cables is connected to the gearwheel and consequently to the rear frame. In this condition the rear frame is forced to steer in relation to the front frame when the driver uses the steering wheel.

#### 3.1.1 Disassembly

Before commencing disassembly operations, make a note of the route taken by the cable/chain system so that the new components can be installed in the exact same way.

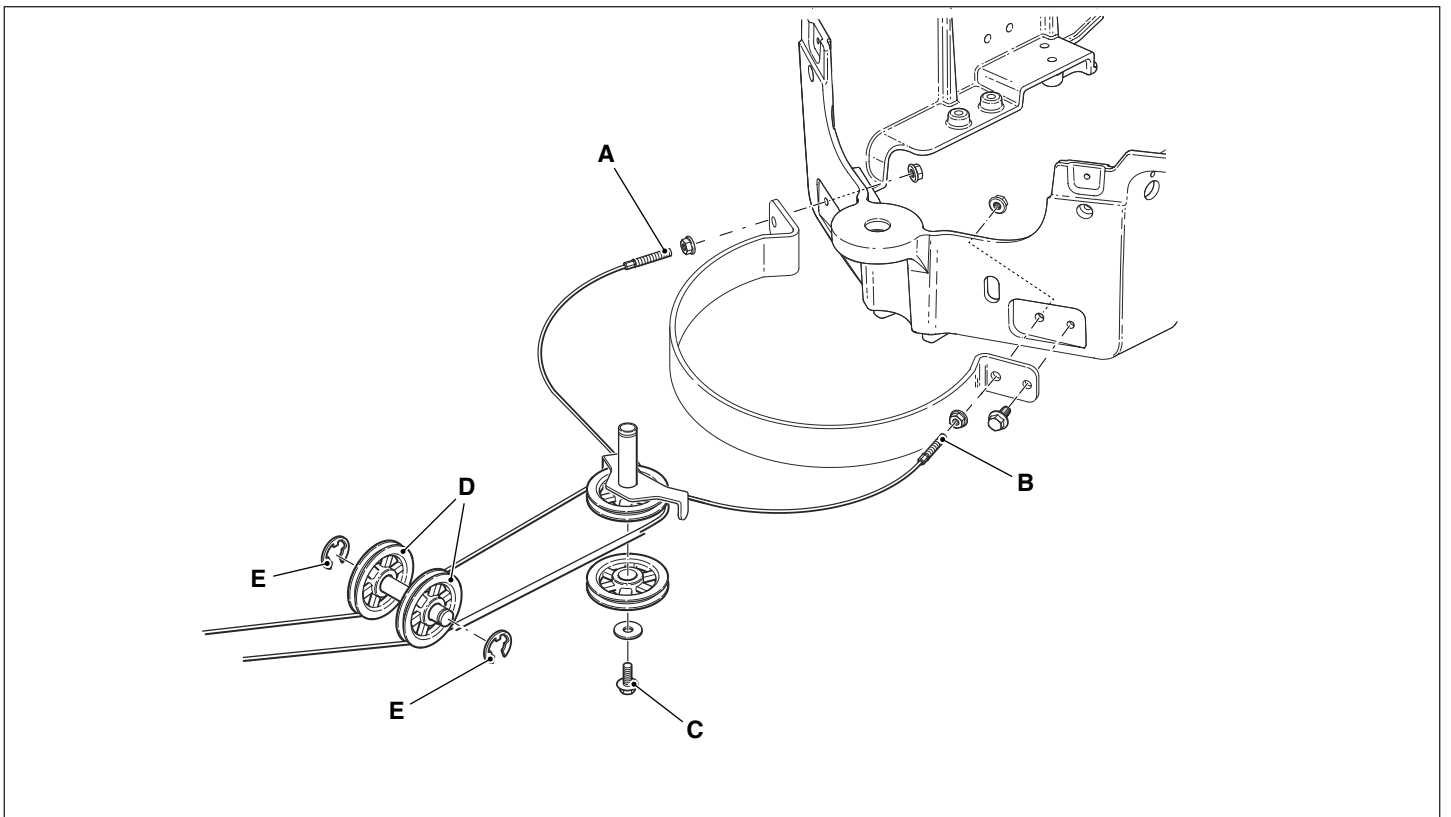

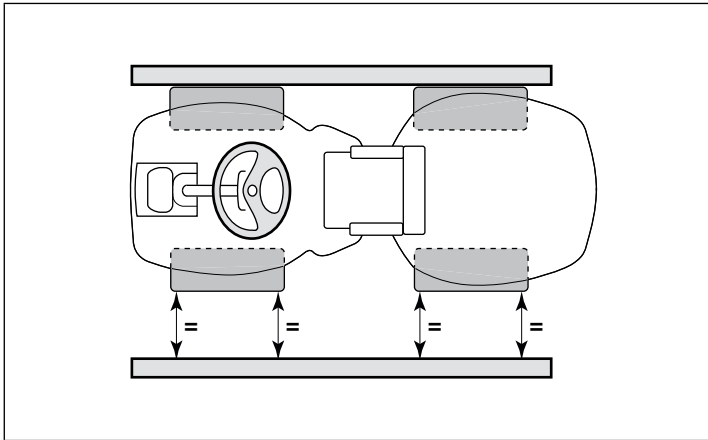

1. Remove one end (A or B) of the cable from the rear part of the frame.
2. Slacken bolt (C) which holds the rear pulleys in place. Slacken the bolt so as to be able to remove the cable from both the top and bottom pulleys.
3. Remove the front pulleys (D) by removing the circlips (E).
4. Slacken the second cable from the frame and completely remove the cable/chain system.

### 3.1.2 Reassembly

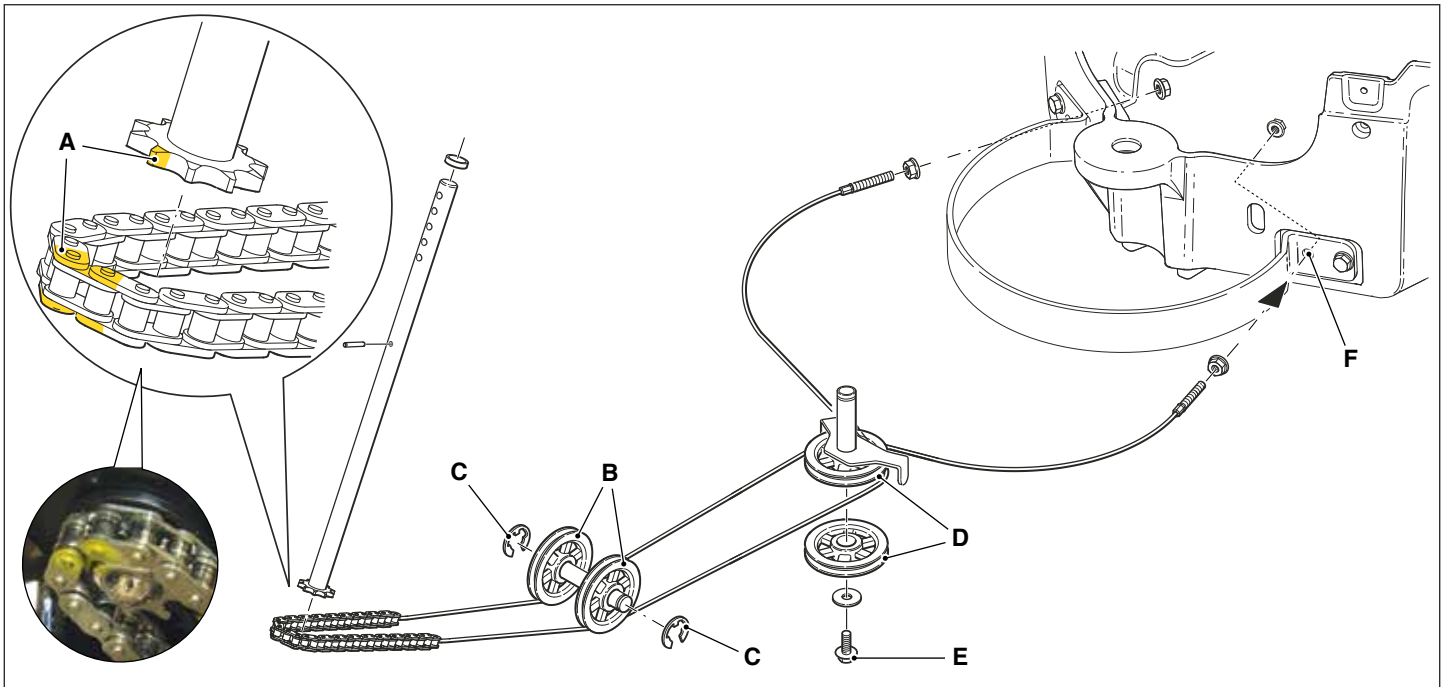

1. Position the machine so that it is completely straight with the steering wheel in the correct position.



2. Measure the length of the chain and mark the middle link (A).
3. Install the chain on the gear wheels. Check that the wheels are straight and that the middle marked link is positioned at the centre of the chain gear wheel, if this is not the case, take to the straight position.
4. Install the two front pulleys (B) with the cables connected to the steering chain. Lock the pulleys in place with the two circlips (C).
5. Insert the cables in the two rear pulleys (D) and tighten the bolt (E), so that the cables can slip out.
6. Thread the cables through the two holes (F) on the rear frame.
7. Adjust the cables  [3.1.3](#)

### 3.1.3 Adjustment

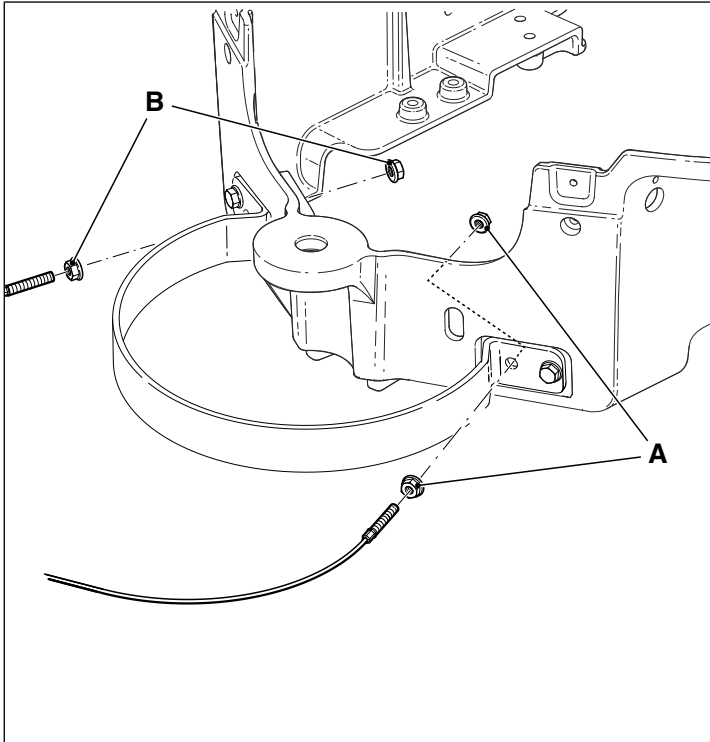

1. Adjust the nuts (A and B) on the two cable ends to eliminate any play.

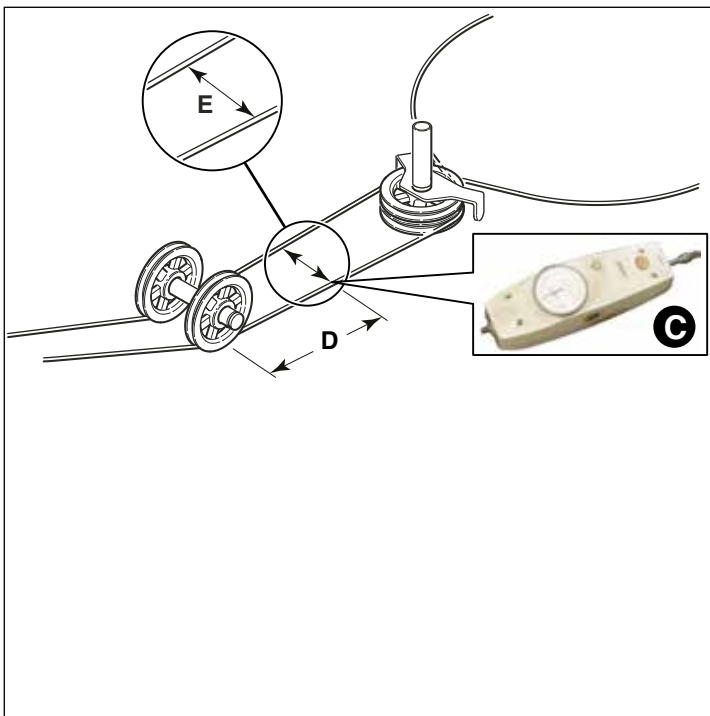

2. Make sure the cables are adequately tensioned. Use a dynamometer. Attach the dynamometer (C) to the cable at 10 cm (measurement D) from the front pulley.
3. Apply a force of 5 - 7 kg. The distance (E) between the cables should be approximately 45 mm.
4. Test drive the machine with the wheels straight and check that the steering wheel is in the right position.
5. If the steering wheel is turned, slacken first one nut and tighten the other (A or B) by the same value. Repeat the procedure until the steering wheel is in the right position. Tension the nuts on the cables on both sides so that the wheels are straight when the machine is also straight.

### 3.1.4 Replacing the bushes on the steering shaft

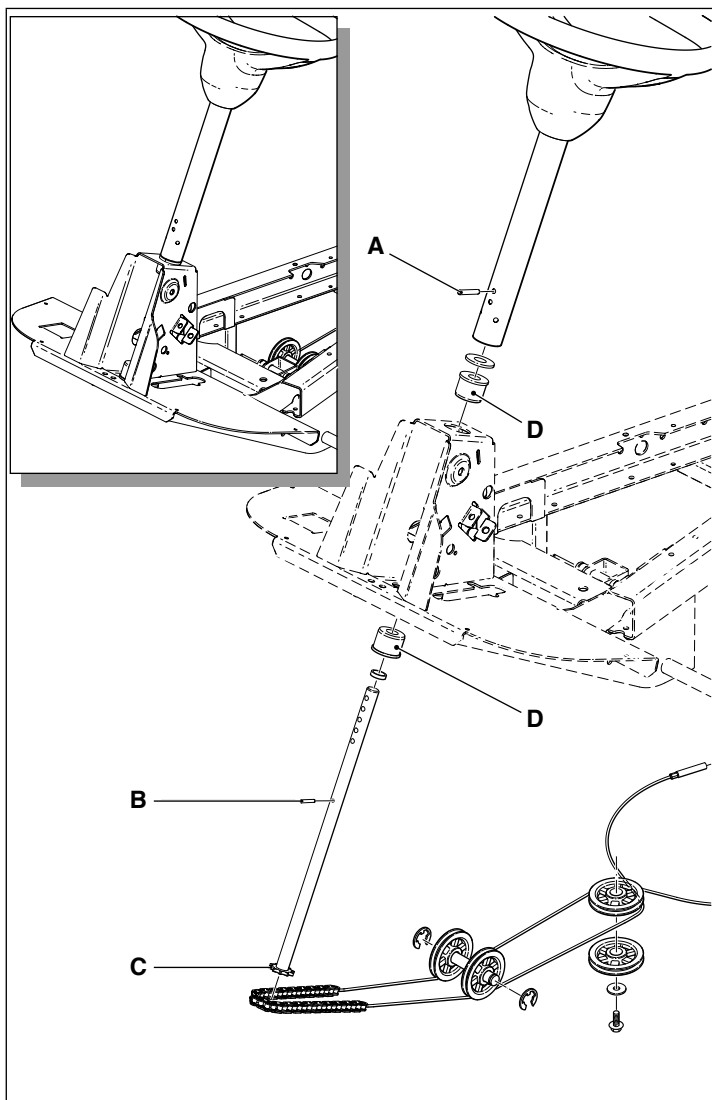

1. Remove the steering wheel: remove the pin (A).
2. Remove the steering chain and cables.  
For further details see [3.1.1](#)
3. Remove the front covers;  
For the relative description, see [2.1.3](#)
4. Remove the pin (B).
5. Take hold of the gearwheel (C) on the bottom of the steering shaft and remove it.
6. Remove the damaged bushes (D).

Follow the instructions in reverse order to reassemble.

## 4 Hydraulic system

### Table of contents

<b>4.1 Safety</b> .....	<b>29</b>
<b>4.2 Description</b> .....	<b>29</b>
<b>4.3 Repair</b> .....	<b>29</b>
<b>4.4 HST oil</b> .....	<b>29</b>
4.4.1 General.....	29
4.4.2 Oil change .....	30
<b>4.5 Transmission removal</b> .....	<b>30</b>
<b>4.6 Changing engine oil</b> .....	<b>30</b>
4.6.1 Checking the engine oil level.....	30

This chapter contains a brief description of the hydrostatic transmission and the oil filling procedure.

Abbreviations used in this chapter:  
HST = Hydrostatic Transmission.



## 4.1 Safety

### Caution!!!



A high level of cleanliness is mandatory when carrying out all operations on the hydraulic system. Foreign objects and contaminants would jeopardize system operation and reliability. Always protect and plug the ends of pipes, lines and connectors when replacing components.

## 4.2 Description

The hydrostatic transmission (HST) consists of a hydraulic pump and a hydraulic motor. The hydraulic pump is mechanic connected to the drive belt. The power from the pump is transmitted to the motor by an oil flow.

Since both the oil flow and the flow direction is controlled by the drive pedal, the machine can move both forwards and backwards with a stepless gear ratio.

## 4.3 Repair

Since trouble with the HST is very rare. There for it is no need for any repair instructions in this book.

Oil leakage can occur for various reasons. Therefore it is described on next page how oil can be filled.

Should major repair to the HST be needed, please refer to the service provided of the transmission manufacturer.

## 4.4 HST oil

### 4.4.1 General

It is recommended that oil filling should only be performed if one or both of the following conditions are met:

- There is a visible oil leakage.
- Traction problems.

	U.M.	PARK 300 M	PARK 300
<b>Oil</b>		10W-30	
<b>Volume</b>	ml	1200	

#### 4.4.2 Oil change

To change/top up the transmission fluid must remove the transmission (👉 4.5) and refer to the instructions provided by the manufacturer.

### 4.5 Transmission removal

Transmission disassembly

1. Remove the HST cable. 👉 6.3.1
2. Remove the brake cable. 👉 6.4.1.
3. Remove the belt "D". 👉 5.2.2.
4. Lift the machine from the rear side just enough so that the front wheels do not touch the ground. Keep it lifted using a jack or strong wooden planks.

#### Warning!



Check that the machine is supported effectively and safely.

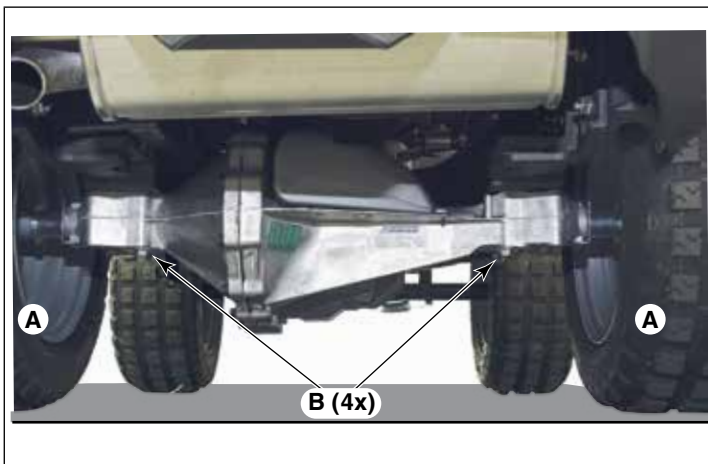

5. Remove the rear wheels (A).
6. Unscrew the 4 screws (4) which hold the transmission in place.

To reassemble the various parts, repeat the operations in reverse order.

### 4.6 Changing engine oil

Change engine oil for the first time after 5 hours of operation, and subsequently after every 50 hours of operation or once a season.

For instructions on how to change the engine oil please refer to the instructions provided by the manufacturer and see the "INSTRUCTION MANUAL".

#### 4.6.1 Checking the engine oil level

For instructions on how to check the engine oil level see the "INSTRUCTION MANUAL".

# 5 Belts

## Table of contents

<b>5.1 Theory on the use of belts</b> .....	<b>32</b>
5.1.1 Why is it so important to use genuine belts supplied by authorized vendors?	32
<b>5.2 Description</b> .....	<b>34</b>
5.2.2 Drive belts (D).....	35
5.2.3 Operating equipment (C) clutch belt.....	36
5.2.4 Operating equipment belt (B). .....	40

All the mechanical power provided by the engine is transmitted to the various power users by a belt system. The maximum tension of each belt is adjusted by a tensioner with pre-load spring.



This chapter provides a brief description of the belt system and includes brief belt replacement procedures.

## 5.1 Theory on the use of belts

### 5.1.1 Why is it so important to use genuine belts supplied by authorized vendors?

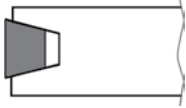
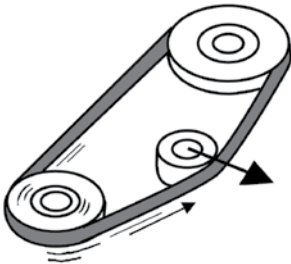
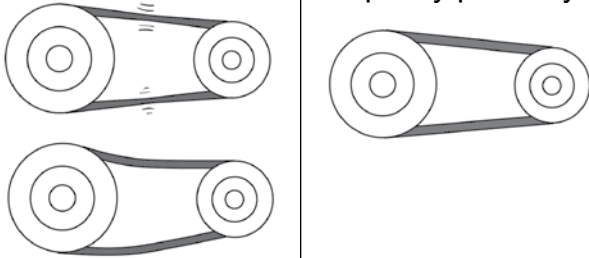
The table below shows the specifications for commercially available belts compared to the requisites of genuine belts supplied by an authorized vendor. The latter are designed and made with close collaboration between the belt supplier and the machine manufacturer. The table is to help you understand the importance of using genuine belts.

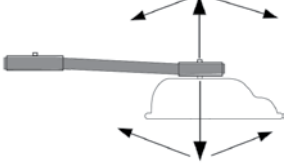
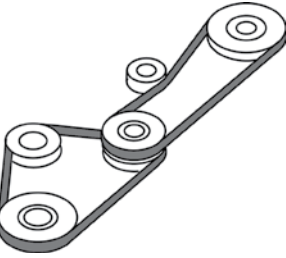
Example	Commercially available belts	Genuine spare belts	Notes
Fitting on the pulley. 	The belt rests its sloping sides against the walls of the pulley. There must be a gap between the belt and the bottom of the groove.	The belt rests its sloping sides against the walls of the pulley. There must be a gap between the belt and the bottom of the groove.	Same requirements. Genuine spare belts ensure a perfect fit on the pulley.
Acceleration. 	Some belts slot into the pulleys only when the engine is running at operating speed and this generates excessive heat.	The belt follows the engine speed in continuous acceleration until the maximum speed is reached.	Ordinary belts are made from natural rubber which can only withstand temperatures of up to 70°C. Genuine spare belts are made from chloroprene rubber which can withstand temperatures of up to 90°C.
Length 	Made with standard length pitch.	Made to a specified length designed to fit the pulley perfectly.	The distance between pulleys is fixed. The tensioner ensures that the genuine belt has the optimum tension.

Example	Commercially available belts	Genuine spare belts	Notes
<p>Floating pulley on the cutting equipment.</p> 	<p>Designed to transmit the power between aligned, parallel and fixed pulleys.</p>	<p>The genuine belt of the PTO is designed to function even if the pulleys move up and down and tilt simultaneously.</p>	<p>The equipment follows the ground which means that the pulley is in constant movement. To withstand extreme operating conditions, genuine belts are made from fibre reinforced rubber.</p>
<p>Bending in two directions.</p> 	<p>Designed to bend around the pulley in one direction only.</p>	<p>Most belts installed on machines have tensioning rollers which act on the outer side of the belt. This means that during operation the belt must bend both inwards and outwards.</p>	<p>All genuine belts, which operate with tensioning rollers acting on the outer side, are fitted with reinforcement. The reinforcement is designed specifically for these specific cases.</p>
<p>Noise.</p> 	<p>Made with no special requisite for this specific factor.</p>	<p>Genuine belts are carefully selected to limit increases in machine noise during operation.</p>	<p>Based on the function of the belt, any of the following types of belt are suitable:</p> <ul style="list-style-type: none"> <li>• Coated</li> <li>• No friction</li> <li>• Open-sided</li> </ul>

## 5.2 Description

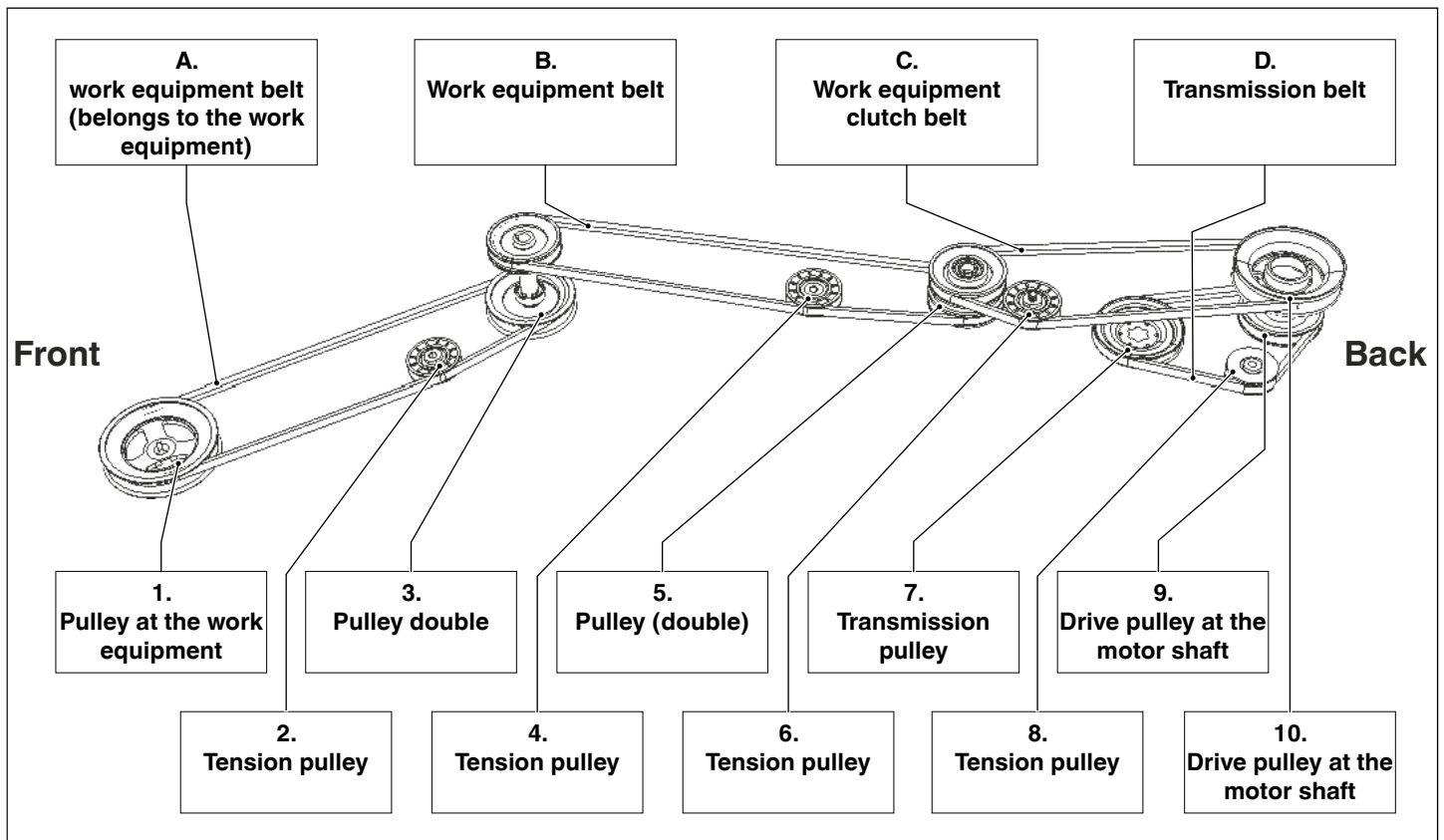

### Belt A

The belt A belongs to the operating equipment and is connected to the machine by means of a double front pulley (3). The belt is kept tensioned by the tensioning pulley (2) installed on a spring-loaded tensioning arm.

### Belt B

Belt B is dedicated to transmission from the articulated point to the double front pulley which provides power to the operating equipment. The belt is kept tensioned by the tensioning pulley (4) installed on a spring-loaded lever.

### Belt C

Belt C transmits power to belt C and performs the function of PTO clutch. The belt is kept tensioned by the tensioning pulley (6) installed on a spring-loaded lever.

### Belt D

Belt D is for transmitting power from the engine to the transmission which transforms it into a suitable power ratio for the drive shaft. The belt is kept tensioned by the tensioning pulley (8) installed on a spring-loaded lever.

## 5.2.2 Drive belts (D)

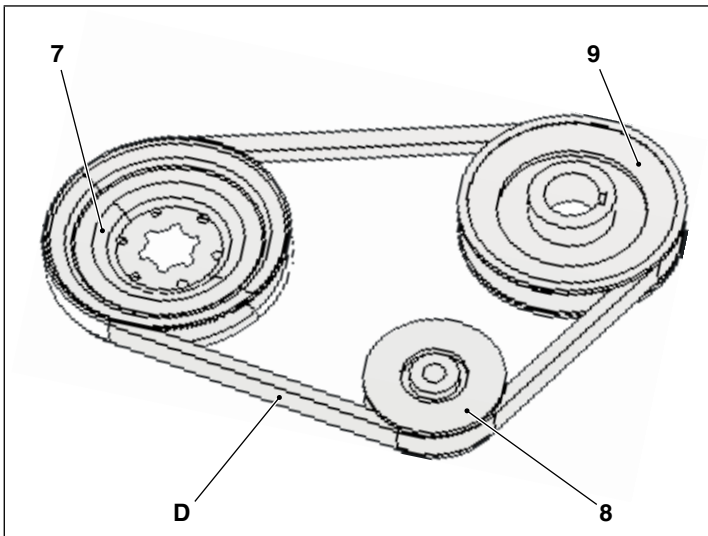

For greater understanding on how the belts are positioned, see [5.2](#).

### Disassembly

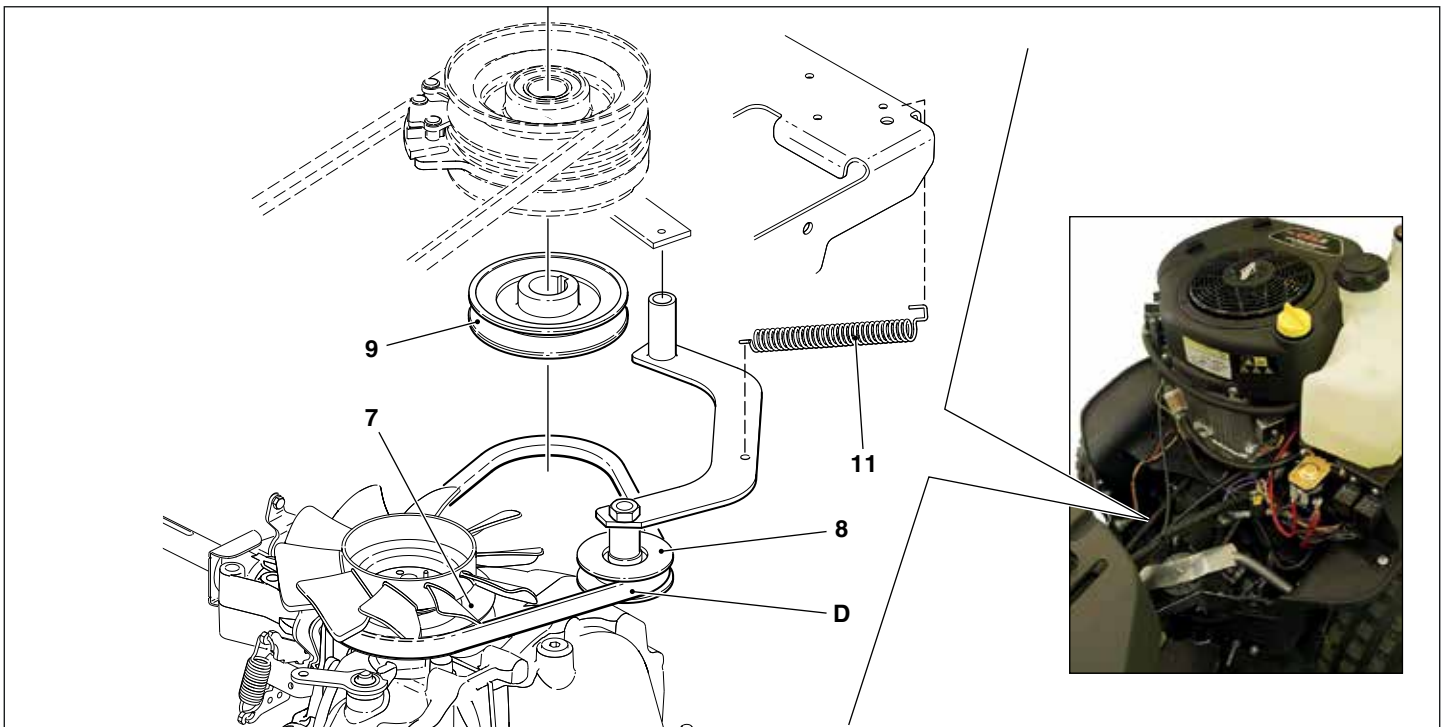



1. Remove the engine casing [2.1.1](#).
2. Remove the spring (11) from the tensioning arm.
3. Slip the belt (D) off the pulley (9) connected to the drive shaft.
4. Remove the belt (D) from the pulley (7) and extract it upwards (over the top of the fan).

### Assembly

1. Install the belt (D) from the front side, onto the pulley (7).
2. Pull the belt and fit it around the tensioning pulley (8) and wind it around the pulley (9) on the drive shaft. Please note that the tensioning pulley must be positioned on the inside of the belt.
3. Replace the spring (11) on the tensioning arm.
4. Replace the engine casing [2.1.1](#).

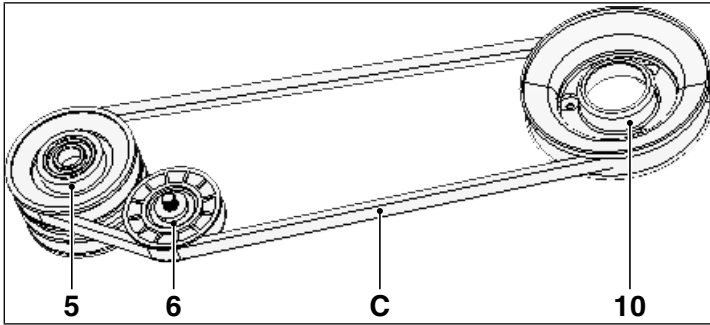

### 5.2.3 Operating equipment (C) clutch belt.

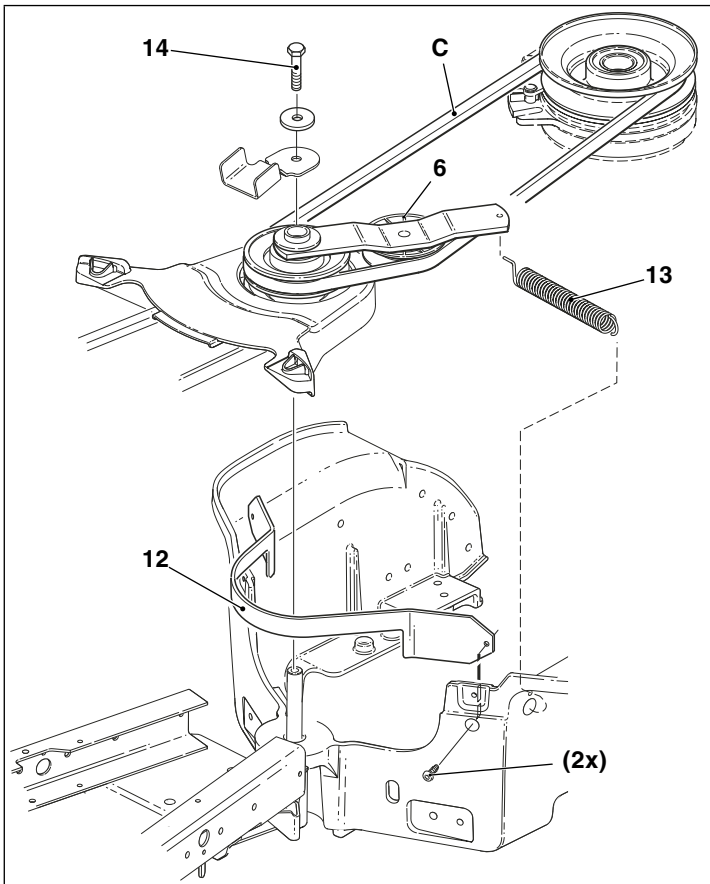

For greater understanding on how the belts are positioned, see  [5.2](#).

#### Disassembly



1. Remove the engine casing  [2.1.1](#)
2. Remove the belt (D) from the transmission  [5.2.2](#).
3. Remove the upper belt casing (12), two screws.
4. Remove the spring (13) from the tensioning arm on which the tensioning pulley (6) is installed.
5. Unscrew the central top bolt (14) and move the tensioning arm sideways.



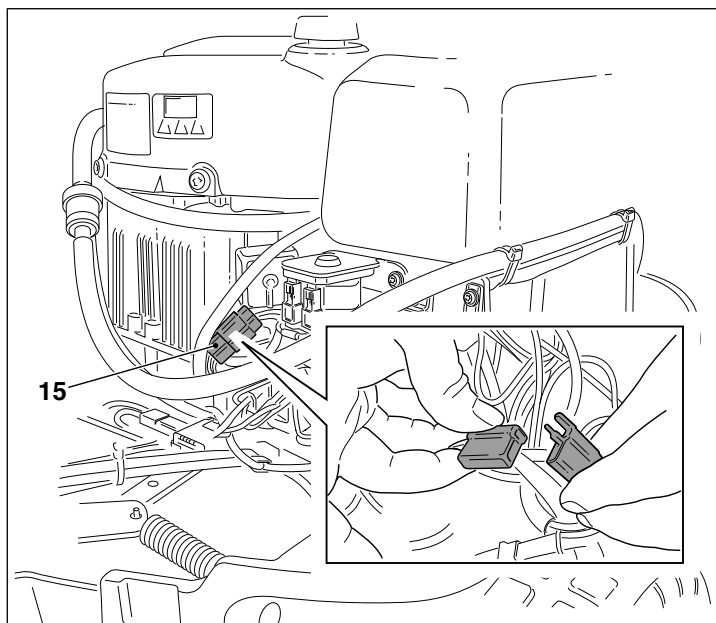

6. Cut the tie which holds the cable to the clutch.
7. Disconnect the connector (15) from the clutch cable.

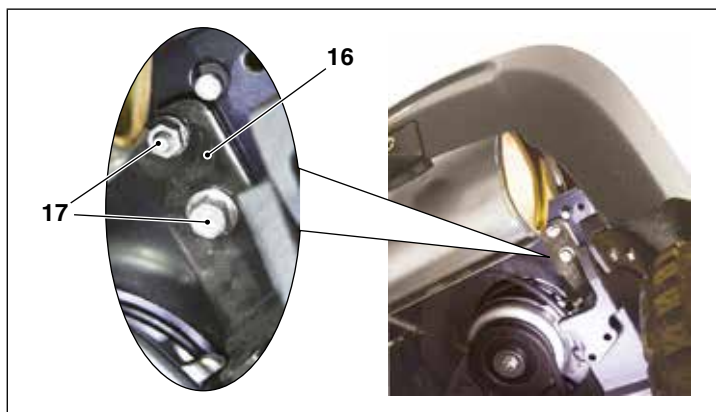

8. Remove the clutch stopper (16) by unscrewing the two screws (17).

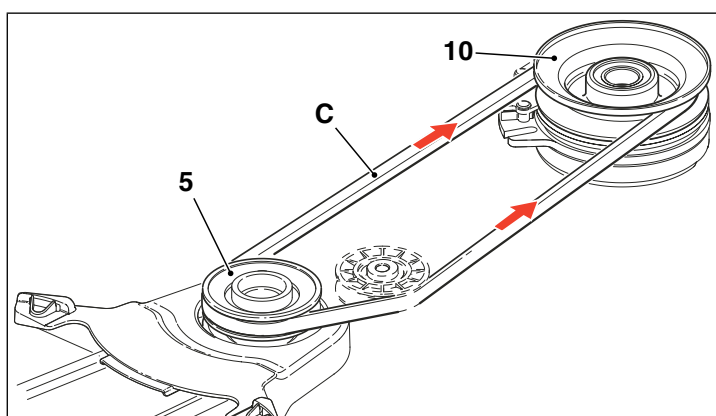

9. Remove the belt from the double pulley (5).
10. Remove the belt (C) from the pulley (10) on the drive shaft and slip the belt out from the rear.

## Assembly

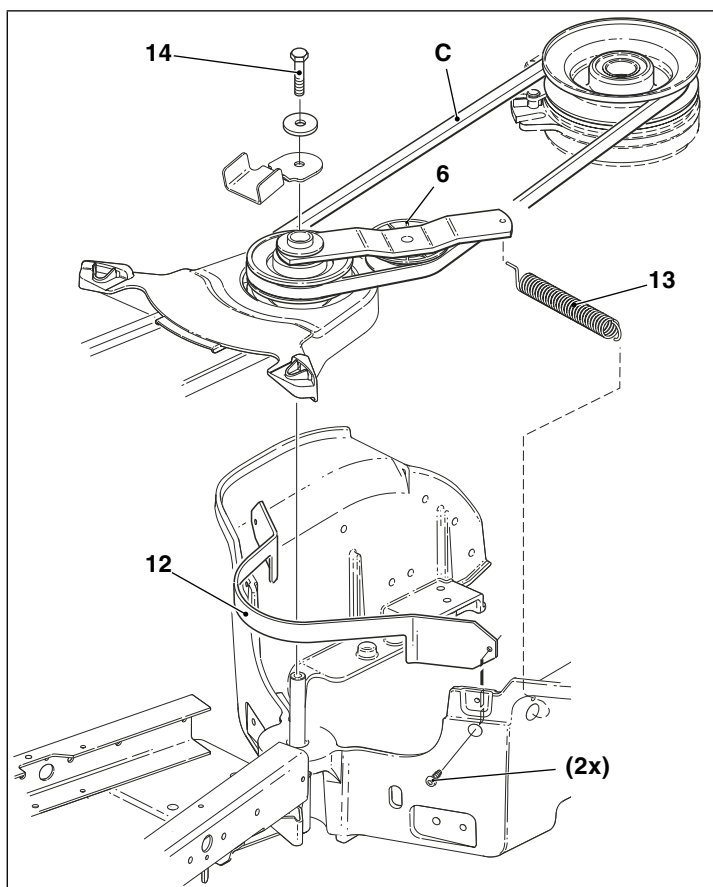

1. Insert the belt (C), from the front side, in the groove on the double pulley and then fitting it on the drive shaft pulley.
2. Replace the upper belt casing (12), two screws.

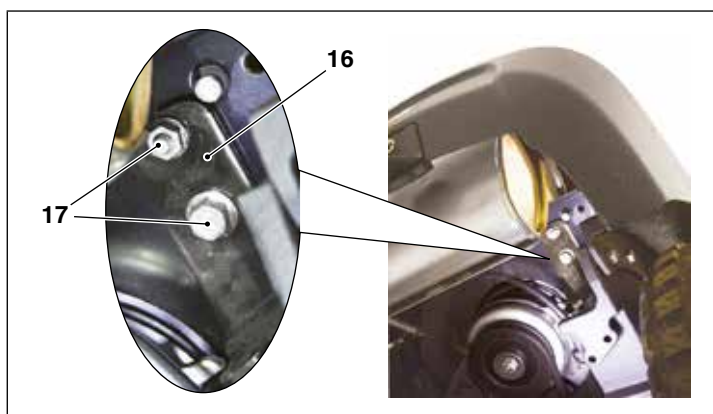

3. Replace the magnetic clutch stopped (16) using the screws (17).

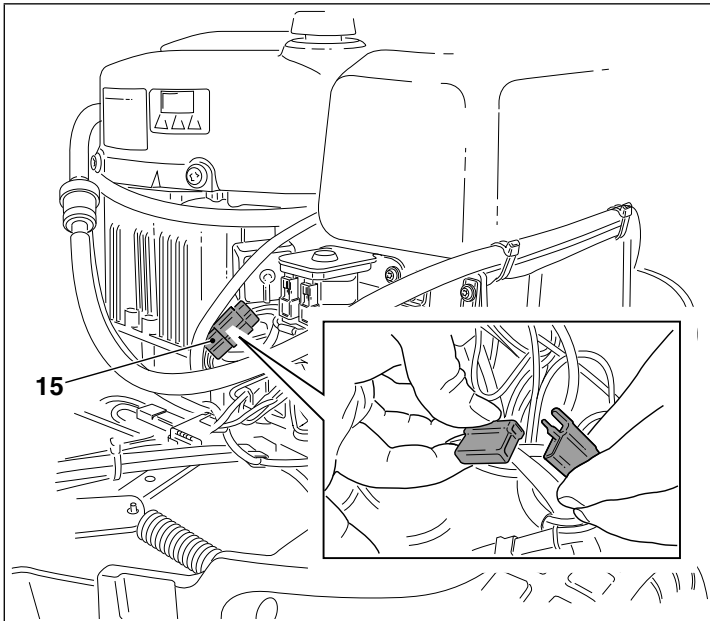

4. Connect the cable (15) to the magnetic join and fasten the cable in place with the cable tie.
5. Fit the belt (D).  [5.2.2](#).

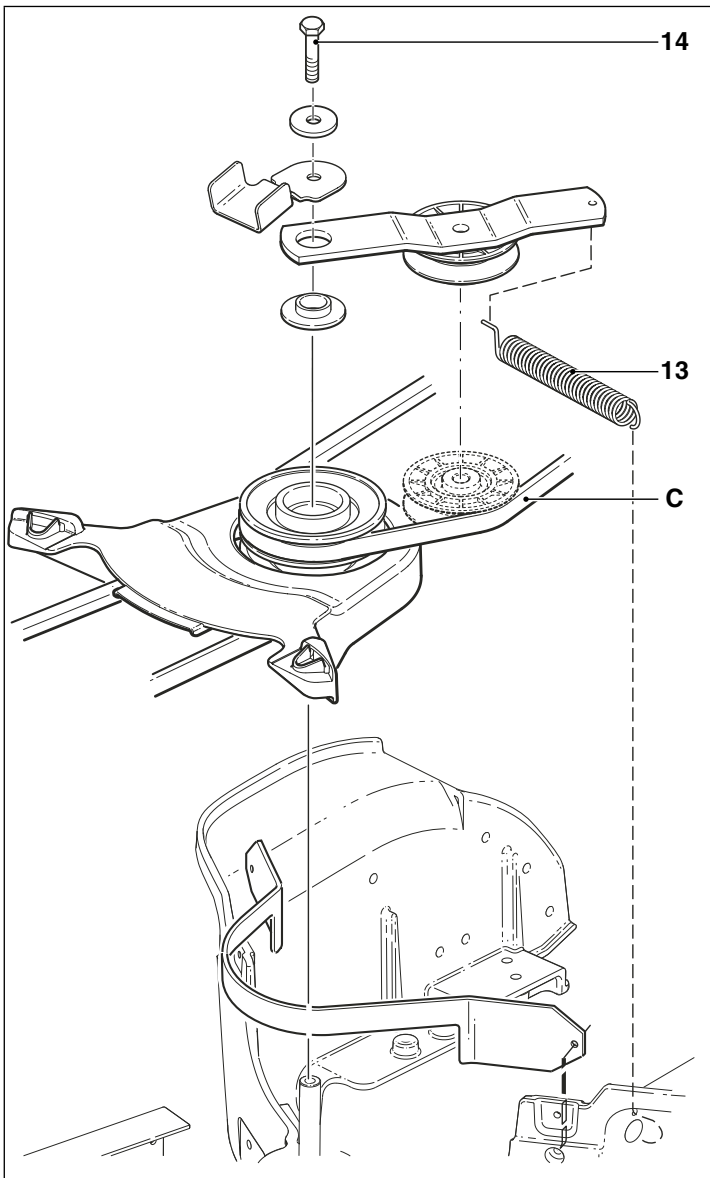

6. Install and tighten the central top bolt (14) and the tensioning arm on the belt (C). Please note that the tensioning pulley must be positioned on the inside of the belt.
7. Install the spring (13). The spring is connected to the tensioning arm from the bottom end, once inserted, turn the opposite end clockwise by half a turn and connect it to the frame.
8. Install the engine casing  [2.1.1](#).

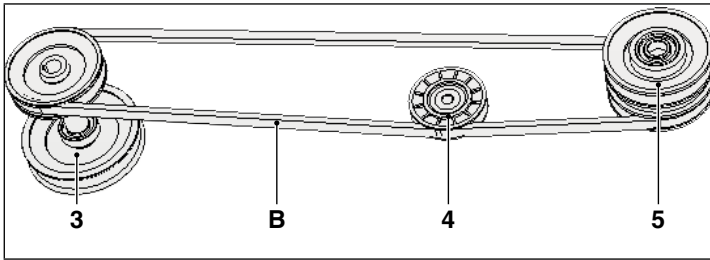
**5.2.4 Operating equipment belt (B).**

For greater understanding on how the belts are positioned, see  [5.2](#).

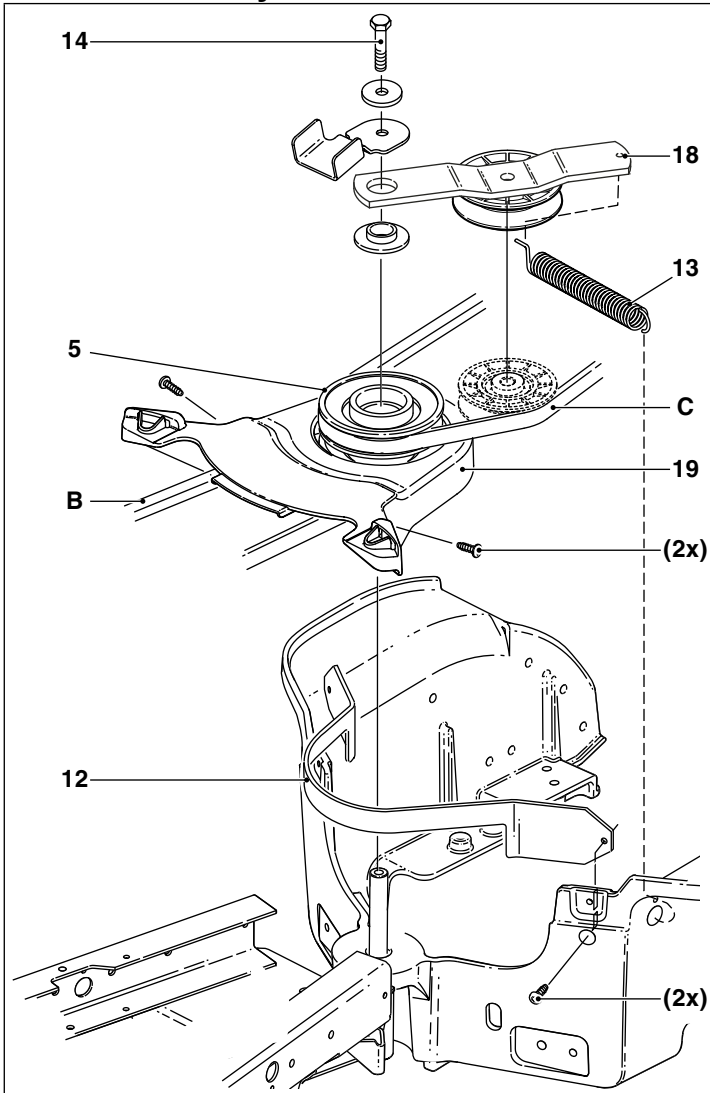
**Disassembly**

1. Remove the engine casing  [2.1.1](#)
2. Remove the spring (13) on the tensioning arm which is dedicated to the equipment clutch belt (C).
3. Unscrew the central top bolt (14) and move the tensioning arm (18) sideways.
4. Remove the upper belt casing (19), two screws.
5. Slip the belt (C) off the double pulley (5) from the central point.
6. Remove the bottom belt casing (12), two screws.

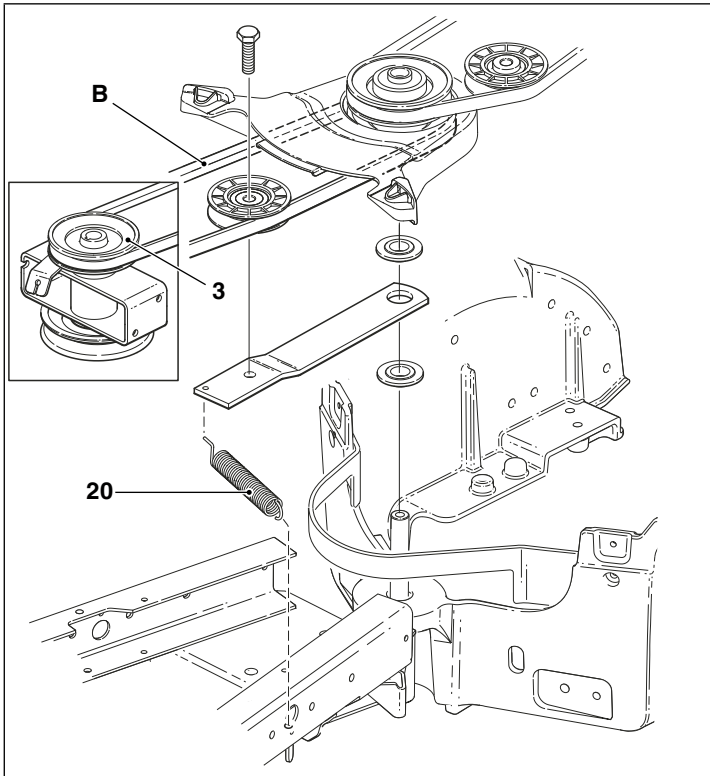

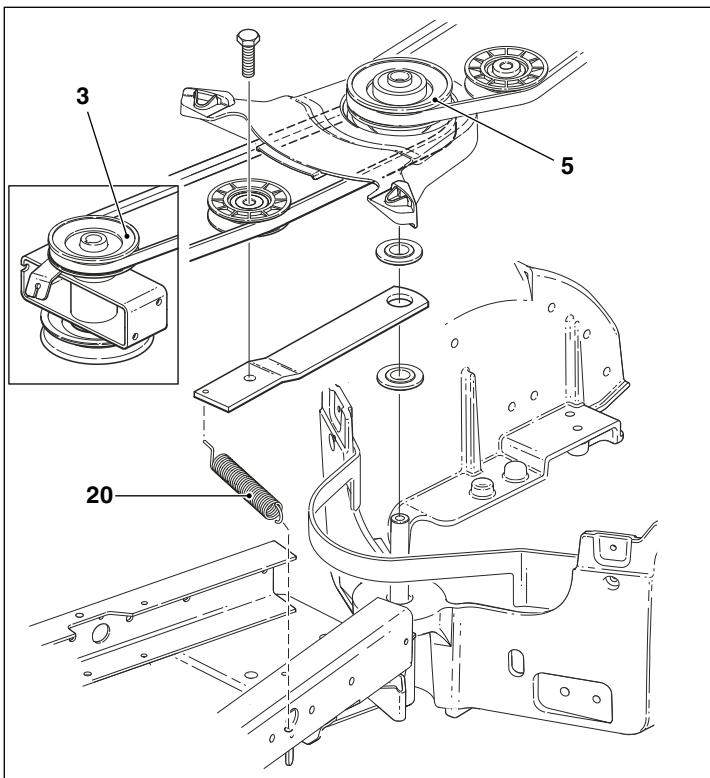

7. Remove the spring (20) on the tensioning arm which is dedicated to the equipment belt (B).
8. Pull the double pulley from the centre upwards and then slip off the belt (B).
9. Slip the belt off the front double pulley (3).

### Assembly

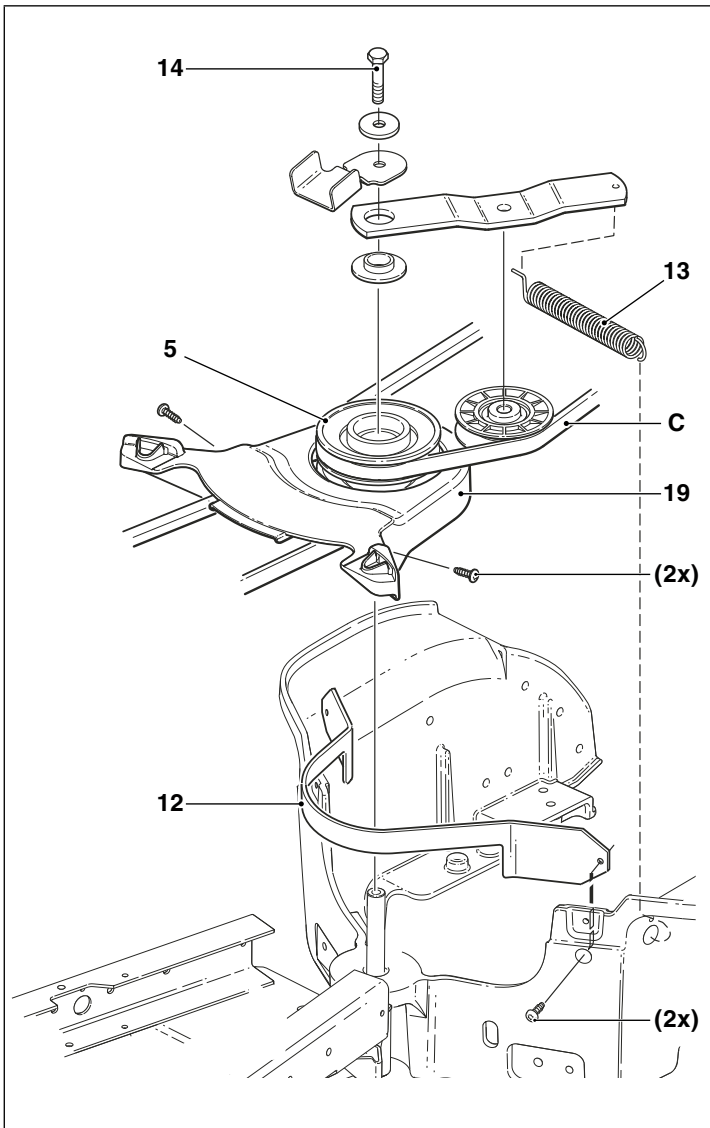

1. Insert the belt from the front and start by fitting it in the top groove (3) of the double pulley.
2. Then fit the belt on the double pulley (5) from the central point.
3. Install the spring (20). The spring is connected to the tensioning arm from the bottom side and must be connected to the frame.



4. Replace the bottom belt casing (12), two screws.
5. Centrally install the belt (C) for the operating equipment clutch on the double pulley (3).
6. Replace the upper belt casing (19), two screws.
7. Install and tighten the central top bolt (14) and the tensioning arm on the belt (C). Please note that the tensioning pulley must be positioned on the inside of the belt.
8. Install the spring (13). The spring is connected to the tensioning arm from the bottom end, once inserted, turn the opposite end clockwise by half a turn and connect it to the frame. See the figure.
9. Replace the engine casing  [2.1.1](#)

# 6 Control cables

## Table of contents

<b>6.1 Description .....</b>	<b>44</b>
6.1.1 General Information .....	44
6.1.2 Cable ties .....	44
<b>6.2 Angle ball joints .....</b>	<b>45</b>
<b>6.3 HST control cable .....</b>	<b>46</b>
6.3.1 Disassembly .....	46
6.3.2 Assembly .....	46
6.3.3 Adjustment .....	47
<b>6.4 Brake cable .....</b>	<b>47</b>
6.4.1 Disassembly .....	47
6.4.2 Assembly .....	48
6.4.3 Adjustment .....	48
<b>6.5 Accelerator cable .....</b>	<b>49</b>
6.5.1 Disassembly .....	49
6.5.2 Assembly .....	49
6.5.3 Adjustment .....	50

## General description

All mechanical control commands given by the operator and sent to the various devices are via sheath coated wires or, in some cases connector rods.

This chapter gives a brief description of these parts and lists all necessary repair and replacement procedures.

## 6.1 Description

### 6.1.1 General Information

All cables are made up of a wire and a sheath. One cable end is connected to the actuator, (pump, carburettor etc.) the other end is connected to the control (pedal lever). In most cases the cable ends are equipped with adjusting terminals with locking nuts and/or elbow unions.

The cables can only transmit traction force. The return force is generated by the springs.

For a higher transmission of pushing and traction forces, components such as levers, brackets, etc. are used.

#### Cable maintenance:

Cables only need to be lubricated.

### 6.1.2 Cable ties

All cables are installed and fastened to the frame using cable ties. When cables are removed or replaced, you must install new cable ties in the original positions.

#### **Attention!**



Loose cables can cause unnecessary wear to the components. This can cause damage to plastic protection, paint damage, etc.



## 6.2 Angle ball joints

The angle ball joints perform two functions:

- Transmit movement from the control to the actuator.
- Adjust cable tension.

**Note!** On the adjustment point, at least 5 threads should be used.

### Change

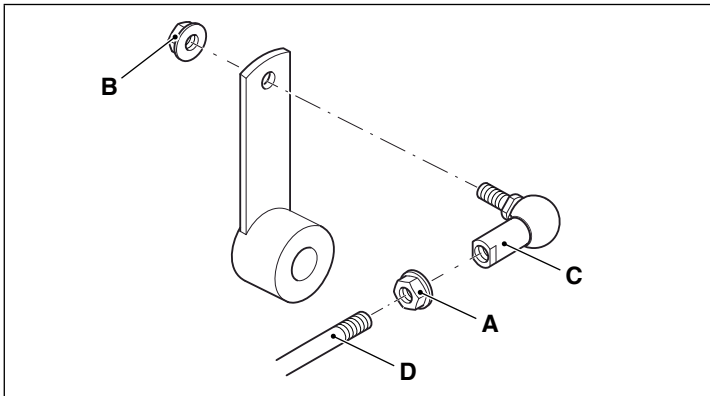

1. Tighten nut (A).
2. Unscrew the nut (B).
3. Unscrew the ball joint (C) from cable (D).
4. To reassemble the various parts, repeat the operations in reverse order.
5. Once assembly is complete, adjust the cable tension.

### Disassembly

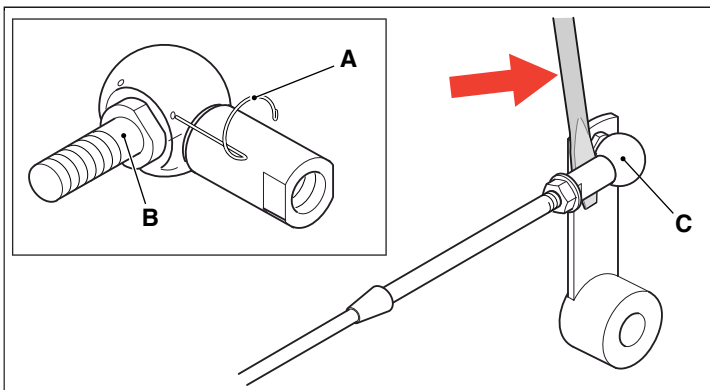

1. Remove the circlip (A).
2. Using a screwdriver or similar tool, remove the ball pin (B) from its seat (C).
3. To reassemble the various parts, repeat the operations in reverse order. The ball pin (B) must be inserted into its seat (C) using a poly-grip pliers or similar tool.

### Adjustment

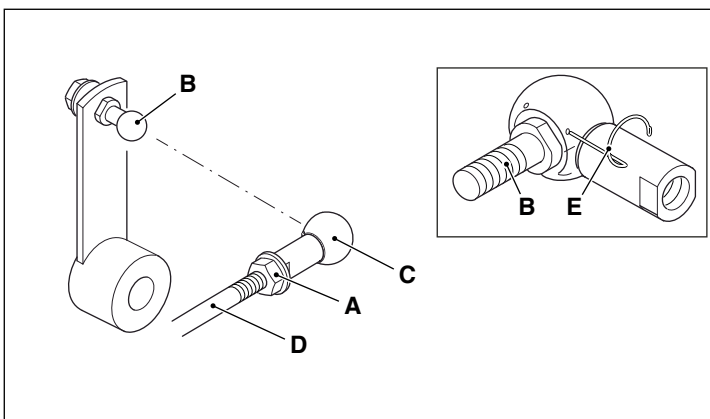

1. Tighten nut (A).
2. Separate the ball pin (B) from the ball joint (C).  
➡ **“Disassembly”**
3. Screw / unscrew the seat of the angle ball joint (C) on the cable (D).
4. Check the adjustment result by installing the ball joint (C) on the ball pin (B) without inserting the circlip (E).
5. Once the adjustment is correct, insert the circlip (E).
6. Tighten nut (A).

### Danger!



To prevent the ball pin from falling apart during operation, it is important that circlip (C) is inserted in both holes on the angle ball joint seat.

## 6.3 HST control cable

### 6.3.1 Disassembly

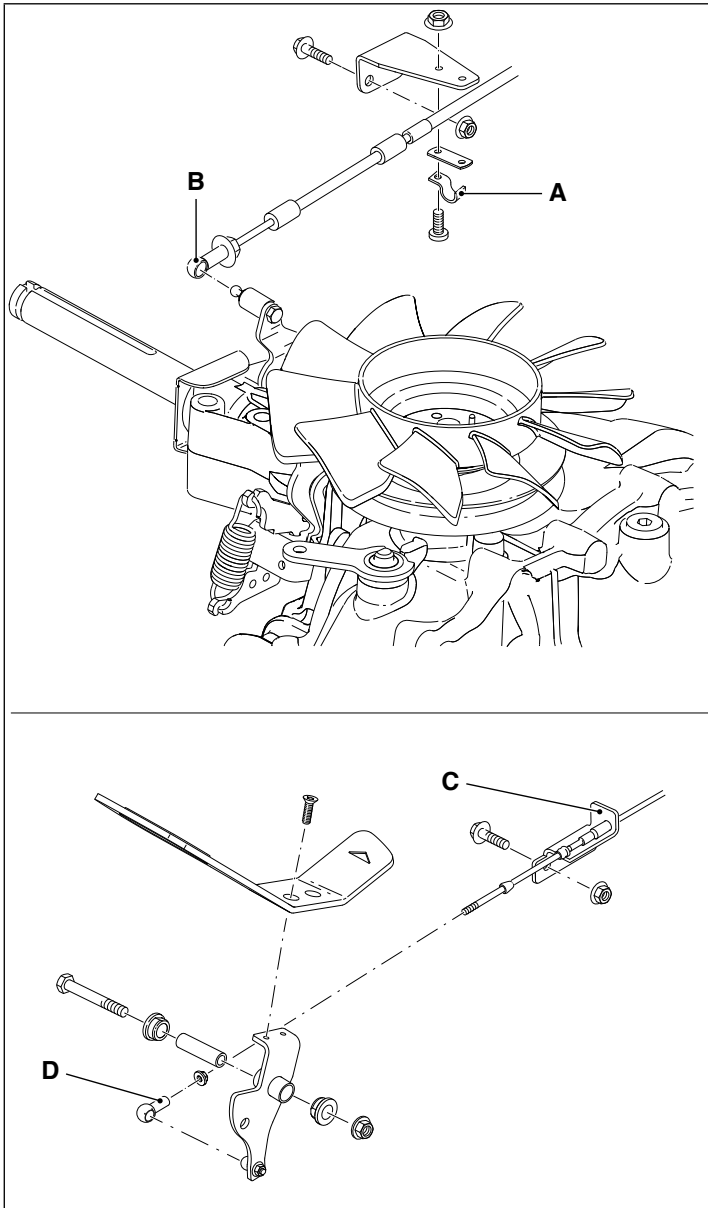



1. Remove the engine casing.  [2.1.1](#)
2. Detach the cable from the bracket (A) and the body of the elbow connector (B) from the ball on the transmission.
3. Detach the cable from the bracket (C) and the body of the elbow connector (D) from the ball on the pedal bracket.
4. Remove all the cable ties. Make a note of how the cables and cables ties are connected to ensure that the new components are reinstalled in exactly the same way.
5. Remove the elbow connectors from the cable.

#### Caution!



The bodies of the elbow connectors need to be reused in the reassembly stage.

### 6.3.2 Assembly

1. Pour some oil drops on the two cable terminals and move the wire a few times inside its sheath.
2. Feed the cable inside starting from the machine rear side.  
(The arrow printed on the cable points to the front of the machine).
3. Check the angle ball joints, replace them if worn or damaged, special instructions shall be observed  [6.2](#).
4. Adjusting the cable  [6.3.3](#).

### 6.3.3 Adjustment

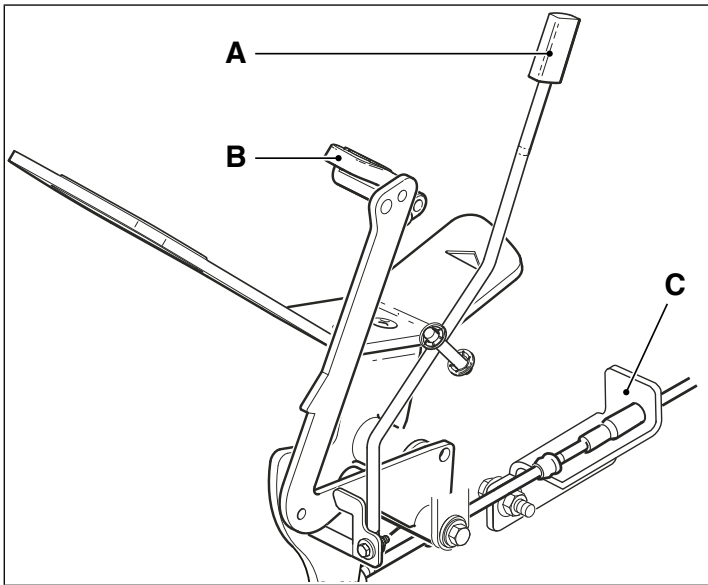

1. Block the parking brake by moving the lever (A) to the left once the parking brake (B) has been engaged.
2. Then adjust the bracket (C) forward or backward so that the cable neither pushes or pulls the pedal forward/backwards.
3. If necessary, adjust the rear elbow connector located on the pump.

### 6.4 Brake cable

#### Danger!



NEVER use the machine if the brakes are faulty.

#### Caution!



The parking brake must not be used as an operating brake and must only be engaged when the machine is already stationary. Incorrect use may damage the components.

#### 6.4.1 Disassembly

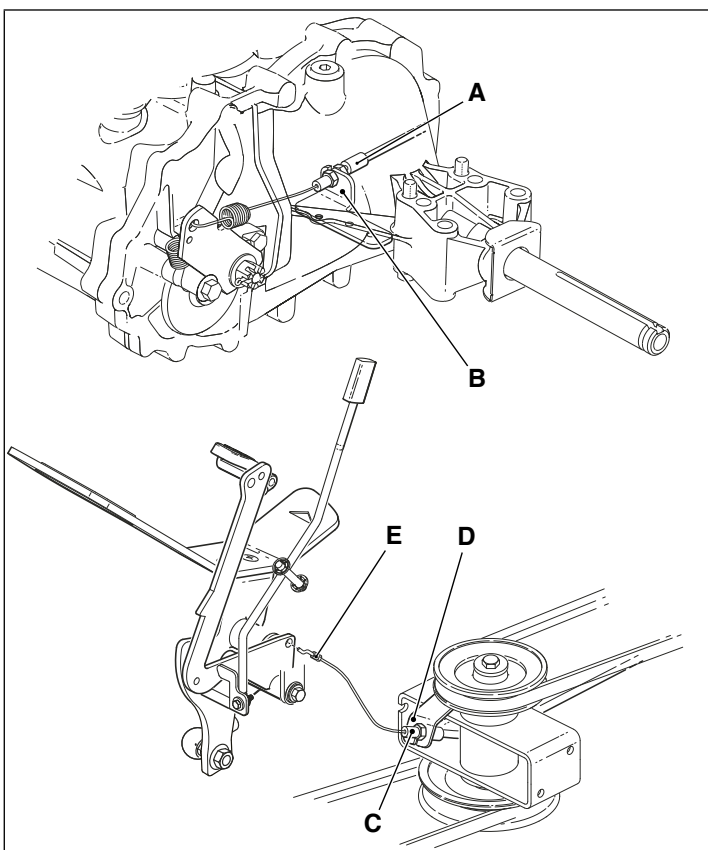

1. Remove the tie which hold the cable in place.
2. Remove the cable (A) from the bracket (B).
3. Remove the cable (C) from the bracket (D).
4. Detach the end (E) from the parking brake.
5. Completely extract the cable.

## 6.4.2 Assembly

1. Pour some oil drops on the two cable terminals and move the wire a few times inside its sheath.
2. Follow the instructions in reverse order to reassemble.
3. Install new cable ties.
4. Adjusting the cable  [6.4.3](#)

## 6.4.3 Adjustment

### Danger!



**NEVER use a machine with faulty brakes!**

### Caution!





Check that the cables are slack when the parking brake is not engaged.  
Incorrect adjustment will result in greater wear on the brakes.

Adjust the cable on the front and rear registers to achieve minimum play.  
Then check that the parking brake works correctly.  
Perform further adjustment if necessary.

## 6.5 Accelerator cable

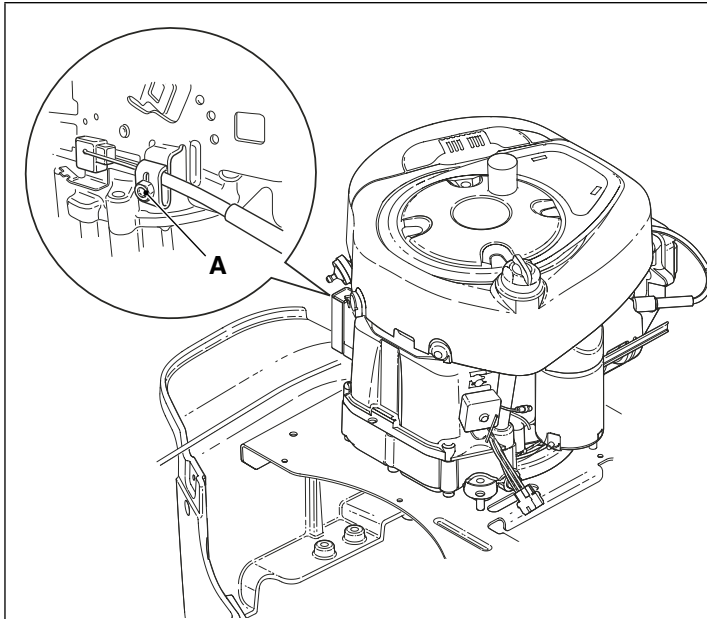
### 6.5.1 Disassembly



1. Remove the engine casing  [2.1.1](#)
2. Release the cable (A) from the engine.
3. Pull the cable unit through the centre of the machine, passing it under the seat.

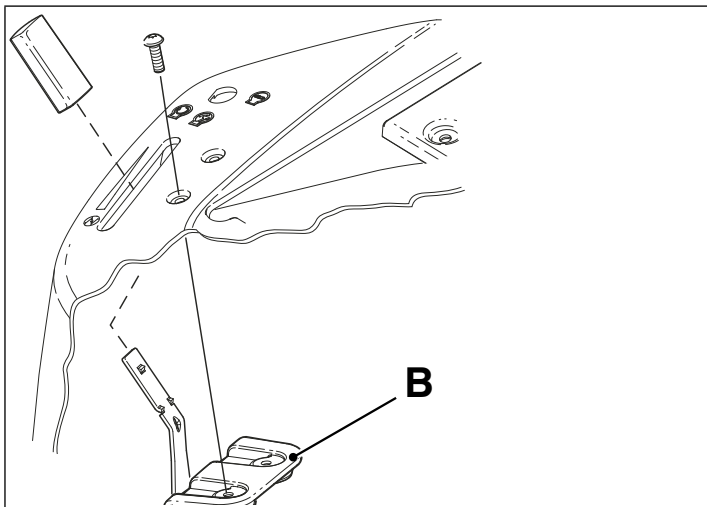

4. Disassemble the accelerator control (B).
5. Pull the accelerator control back and the cable until it comes out from under the plastic cover.
6. Detach the cable unit from the accelerator control.

### 6.5.2 Assembly

1. Pour some oil drops on the two cable terminals and move the wire a few times inside its sheath.
2. Route the cable through the same previous cable path.
3. Mount the new fixing clamps in the exact point of the previous ones.
4. Adjusting the cable  [6.5.3](#)

### 6.5.3 Adjustment

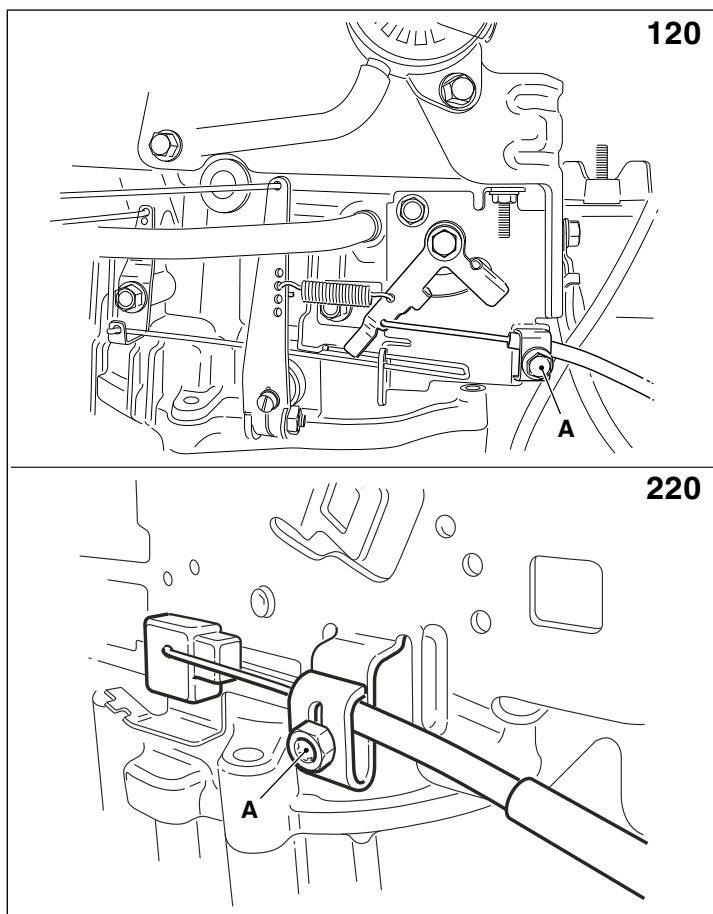

1. Adjust the cable sheaths on the terminals until the accelerator lever reaches the end of stroke position.
  2. Tighten the clamps (A) of the sheaths.
  3. Check the following:
    - Operation of the choke position.
    - The maximum acceleration position.
- If necessary repeat the adjusting procedure.

# 7 Electrical system

## Table of contents

<b>7.1 Description .....</b>	<b>52</b>
7.1.1 Cable holders .....	52
<b>7.2 Troubleshooting.....</b>	<b>53</b>
<b>7.3 Electric cables .....</b>	<b>57</b>
7.3.1 Description.....	57
7.3.2 Cables PARK 300 M.....	58
7.3.3 Cables PARK 300.....	59
<b>7.4 Repair and replacement .....</b>	<b>60</b>
7.4.1 Relay positions .....	60
7.4.2 Replacing the fuse.....	61
7.4.3 Replacing switches.....	62
7.4.4 Replacing switch controls.....	62
7.4.5 Connections.....	63
7.4.6 Removing the battery .....	63
<b>7.5 Control panels.....</b>	<b>64</b>
<b>7.6 Wiring diagram.....</b>	<b>65</b>

## General description

The electrical system has two primary functions. To maintain the machine's safety systems and facilitate certain functions.

The main part of this chapter will describe how to troubleshoot the electrical system. The schedules for the troubleshooting are intended to assist in establishing electrical faults, in order to then take the correct action. This also describes common repairs and procedures for replacing certain components.

## 7.1 Description

The cables are connected to the actual components with tab or screw connectors and in some cases with multi-contact connectors.

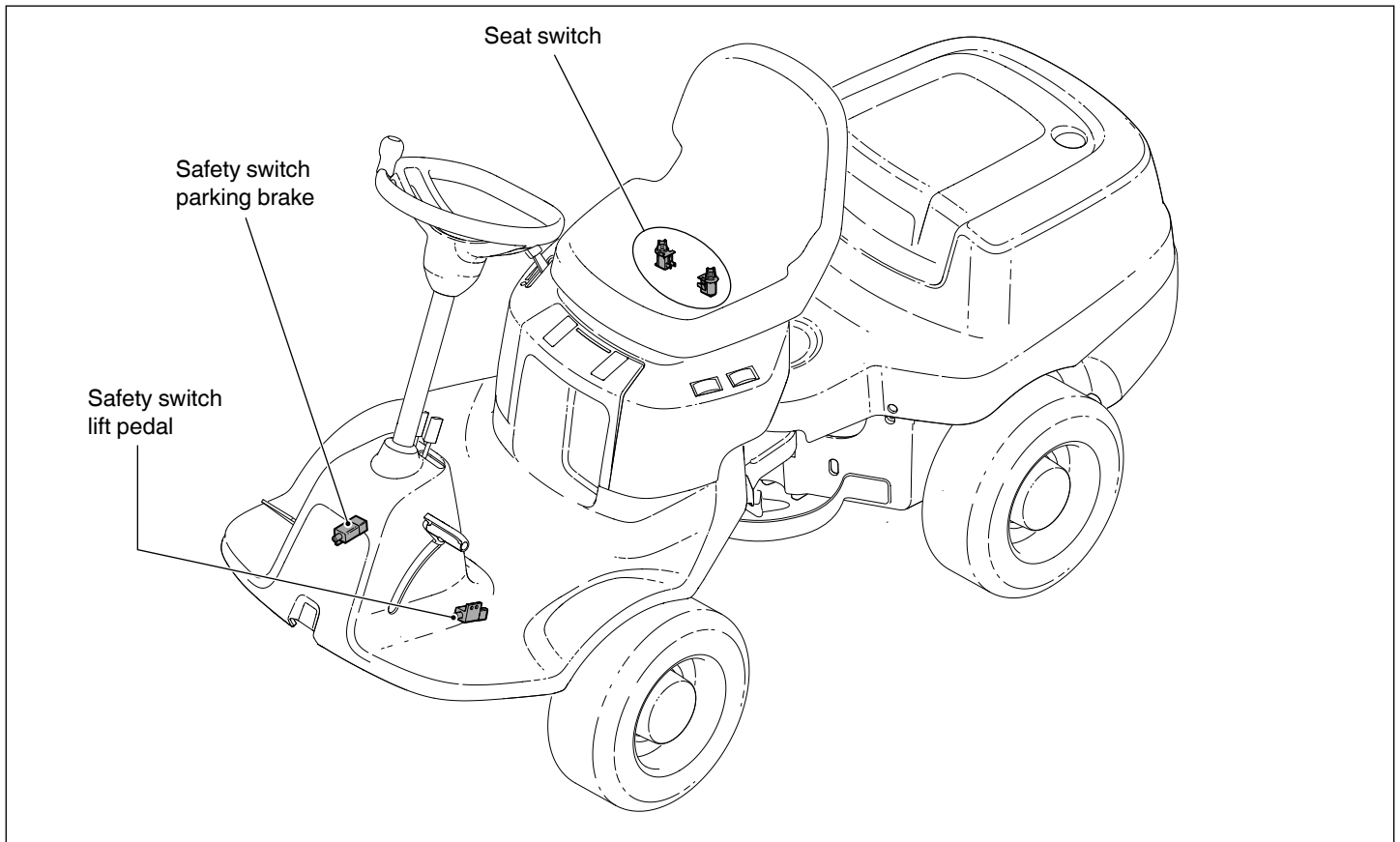

The electrical system consists of several safety circuits.

Therefore certain controls and pedals are fitted with switches. The switches are shown in the figure below.

The signal from the switches is used to open/close the circuit when a prohibited action is to be carried out.

The wiring diagram must be read for full understanding of the electrical system of a special machine model.

All power apart from the starting circuit is protected by the fuse.

### 7.1.1 Cable holders

#### **Warning!**



It is important that all cable holders are securely fastened. If they are not there is a risk of short circuits and fire.

All electrical cables are mounted on the chassis with cable holders. When removing or replacing the electrical cables new cable holders must be installed in the original positions.

#### **Attention!**



Loose electrical cables can cause unnecessary wear to the components This can lead to short circuits, damage to plastic protection, paintwork etc.



## 7.2 Troubleshooting

### Attention!



Do not wear rings, bracelets, necklaces or other similar metal items when working with the machine electrical system. It can lead to short circuits or fires.

This section describes the troubleshooting procedures when an electrical fault has occurred in one of the machine functions.

The section also describes what actions should be taken to rectify the fault. Where the troubleshooting schedule is to be used it is important that the following conditions are met:

- The fuse must be checked and replaced if necessary.
- The battery must be charged.
- All cables shall be OK.
- All connections shall be OK.
- The conditions for carrying out a procedure must be met. For example, if the engine is to be started the operator must be sitting on the seat, the parking brake must be depressed and the power take off in the disengaged position.

Where a troubleshooting schedule is to be followed it is assumed that the cables are correctly connected to their terminals.

In certain cases, after a long period of use or because of mechanical damage, wear to the cables can occur in, for example, the pivot point of the machine.

The pages that follow require no complicated measurements, checks or logical steps to isolate the fault.

The measures are listed with the most likely first.

This means that if the first step does not help, reset and perform the next action.

Continue until the fault is located.



### Battery discharges repeatedly

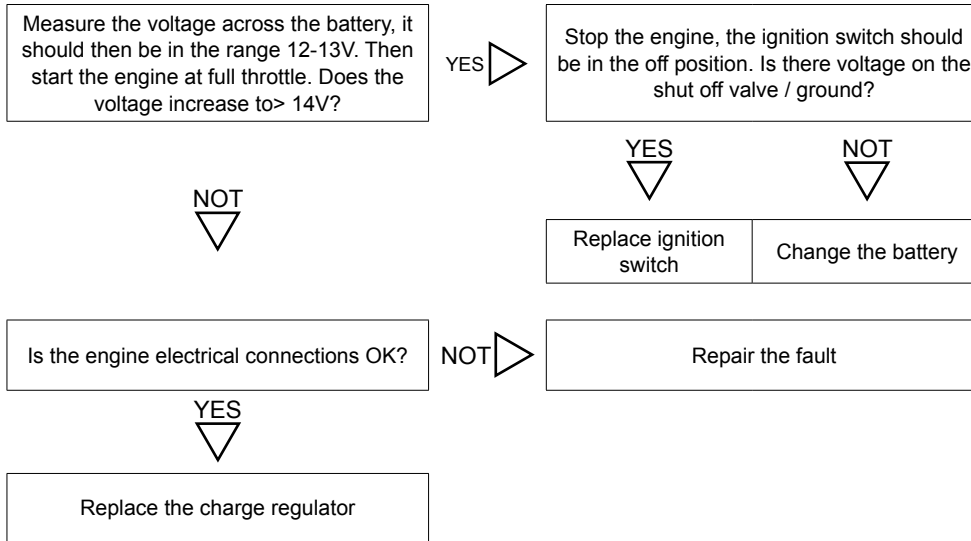

### The engine does not stop

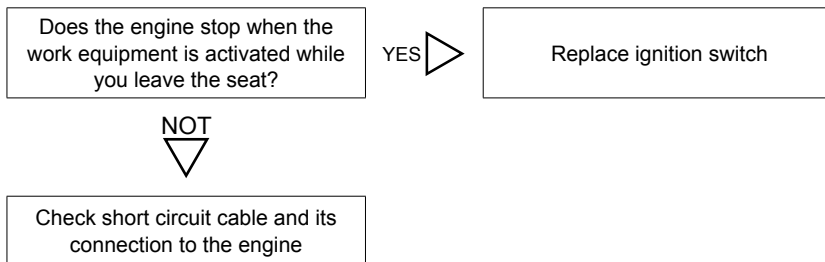

### Electric height adjustment does not work

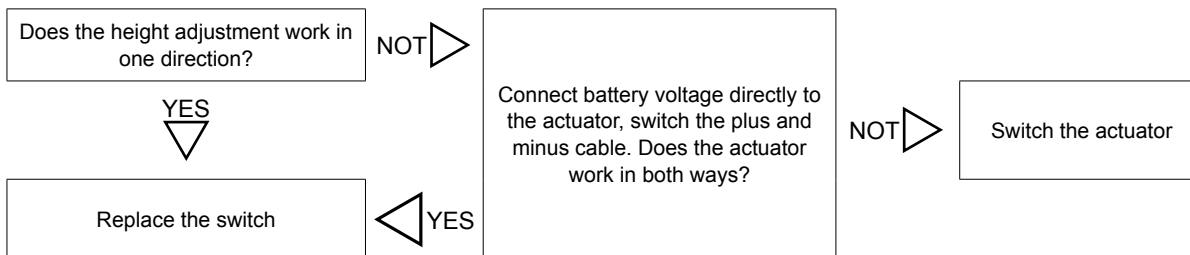

### The engine can be started without the parking brake activated

Change the parking brake switch

### The blades does not stop when the operator leaves the seat

Change the seat switch

### The blades does not stop when lifting the mower deck

Change the lifting switch

### The blades can start without anyone sitting on the seat

Change the seat switch (Black)

### You can not start the blades

Is it possible to start the blades if you short out the connector cables to the lifting switch

YES ▷

Change the lifting switch

NOT  
▽

Is it possible to start the blades if you short out the connector cables to the seat switch (black)?

YES ▷

Change the seat switch

NOT  
▽

Does the safety relay work?

YES ▷

Change the power switch

NOT  
▽

Change the safety relay

### The engine does not stop when the operator leaves the seat

Is it possible to start the engine when the parking brake isn't activated?

YES ▷

Change the parking brake switch

NOT  
▽

Change the seat switch (Grey)

## **7.3 Electric cables**

### **7.3.1 Description**

In this section the workshop manual will display the cables for both machines to increase the understanding of the electrical system and also explain what the various connections are for.

The cables that the workshop manual covers are:

- Cables PARK 300 M
- Cables PARK 300

### 7.3.2 Cables PARK 300 M

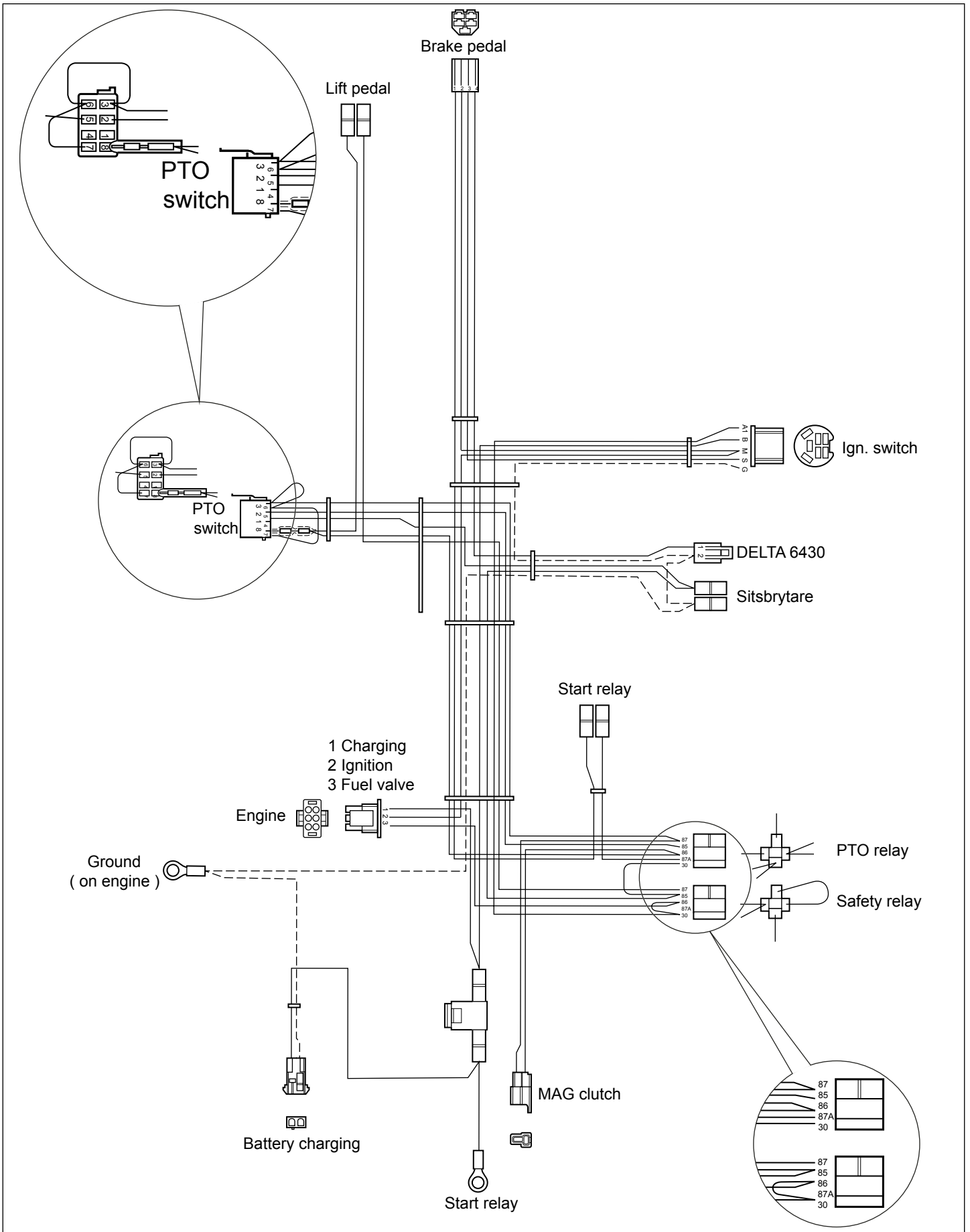

### 7.3.3 Cables PARK 300

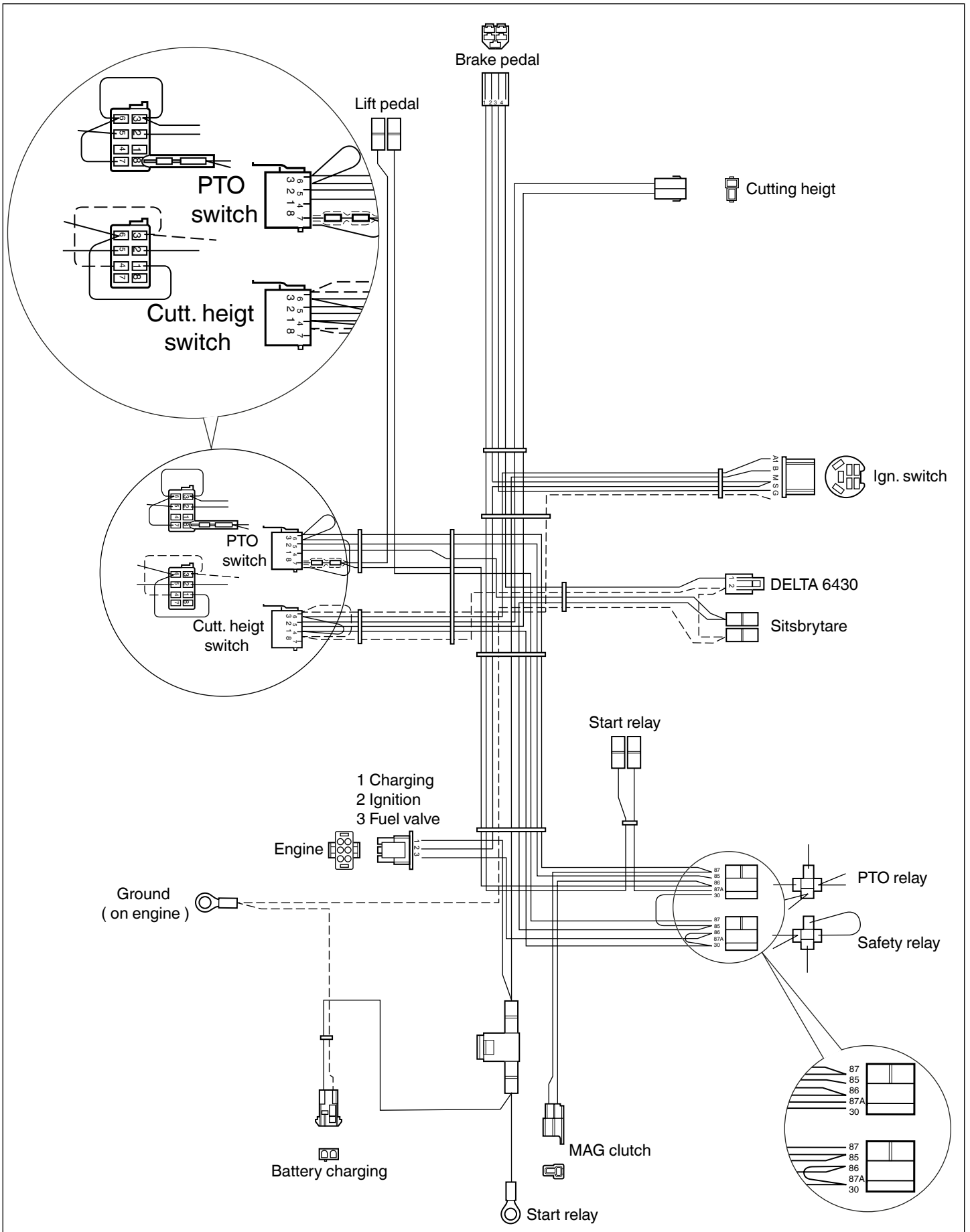

## 7.4 Repair and replacement

### Warning!



Do not wear rings, bracelets, necklaces or other similar metal items when working with the machine electrical system. It can lead to short circuits or fires.

### 7.4.1 Relay positions

The relays are located under the engine cover, in front of engine. To replace or check of one or more relays the engine cover has to be removed.

 [2.1.1](#) for a description of the disassembly.

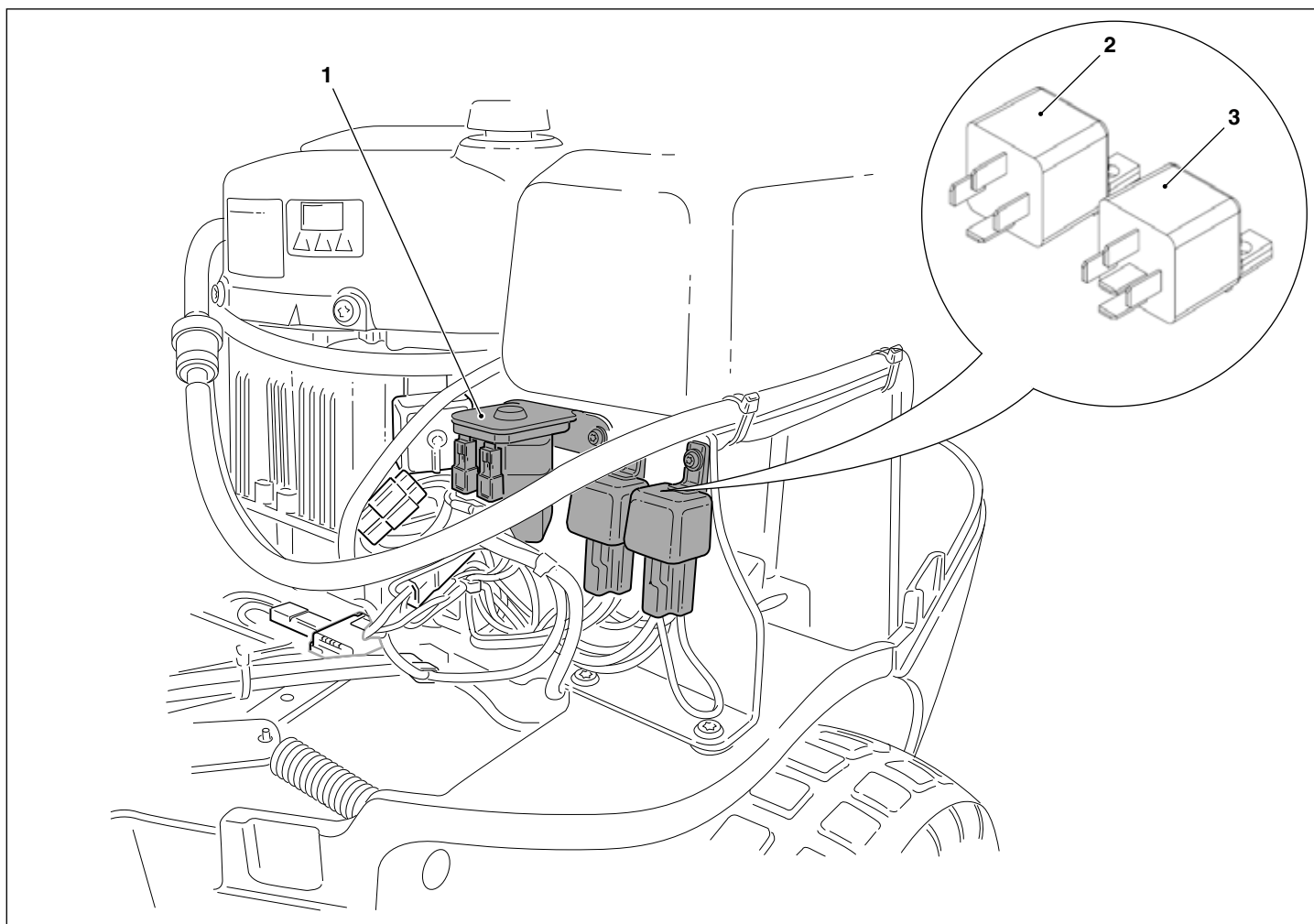



## 7.4.2 Replacing the fuse

### Attention!



The current strengths given in this section are the maximum values of the fuse that may be installed. If a higher current fuse is installed there is a risk of fire damage to the machine.

The machine is equipped with one fuse.

The fuse is located under the machine engine cover, see picture below. To replace or check the fuse the engine cover has to be removed.

 [2.1.1](#) for a description of the disassembly.

Designation	U.M.	PARK 300 M	PARK 300
Main fuse	A	20	

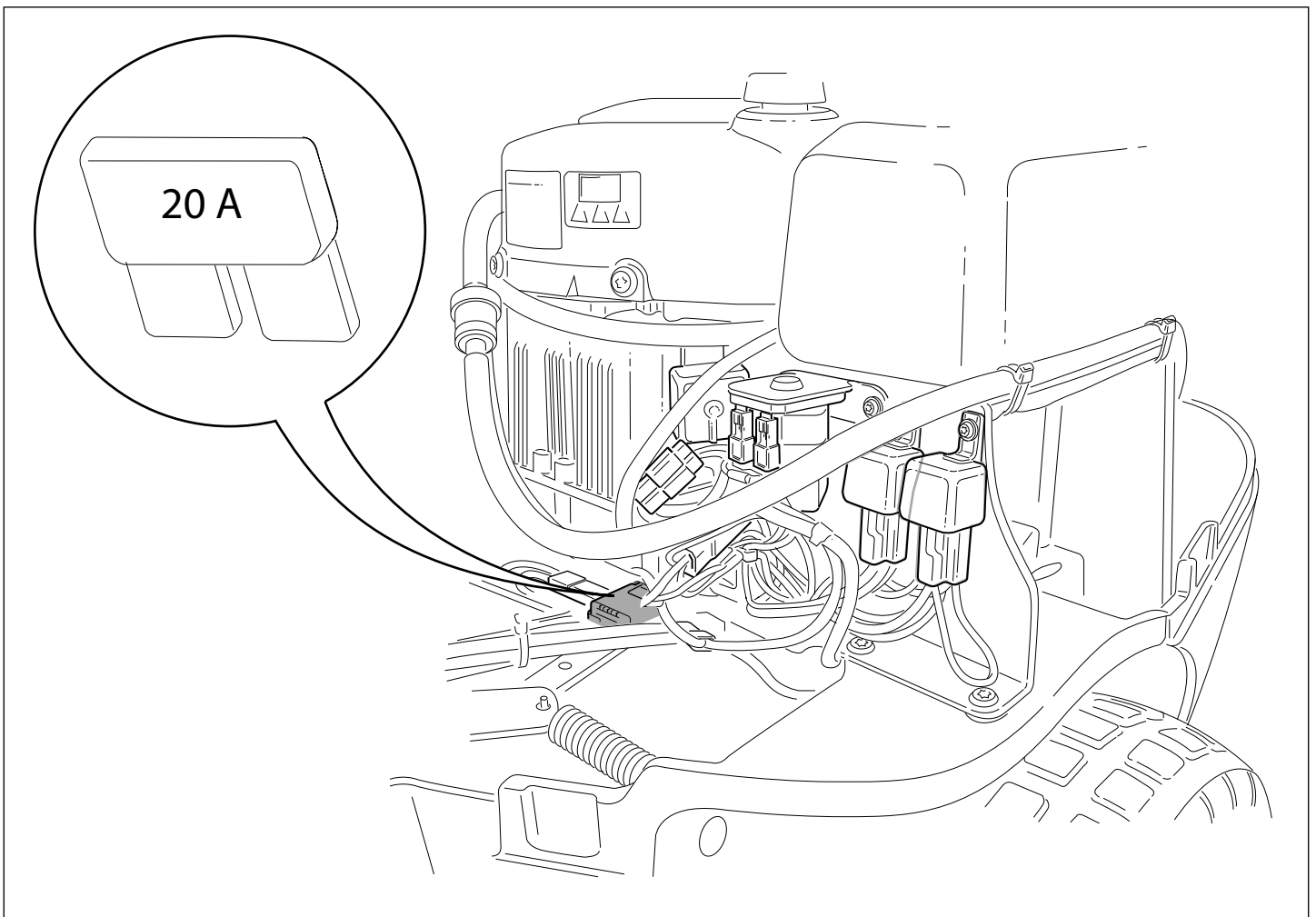

### 7.4.3 Replacing switches

The switches are pressed into place in their respective rectangular holes in the control panel. To change a switch, follow the procedure below:

1. Remove the relevant protection to make the switch accessible.
2. Press in the fixing hook in the connection and pull the connection from the switch. See figure. Certain connections have 2 fixing hooks.
3. Press the fixing tabs, on both sides of the switch, against the switch. Use a screwdriver or similar to slide the switch up. See figure.

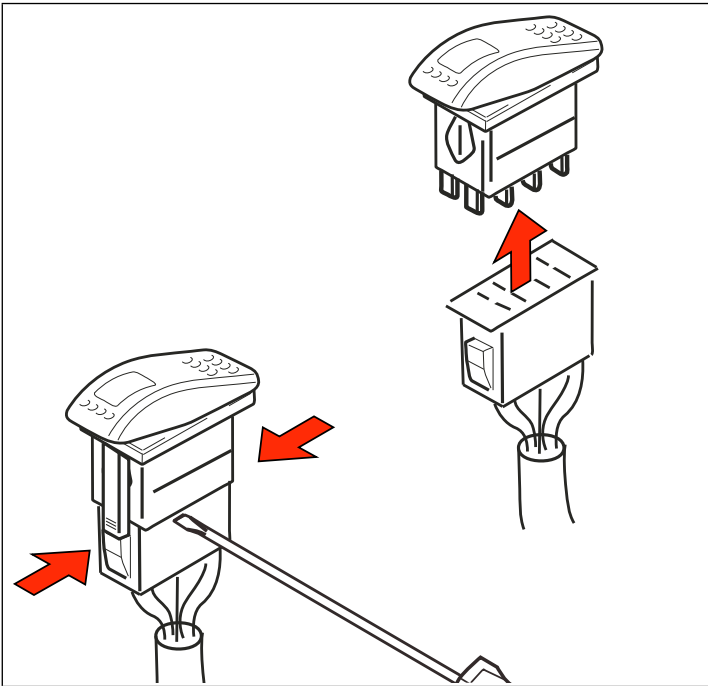

The switches are pressed into place in their respective rectangular holes in the control panel. To change a switch, follow the procedure below:

1. Remove the relevant protection to make the switch accessible.
2. Press in the fixing hook in the connection and pull the connection from the switch. See figure. Certain connections have 2 fixing hooks.
3. Press the fixing tabs, on both sides of the switch, against the switch. Use a screwdriver or similar to slide the switch up. See figure.

### 7.4.4 Replacing switch controls

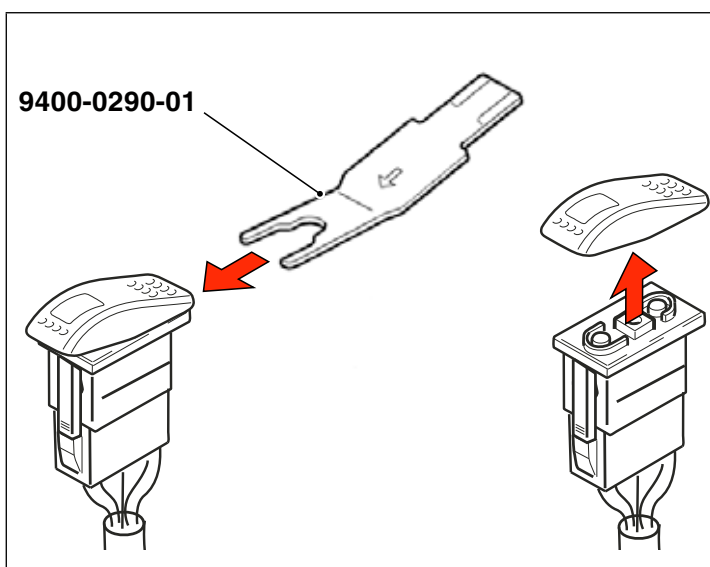

To remove the switch use a special tool. The tool reference number is in the replacement parts list.

Remove the button by pressing in the tool from behind. Press until the button hops up.

The button is easily installed by pushing down into the switch hole.

### 7.4.5 Connections

All connections must be kept clean of dirt, rust and moisture.

Use a small screwdriver to remove a flat pin connector from the plastic holder. Press in the screwdriver behind the connection, hold the cable and pull out the cable with the connection. To reuse reset the catch to its previous position. Crimping pliers can be used to restore a flat pin connector, when it has been exposed to long term wear and tear. Other types of connectors may require special tools for removal.

#### Warning!



No metal from the cable may be visible outside the screw connection. Too long stripped cables can cause short-circuits or fires.

### 7.4.6 Removing the battery

Remove the battery as follows:

#### Attention!



When removing the battery always start by removing the negative cable before the positive cable. During assembly, always start by assemble the negative cable before positive cable.

### PARK 300 M

Remove the engine casing; for further details see  [2.1.1](#)

#### Warning!



Empty the tank of any residual fuel.

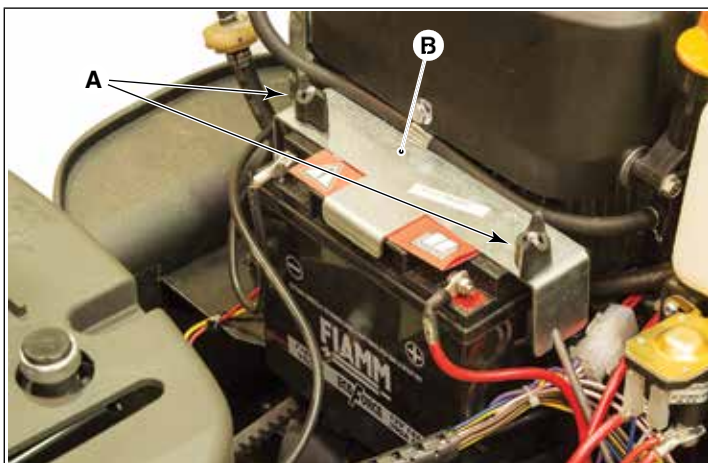

1. Disconnect the (+) and (-) poles of the battery.
2. Unscrew the two wing nuts (A).
3. Remove the stopper (B).
4. Remove the battery.

To reassemble the various parts, repeat the operations in reverse order.

## PARK 300

Remove the engine casing; for further details see  [2.1.1](#)

### Warning!



Empty the tank of any residual fuel.

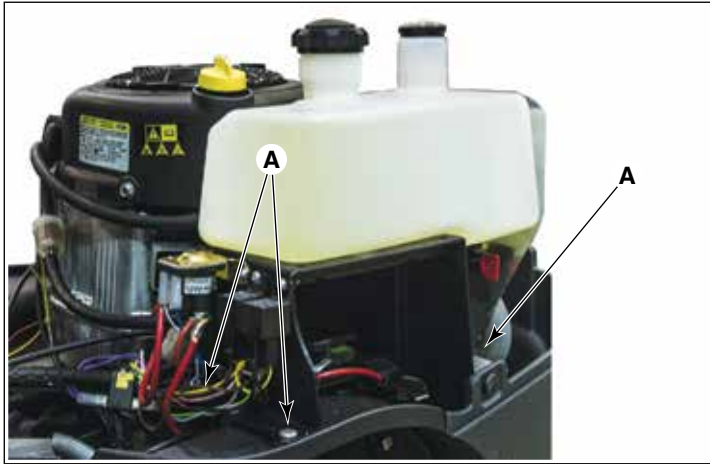

1. Disconnect the (+) and (-) poles of the battery.
2. Remove the tank together with its support, 3 screws (A- Torx T30).
3. Remove the battery.

To reassemble the various parts, repeat the operations in reverse order.

## 7.5 Control panels

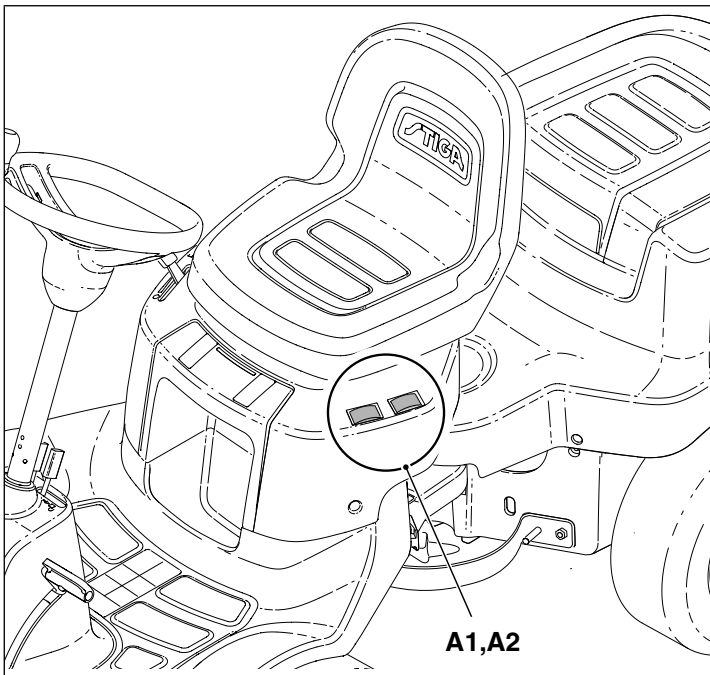

### Switch A1

 The switch can be used to smoothly set the cutting height of the cutting deck with electric cutting height adjustment.

### Switch A2

 Switch for engaging and disengaging the operation of the front mounted implement.

Two positions:

1. Press the front part of the switch  
– PTO engages. The symbol will light up.
2. Press the rear part of the switch  
– PTO disengages.

### 7.6 Wiring diagram

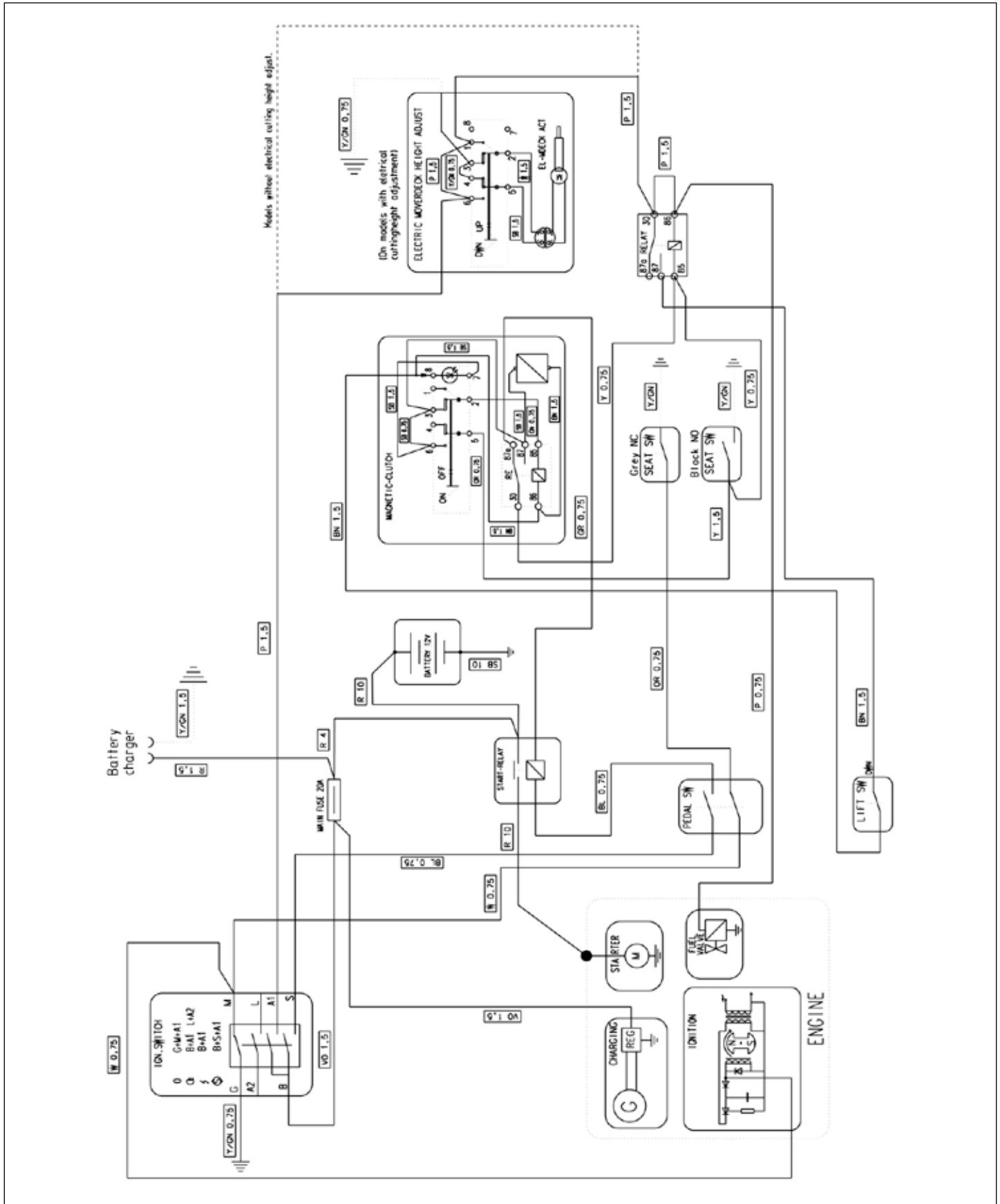

# 8 Mower Decks

## Table of contents

<b>8.1 Original blades</b> .....	<b>67</b>
8.1.7 Why it is so important to use original blades and blade tips from the retail dealer	67
<b>8.2 Replacement of blades</b> .....	<b>68</b>
8.2.1 Disassembly .....	68
8.2.2 Assembly .....	68
<b>8.3 Replacement of belt</b> .....	<b>69</b>
8.3.1 Disassembly .....	69
8.3.2 Checks .....	70
8.3.3 Assembly of belt .....	70
<b>8.4 Replacements of the hub</b> .....	<b>71</b>
8.4.1 Disassembly .....	71
<b>8.5 Synchronising, blades</b> .....	<b>72</b>
<b>8.6 Replacement of the cylinder / engine lifting</b> .....	<b>73</b>
<b>8.7 Replacement of the spring of the lift lever manual</b> .....	<b>73</b>

## General description

The deck are equipped with two synchronised rotating blades. The tracks of adjacent blades are overlapping each other, which means that the synchronization is vital.

All shafts/pulleys are pivoted in sealed and permanent lubricated ball bearings.

All decks are provided with a quick-coupling to simplify the lifting up procedure for cleaning and inspection and. The decks are also provided with an electrical or manual adjusting device for the cutting height.

All decks are tested prior to delivery and are delivered as completely assembled as possible. This ensures that assembly on delivery is rapid and simple.

This chapter describes how to repair and adjust the cutting device assembly.

For information on how to install it on the main machine and for information on periodical maintenance and cleaning operations, please refer to the INSTRUCTION MANUAL.

## Safety

To reduce the risk of accidental injury in the event of a collision and to protect important parts in the cutting deck, a force limiter is integrated as follows.



- Shear bolts between blades and blade bar.
- Torque limiting between gear wheels and blade shaft.
- Possibility of positive drive belt slipping on the plastic gear wheels.

## 8.1 Original blades

### 8.1.7 Why it is so important to use original blades and blade tips from the retail dealer?

The table below shows the demands on original blades and blade tips, delivered from the retail dealer.

The table is intended to display the importance to use the original blades and blade tips.

Esempio	Remarks
<p>No splitting of blade tips.</p> 	<p>Using steel balls, the manufacturer simulates what can happen if you drive over foreign objects on the lawn. The sharpening of the blades may be destroyed, but no parts are allowed to loosen or fly away.</p>
<p>No splitting of blades.</p> 	<p>The impact test is the toughest durability test a lawn mower can be subject to. An iron pipe is placed right into the blades during operation. The blade can be deformed but it may not under any circumstances, come off or split. This test verifies that blades and other parts fulfil the high safety requirements.</p>
<p>Optimal balance. Minimum of noise. Minimum of vibrations.</p> 	<p>Blades and blade tips from the retail dealer have exactly the same weight. Blades and blade tips from the retail dealer are optimal balanced. This guarantee a minimum of vibration and noise which gives a maximal durability of the machine. It also guarantee that the machine corresponds to the specification according to noise and vibrations.</p>
<p>Optimal cutting result.</p>	<p>Blades and blade tips from the retail dealer are optimized in the application. I.e. the blades are adapted to the shape och the cover and the number of revolutions to give the best cutting result.</p>

## 8.2 Replacement of blades

### Warning!



The blades are sharp. Always wear gloves when working with the blades to avoid injury.

### Warning!



When replacing, both blades on the same blade bar must be replaced to avoid imbalance.

### 8.2.1 Disassembly

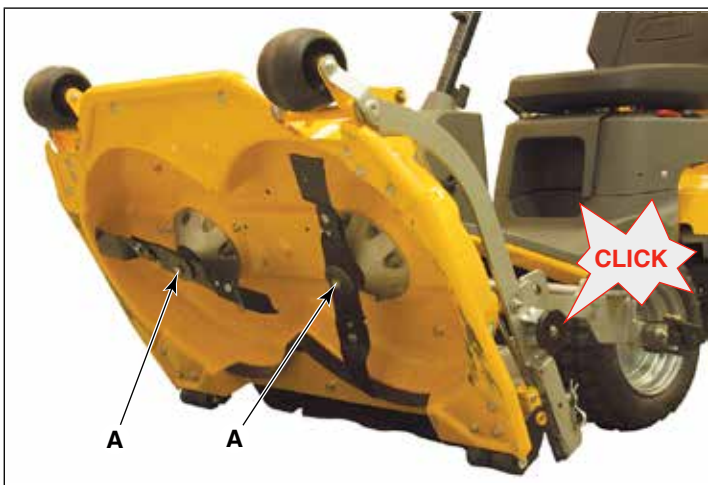

1. Rise the deck to its service position. See *INSTRUCTION MANUAL*.
2. Release the screws (A) (Use a 17 mm spanner) that hold the blades, and remove the blades.
3. After removing the blades, check whether the shafts are damaged. This is best done by rotating the shafts to see if they are out of true.

### 8.2.2 Assembly

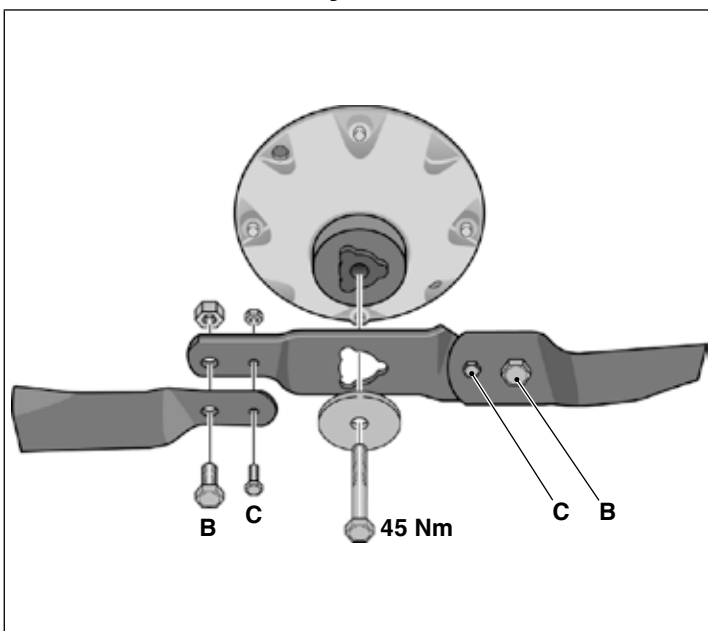

1. Fit the blades according to the figure. The sharpened surfaces of the blades shall face in the rotation direction which is left when the deck is raised.

#### NOTE:

- The blades and blade bar must be installed as in the figure.

#### Tightening torque:

Screws (B) - 45 Nm

Shear bolts (C) - 9.8 Nm

In the event of a collision, the shear bolts (C) can break and the blades bend back. If this has happened, install genuine shear bolts and tighten as above.

2. Tighten all screws.



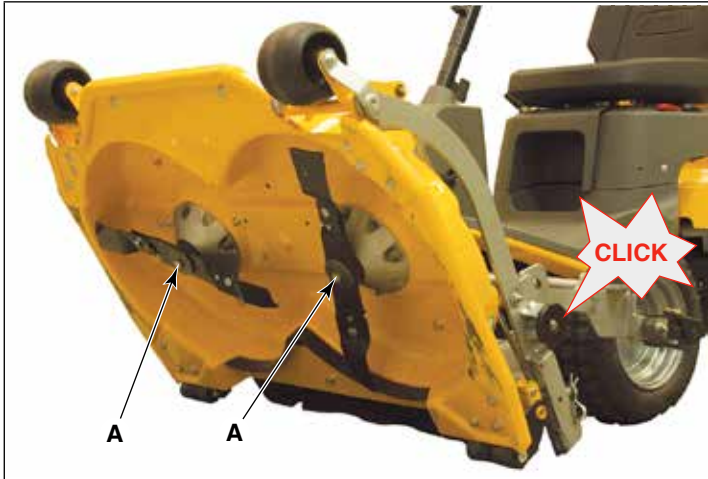

3. Rise the deck to its service position. See *INSTRUCTION MANUAL*.
4. Screw the screws (A) - use a 17 mm spanner) to hold the blades.

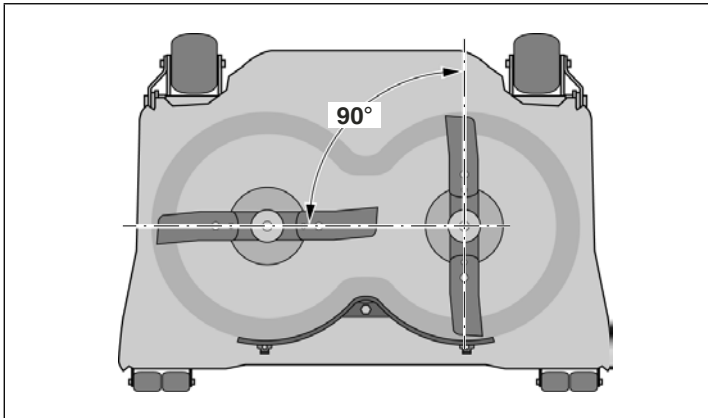

5. Reinstall the blades at 90° to one another.
- NOTE:**
- The blades can be turned 1/3 of a turn in their mountings. Select positions so that the blades are offset 90° from each other. See "Synchronising, blades"  **8.5**.

## 8.3 Replacement of belt

### 8.3.1 Disassembly

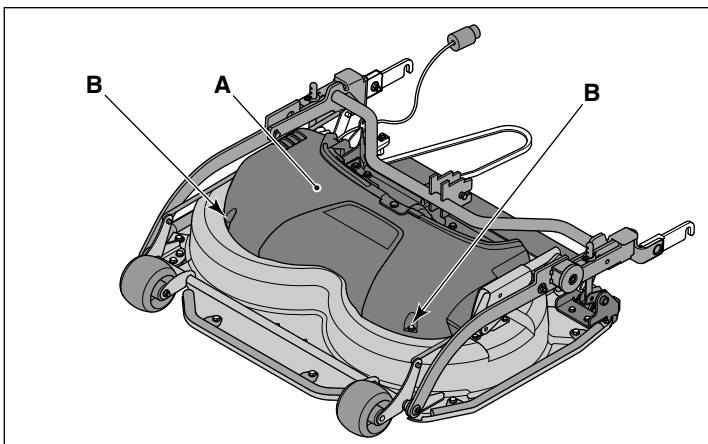

1. Remove the belt cover (A) by unscrewing the screws (B). Use a 12 mm box spanner.

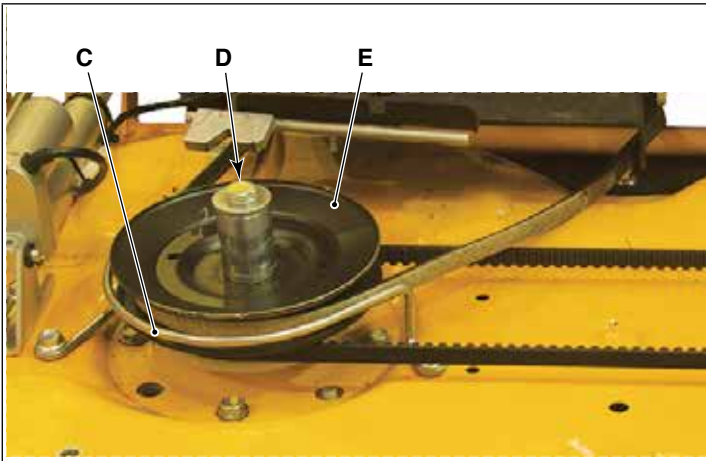

2. Remove the following:
  - Belt guide (C) with screws (13 mm key)
  - Shaft screw (D) with washer and bush (17 mm key)
  - Pull up the pulley (E).

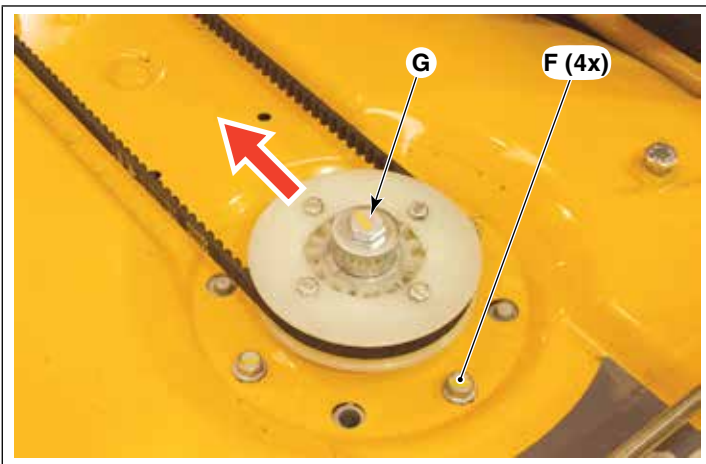

3. Loosen the four screws (F) for the left bearing housing a couple of turns.

**NOTE:** The left bearing housing is lateral adjustable to perform the timing belt adjustment.

4. Remove the screw (G) with washer and the bush at the right shaft and lift the pulley together with the belt.

### 8.3.2 Checks

1. Check the torque limiting between gear wheels and blade shaft. See "Synchronising, blades"  8.5.
2. Check the two blade shaft bearings as follows:
  - Grab the pulley and force it in the radial direction. No radial play shall be felt.
  - Grab the knife and force it in the radial direction. No radial play shall be felt.
  - Rotate the shaft. No abnormal bearing noise shall be heard.

The bearing housings are not divided in additional spare parts. If bearing failure is detected, replace the entire bearing housing.

### 8.3.3 Assembly of belt

Assemble the timing belt in the reverse order.

Correctly synchronised blades must be offset 90° from each other. See "Synchronising, blades"  8.5.

Before the left bearing housing screws are tightened, the belt shall be adjusted.

Adjust as follows:

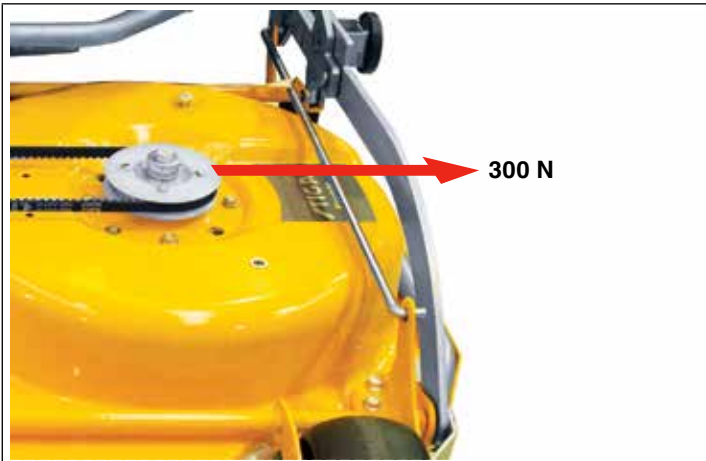
**Alternative A**

1. Stretch the belt by pulling the the left bearing housing with a force of 300 N (30 kg).
2. Tighten the four bearing housing screws.

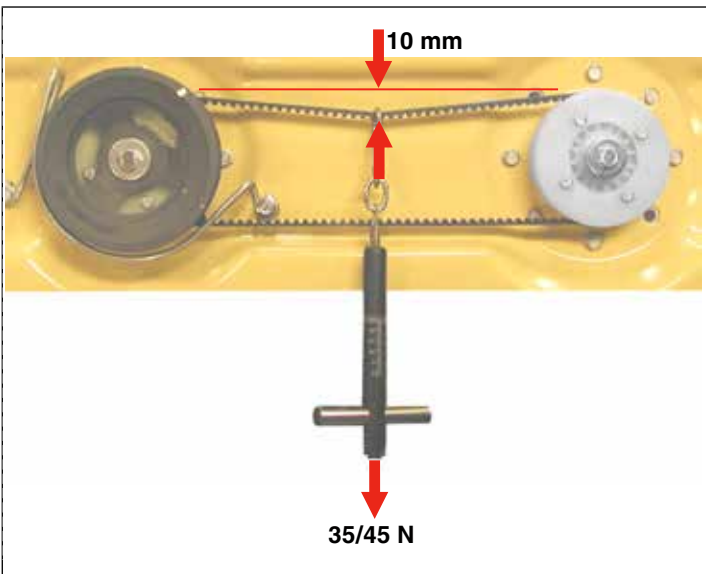
**Alternative B**

1. Stretch the belt by pulling the left bearing housing.
2. Tighten the four bearing housing screws.
3. Apply a force as per the table below in the middle of the belt. The belt shall move 10mm or 12mm in according to the table. If not, loosen the bearing housing and repeat step 1-2 above until the movement is
4. OK.

Timing belt adjustments:

Deck	85 Combi	95 Combi
Force	45 N	35 N
Movement	12 mm	10 mm

## 8.4 Replacements of the hub

Disassembly of blades  [8.2.1](#)

Remove the top guard, the belts and the pulleys.  [8.3.1](#)

### 8.4.1 Disassembly

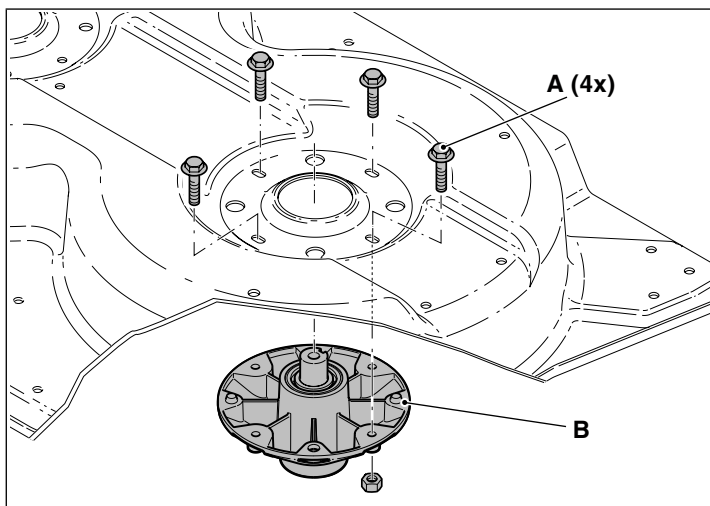

1. Remove the four screws (A), holding the hub (B). Use two 13 mm spanners.
2. Take out the hub.

To reassemble the various parts, repeat the operations in reverse order.

## 8.5 Synchronising, blades

### Attention!



Always check synchronisation after a collision.

The deck has synchronised blades.

If one of the blades has struck a solid object (e.g. a stone), the synchronisation may be altered. This entails a risk of the blades colliding with each other.

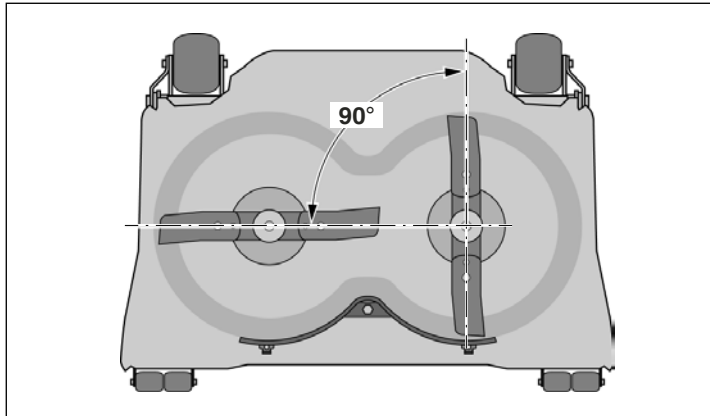

Correctly synchronised blades must be offset 90° from each other. See the figure.

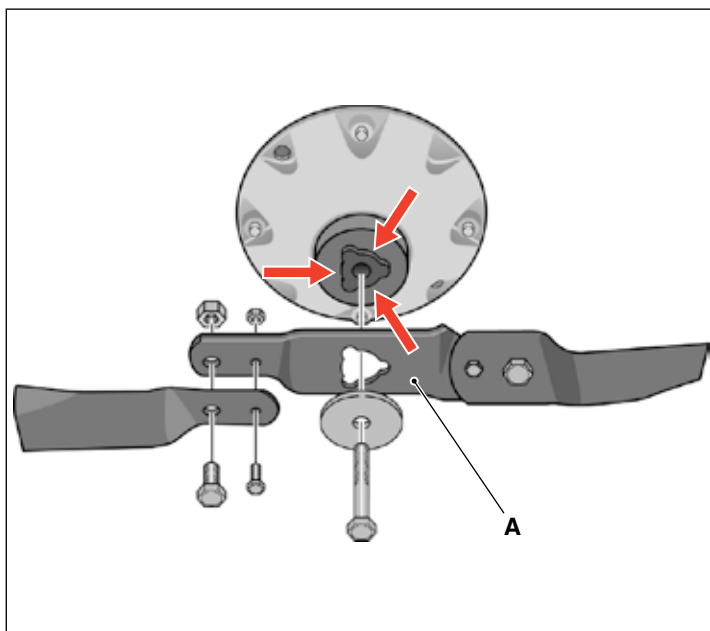

The blades (A) can be turned 1/3 of a turn in their mountings. Select positions so that the blades are offset 90° from each other.

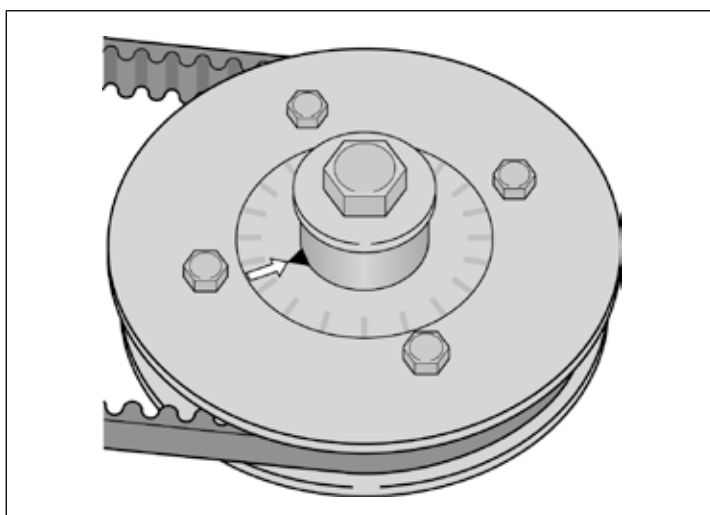

If the blades are not synchronised, one or more of the following faults may have occurred in the cutting deck:

- The positive drive belt has slipped on the gear wheels.
- Torque limiting between gear wheels and blade shaft has deployed. The arrows in the figure must be opposite each other for an intact deck. When torque limiting has deployed, the arrows are not opposite each other.
- The blades member is incorrectly installed on the blade shaft. Can be installed in three different positions.

## 8.6 Replacement of the cylinder / engine lifting

Remove the cutting deck guard.  [8.3.1.](#)

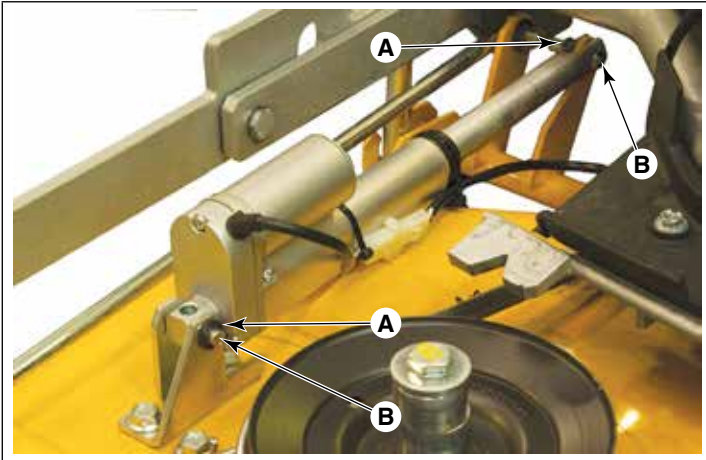

1. Disconnect the plug from the socket on the machine.
2. Remove the shaft-stop washers (A).
3. Extract the pins (B) and remove the drive unit.

To reassemble the various parts, repeat the operations in reverse order.

## 8.7 Replacement of the spring of the lift lever manual

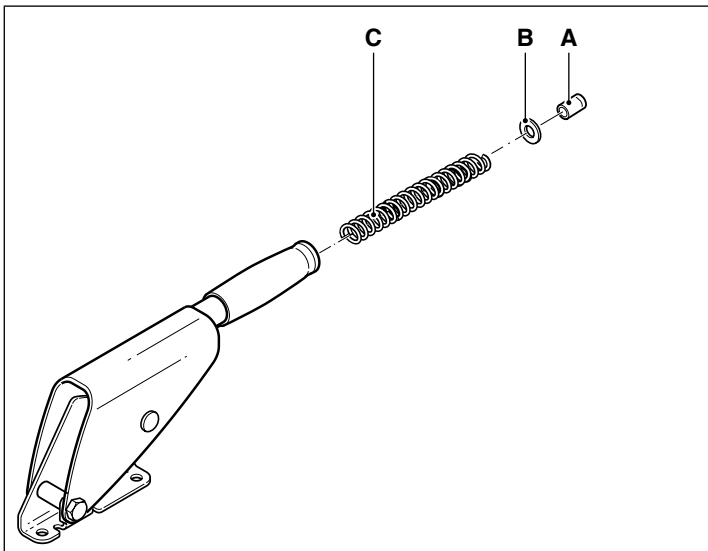

1. Move the lever to the low position.
2. Unscrew the knob (A).
3. Extract the washer (B) and the spring (C).
4. Replace the spring and reassemble all the components in reverse order.

**STIGA**

STIGA S.p.A - Via del Lavoro, 6 - 31033 Castelfranco Veneto (TV) - Italy  
[www.stiga.com](http://www.stiga.com)