

**ECHO**®

**shindaiwa**®

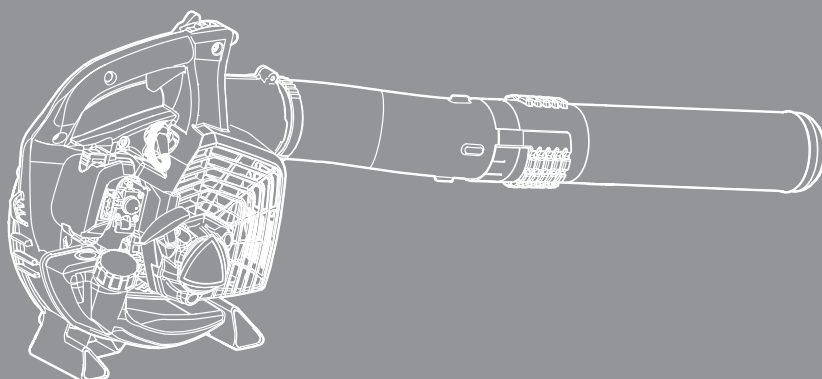

# SERVICE MANUAL

ECHO: PB-2520  
shindaiwa: EB252

(Serial number: 37000001 and after)

## INTRODUCTION

This service manual contains information for service and maintenance of **ECHO HANDHELD BLOWER**, model **PB-2520** and **shindaiwa HANDHELD BLOWER**, model **EB252**.

For systematic diagnosis, to avoid extra work, time loss and to meet Emission regulation, please refer to “Troubleshooting guide” that describes problems, testing, remedies and references. We recommend you make use of Operator’s Manual and Parts Catalogue together with this manual when servicing.

We are constantly working on technical improvement of our products. For this reason, technical data, equipment and design are subject to change without notice. All specifications, illustrations and directions in this manual are based on the latest product information available at the time of publication.

	<b>Page</b>		<b>Page</b>
<b>1 SERVICE INFORMATION</b> .....	2	<b>6 FUEL SYSTEM</b> .....	30
1-1 Specifications .....	2	6-1 Inspecting air filter .....	31
1-2 Technical data .....	3	6-2 Inspecting fuel cap and fuel strainer.....	31
1-3 Torque limits .....	4	6-3 Inspecting fuel tank and line.....	32
1-4 Special repairing materials.....	4	6-4 Inspecting and replacing tank vent.....	33
1-5 Service limits .....	5	6-5 Replacing fuel line, fuel return line, tank vent line and grommet.....	35
1-6 Special tools.....	6	6-6 Adjusting carburetor .....	36
<b>2 STARTER SYSTEM</b> .....	7	6-6-1 General adjusting rules .....	36
2-1 Disassembling starter assembly.....	8	6-6-2 Initial setting Throttle adjust screw, L mixture needle and H mixture needle.....	37
2-2 Replacing starter rope .....	9	6-6-3 Adjusting carburetor .....	37
2-3 Installing rewind spring.....	10	6-6-4 Inserting limiter plugs .....	38
2-4 Assembling starter.....	11	6-7 Testing carburetor.....	39
2-5 Replacing starter pawl.....	12	6-8 Inspecting crankcase pulse passage .....	40
<b>3 BLOWER SYSTEM</b> .....	13	6-9 Inspecting metering lever height .....	40
3-1 Inspecting fan and fan case .....	14	6-10 Inspecting inlet needle valve .....	41
3-2 Disassembling and assembling fan and fan case.....	14	6-11 Inspecting diaphragm.....	41
<b>4 IGNITION SYSTEM</b> .....	17	6-12 Installing carburetor.....	42
4-1 Troubleshooting guide.....	18	<b>7 ENGINE</b> .....	43
4-2 Testing spark .....	19	7-1 Testing cylinder compression .....	44
4-3 Inspecting spark plug .....	19	7-2 Cleaning cooling air passages .....	44
4-4 Replacing spark plug cap and coil.....	20	7-3 Inspecting muffler and exhaust port .....	45
4-5 Inspecting ignition module.....	21	7-4 Testing crankcase and cylinder sealings .....	46
4-6 Replacing ignition module .....	22	7-5 Replacing oil seal .....	47
4-7 Setting pole shoe air gaps.....	24	7-6 Inspecting cylinder.....	47
4-8 Inspecting ignition switch.....	24	7-7 Inspecting piston and piston ring.....	48
4-9 Replacing ignition switch .....	25	7-8 Disassembling crankcase.....	48
4-10 Inspecting flywheel magnetic force .....	26	7-9 Replacing ball bearings.....	49
4-11 Replacing flywheel and key.....	26	7-10 Assembling crankshaft and crankcase.....	50
<b>5 HANDLE AND CONTROL SYSTEM</b> .....	28	7-11 Installing piston.....	50
5-1 Disassembling and assembling handle and control parts.....	29	7-12 Installing piston ring and cylinder .....	51
		7-13 Assembling engine assembly and other parts .....	52
		<b>8 MAINTENANCE GUIDE</b> .....	53
		8-1 Disassembly chart .....	53
		8-2 Troubleshooting guide .....	54
		8-3 Service intervals .....	56

## 1 SERVICE INFORMATION

## 1-1 Specifications

Dimensions*	Length	mm (in)	324 (12.8)
	Width	mm (in)	233 (9.2)
	Height	mm (in)	355 (14.0)
Dry weight**		kg (lb)	3.9 (8.6)
Engine	Type	YAMABIKO, air-cooled, two-stroke, single cylinder	
	Rotation	Counterclockwise as viewed from the output end	
	Displacement	cm <sup>3</sup> (in <sup>3</sup> )	25.4 (1.550)
	Bore	mm (in)	34 (1.339)
	Stroke	mm (in)	28 (1.102)
	Compression ratio	7.0	
Carburetor	Type	Diaphragm, horizontal-draft with purge bulb	
	Model	ZAMA RE110147B	
	Venturi size-Throttle bore	mm (in)	9 - 9 (0.354-0.354)
Ignition	Type	CDI (Capacitor discharge ignition) system, Digital magneto	
	Spark plug	NGK BPMR8Y	
Starter	Type	Automatic rewind	
	Rope diameter x length	mm (in)	3.0 x 900 (0.12 x 35.4)
Fuel* <sup>1</sup>	Type* <sup>2</sup>	Mixed two-stroke fuel	
	Mixture ratio	50 : 1 (2 %)	
	Gasoline	Minimum 89 octane petrol	
	Two-stroke air cooled engine oil	ISO-L-EGD (ISO/CD13738), JASO FC/FD	
	Tank capacity	L (U.S.fl.oz.)	Full tank capacity: 0.55 (18.6) Usable tank capacity: 0.50 (16.9)
Exhaust	Muffler type	Spark arrester muffler with catalyst	
Throttle	Type	Throttle Trigger and Throttle Setting Device	
Blower	Fan type	Centrifugal type	
	Max. air volume (with pipes)	m <sup>3</sup> /min (cfm)	12.8 (453)
	Max. air velocity (with pipes)	m/s (mph)	76.2 (170)
	Discharge ID	mm (in)	65.5 (2.6)

\*Without blower pipes    \*\*With blower pipes

ID: Inner diameter

\*<sup>1</sup> Refer to Operator's manual    \*<sup>2</sup> Premixed alkylate fuel for 2-stroke can be used



**1-2 Technical data**

Engine			
Compression pressure	MPa (kgf/cm <sup>2</sup> ) (psi)		0.77 (7.8) (111)
Ignition system			
Spark plug gap	mm(in)		0.6 - 0.7 (0.024 - 0.028)
Spark test	Tester gap w/ spark plug	mm(in)	4.0 (0.16)
	Tester gap w/o spark plug	mm(in)	6.0 (0.24)
Secondary coil resistance	Ω		960 - 1,000
Pole shoe air gaps	mm(in)		0.3 - 0.4 (0.012 - 0.016)
Ignition timing	at 3,000 RPM	°BTDC	30
	at 7,500 RPM	°BTDC	30
Carburetor			
Test Pressure, minimum	MPa (kgf/cm <sup>2</sup> ) (psi)		0.05 (0.5) (7.0)
Metering lever height	mm(in)	0.1 - 0.25 (0.004 - 0.01)	lower than diaphragm seat
Limiter plug / cap			Limiter plug P005-001270
Tool to adjust mixture needles			Screwdriver 2.5 mm
Carburetor adjustment			
1) Initial setting			
H mixture needle	turn out		1 3/4
L mixture needle	turn out		2 1/2
Throttle adjust screw	turn out* <sup>1</sup>		13
Engine warm-up	Idle - WOT : Total	sec.	10 - 180: 190
2) Find idle maximum speed			Adjust L mixture needle to maximum idle speed
3) Set idle maximum speed w/ TAS		RPM	3500
4) Set idle speed by turning L mixture needle CCW		RPM	3000
5) Find WOT maximum speed			Adjust H mixture needle to maximum WOT speed
6) WOT setting		RPM	Turn H mixture needle CCW to decrease WOT speed by : 10 - 30
7) Verify final engine speed with standard equipment			Idle: 2800 - 3200 WOT: 7,150<
		RPM	

BTDC: Before top dead center. WOT: Wide open throttle  
CCW: Counterclockwise TAS: Throttle adjust screw

\*<sup>1</sup> Turn TAS clockwise until its head touches boss. Then turn TAS counterclockwise.

## 1-3 Torque limits

Descriptions		Size	kgf•cm	N•m	in•lbf
Starter system	Starter pulley	M8	70 - 110	7 - 11	60 - 95
	Starter case	M5	50 - 70	5 - 7	45 - 60
Ignition system	Magneto rotor (Flywheel)	M8	160 - 200	16 - 20	140 - 175
	Ignition coil	M5	40 - 60	4 - 6	32 - 50
	Spark plug	M14	130 - 170	13 - 17	113 - 150
Fuel system	Carburetor	M5	30 - 45	3 - 4.5	25 - 40
	Intake insulator	M5	50 - 70	5 - 7	45 - 60
Engine	Crankcase	M5**	70 - 110	7 - 11	60 - 95
	Cylinder	M5**	70 - 110	7 - 11	60 - 95
	Engine mount	M5	60 - 80	6 - 8	50 - 70
	Engine cover	M5 <sup>†</sup>	35 - 60	3.5 - 6	30 - 50
	Muffler	M5	70 - 110	7 - 11	60 - 95
Others	Outer fancase	M5 <sup>†</sup>	35 - 60	3.5 - 6	30 - 50
	Fan	M6	80 - 100	8 - 10	70 - 87
Regular bolt, nut and screw		M3	6 - 10	0.6 - 1	5 - 9
		M4	15 - 25	1.5 - 2.5	13 - 22
		M5	25 - 45	2.5 - 4.5	22 - 40
		M6	45 - 75	4.5 - 7.5	40 - 65
		M8	110 - 150	11 - 15	95 - 130

\*\* The torque differences among four bolts should not exceed 20 kgf•cm (2N•m, 17in•lbf) on one cylinder or crankcase.

<sup>†</sup> Tapping screw

## 1-4 Special repairing materials

Material	Location	Remarks
Grease	Oil seal inner lips	Lithium based grease
	Rewind spring	
	Starter center post	
Thread locking sealant	Ignition switch	Loctite #242, ThreeBond #1344 or equivalent

1-5 Service limits

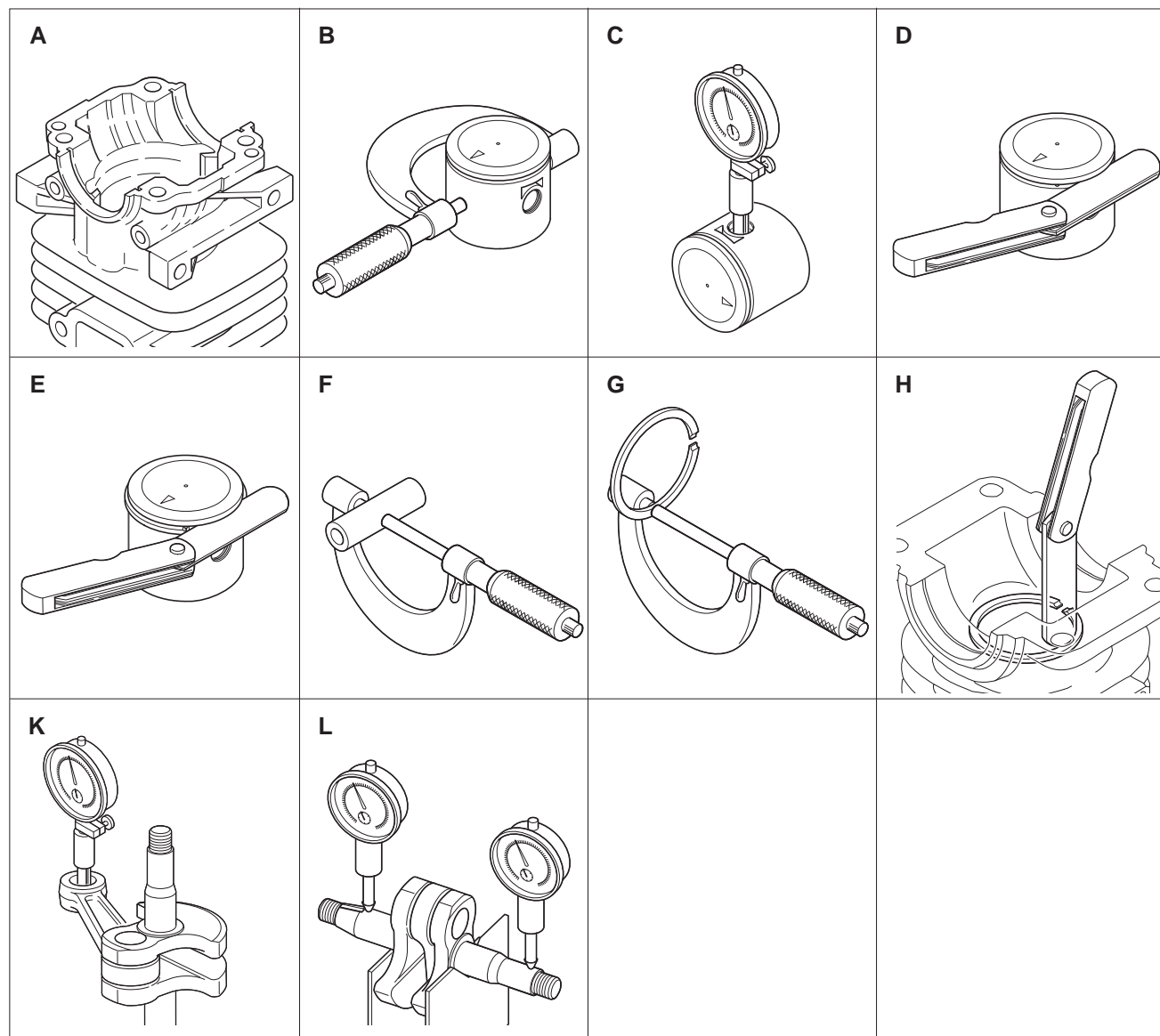

Description		mm (in)	
A	Cylinder bore	When plating is worn and aluminum can be seen	
B	Piston outer diameter	Min.	33.91 (1.335)
C	Piston pin bore	Max.	9.035 (0.3557)
D	Piston ring groove	Max.	1.6 (0.063)
E	Piston ring side clearance	Max.	0.1 (0.004)
F	Piston pin outer diameter	Min.	8.98 (0.3535)
G	Piston ring width	Min.	1.45 (0.057)
H	Piston ring end gap	Max.	0.5 (0.02)
K	Con-rod small end bore	Max.	9.038 (0.3558)
L	Crankshaft runout	Max.	0.02 (0.001)

### 1-6 Special tools

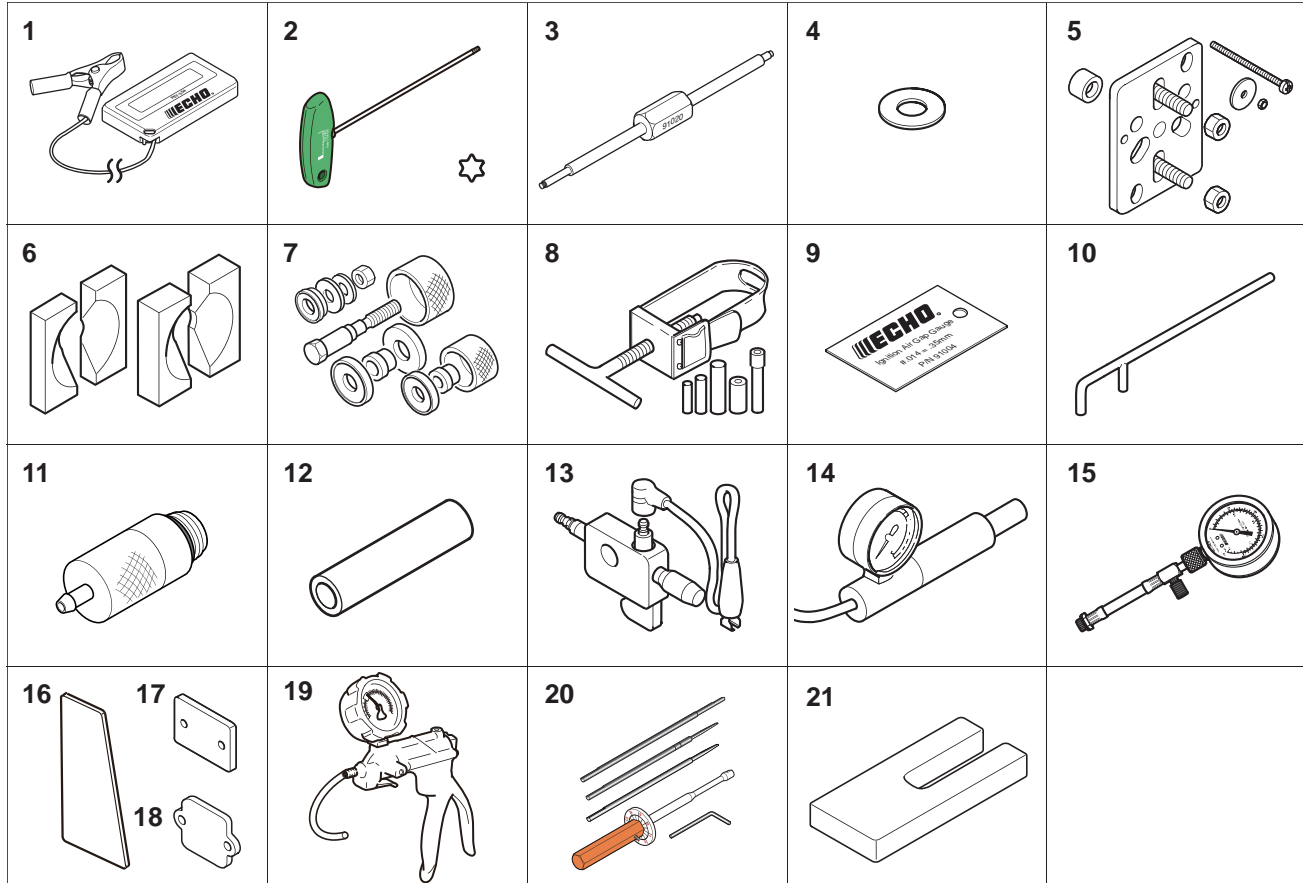

Key	Part Number	Description	Reference
1	PET304	Tachometer PET-304	Measuring engine speed to adjust carburetor
2	X602-000340	Torx wrench (T27)	Removing and installing bolt
3	91020	Limiter plug tool	Removing and installing limiter plug
4	10001-418430	Washer	Installing crankcase oil seals
5	Y089-000111	Puller	Removing magneto rotor
6	897701-02830	Bearing wedge	Removing ball bearings on cankshaft
7	897701-14732	Bearing tool	Removing and installing ball bearings on crankcase
8	897702-30131	Piston pin tool	Removing and installing piston pin (Use 8mm dia. adapter)
9	91004	Module air gap gauge	Adjusting pole shoe air gaps
10	897712-04630	2-pin wrench	Removing and installing pawl carrier
11	A131-000150	Pressure connector	Testing crankcase and cylinder leakage
12	897726-21430	Oil seal tool	Installing crankcase oil seals
13	897800-79931	Spark tester	Checking ignition system
14	897803-30133	Pressure tester	Testing carburetor and crankcase leakages
15	91037	Compression gauge	Measuring cylinder compression
16	91041	Pressure rubber plug	Plugging exhaust port to test crankcase / cylinder leakages
17	897826-16131	Pressure rubber plug	Plugging intake port to test crankcase / cylinder leakages
18	897827-16131	Pressure plate	Plugging intake port to test crankcase / cylinder leakages
19	91149	Pressure / vacuum tester	Testing crankcase / cylinder leakages
20	Y089-000094	Carburetor adjustment tool	Adjusting carburetor
21	897719-02830	Piston holder	Making piston steady to remove and install piston/ring

2 STARTER SYSTEM

- (A) E-ring
- (B) Pawl carrier
- (C) Spring
- (D) Starter pawl
- (E) Screw with washer
- (F) Starter rope
- (G) Rope reel
- (H) Rewind spring
- (J) Starter grip
- (K) Rope guide
- (L) Starter case

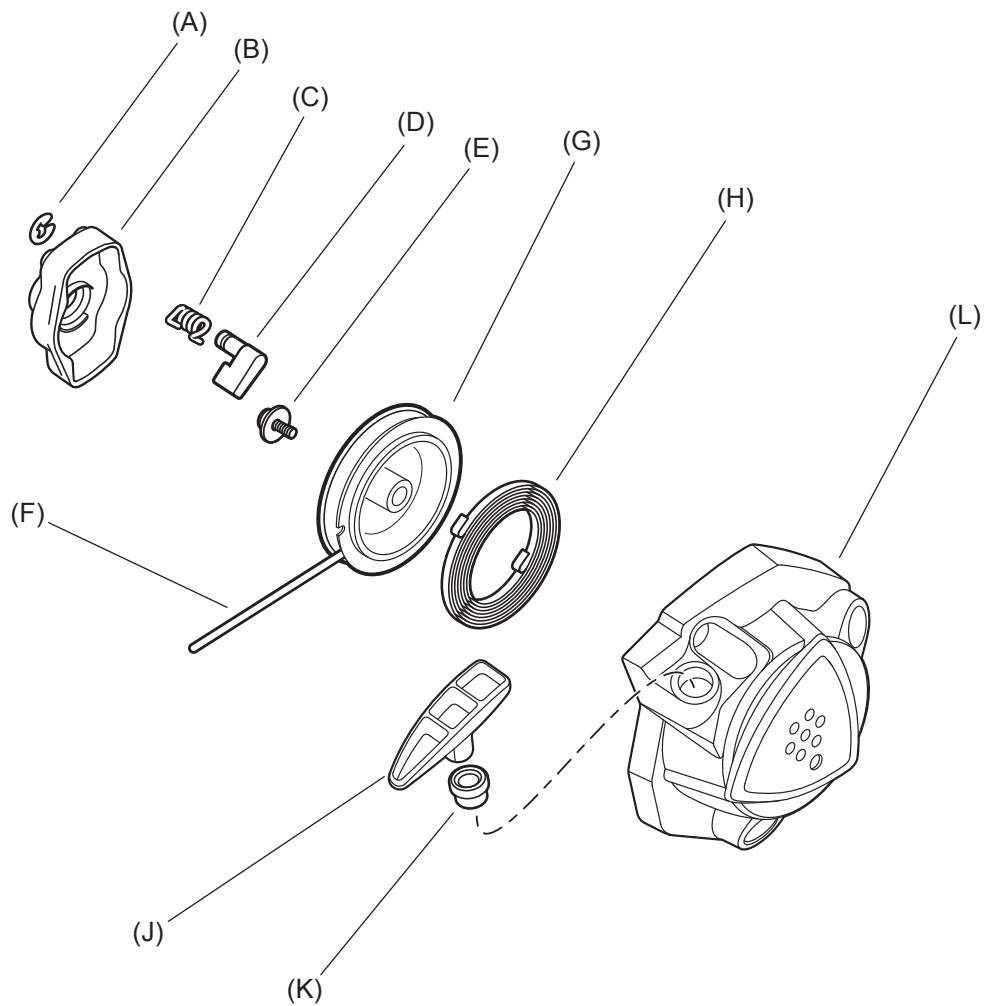

## 2-1 Disassembling starter assembly

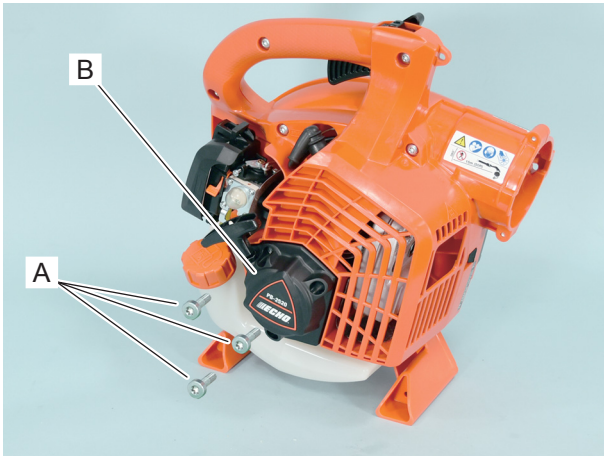

1. Remove three bolts (A) and remove starter assembly (B) from unit.



2. Pull out starter rope about 30cm (12in) and hold rope reel (C) by hand. Loop excess rope in rope reel notch (c) as shown.

3. Rotate rope reel (C) clockwise to release tension of rewind spring.

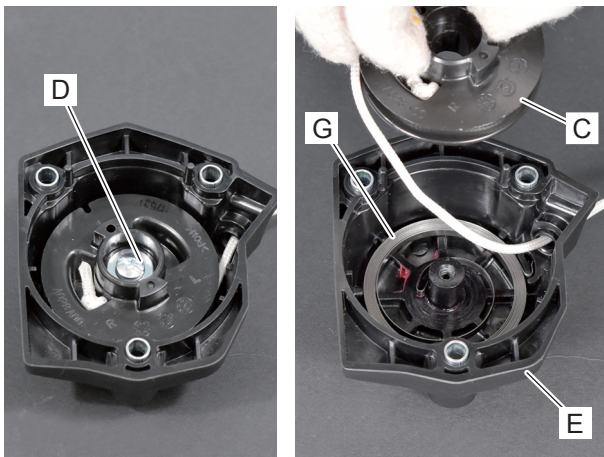

4. Remove screw (D) with washer.

5. Remove rope reel (C) from starter case (E) slowly to prevent rewind spring (G) from unwinding.

**WARNING**  **DANGER**

Wear eye protection and take care when removing starter drum. Rewind spring may unwind suddenly and cause personal injury.



2-2 Replacing starter rope



1. Pull out knot (A) from starter grip and untie knot (A).
2. Pull knot (B) to remove rope from rope reel (C).

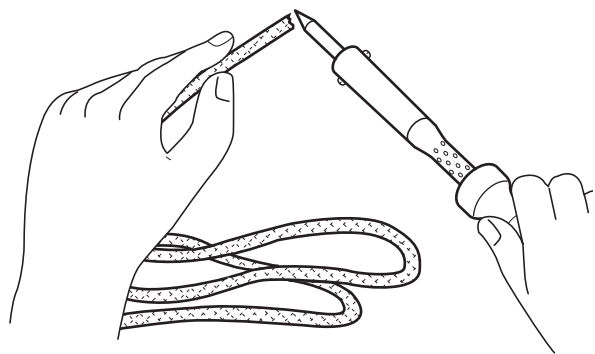

3. When installing a new starter rope, singe both ends of the rope to prevent fraying.

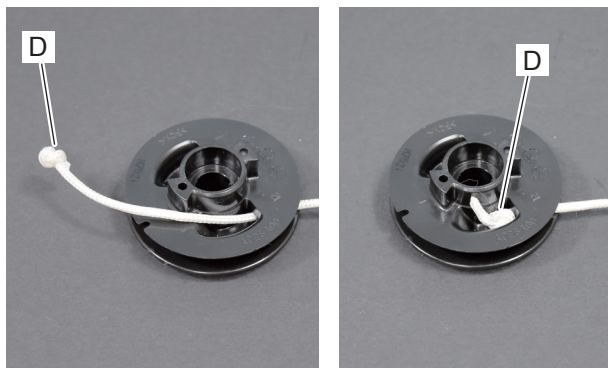

4. Make a knot (D) at end of starter rope and pass the rope through hole of rope reel, then press the knot (D) into recess as shown.

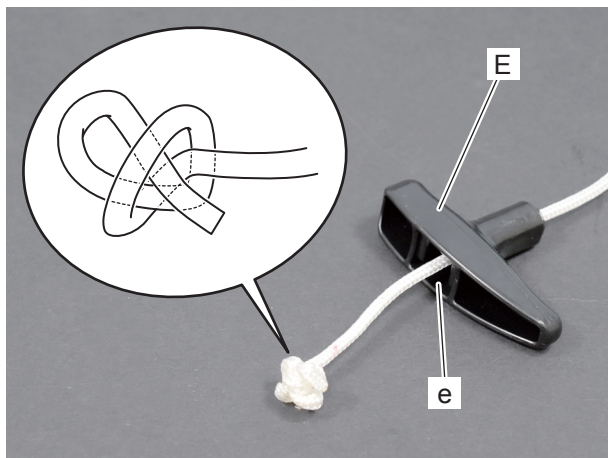

5. Pass the other end of starter rope through starter case, from inside to outside.
6. Pass starter rope through starter grip (E). Make a knot as shown.
7. Tighten knot. Push knot into recess (e) of starter grip.

## 2-3 Installing rewind spring

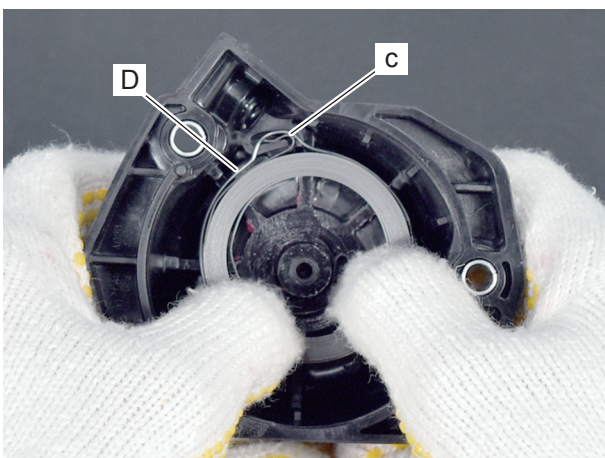
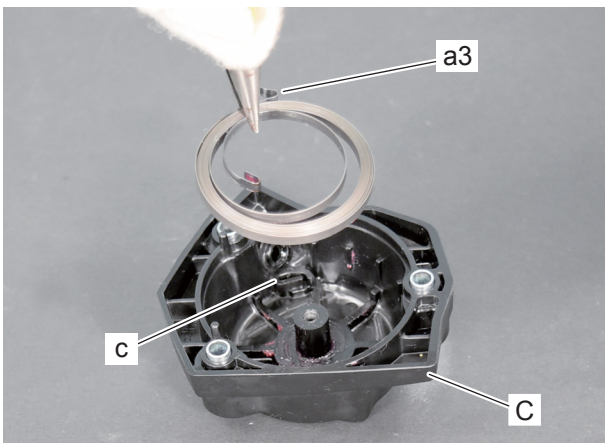
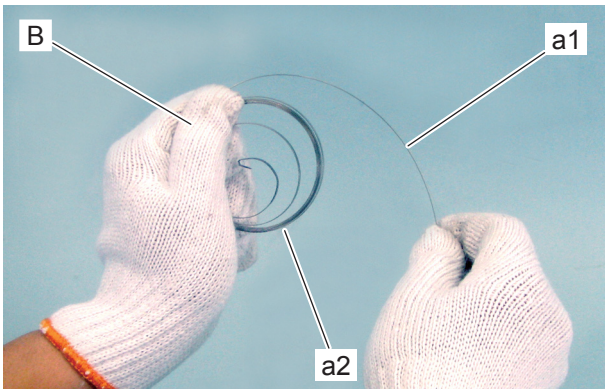
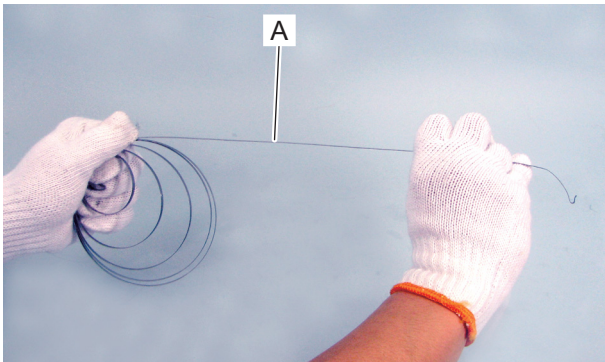
**WARNING**  **DANGER**

Use of eye protection and safety gloves are strongly recommended while working on rewind spring.

If rewind spring unwinds unexpectedly, follow steps 1) to 4).

1) Wind rewind spring (A) by hand. Then draw out the end of spring (A) as shown.

2) Wind drawn-out part (a1) to wound part (a2), keeping wound part tight by hand (B) as shown. Repeating this procedure several times, wind rewind spring smaller than the inner diameter of starter case.

3) Retain rewind spring with a pliers as shown. Set rewind spring in starter case (C), hooking the outer hook (a3) to the holder (c) of starter case (C).

4) Apply small amount lithium based grease to outside of rewind spring.

**NOTE:** Rewind spring supplied as spare part is shipped in temporary retainer (D). Retainer should be removed when installing.

To install new spring wound in retainer:

1) Align outer hook of spring in retainer (D) with holder (c) of starter case.

2) Push spring down into the bottom of case, keeping spring strongly pressed against case.

3) Spring should fall into starter case, and retainer is detached.



2-4 Assembling starter

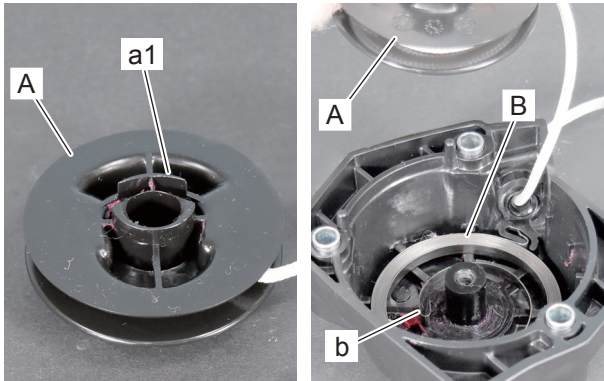

1. Assemble rope reel (A) engaging hook (a1) with hook (b) of rewind spring (B).



2. Check for proper engagement of rewind spring and rope reel (A) by turning rope reel (A) clockwise and counterclockwise.

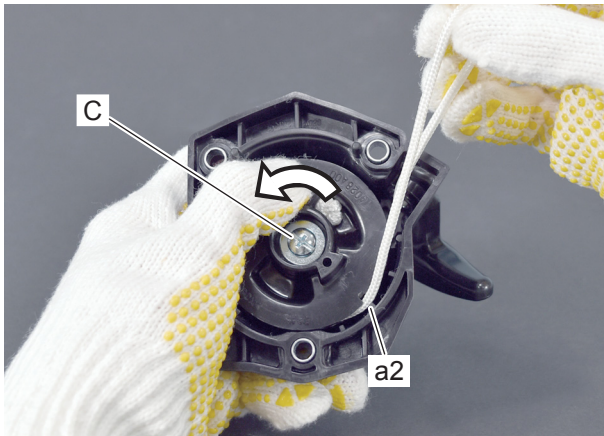

3. Reinstall screw (C) with the washer on starter post.

4. Pull out starter rope inside of starter case. Rotate rope reel counterclockwise several turns with starter rope hooked at notch (a2) as shown. Hold rope reel to prevent it from unwinding and pull out starter grip to take the rope slack.



5. Pull starter several times to check rewind spring tension. If starter is not rewinding fully, increase spring tension by rotating rope reel one more turn counterclockwise following above step 4.

6. Pull out starter rope all the way, and check that rope reel can be rotated an additional half or more turn counterclockwise as shown, to prevent rewind spring from breaking.

7. If rope reel can not be turned counterclockwise, reduce tension by rotating rope reel clockwise one turn with starter rope hooked at notch (a2).

## 2-5 Replacing starter pawl

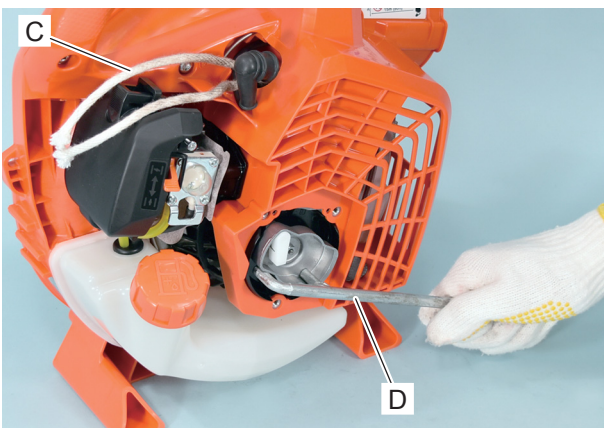
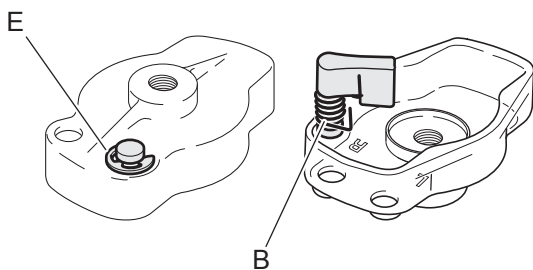
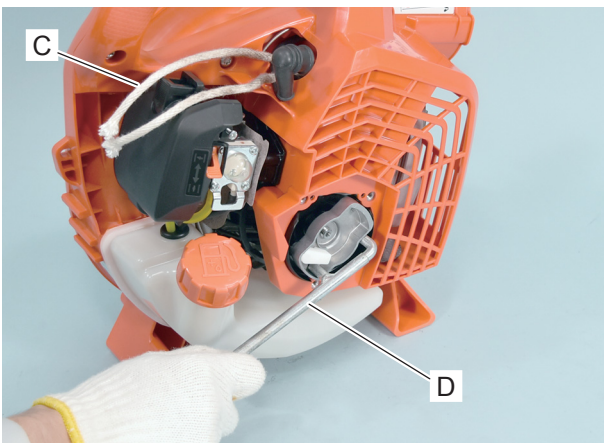
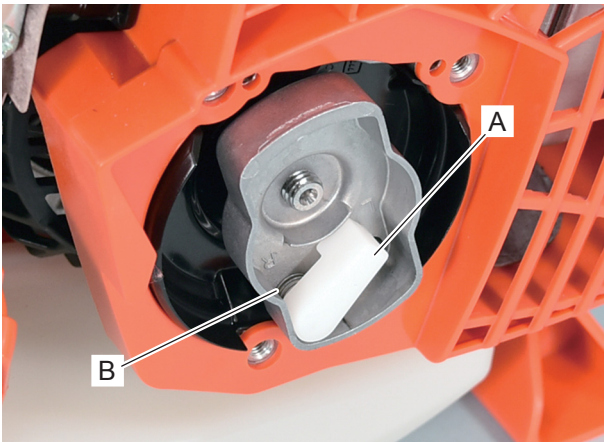

1. Remove starter assembly from unit (Refer to “2-1 Disassembling starter assembly”). Check starter pawl (A) and spring (B). If defective, replace them as follows.

2. Disconnect spark plug cap and remove spark plug. Insert clean rope (C) in spark plug hole to stop crankshaft rotation.

**NOTE:** Do not insert rope end to avoid bite by piston and cylinder.

3. Rotate starter pawl assembly counterclockwise by hand until it cannot be rotated further.

4. Remove starter pawl assembly rotating counterclockwise with 2-pin wrench 897712-04630 (D) as shown.

**NOTE:** Do not use power tools. Otherwise, piston damage may occur.

5. Remove E-ring (E) from pawl, and replace starter pawl (A) and spring (B).

6. Insert spring (B) to pawl and push pawl into hole near mark “R”. Install E-ring (E).

7. Install starter pawl assembly onto crankshaft, rotating clockwise by hand.

8. Tighten starter pawl assembly with 2-pin wrench 897712-04630 (D) as shown.

9. Remove rope (C) from spark plug hole and reinstall spark plug. Reinstall starter assembly.

3 BLOWER SYSTEM

- (A) Fan case grid
- (B) Outer fan case
- (C) Fan
- (D) Inner fan case

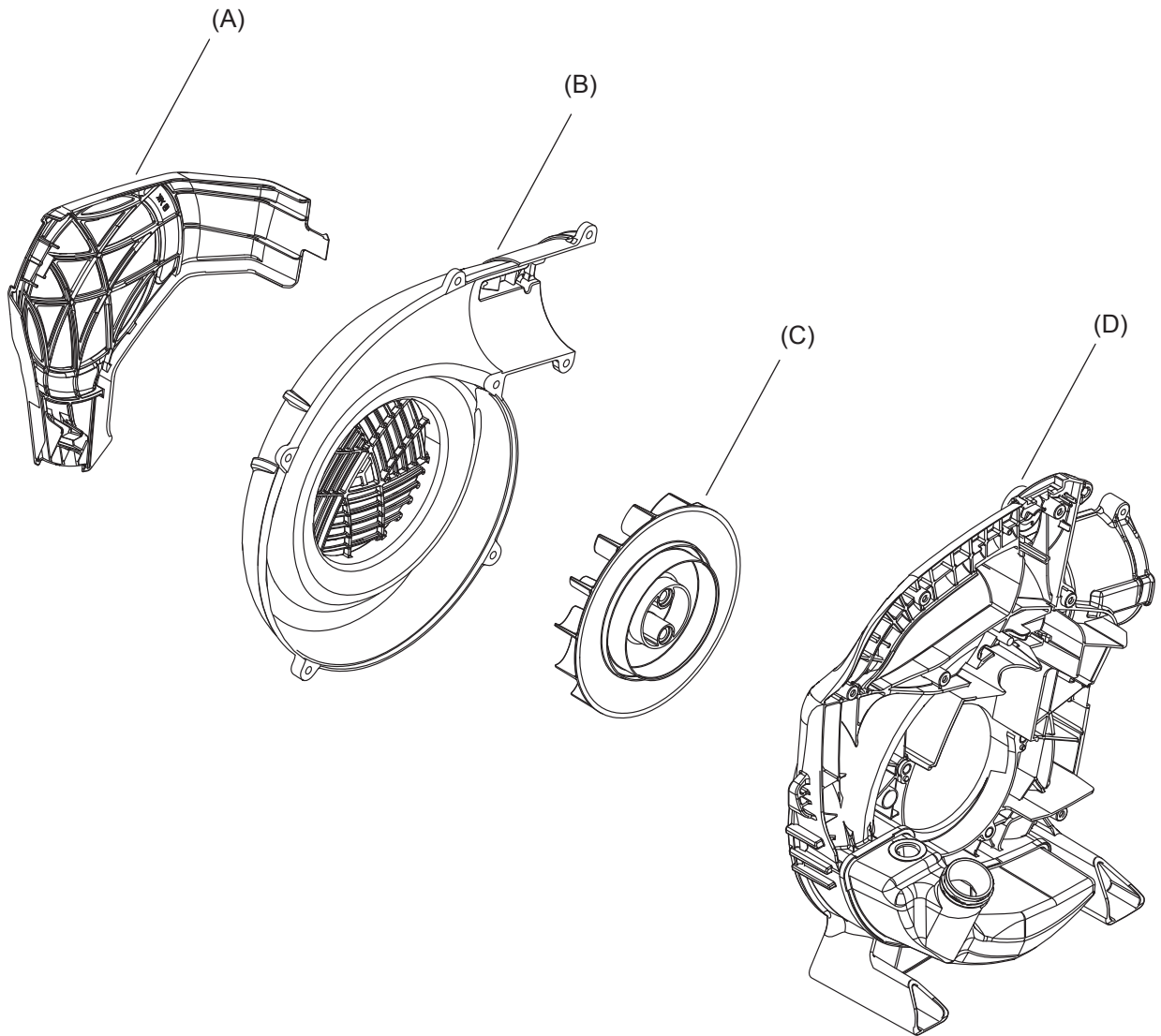



## 3-1 Inspecting fan and fan case



1. Remove blower pipe.
2. Inspect outer fan case (A) and inner fan case (B) for crack or damage. If defective, replace them with new ones (Refer to “3-2 Disassembling fan and fan case”, “3-3 Assembling fan and fan case”).
3. Looking from opening (C) and fan case grid (D), inspect fan and inside fan case for grass or debris.
4. If clogged with grass or debris, remove outer fan case (A) and clean up inside fan case.
5. If defective, replace them with new ones (Refer to “3-2 Disassembling fan and fan case”, “3-3 Assembling fan and fan case”).

## 3-2 Disassembling and assembling fan and fan case



1. Remove blower pipe.
2. Remove seven bolts (A) that secure outer fan case.



3. To remove fan case grid (B), push the tub (b1) on the fan case (C) as shown.

**NOTE:** Do not remove two mounting points on the fan case grid (b2). Removing fan case grid may result in damage to fan case grid (B) and outer fan case (C).

3-2 Disassembling and assembling fan and fan case (continued)

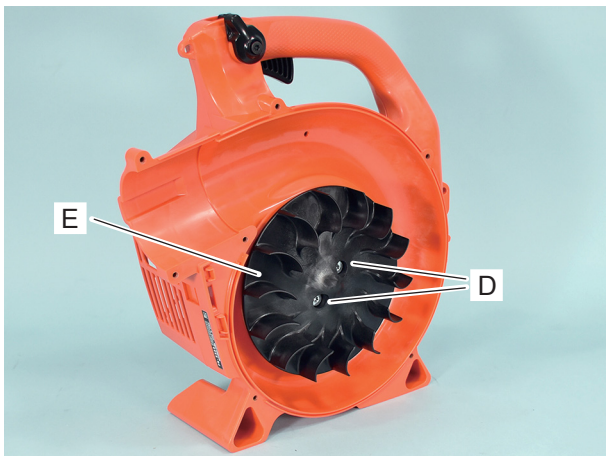

4. Remove two bolts (D).

5. Assemble fan (E) with two bolts (d).

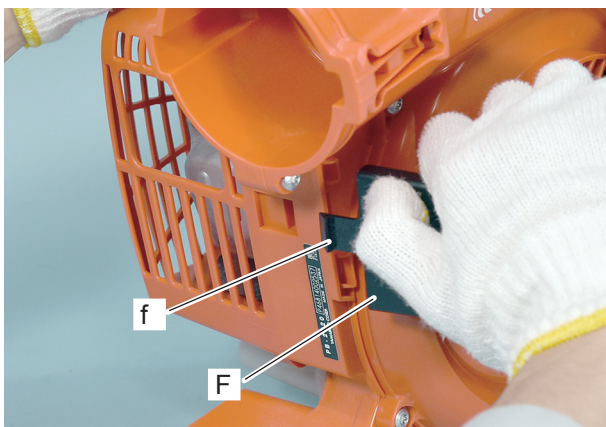

6. Assemble outer fan case with seven bolts. To assemble fan case grid (F), push tab (f) of fan case grid (F) in place.

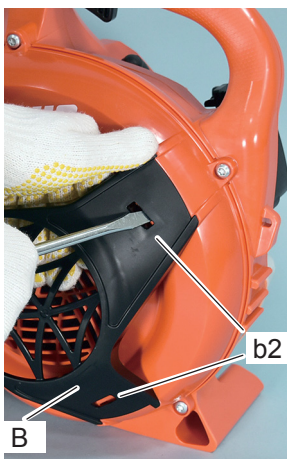

**NOTE:** In the case of replacing the case grid (B), push tab (b2) back and pry up fan case grid (b3) as shown to remove fan case grid. And install fan case grid (B).

### 3-2 Disassembling and assembling fan and fan case (continued)

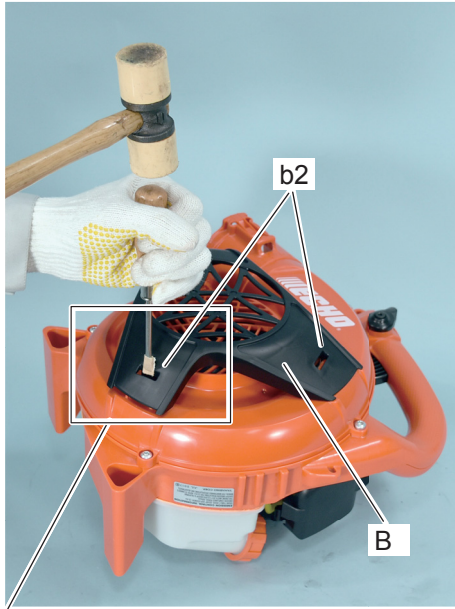

To install fan case grid (B), push tab (b2) on grid (B) with hammer as shown.

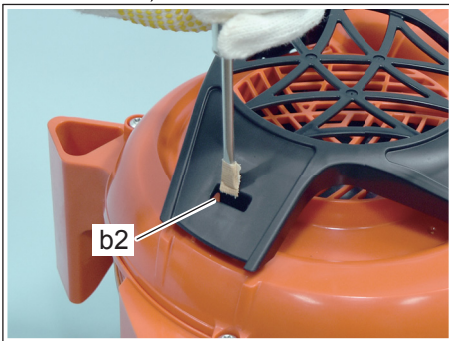

4 IGNITION SYSTEM

- (A) Ignition switch
- (B) Ignition switch knob
- (C) Spark plug cap coil
- (D) Spark plug cap
- (E) Spark plug
- (F) Ignition module
- (G) Flywheel

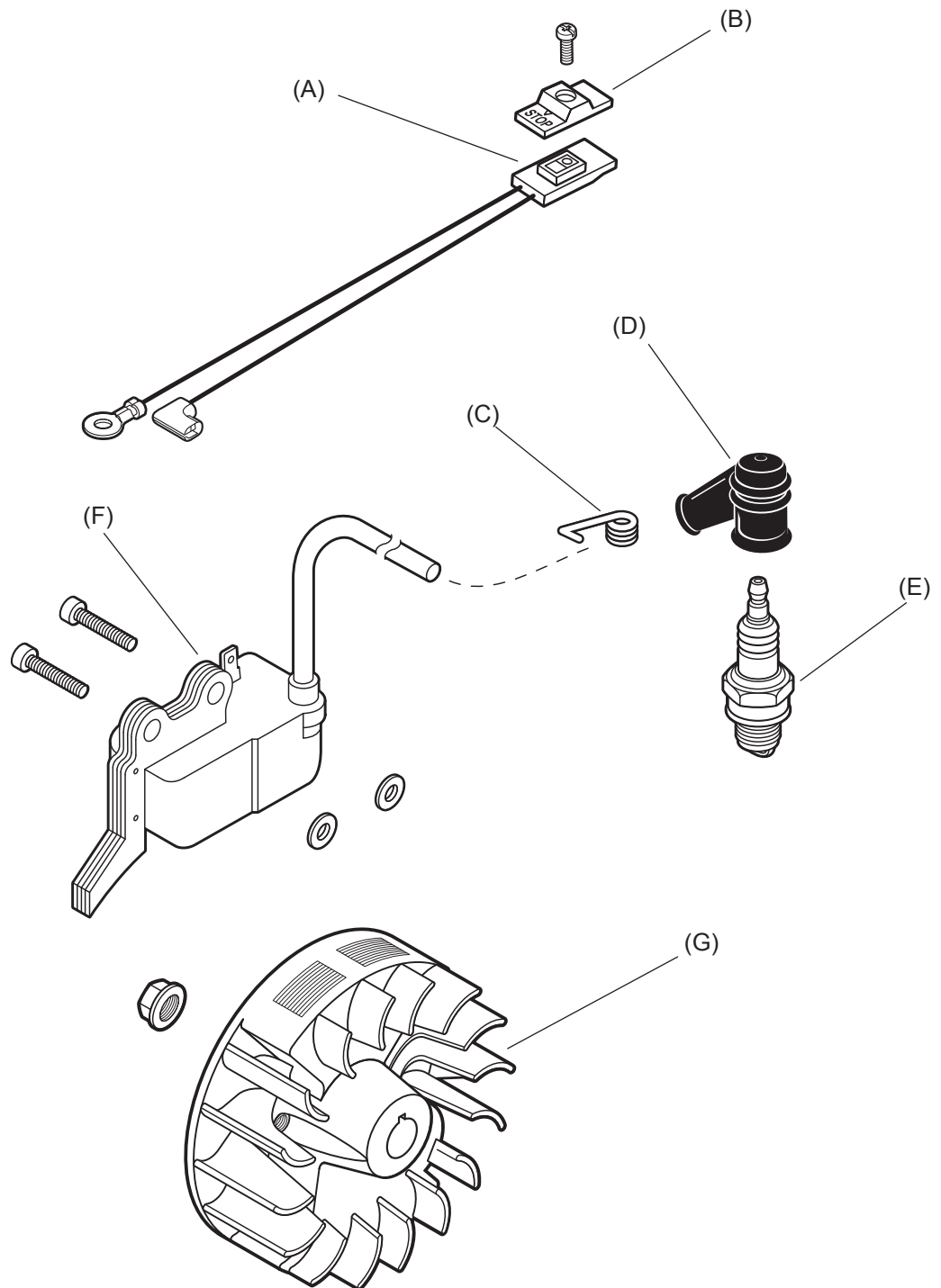

### 4-1 Troubleshooting guide

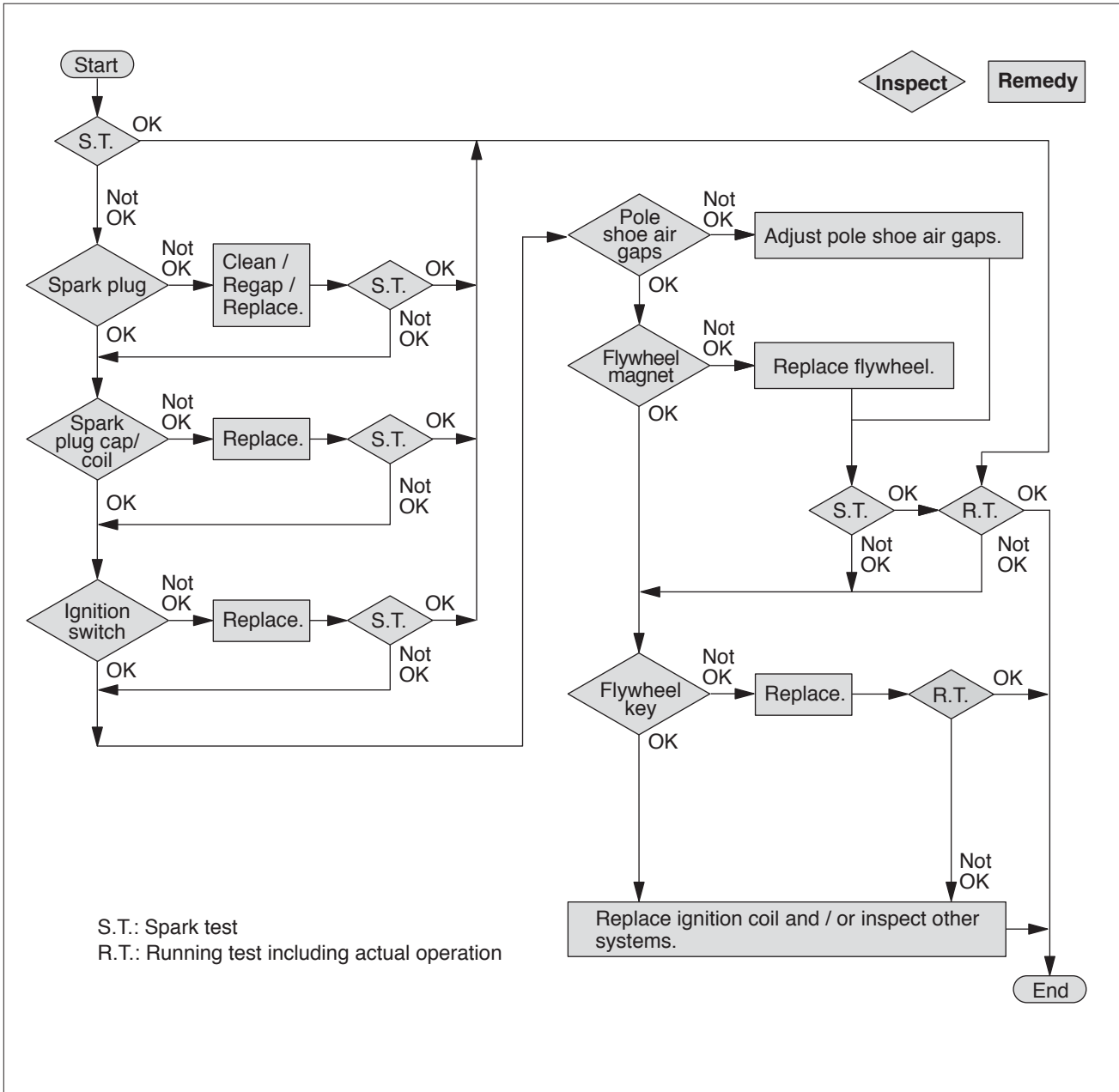



4-2 Testing spark

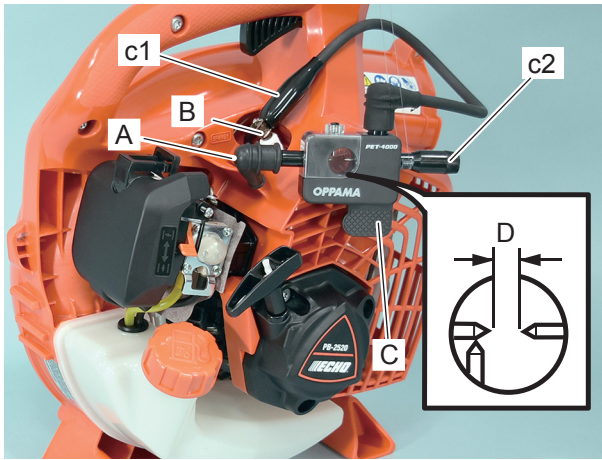

1. Disconnect spark plug cap (A) from spark plug (B).
2. Connect spark plug cap to spark tester 897800-79931 (C), and connect spark tester lead (c1) on spark plug as shown.
3. Screw in adjuster (c2) until the needle tips contact. Turn out adjuster (c2) 4 turns to set spark tester gap (D) to 4 mm (0.16 in).
4. Turn ignition switch forward ("RUN" position). Pull starter grip several times.
5. If spark is steady blue or white at the tester gap, ignition system is considered good.
6. If no spark exists or spark is intermittent in yellow, orange, or red, continue with further inspection.

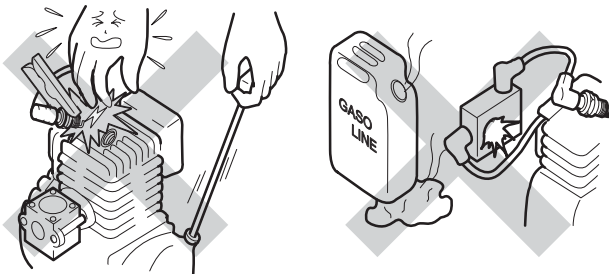

**! DANGER**

- \*Do not test near spark plug hole without spark plug installed, otherwise there is a chance to ignite fuel mixture inside cylinder.
- \*Do not touch metal parts of spark tester while performing the test to avoid receiving electrical shock.
- \*Do not check spark in area where gasoline is spilled or flammable gases may exist.

4-3 Inspecting spark plug

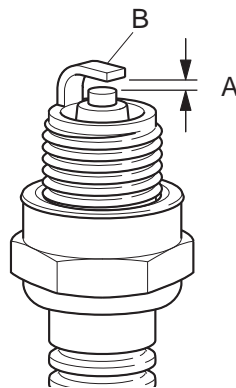

1. Remove spark plug to inspect for fouling, cracked or broken insulator, cracked outer electrode, or rounded center electrode. Clean or replace spark plug as required.

2. Set spark plug gap (A) by bending outer electrode (B).

Standard : 0.6 to 0.7 mm (0.024 to 0.028 in)

**NOTE:** Take care not to crack outer electrode when bending.

3. If engine does not start with correct spark plug, inspect if spark plug is wet or dry. If it is excessively wet or dry, inspect fuel system.

## 4-4 Replacing spark plug cap and coil

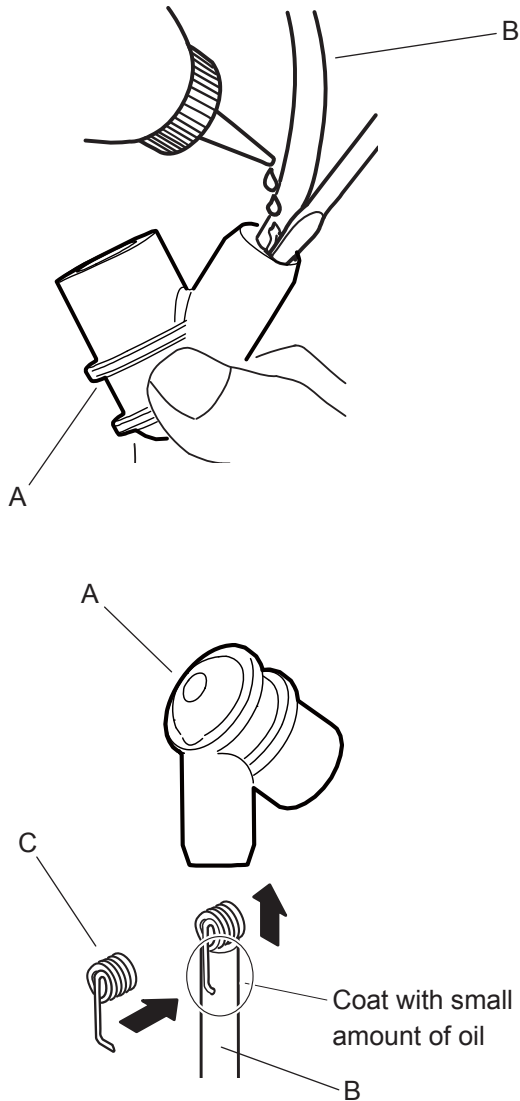

1. Disconnect spark plug cap (A) from spark plug.
2. Apply some oil in spark plug cap (A) for easy removal from high tension lead (B).
3. Pull spark plug cap away from high tension lead.
4. Inspect spark plug cap coil (C) for corrosion and correct connection. Inspect spark plug cap for cracks. Replace as required.

**NOTE:** Make sure spark plug cap coil (C) contacts center core of high tension lead when reinstalling it.

5. Coat end of high tension lead (B) with small amount of oil, and insert it into spark plug cap (A) as shown, until the spark plug cap coil is properly seated in the cap.

4-5 Inspecting ignition module

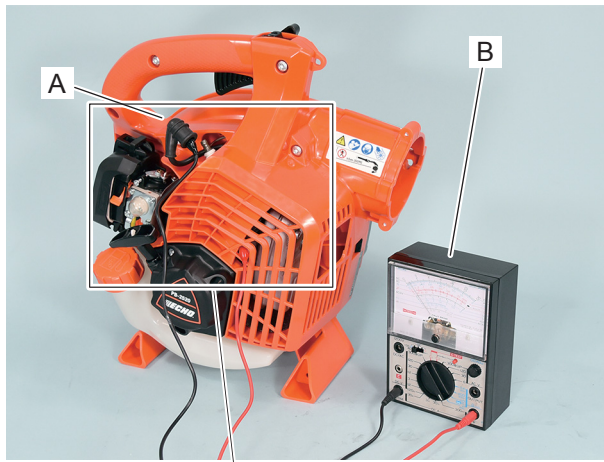

1. Remove spark plug cap (A) from spark plug.

2. Connect black probe (b1) of Ohm-meter or multimeter (B) to spark plug cap coil in spark plug cap (A).

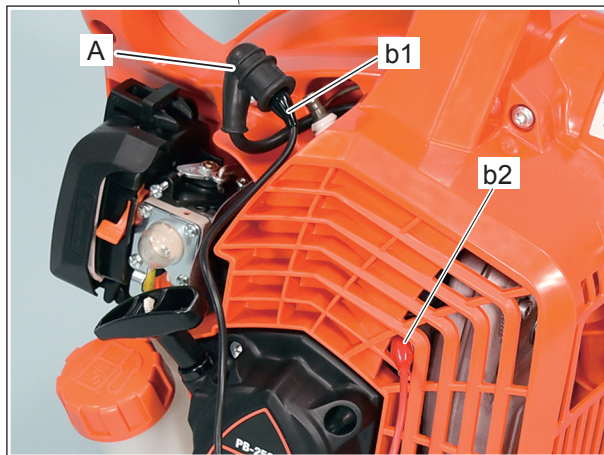

3. To measure secondary coil resistance, contact cylinder fin with red probe (b2). Secondary coil resistance should be in the range of 960 to 1,000  $\Omega$ .

4. If the meter reading indicates infinite resistance, remove spark plug cap and spark plug cap coil, and measure resistance between the conduction wire of high tension lead and ignition module core.

5. If the reading at step 3 or 4 is not in the range of 960 to 1,000  $\Omega$ , replace with a new ignition module (Refer to "4-6 Replacing ignition module").

## 4-6 Replacing ignition module

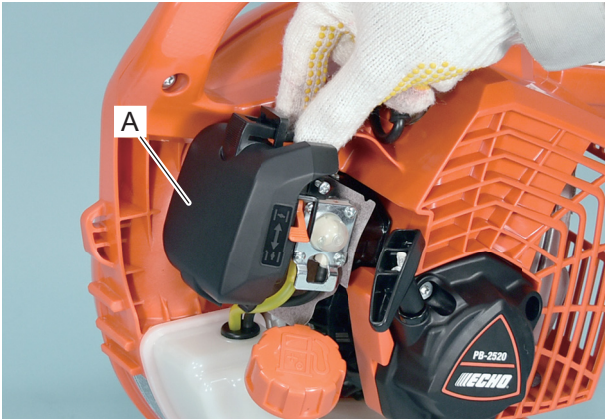

1. Remove air cleaner cover (A) as shown.

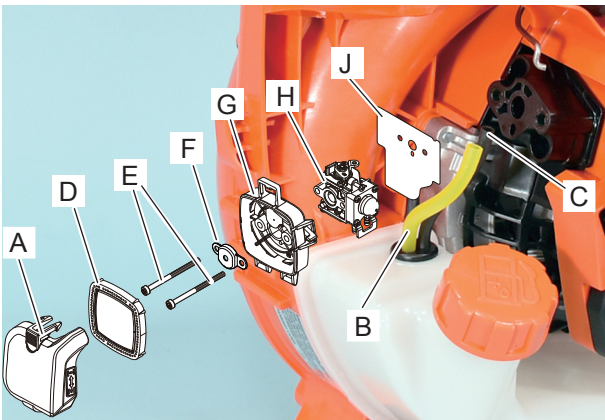

2. Disconnect fuel line (B) and fuel return line (C) from carburetor(H).

3. Remove air filter (D), two bolts (E), prevent plate (F), air cleaner case (G), carburetor (H) and intake gasket (J).

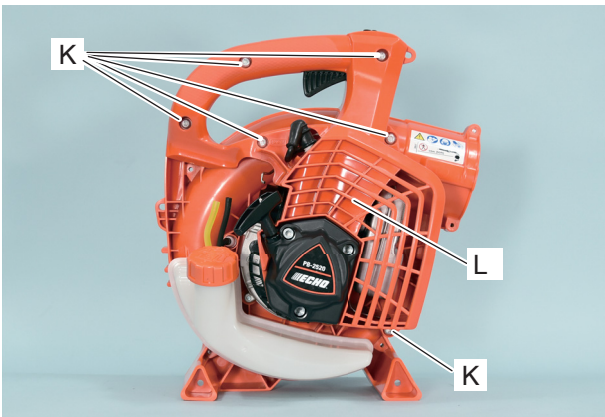

4. Remove starter case referring to “2-1 Disassembling starter assembly”.

5. Remove six bolts (K) and engine cover (L).

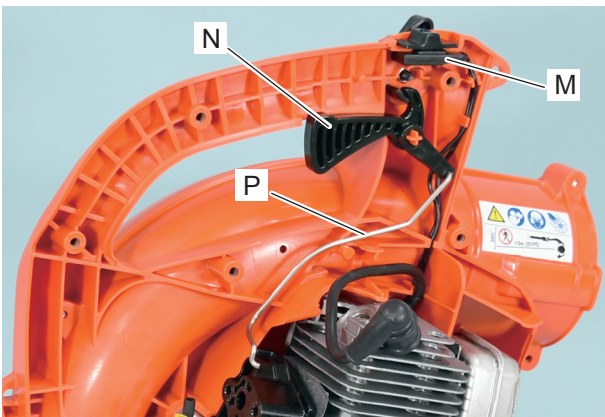

6. Remove ignition switch (M), throttle trigger (N) and throttle rod (P).



4-6 Replacing ignition module (continued)

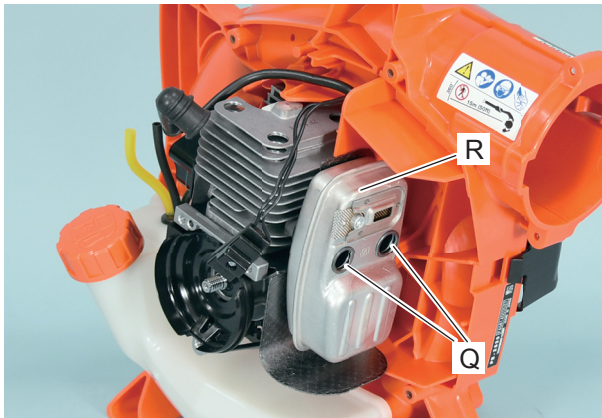

7. Remove two bolts (Q) and muffler (R).

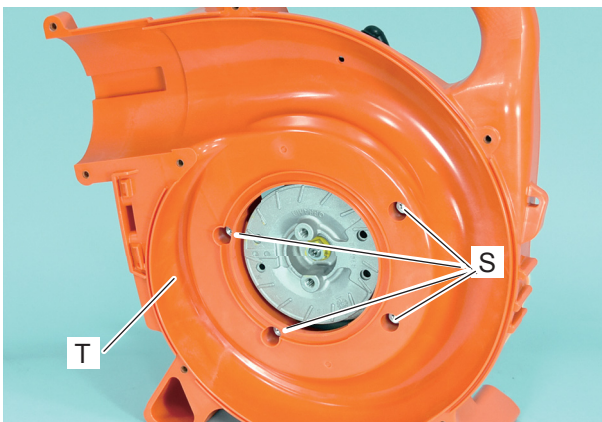

8. Remove outer fan case and fan referring to “3-2 Disassembling fan and fan case”.

9. Remove four bolts (S) and engine assembly from inner fan case (T).

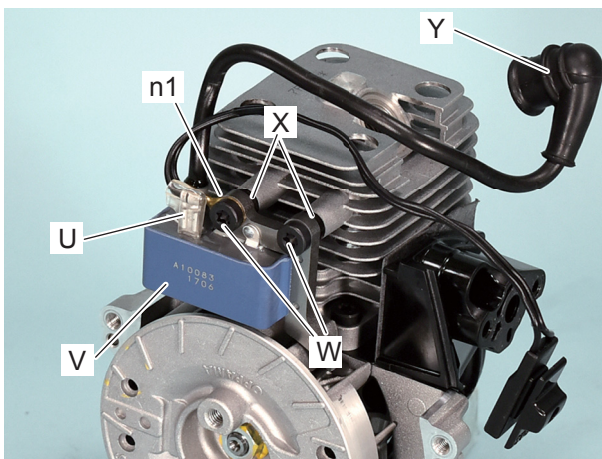

10. Remove primary lead terminal (U) from ignition module(V).

11. Remove two bolts (W), ignition switch terminal (n1), remove ignition module (V) and two washer (X) from cylinder.

12. Remove spark plug cap (Y) and spark plug cap coil from high tension lead.(Refer to 4-4”Replacing spark plug cap and coil”) Install them on new ignition module (V).

13. Loosely install new ignition module (V), ignition switch terminal (n1) and two washer with two bolts. Set air gap (Refer to “4-6 Setting pole shoe air gaps”). Tighten two bolts (W).

14. Connect primary lead terminal (U) on ignition module (V).

## 4-7 Setting pole shoe air gaps

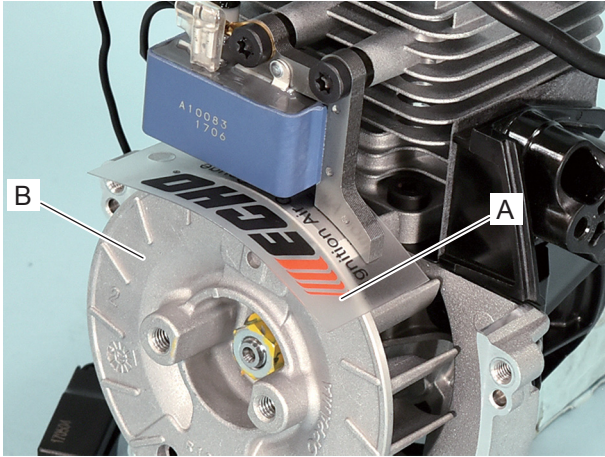

1. Insert Module air gap gauge: 91004 (A) or 0.3 - 0.4 mm (0.012 - 0.016 in) thick feeler gauge between flywheel (B) and ignition module shoes.
2. Rotate flywheel until magnetic poles of flywheel face ignition module shoes.
3. Hold ignition module against flywheel and tighten the bolts to specified torque (Refer to "Service information 1-3 Torque limits"). After tightening bolts, remove Module air gap gauge: 91004 (A) (or feeler gauge).

**NOTE:** When air gap is too narrow, contact with flywheel may result. When the air gap is too wide, spark is weak.

## 4-8 Inspecting ignition switch

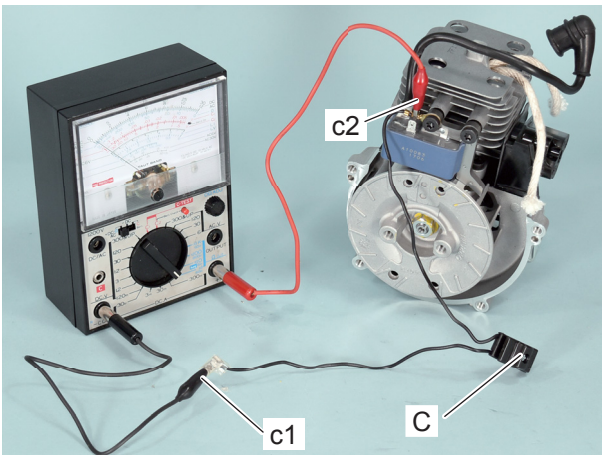
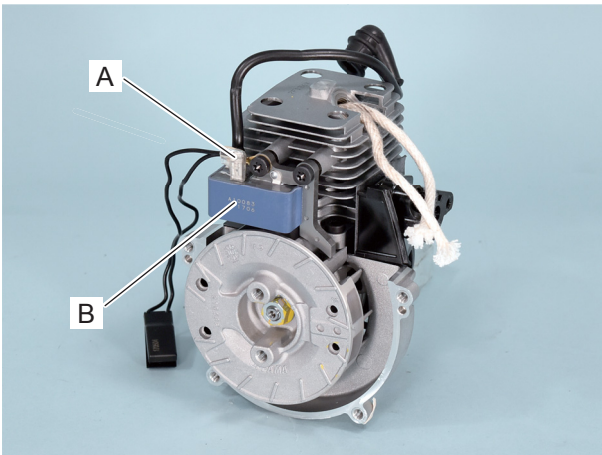

1. Referring to "4-6 Replacing ignition module", remove engine assembly from inner fan case.
2. Remove primary lead terminal (A) from ignition module (B).
3. Connect one probe of Ohm-meter or multi-meter to terminal (c1) of ignition switch (C). Connect the other probe to the other terminal (c2) of ignition switch.
4. When ignition switch is upward ("RUN" position), tester should indicate infinite resistance.
5. When ignition switch is in "STOP" position, tester should show that the circuit is in conducting state (closed circuit).
6. If ignition switch is defective, replace with a new one.

4-9 Replacing ignition switch

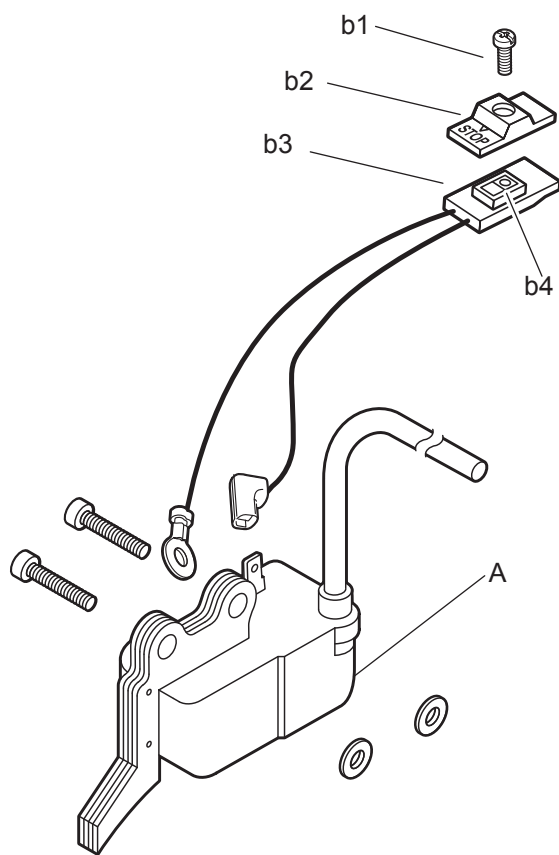

1. Remove ignition module (A). (Refer to 4-6 "Replacing ignition module")

**NOTE:** When replacing ignition switch knob (b2) and ignition switch (B), begin from step 2. When replacing entire ignition switch (B), go to step 4.

2. Remove screw (b1). Remove ignition switch knob (b2).

3. Apply a drop of thread locking sealant (Loctite #222, ThreeBond 1342 or equivalent) in the screw hole (b4) of ignition switch. Assemble switch knob (b2) and lead terminal (b3) with screw (b1).

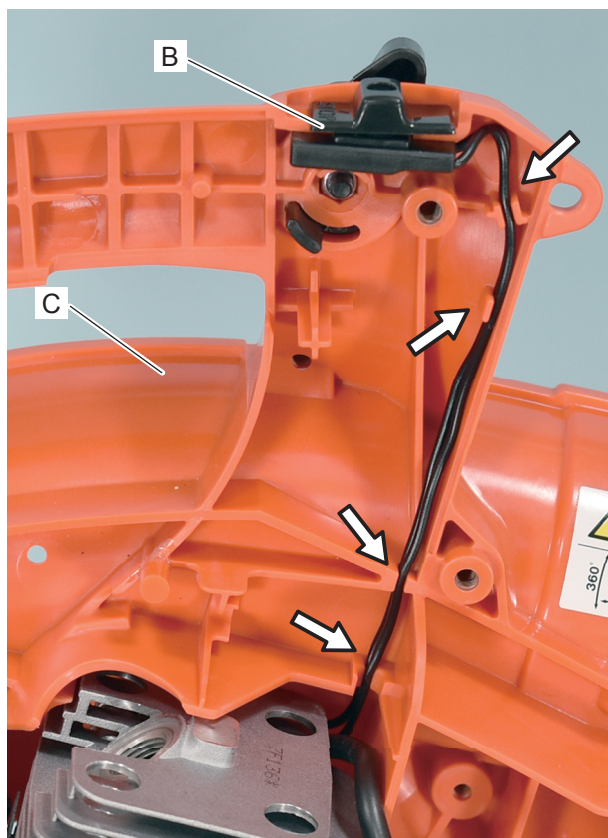

4. Install ignition switch (B) on inner fan case (C). Install each lead in ribs of inner fan case as shown.



## 4-10 Inspecting flywheel magnetic force



1. Inspect magnetic force of flywheel (A) using flux meter, or bridging with a screwdriver (B) as shown.

2. If magnetic force is weak, replace flywheel referring to “4-11 Replacing flywheel and key”.

## 4-11 Replacing flywheel and key

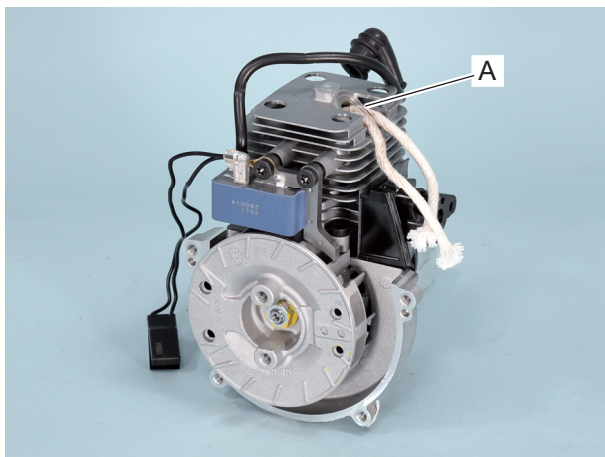

1. Referring to “4-5 Replacing ignition module“, remove engine assembly from inner fan case.

2. Remove spark plug cap and clean dirt around spark plug. Remove spark plug.

3. Insert clean rope (A) in spark plug hole adequately to stop crankshaft rotation.

**NOTE:** Do not insert rope end to avoid bite by piston and cylinder.

**NOTE:** Do not use piston stopper to avoid piston damage.

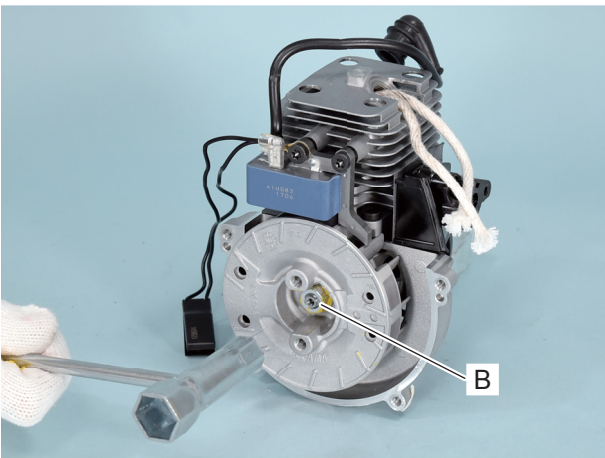

4. Remove nut (B) counterclockwise with plug wrench.



4-11 Replacing flywheel and key(continued)

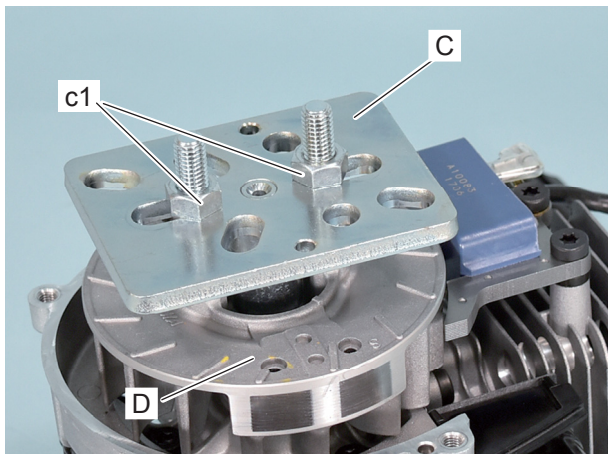

5. To remove flywheel(D), set puller Y089-000111 (C) on flywheel (D) as shown.

6. Tighten two nuts (c1) on the puller alternately to remove flywheel (D).

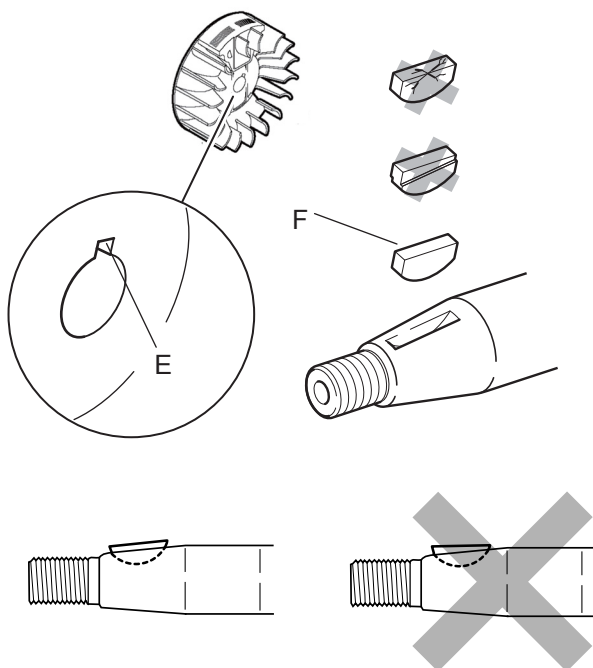

7. Check cast groove (E) and woodruff key (F) for damage. Replace with a new one if deformed.

8. Wipe off oil from taper part of crankshaft and flywheel before assembling flywheel.

9. Install woodruff key into key groove as shown in the picture.

**NOTE:** If key groove is too tight, file woodruff key before installation.

10. Align flywheel cast groove with woodruff key on crankshaft.

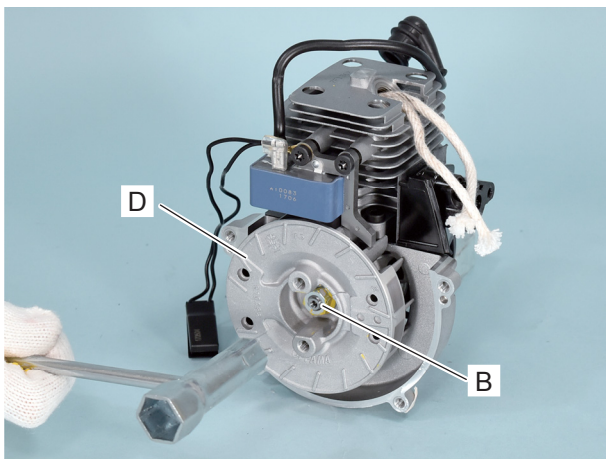

11. Insert flywheel (D) and tighten nut (B) to specified torque (Refer to "Service information 1-3 Torque limits").

**NOTE:** Be sure not to exceed specified torque. Otherwise, flywheel deformation will result.

## 5 HANDLE AND CONTROL SYSTEM

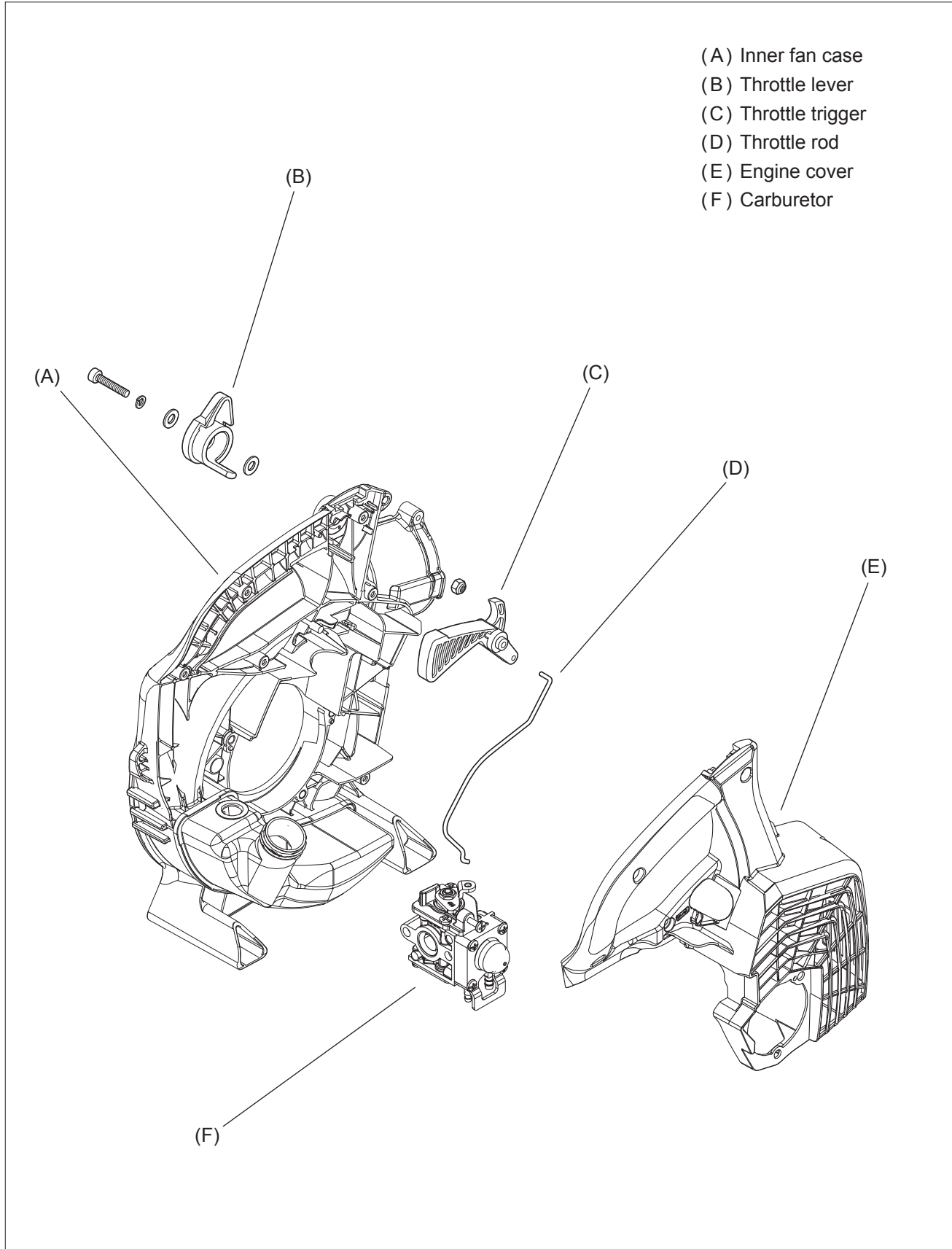

5-1 Disassembling and assembling handle and control parts

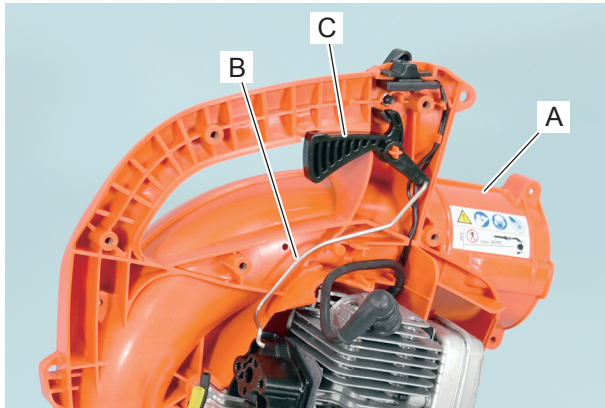

1. Remove engine cover from inner fan case (A) (Refer to “4-6 Replacing ignition module”).
2. Remove throttle rod (B) from throttle trigger (C).
3. Remove throttle trigger (C) from inner fan case (A).

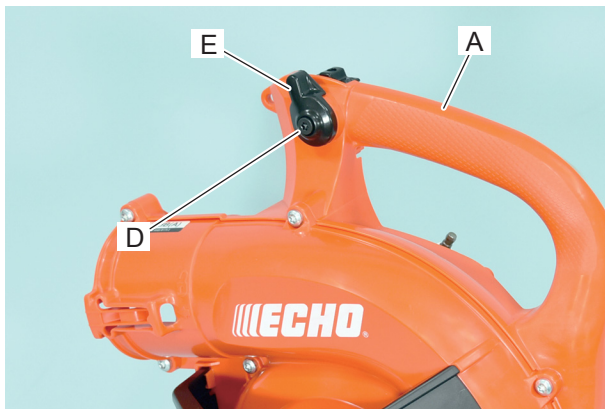

4. Remove bolt (D) with spring washer, two washers, throttle lever (E) and nut from inner fan case (A).
5. Inspect throttle rod (B), throttle trigger (C) and throttle lever (E) for wear, damage or deformation. Replace as required.

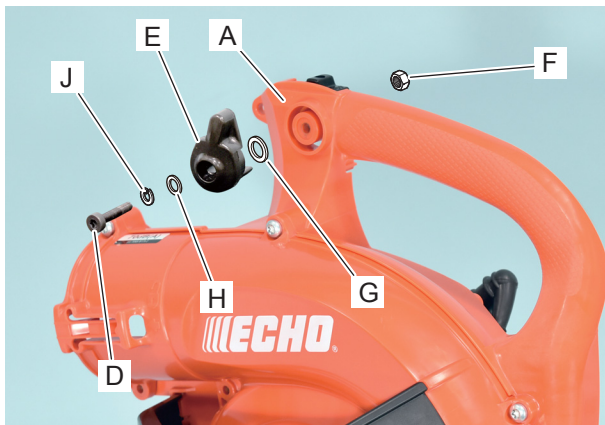

6. Set nut (F) on inner fan case (A).
7. Assemble washer (G), throttle lever (E), washer (H) and spring washer (J) with bolt (D) on inner fan case (A).

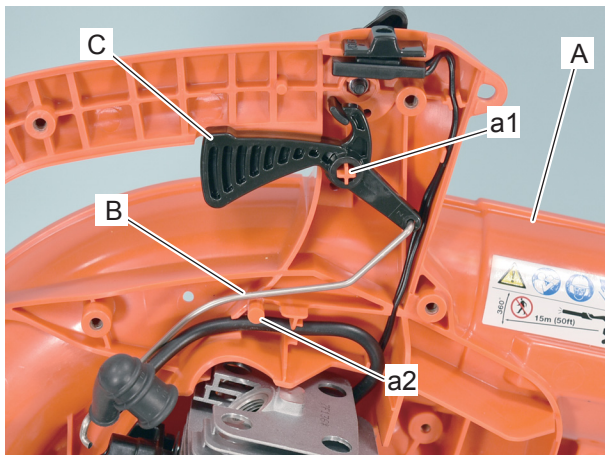

8. Set throttle trigger (B) on boss (a1) of inner fan case (A) as shown.
9. Apply lithium grease with boss (a2).
10. Set throttle rod (B) on throttle trigger (C).
11. Reinstall all removed parts.

### 6 FUEL SYSTEM

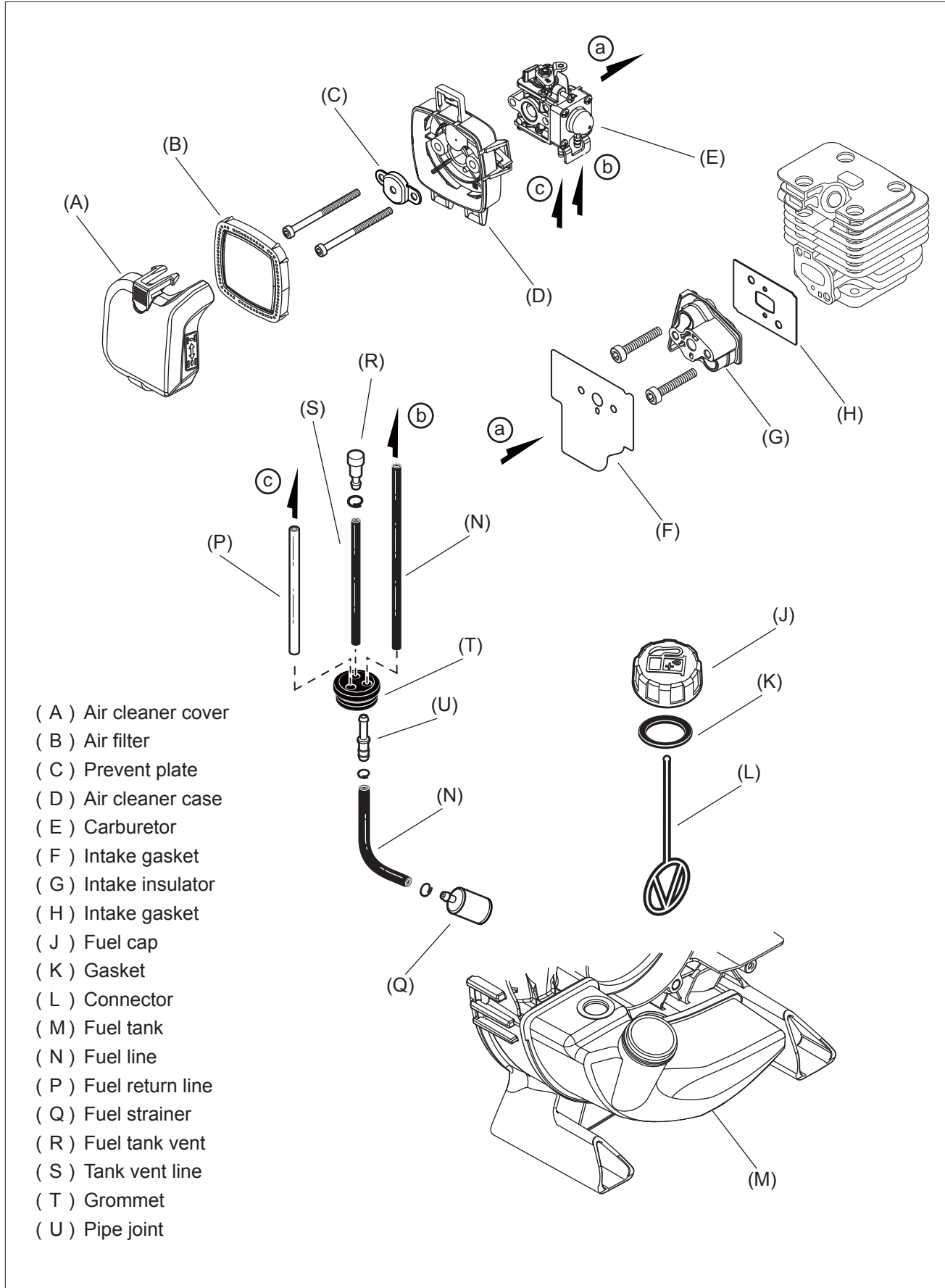

- ( A ) Air cleaner cover
- ( B ) Air filter
- ( C ) Prevent plate
- ( D ) Air cleaner case
- ( E ) Carburetor
- ( F ) Intake gasket
- ( G ) Intake insulator
- ( H ) Intake gasket
- ( J ) Fuel cap
- ( K ) Gasket
- ( L ) Connector
- ( M ) Fuel tank
- ( N ) Fuel line
- ( P ) Fuel return line
- ( Q ) Fuel strainer
- ( R ) Fuel tank vent
- ( S ) Tank vent line
- ( T ) Grommet
- ( U ) Pipe joint



6-1 Inspecting air filter



1. Close choke shutter. Remove air cleaner cover and air filter.

2. Inspect air filter. If blocked with dirt or dust, remove the obstruction with compressed air or brush.

**WARNING**  **DANGER**  
Wear eye protection when working with compressed air. Eye damage can occur from flying particles.

3. If heavily blocked with dirt or dust, or if heavily soiled or damaged, replace air filter with new one.

6-2 Inspecting fuel cap and fuel strainer

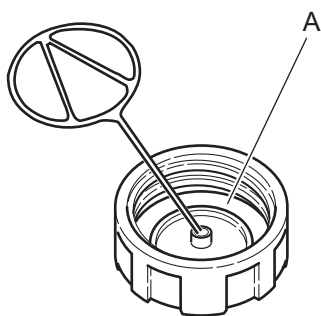

1. Remove fuel cap.

2. Inspect fuel cap for cracks and gasket (A) for cuts or damage, and replace with new one as required.

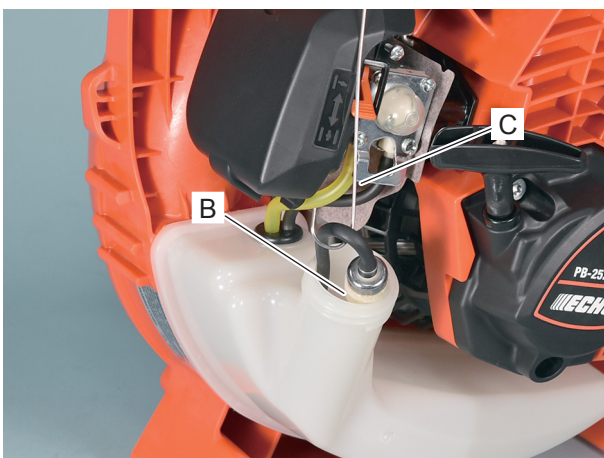

3. Pull fuel strainer (B) out from fuel tank using a wire hook (C). Clean fuel strainer. Replace with new one if defective or heavily soiled.

4. Reinstall fuel cap.

## 6-3 Inspecting fuel tank and line

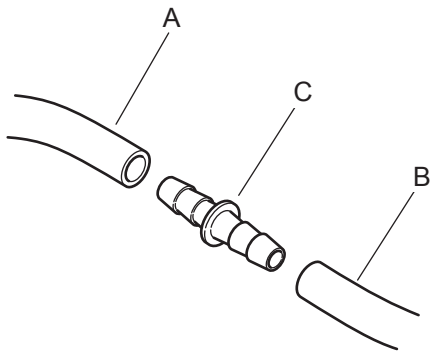
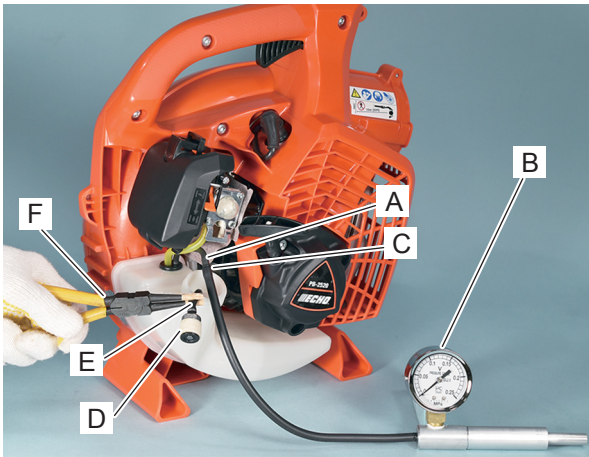

1. Clean fuel tank inside as required.
  2. Disconnect black fuel line (A) from carburetor and connect pressure tester 897803-30133 (B) to fuel line (A) by pipe joint V186-000510 (C).
  3. Remove fuel cap and pull out fuel strainer (D) from fuel tank.
  4. Pinch fuel line (E) with longnose pliers (F) as shown.
- NOTE:** Wrap the ends of longnose pliers with tape (or cover with soft pipes) to protect fuel line from damage.
5. Apply pressure approx. 50 kPa (0.5 kgf/cm<sup>2</sup>) (7 psi).
  6. If pressure drops, replace fuel line.

7. Put fuel strainer in fuel tank and fasten fuel cap securely.
8. Apply pressure approx. 10 kPa (0.1 kgf/cm<sup>2</sup>) (1.4 psi).
9. Pressure should not drop. If pressure drops, leakage may occur from fuel cap, fuel cap O-ring, mating surface of fuel tank, grommet, or tank vent. Inspect and replace defective part(s) with new one.
10. Remove pressure tester and connect fuel line (A) to carburetor.

6-4 Inspecting and replacing tank vent

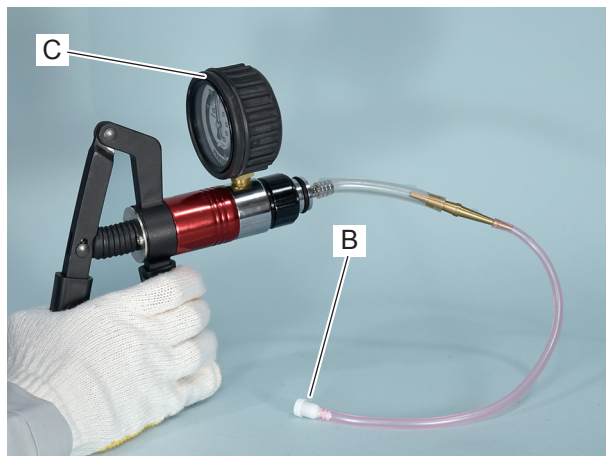
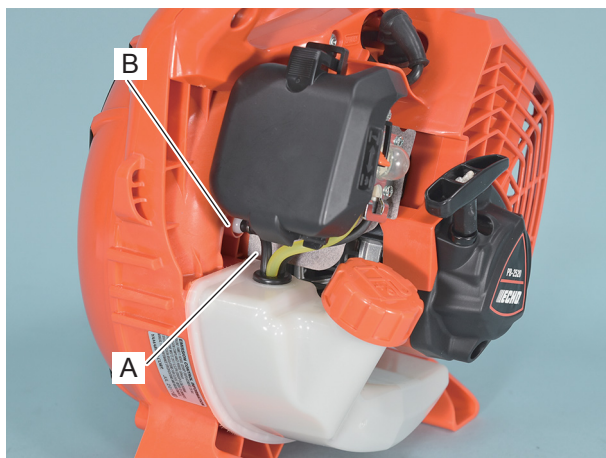

**NOTE:** Tank vent prevents a vacuum from forming in fuel tank when fuel in fuel tank is being consumed. When pressure in fuel tank becomes too high, tank vent releases the pressure.

1. Pull tank vent line (A) and remove tank vent (B).

2. Connect pressure tester 91139 (C) to tank vent (B).

3. Apply pressure approx. 50 kPa (0.5 kgf/cm<sup>2</sup>) (7 psi). Make sure pressure is stable in range of 10 - 40 kPa (0.1 - 0.4 kgf/cm<sup>2</sup>) (1.4 - 5.7 psi).

4. If it is not in the range, gently clean tank vent with compressed air or replace with new one.

**NOTE:** Do not disassemble valves in tank vent assembly. Damage to valves will occur.

5. Apply negative pressure 5.8 inHg (20 kPa) (0.2 kgf/cm<sup>2</sup>) (3 psi).

6. Tank vent should pass air freely without holding any pressure. If it does not, replace tank vent with new one.

## 6-4 Inspecting and replacing tank vent (continued)

**NOTE: Inspection using 897803-30133**

If pressure tester 91139 is not available, tank vent can be inspected with pressure tester 897803-30133 as follows.

1. Connect tank vent (A) to pressure tester 897803-30133 (B).

2. Apply pressure approx. 50 kPa (0.5 kgf/cm<sup>2</sup>) (7 psi). Make sure pressure is stable in range of 10 - 40 kPa (0.1 - 0.4 kgf/cm<sup>2</sup>) (1.4 - 5.7 psi).

3. If it is not in the range, gently clean tank vent with compressed air or replace with new one.

**NOTE:** Do not disassemble valves in tank vent assembly. Damage to valves will occur.

4. Remove cap (C) of tank vent, and clean sponge (D).

5. Cut pipe 363011-00210 (E: 7x11x170mm) and 382011-01110 (F: 9x13x350) in approx. 30mm (1 1/4 in) length, and connect them to pressure tester as shown. Connect tank vent (A) without cap to pipe as shown.

6. Plug hole (a) with finger and apply pressure 20 kPa (0.2 kgf/cm<sup>2</sup>) (3 psi). The pressure should hold steady.

7. Remove finger from hole (a). Tank vent should pass air freely without holding any pressure. If it does not, replace tank vent with new one.

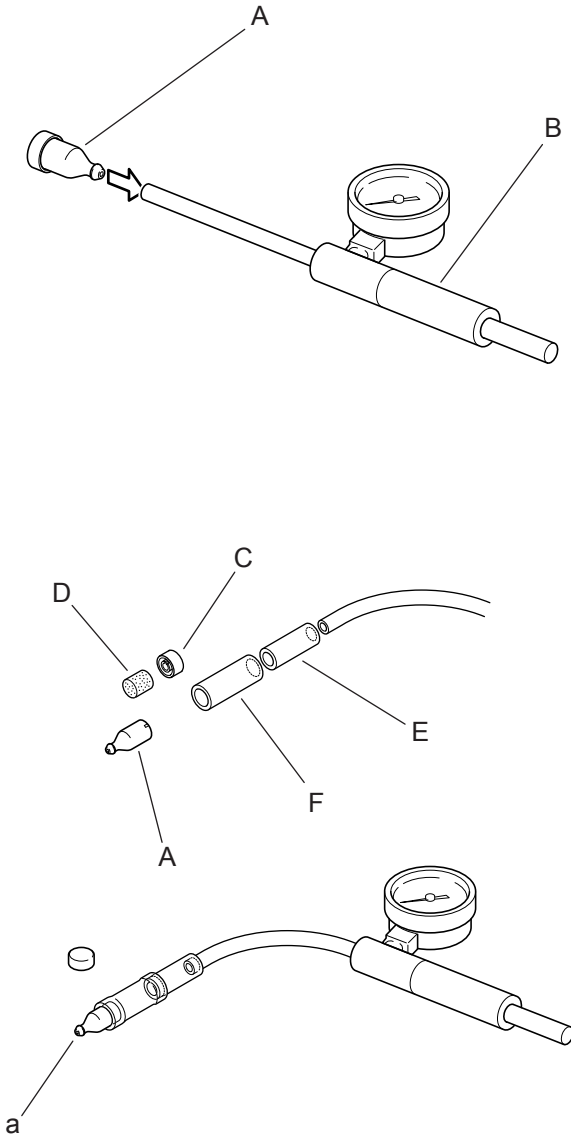



6-5 Replacing fuel line, fuel return line, tank vent line and grommet

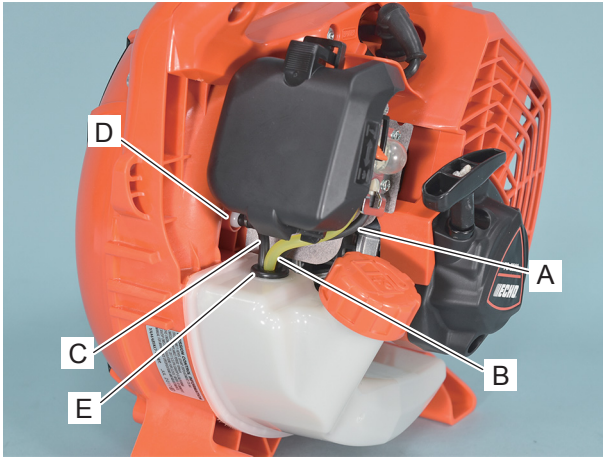

1. Disconnect fuel line assembly (A) and fuel return line (B) from carburetor.
2. Pull tank vent line (C) and remove tank vent (D).
3. Remove grommet (E) together with fuel line assembly (A), fuel return line (B) and tank vent line (C). Fuel strainer can be directly pulled out through grommet hole.
4. Remove fuel strainer from fuel line assembly.
5. Remove fuel line (A), fuel return line (B) and tank vent line (C) from grommet (E). If lines and grommet are defective, replace with new ones.

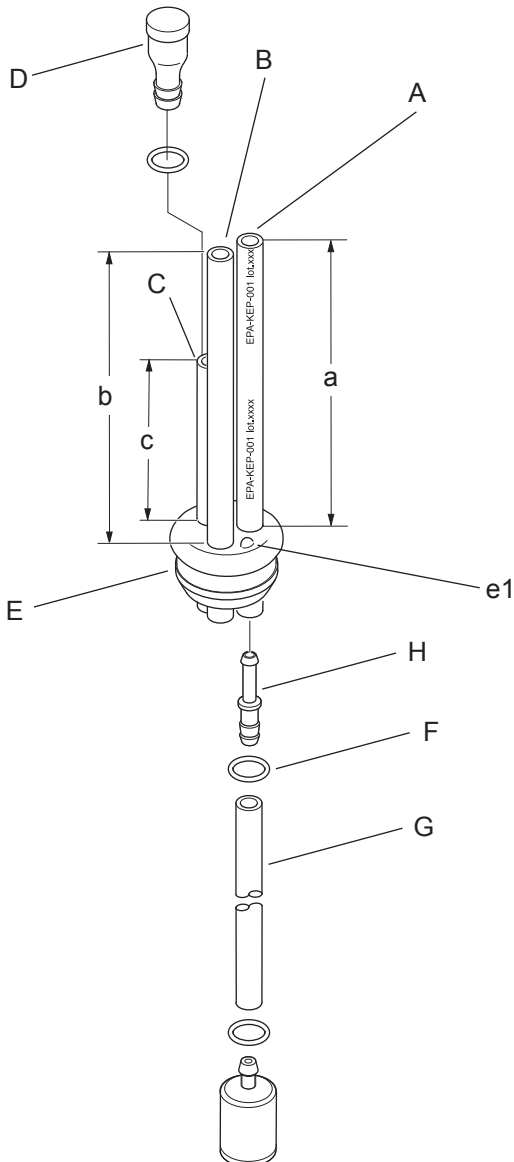

6. Insert fuel line (A), fuel return line (B) and tank vent line (C) to grommet (E). Adjust each length as follows:

Line		(A)	(B)	(C)
		Black (Strainer)	Trans-parent (Return)	Black (Vent)
Length	mm (inch)	80 (3.15)	85 (3.35)	60 (2.36)
Distance		(a)	(b)	(c)
	mm (inch)	66 ~ 68 (2.60~2.68)	66 ~ 68 (2.60~2.68)	35 ~ 37 (1.38~1.46)

**NOTE:** Pay attention to the position of grommet projection (e1)

**NOTE:** Make sure fuel line (a1) has ID mark "EPA-KEP-001 lot.xxxx" on it.

7. Place clip (F) over fuel line (G) then install fuel line (G) to pipe joint (H) and secure with clip (F). Connect pipe joint (H) with fuel line (G) to fuel line (A).
8. Connect fuel strainer to fuel line (G). Connect tank vent (D) to tank vent line (C). And then install grommet (E) to fuel tank, together with fuel line assembly, fuel return line (B) and tank vent line (C).
9. Set tank vent (D) in place. Connect fuel line (A) and fuel return line (B) to carburetor.

**6-6 Adjusting carburetor****6-6-1 General adjusting rules**

A. Before adjustment, check the following items.

1. The correct spark plug must be clean and properly gapped.
2. The air filter element must be clean and properly installed.
3. The muffler exhaust port must be clear of carbon.
4. The fuel lines, tank vent and fuel filter are in good condition and clear of debris.
5. The fuel is fresh ( > 89 octane :  $\frac{RON+MON}{2}$  ) and properly mixed at 50 : 1 with "ISO L-EGD" or "JASO M345-FD" 2-stroke oil.
6. All blower pipes are installed for proper engine loading.

B. Preliminary adjustment : Adjustment by Throttle adjust screw of carburetor.

Start and run engine for 10 seconds at idling and then run for 180 seconds at WOT. Verify idle engine speed ranges from 2,800 to 3,200 RPM, and WOT engine speed is over 7,150 RPM. If idle engine speed is out of range, adjust throttle adjust screw to 2,800 - 3,200 RPM. Make sure WOT engine speed is over 7,150 RPM again. If engine does not run correctly after this adjustment, proceed to the next step 6-6-2.

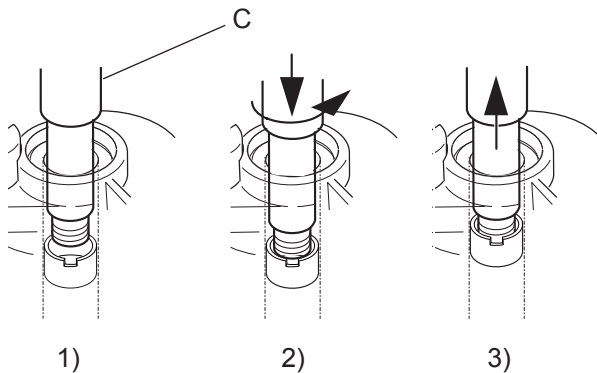
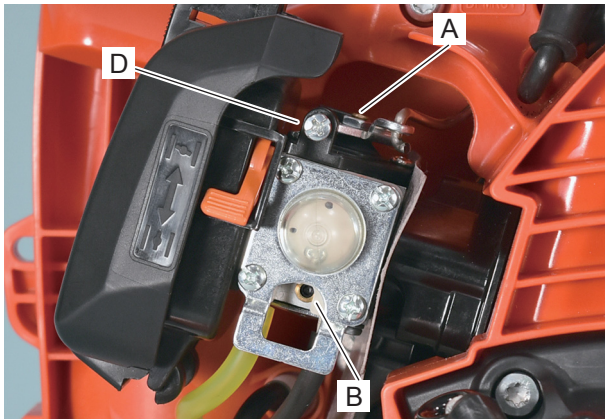
**6-6-2 Initial setting Throttle adjust screw, L mixture needle and H mixture needle**

Tools Required: P/N G310-000050 Tachometer PET-304, P/N Y089-000094 Carburetor adjustment tool KIT (Driver(2.5mm)), P/N 91077 Limiter cap remover KIT(Limiter plug tool)

Parts Required: (2) limiter plugs P/N P005-001270.

1. Remove plugs from L mixture needle hole (A) and H mixture needle hole (B) using limiter plug tool (C) as follows.

1) Put limiter plug tool (C) on limiter plug in mixture needle hole.

2) Screw limiter plug tool counterclockwise (CCW) 2 turns into limiter plug pushing the tool against the plug to engage tool threads.

3) Pull out limiter plug tool, with the limiter plug, from mixture needle hole.

4) Repeat plug removal procedure for the other mixture needle.

**NOTE:** If the plug is damaged and left in the hole, use a needle or pin-shaped tool to remove deformed plug pieces.

6-6-2 Initial setting Throttle adjust screw, L mixture needle and H mixture needle (continued)

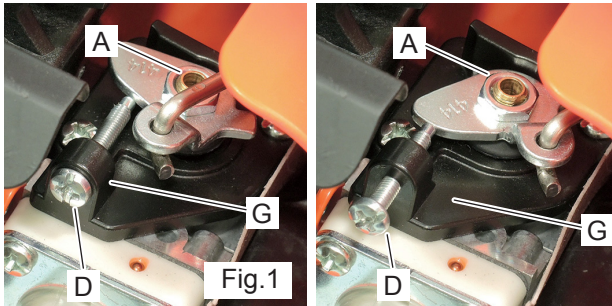

2. Turn H mixture needle (B) clockwise (CW) until lightly seated. And then turn H mixture needle CCW 1 3/4 turns. Turn L mixture needle (A) clockwise until lightly seated. And then turn L mixture needle CCW 2 1/2 turns.

3. Turn Throttle adjust screw (D) CW until its head touches boss (G) as shown in Fig.1. Then turn Throttle adjust screw (D) CCW 13 turns.

**NOTE :** The initial carburetor settings for Throttle adjust screw, L and H mixture needles are intended to start and run the engine before final carburetor adjustments are made to conform the unit to meet Emission Regulations. The actual number of turns needed for engine operation may vary.

6-6-3 Adjusting carburetor

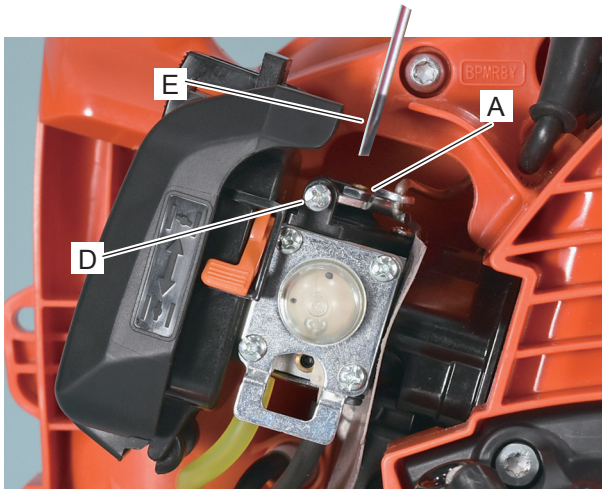

1. Start and run engine for 10 seconds at idling and then run for 180 seconds at WOT.

2. Adjust L mixture needle (A) using 2.5 mm blade screwdriver (E) to reach maximum engine speed just before lean drop off .

3. Set idle speed to 3,500 RPM by turning Throttle adjust screw (D). Engine RPM should be stable at 3,500 RPM after Throttle adjust screw adjustment.

4. Turn L mixture needle (A) CCW to reduce idle speed 500 RPM to set idle speed at 3,000 RPM. The idle speed range is 2,800 to 3,200 RPM.

**NOTE :** Engine speed must be allowed to stabilize a minimum of 20 seconds after each adjustment of L mixture needle to assure accurate tachometer readings.

5. Adjust H mixture needle (B) to obtain maximum WOT engine speed just before lean drop off using 2.5mm blade screwdriver (E).

6. Turn H mixture needle (B) CCW to reduce WOT engine speed 10-30 RPM. Minimum WOT engine speed after adjusting should be over 7,150 RPM.

7. Stop and restart engine, and verify engine idle speed ranges from 2,800 to 3,200 RPM, and WOT engine speed is over 7,150 RPM. When final adjustment is completed, the engine should idle, accelerate smoothly, and attain WOT per above specification.

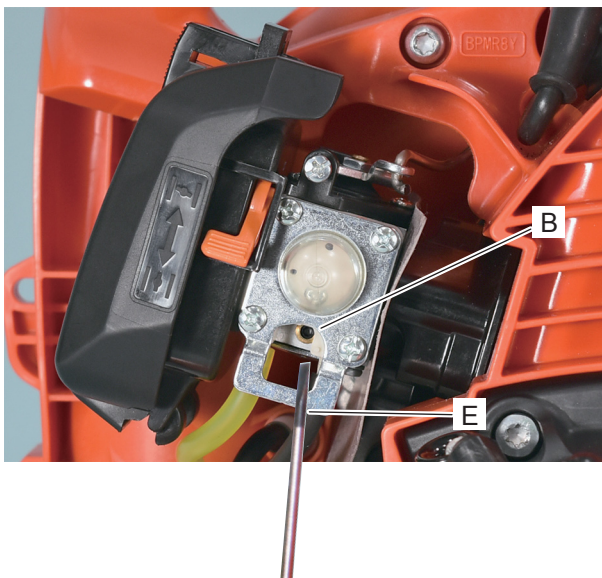

## 6-6-4 Inserting limiter plugs

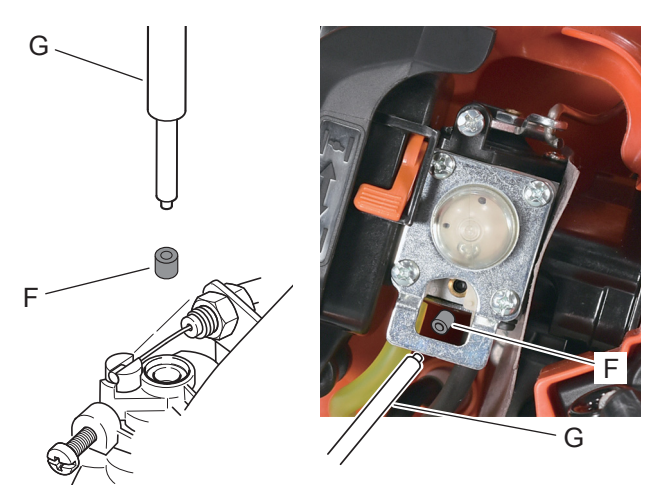

The diagram on the left shows a cross-section of the carburetor with a limiter plug (F) being inserted into a needle hole. A tool (G) is shown above the plug. The photograph on the right shows the carburetor in a red engine housing, with a limiter plug (F) being inserted into a needle hole using a tool (G).

After adjusting carburetor, insert and secure new plugs (F) P005-001270 deep in the needle holes per the Emission regulation using appropriate tool (G).

**NOTE :** Engine WOT, and idle speed in field operation may vary from final adjustment specifications due to changing ambient conditions, fuel, and engine loads. Safe engine RPM variances should be within the safe ranges for WOT and Idling speed as listed in Section 1-2, otherwise the carburetor should be readjusted.

**IMPORTANT:** The limiter plugs must be properly installed in L and H mixture needle holes to comply with Emission Regulations.



6-7 Testing carburetor

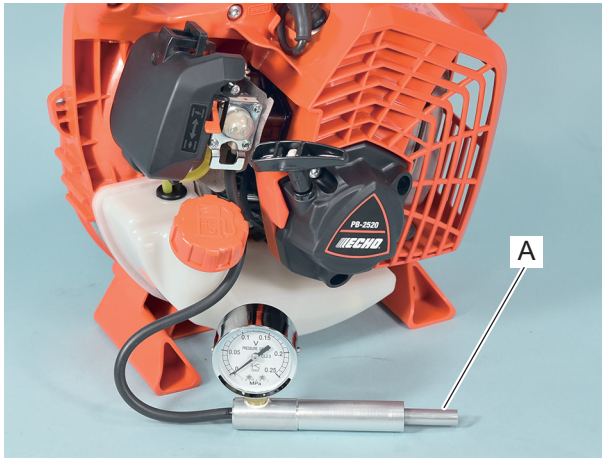

**NOTE:** To perform this test, carburetor interior should be wet with fuel. If dry, a little leakage may occur.

1. Remove air cleaner cover.
2. Disconnect black fuel line from carburetor and connect pressure tester 897803-30133 (A) to fuel inlet of carburetor.
3. Apply pressure approx. 100 kPa (1 kgf/cm<sup>2</sup>) (14 psi).
4. If pressure remains steady, follow step 5 and 6. If pressure drops, proceed to step 7.
5. Lightly push purge bulb once. Pressure tester reading should drop and remain above 50 kPa (0.5 kgf/cm<sup>2</sup>) (7 psi).
6. If reading does not drop, inspect inlet needle valve for sticking or metering lever height is too low.

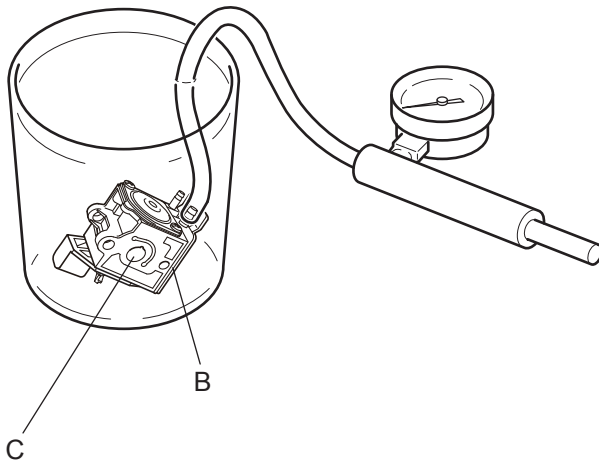

7. If pressure drops at step 3, or if pressure drops below standard figure at step 5, remove carburetor from the unit, disconnecting fuel return line and throttle rod.
8. Submerge carburetor in suitable clean solvent to locate the leak by applying pressure approx. 100 kPa (1 kgf/cm<sup>2</sup>) (14 psi).
9. If air bubbles come out between pump cover and carburetor body (B), inspect pump diaphragm, pump gasket, and diaphragm seat of carburetor body (Refer to "6-11 Inspecting diaphragm").
10. If air bubbles come out from throttle bore (C), inspect inlet valve, metering lever spring, and metering lever height (Refer to "6-10 Inspecting inlet needle valve").



## 6-8 Inspecting crankcase pulse passage

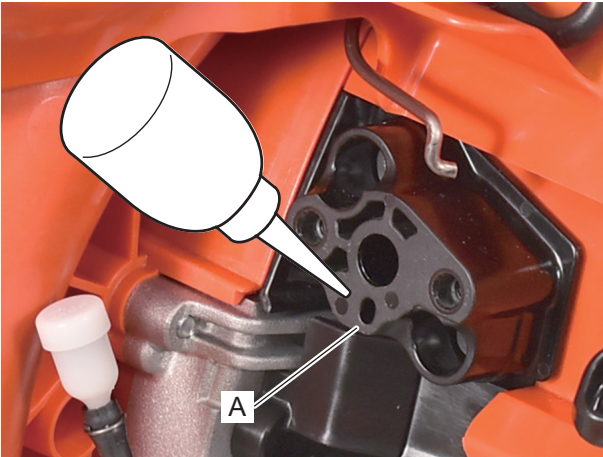

1. Drop a little oil in pulse hole (A) on intake insulator.
2. Remove spark plug and pull starter grip several times. Oil should spit back from the hole.
3. If not, inspect whether pulse passage is clogged. Repair or replace as required.

## 6-9 Inspecting metering lever height

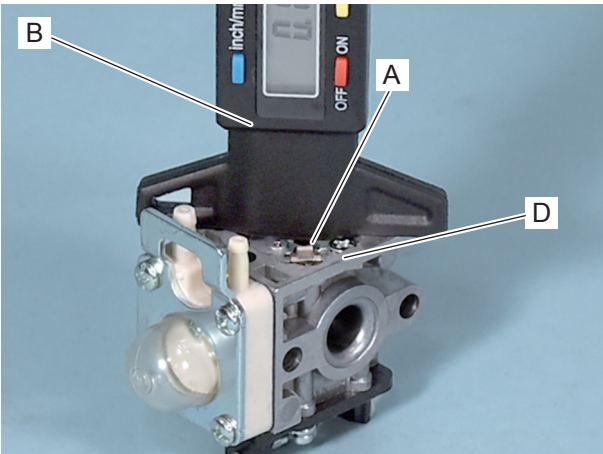

1. Remove carburetor.
2. Remove metering diaphragm cover, metering diaphragm and gasket.
3. Inspect metering lever (A) height by slide gauge (B).  
Metering lever height: 0.1-0.25 mm (0.004-0.010 in) lower than diaphragm seat (D)
4. If necessary, gently bend metering lever up or down to set metering lever to proper position.

**NOTE:** When metering lever is:

Too high → Fuel flooding occurs

Too low → Fuel starvation / overheating occurs

6-10 Inspecting inlet needle valve

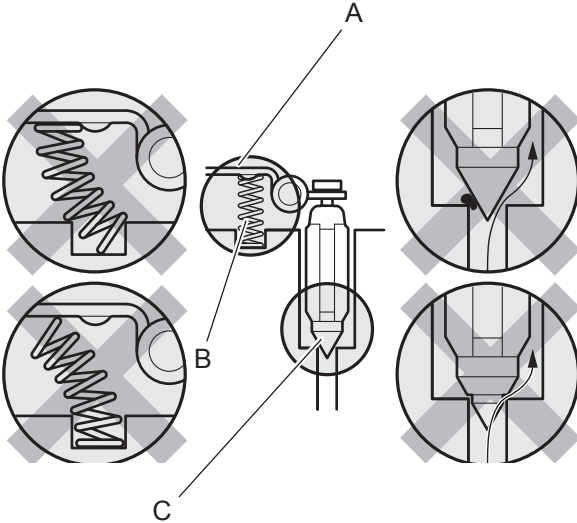

1. Remove metering lever (A) and pivot pin. Remove spring (B) and inlet needle valve (C).
2. Inspect inlet needle valve if worn or sticky. Clean or replace as required.

**NOTE:** Causes of fuel flooding from carburetor to cylinder are as follows:

- Improper assembling of metering lever and spring.
- Dirt between inlet needle valve and valve seat.
- Worn inlet needle valve tip.

3. Clean inlet needle valve seat using suitable clean solvent (do not use metal tools).
4. Reassemble inlet needle valve, spring, metering lever and pivot pin.

**NOTE:** Insure proper metering lever installation as follows.

- (1) Spring is seated in its hole at chamber floor.
- (2) Spring is under dimple of metering lever.
- (3) metering lever fork is holding inlet needle valve.

6-11 Inspecting diaphragm

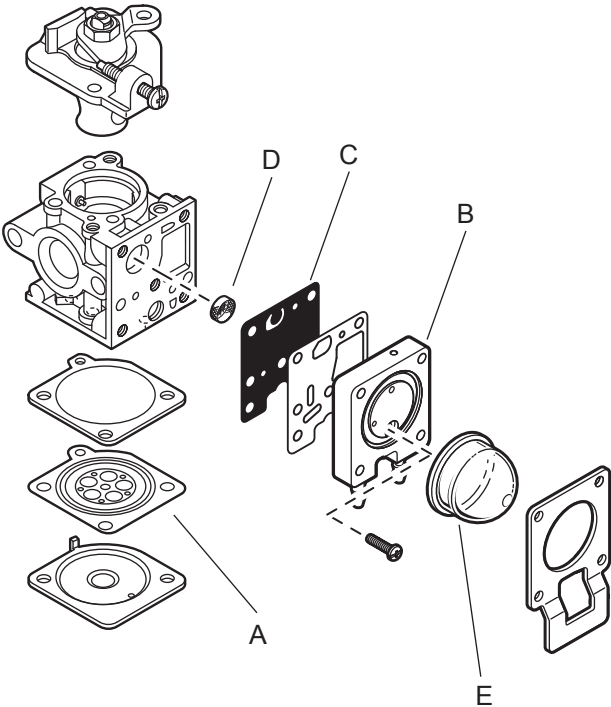

1. Check metering diaphragm (A) for hardening, distortion or pin hole. Replace it as required.
2. Remove pump body assembly (B) and pump diaphragm (C).
3. Check pump diaphragm and replace it if hardened or curled at the valve tabs.
4. Check metering and pump gaskets and replace if defective.
5. Check inlet screen (D) if blocked with dust. Remove and clean it or replace it if defective.
6. Check purge bulb (E) for crack, or fatigue. Replace it as required.

## 6-12 Installing carburetor

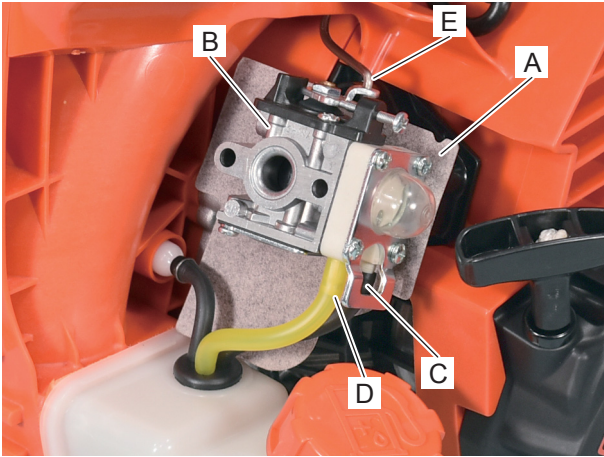

1. Set intake gasket (A) between intake insulator and carburetor (B).
2. Connect fuel line (C) to fuel inlet of carburetor (B). Connect fuel return line (D) to fuel outlet of carburetor(B).
3. Connect throttle rod (E) to carburetor (B).

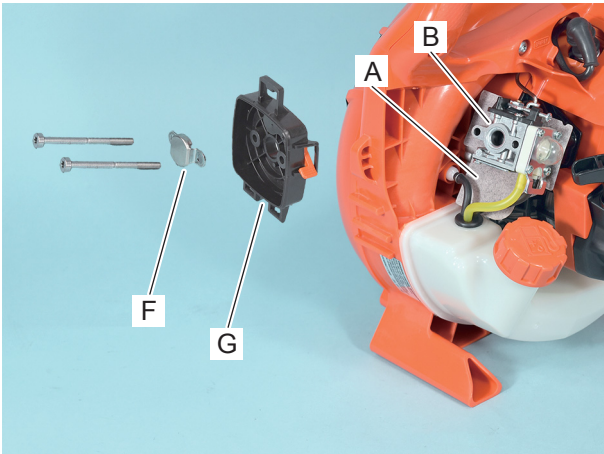

4. Assemble prevent plate (F), air cleaner case (G), carburetor (B) and intake gasket (A) to intake insulator .

7 ENGINE

- ( A ) Cylinder
- ( B ) Cylinder gasket
- ( C ) Piston ring
- ( D ) Piston
- ( E ) Snap ring
- ( F ) Needle bearing
- ( G ) Piston pin spacer
- ( H ) Crankcase
- ( J ) Oil seal
- ( K ) Dowel pin
- ( L ) Ball bearing
- ( M ) Crankshaft assembly
- ( N ) Piston pin
- ( P ) Crankcase gasket

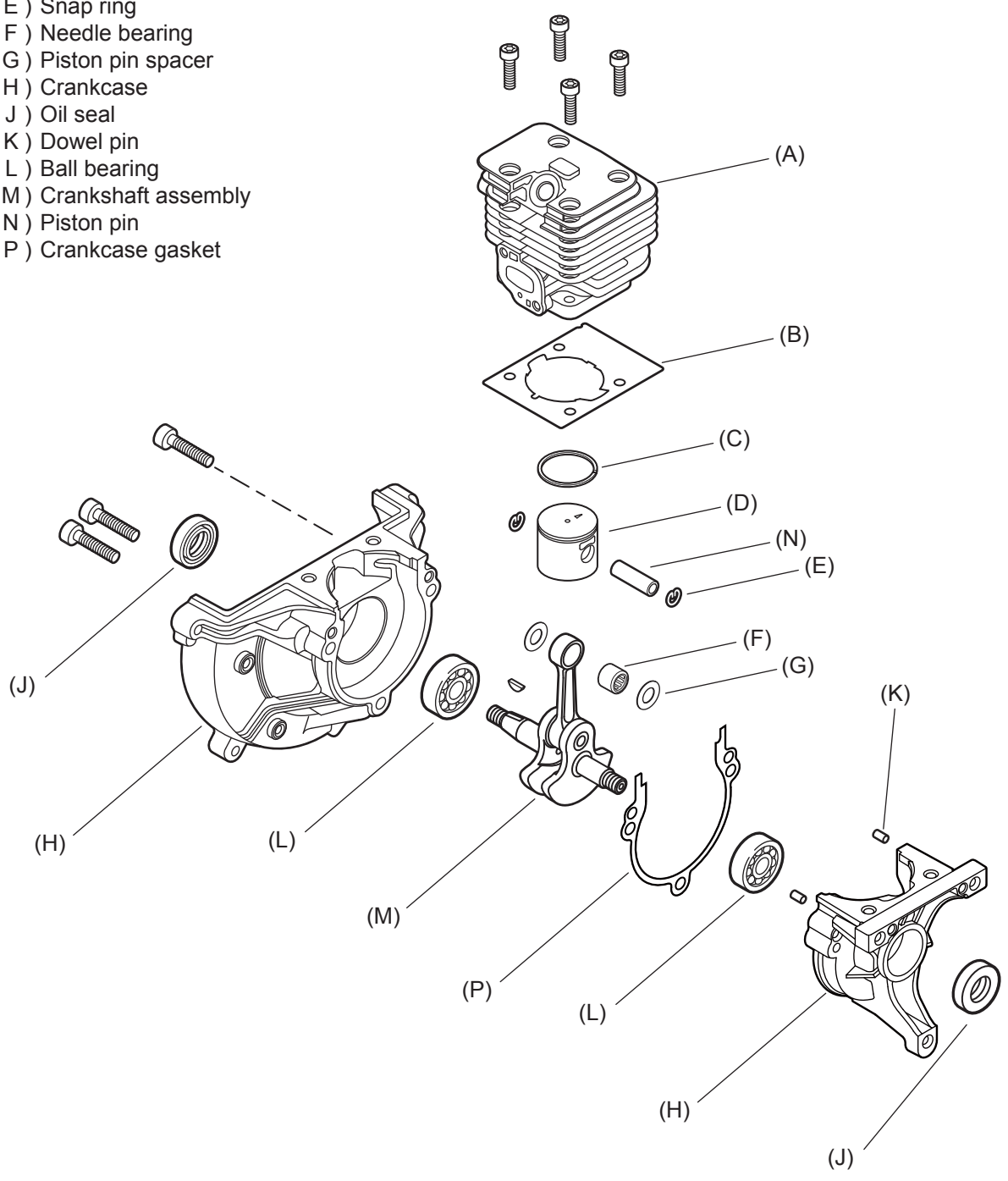



## 7-1 Testing cylinder compression

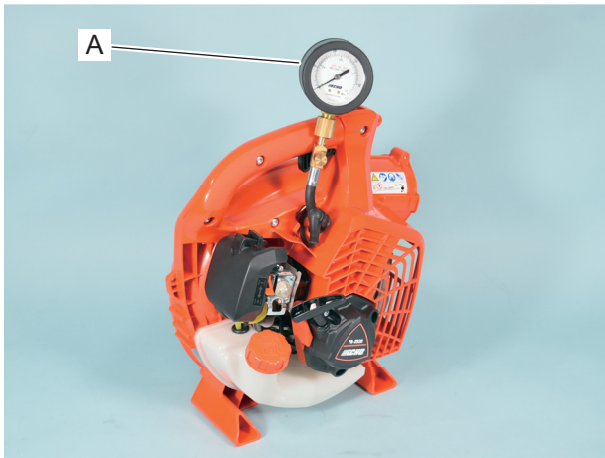

**NOTE:** Test cylinder compression when engine is cold.

1. Set ignition switch to STOP position and remove spark plug.
2. Install compression gauge 91037 (A) in spark plug hole and tighten by hand. Pull starter several times to stabilize reading on compression gauge.
3. If pressure is lower than approx. 75% of standard compression pressure (Refer to "1-2 Technical data"), inspect cylinder bore, piston and piston ring for wear or damage.

4. If pressure is more than approx. 125% of standard compression pressure, inspect cylinder combustion chamber and exhaust port, piston crown, and muffler for carbon deposits.

**NOTE:** Compression pressure varies with volume of compression gauge tip occupying cylinder combustion chamber. If gauge tip volume is considerably different from spark plug volume, it is recommended to measure and note compression pressure of brand-new engines as standard pressure in advance.

## 7-2 Cleaning cooling air passages

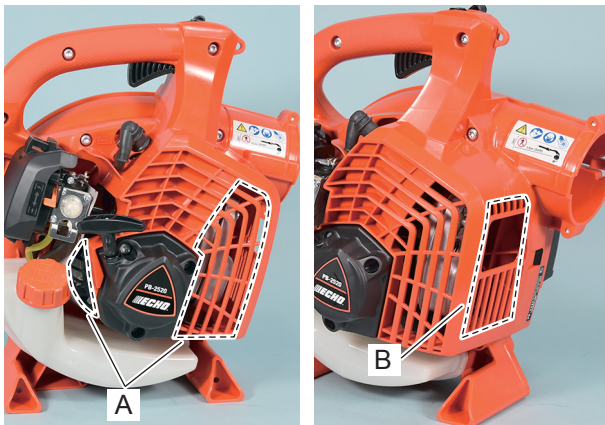

**NOTE:** To maintain proper engine operating temperatures, cooling air must pass freely through the cylinder fin area. This flow of air carries combustion heat away from the engine.

1. Clean accumulated debris from crankcase intake grill (A) and discharge grill (B) with brush or compressed air as required.

**WARNING**  **DANGER**

**Always wear eye protection when using compressed air for cleaning. Otherwise, eye damage can occur from flying particles.**

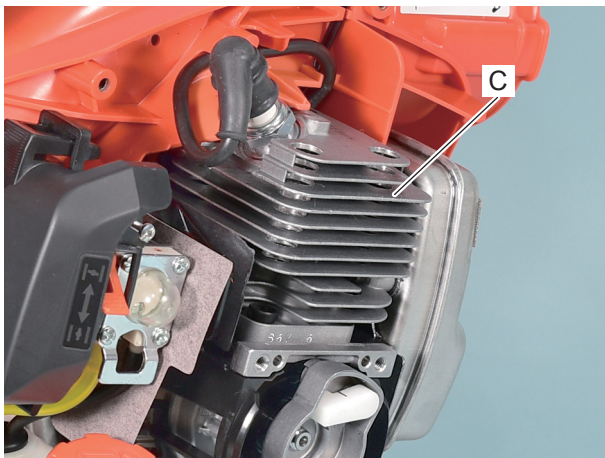

2. Remove engine cover if cylinder fins (C) are hard to clean. Clean the clearance of cylinder fins using wooden stick, plastic stick or compressed air.

**NOTE:** To prevent debris from entering cylinder, reinstall spark plug, carburetor, and air filter before cleaning cylinder fins.



7-3 Inspecting muffler and exhaust port

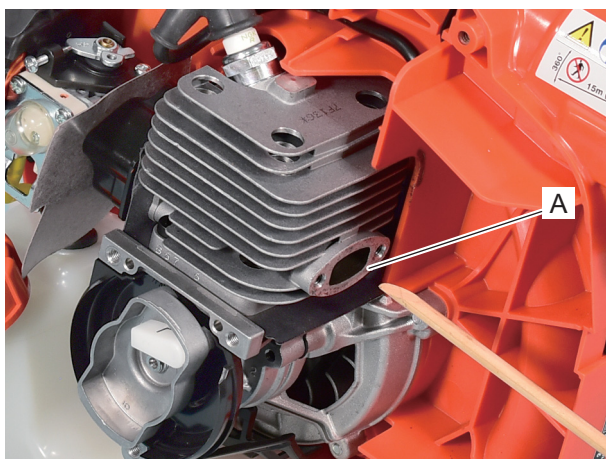

1. Remove muffler.
2. Inspect cylinder exhaust port (A) and clean the port (A) using wooden or plastic stick if carbon is found.

**NOTE:** When cleaning exhaust port, always position piston at Top Dead Center (TDC) to prevent carbon from entering cylinder. Do not use metal tool, and be careful not to scratch piston or cylinder.

**NOTE:** Replace muffler gasket with new one when removing muffler.

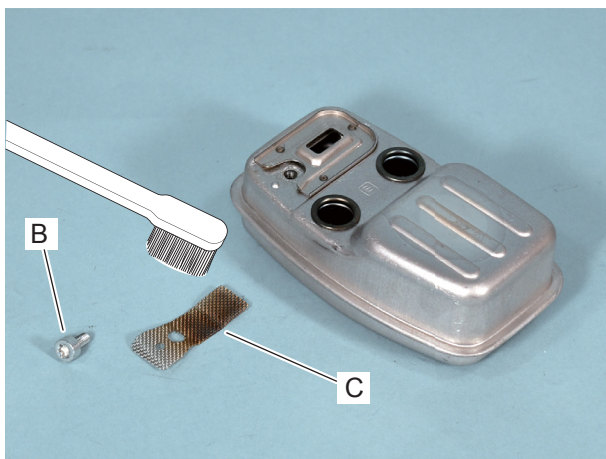

3. Remove bolt (B) and spark arrestor screen (C) from muffler.
4. Remove carbon deposits from spark arrestor screen (C). If screen has heavy deposits, replace with new one.
5. Reassemble spark arrestor screen (C) and tighten bolt (B).
6. Reinstall muffler with new muffler gasket.

## 7-4 Testing crankcase and cylinder sealings

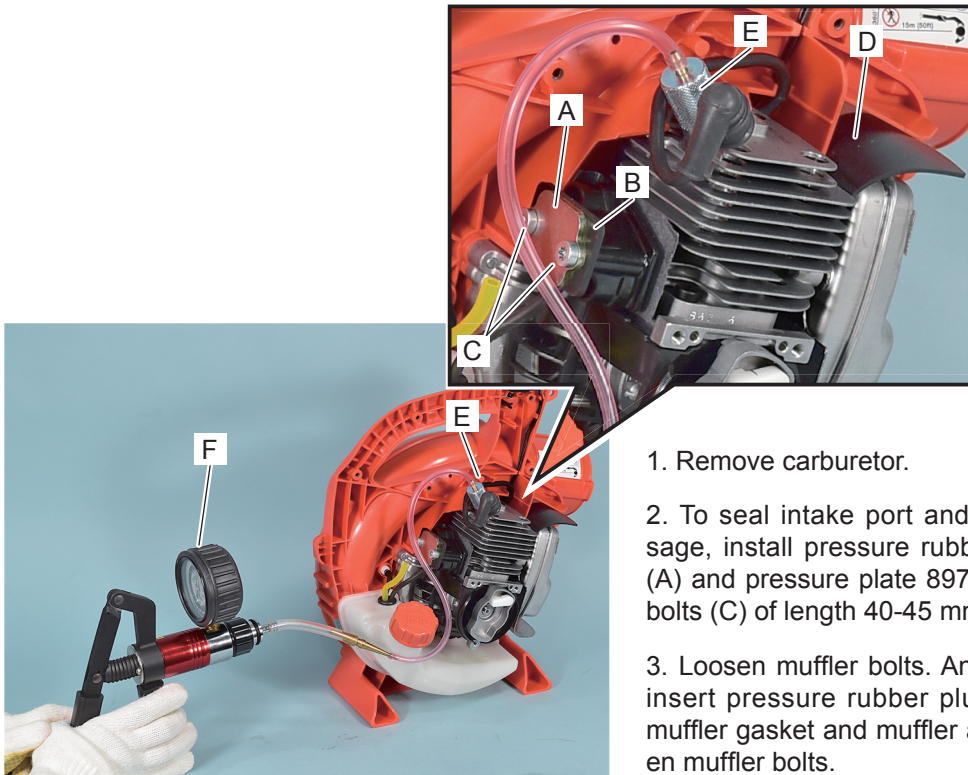

1. Remove carburetor.
2. To seal intake port and crankcase pulse passage, install pressure rubber plug 897826-16131 (A) and pressure plate 897827-16131 (B) with M5 bolts (C) of length 40-45 mm (1.6-1.8 in).
3. Loosen muffler bolts. And to seal exhaust port, insert pressure rubber plug 91041 (D) between muffler gasket and muffler as shown. Then retighten muffler bolts.
4. Remove spark plug and install pressure connector A131-000150 (E) to spark plug hole.
5. Connect pressure tester 91139 (F) to pressure connector (E).
6. Apply pressure approx. 50 kPa (0.5 kgf/cm<sup>2</sup>) (7.3 psi) by pressure tester and leave for 30 seconds.
7. If the reading drops, leakage may occur.
8. Leakage may occur from crankcase seam or oil seal. Use soapy water to locate leakage.
9. Then, apply negative pressure approx. 30 kPa (0.3 kgf/cm<sup>2</sup>) (4.4 psi) by pressure tester and leave for 30 seconds.
10. If the reading drops, leakage may occur from oil seal. Inspect oil seal for damage or wear.
11. Remove pressure tester (F) and pressure connector (E). Remove pressure rubber plug (A) and rubber trapezoid (D).

### 7-5 Replacing oil seal

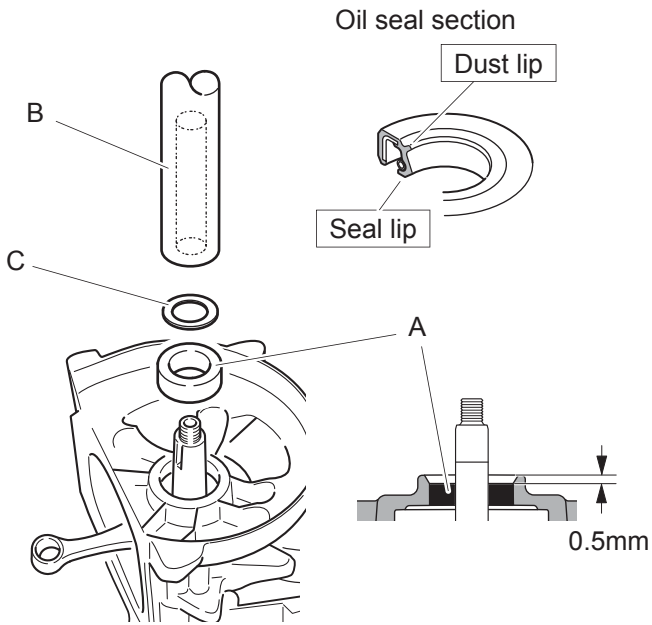

1. Pry defective oil seal from engine.

**NOTE:** Be careful not to damage housing of oil seal in crankcase.

2. Apply grease on dust lip and seal lip of new oil seal (A) to avoid damage of lips while inserting crankshaft into oil seal.
3. Lubricate circumferences of oil seal with thinner.
4. Push oil seal (A) by maximum 0.5 mm (0.02 in.) deep using oil seal tool 897726-21430 (B) with washer 10001-418430 (C) (size : inner dia.12.2 x outer dia.20 x 0.5mm thickness).

### 7-6 Inspecting cylinder

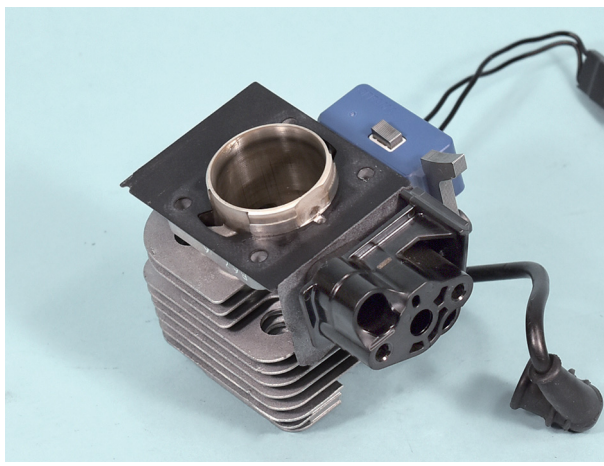

1. Remove cylinder from engine.

**NOTE:** When removing cylinder solely for the purpose of inspecting cylinder, leave ignition module, and intake insulator to avoid extra work.

**NOTE:** Gently tap cylinder with plastic mallet at carburetor and/or muffler sides of the cylinder head if it is difficult to remove.

2. Inspect cylinder combustion chamber and clean with a plastic or wooden scraper if carbon is found.

**NOTE:** Do not use metal tools, or damage to cylinder wall may result.

3. Inspect cylinder wall and replace with new one if plating is worn, peeled away, scored or exposing cylinder base metal.

## 7-7 Inspecting piston and piston ring

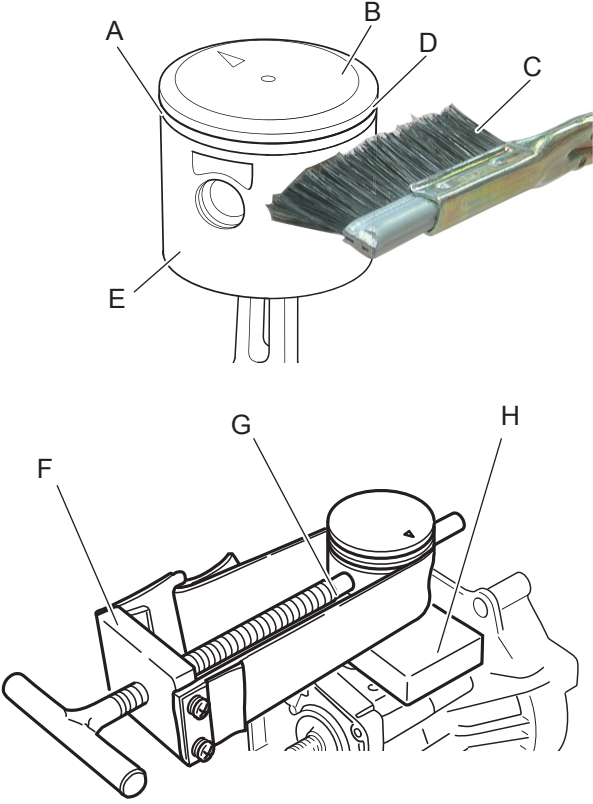

1. Inspect piston ring (A) and replace it if broken, scored, or exceeded service limits (Refer to "1-5 Service limits").
2. Inspect piston crown (B). Clean with fine sand paper, oil stone, and soft cleaning brush (C) if carbon is found.
3. Inspect top land (D), ring groove and skirt (E). Clean them with soft cleaning brush (C), if carbon is found.

**NOTE:** Do not use square end of broken piston ring when cleaning piston ring groove, otherwise piston ring groove might be damaged.

4. Remove snap rings from both sides of piston pin.
5. Push piston pin out from piston.

**NOTE:** If piston pin is tight, use piston pin tool 897702-30131 (F) with adapter (G) stamped "8" on an end and piston holder 897719-02830 (H).

6. Inspect needle bearing and washers, and replace if wear or discoloration is noted.

## 7-8 Disassembling crankcase

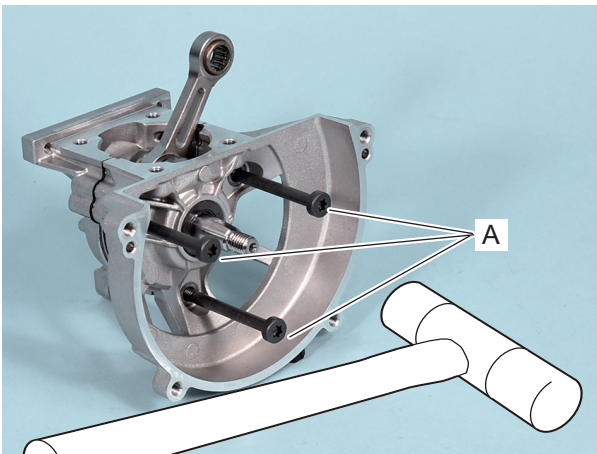

1. Remove cylinder, gasket and piston.
2. Remove woodruff key from crankshaft flywheel end.
3. Remove three crankcase bolts.
4. Screw M5 bolts (A) of length 65-75 mm (2.5 -3.0 in) to crankcase as shown.
5. Hold crankcase and alternately tap three bolts (A) using plastic mallet to separate crankcase halves.
6. Clean inside of crankcase halves if dirty. Replace as a set if damaged.
7. Inspect crankshaft for roughness (crankshaft runout), discoloration, or other damage. Replace it with new one as required.



7-9 Replacing ball bearing

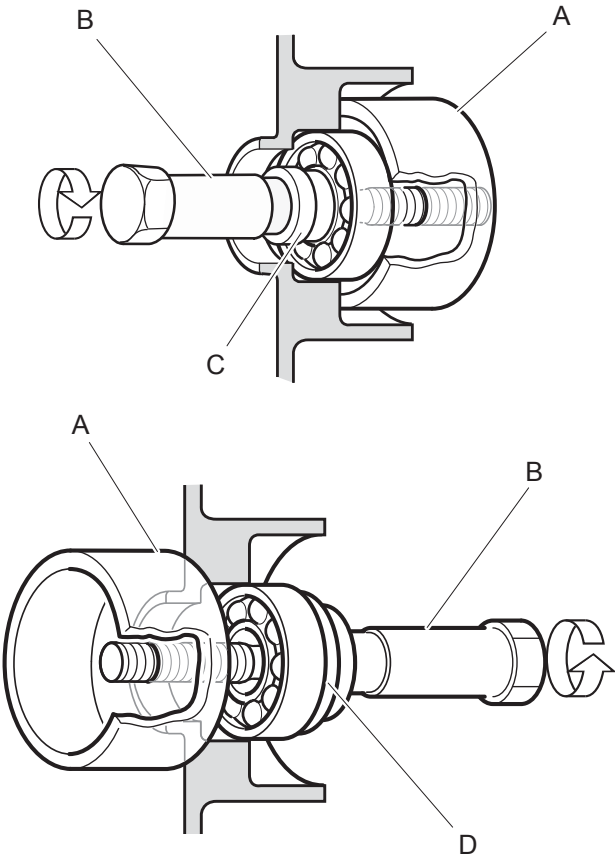

1. Check main ball bearing for smooth rotation, after disassembling crankshaft. If rough, replace it (them) with new one.

2. Pry oil seal from crankcase.

3. Remove main ball bearing from crankcase half using bearing tool 897701-14732 as follows.

4. Set boss (A) and shaft (B) with adapter (C) (inner dia. 12 mm, outer dia. 19 mm) as shown.

5. Tighten shaft (B) with wrench to remove ball bearing.

6. Coat bearing housing in crankcase with a lithium grease.

7. Set ball bearing with boss (A), shaft (B) and adapter (D) (inner dia. 12 mm, outer dia. 27.5 mm) as shown.

8. Tighten shaft (B) with wrench to press ball bearing into the crankcase half.

**NOTE:** Preheat around bearing housing of crankcase using a floodlight or a suitable heater for easier assembly.

9. Check that bearing is seated to the bottom and rotates smoothly. Install new oil seal.

## 7-10 Assembling crankshaft and crankcase

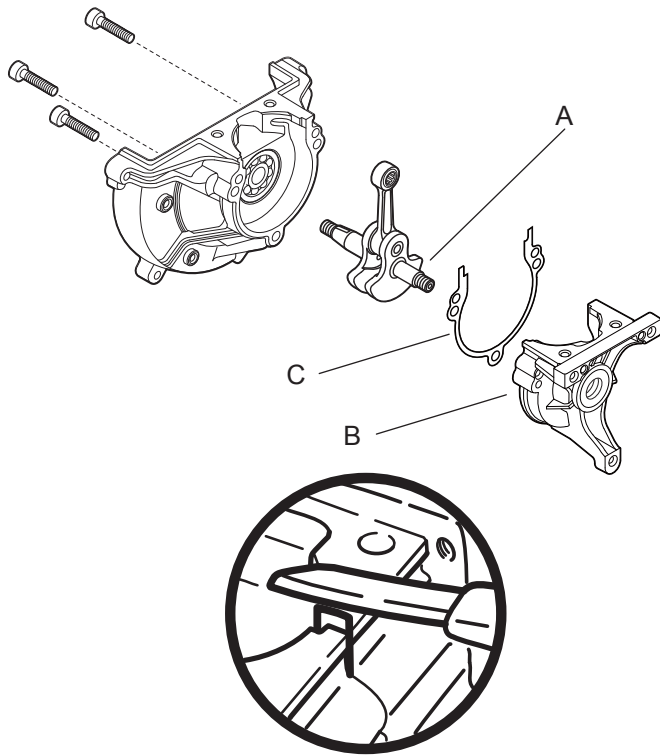

1. Clean mating surface of each crankcase half.
2. Heat ball bearing for easier installation. Then insert crankshaft starter end (A) into starter side crankcase half (B) until properly seated.

**WARNING**  **DANGER**

When using a heat gun, wear gloves. Otherwise, a burn will result.

3. Place new crankcase gasket (C) on starter side crankcase half (B).
  4. Reassemble both crankcase halves together ensuring that dowel pins on crankcase half are properly seated in holes of the opposite crankcase half.
  5. Tighten three bolts to secure crankcase halves together and check crankshaft for smooth rotation.
- NOTE:** If crankshaft doesn't rotate smoothly, tap both ends of crankshaft with plastic mallet several times. And recheck crankshaft for smooth rotation.
6. Carefully remove excess portion of crankcase gasket (C) with sharp knife.

## 7-11 Installing piston

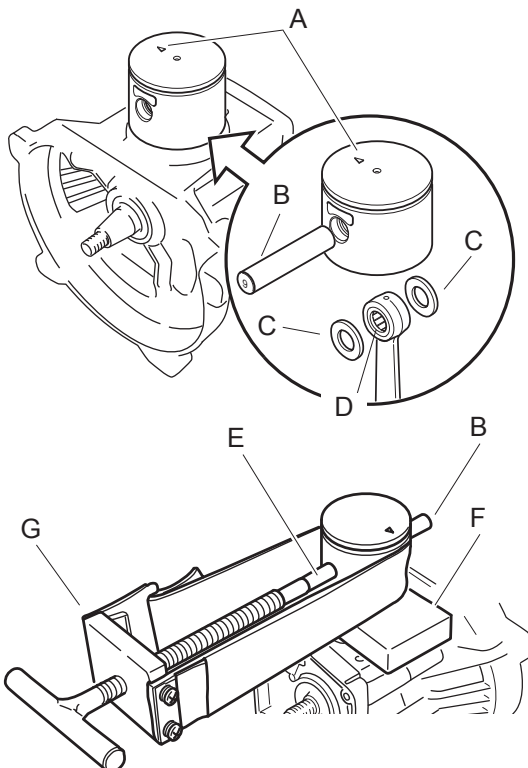

1. Place piston over the small end of connecting rod, so that the arrow mark (A) on piston points toward muffler.
2. Insert piston pin guide (B) stamped "9", through piston, washers (C) and needle bearing (D) in connecting rod as shown.

3. Insert piston pin (E) in piston pushing out piston pin guide (B) using piston pin tool 897702-30131 (G) and piston holder 897719-02830 (F).
4. Install new snap rings to the piston pin bore, and be sure that they are correctly seated in the grooves.

7-12 Installing piston ring and cylinder

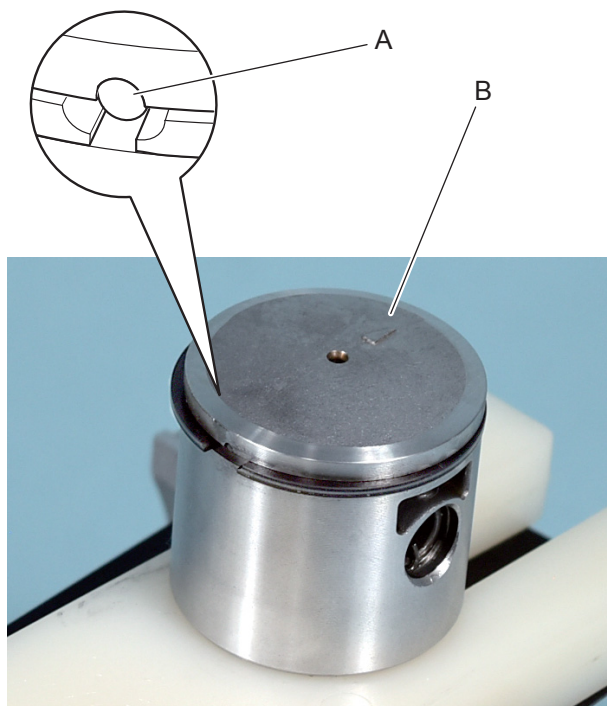

1. Install piston ring on piston ensuring that locating pin (A) is positioned between ring ends.

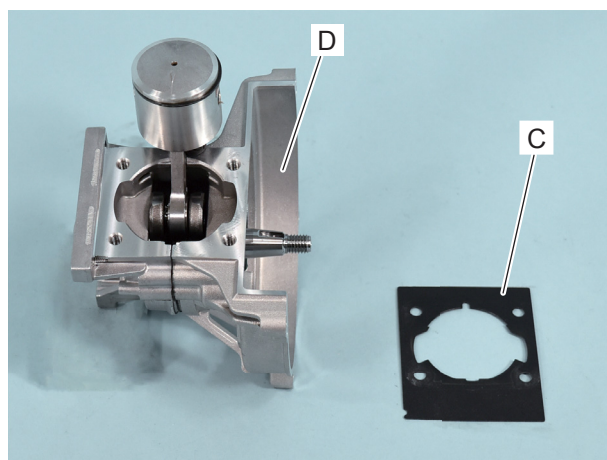

2. Set new cylinder gasket (C) on crankcase (D).

**NOTE:** When setting cylinder gasket (C), it is convenient to apply Loctite #222, ThreeBond 1324 or equivalent on several spots of the bottom of cylinder gasket (C) to fix it on crankcase temporarily.

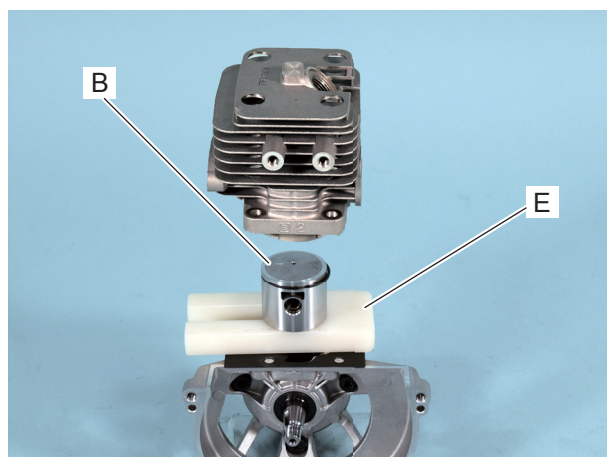

3. Apply oil to piston ring and cylinder internal wall.

4. Install cylinder over piston ensuring that exhaust side of cylinder is at arrow side (B) of piston.

**NOTE:** When installing piston, it is convenient to use piston holder 897719-02830 (E) for stabilizing piston.

**NOTE:** Do not twist cylinder while installing, otherwise, piston ring and/or cylinder wall may be damaged.

**7-13 Assembling engine assembly and other parts**

Assemble engine assembly and other parts, referring to the following instructions.

1. Assembling flywheel and woodruff key: "4-11 Replacing flywheel and key"
2. Assembling engine assembly, control system and switches: "4-5 Inspecting ignition module", "4-6 Replacing ignition module", "4-8 Inspecting ignition switch", "4-9 Replacing ignition switch" "5-1 Disassembling and assembling handle and control parts".
3. Assembling fuel tank and lines: "6-3 Inspecting fuel tank and line", "6-5 Replacing fuel line, fuel return line, tank vent line and grommet"
4. Assembling fan and fan case: "3-3 Assembling fan and fan case".
5. Assembling starter pawl: "2-5 Replacing starter pawl".



8 MAINTENANCE GUIDE

8-1 Disassembly chart

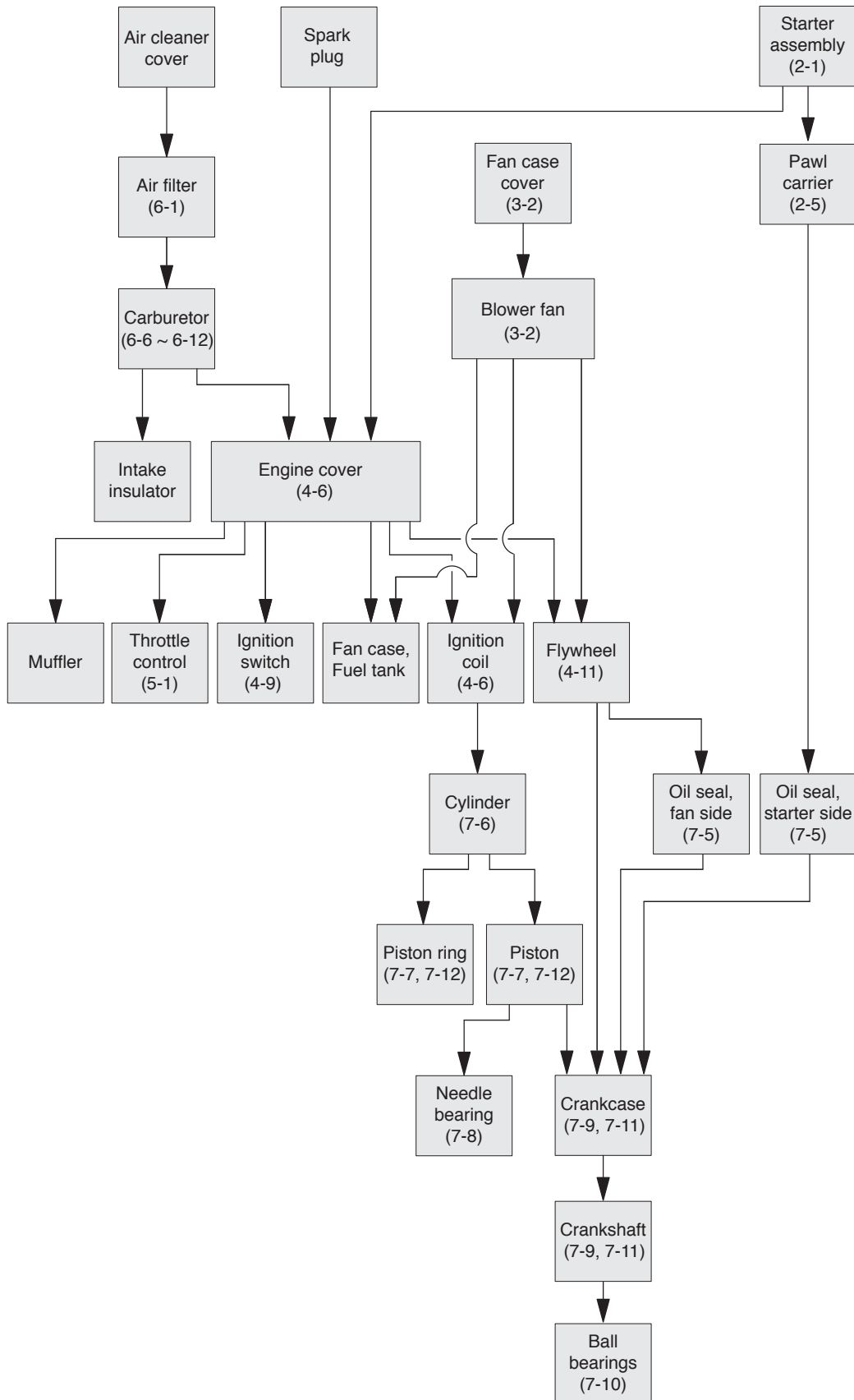



















































































































### 8-2 Troubleshooting guide

TROUBLE	
Engine does not crank.	01
Engine does not start.	02
Fuel leaks.	03
Idling is not stable.	04
Acceleration is poor.	05
Engine stalls at high speed.	06
Engine lacks power.	07
Engine overheats.	08
Engine misfires.	09
Engine/others are extremely noisy.	10
Fuel consumption is excessive.	11
Vibration is excessive.	12
Engine does not stop.	13

INSPECTING	REFERENCES	Inspecting ☉ first.												
		13	12	11	10	09	08	07	06	05	04	03	02	01
<b>Starter system</b>														
Rewind spring	2-3													○
Starter pawl / spring	2-5													☉
<b>Ignition system</b>														
Sparks	4-2					☉			○	○	○		☉	
Spark plug	4-3					○	○		○	○	○		○	
Spark plug cap / coil	4-4					○							○	
Ignition switch	4-8	☉				○							○	
Ignition coil	4-5					○			○	○	○		○	
Pole shoe air gaps	4-7					○	○				○		○	○
Flywheel	4-10		○			○					○		○	
Flywheel key	4-11					○	○	○		○	○		○	

8-2 Troubleshooting guide (continued)

INSPECTING	REFERENCES	Inspecting  first.												
		13	12	11	10	09	08	07	06	05	04	03	02	01
<b>Fuel system / Carburetor</b>														
Air filter	6-1													
Fuel cap / strainer	6-2													
Fuel tank / vent / line	6-3 to 6-5													
Carburetor adjustment	6-6													
Carburetor leakage	6-7													
Crankcase pulse passage	6-8													
Carburetor metering lever	6-9													
Carburetor inlet valve	6-10													
Carburetor diaphragm	6-11													
Carburetor Welch plug	6-12													
Throttle lever	5-1													
Fuel	1-1													
Oil	1-1													
<b>Engine</b>		<b>13</b>	<b>12</b>	<b>11</b>	<b>10</b>	<b>09</b>	<b>08</b>	<b>07</b>	<b>06</b>	<b>05</b>	<b>04</b>	<b>03</b>	<b>02</b>	<b>01</b>
Cylinder compression	1-2, 7-1													
Cooling air passage	7-2													
Muffler / Exhaust port	7-3													
Crankcase / cylinder sealings	7-4													
Cylinder	7-6													
Piston / Piston ring	7-7													
Crankshaft	7-9													
Oil seal / Ball bearing	7-5, 7-10													
<b>Blower</b>		<b>13</b>	<b>12</b>	<b>11</b>	<b>10</b>	<b>09</b>	<b>08</b>	<b>07</b>	<b>06</b>	<b>05</b>	<b>04</b>	<b>03</b>	<b>02</b>	<b>01</b>
Fan	3-1, 3-2													
Fan case	3-1, 3-2													

## 8-3 Service intervals

Inspecting point	Service	Reference	Intervals		
			Daily or Before use	3 months or 100 hours	6 months or 300 hours
Screws and bolts *	Retighten / Replace		○		
Air filter	Inspect / Clean	6-1	○		
Choke system	Inspect / Clean		○		
Carburetor	Inspect / Repair	6-6 to 6-13			○
Fuel leaks	Inspect / Repair	6-2 to 6-5	○**		
Fuel line and grommet	Inspect / Repair	6-3, 6-5	○		
Fuel strainer	Clean / Replace	6-2		○	
Fuel tank	Clean inside	6-3, 6-4		○	
Spark plug	Clean / Regap	4-3		○	
	Inspect / Replace	4-2, 4-3			○
Muffler Spark Arrestor	Inspect / Clean / Replace	7-3		○	
Muffler and exhaust port	Inspect / Clean	7-3	○		
Throttle connecting rod	Grease	5-1		○	
Leads and connections	Inspect / Repair	4-8, 4-9		○	
Starter system	Inspect / Repair	2-1 to 2-5	○		

**Daily:** Inspecting in every services.

**IMPORTANT:** Service intervals shown above are maximum. Actual use and your experience will determine the frequency of required maintenance.

\* Retighten the following screws and bolts after first 1 week use, and every 3 months.

Starter assembly bolts (3 pcs.)

Muffler bolts (2 pcs.)

\*\* Inspect after every refuel.





**ECHO**®

**shindaiwa**®

**YAMABIKO**

Published by  
YAMABIKO Corp.  
Tokyo Japan

1804