



# Workshop manual

Park Pro  
2015

**STIGA**

Edition	Manual	Chapter	Page
2014-12-09	Workshop Manual, GGP Park	1 General instructions	1

# 1 General instructions

## Contents in this chapter

<b>1.1 Introduction.....2</b>	1.2.9 Inspection ..... 3
1.1.1 Responsibility declaration.....2	<b>1.3 Unpacking and assembly ..... 4</b>
1.1.2 How this manual is used .....2	1.3.1 General ..... 4
1.1.3 Abbreviations.....2	1.3.2 Tyres..... 4
<b>1.2 Safety Precautions .....2</b>	1.3.3 Battery ..... 5
1.2.1 Symbols and general warnings.....3	1.3.4 Final checks..... 6
1.2.2 Warm parts.....3	<b>1.4 Service ..... 7</b>
1.2.3 Moving parts.....3	1.4.1 Service times ..... 7
1.2.4 Lifting and blocking up.....3	1.4.2 First Service..... 8
1.2.5 Cleanliness.....3	1.4.3 Basic service..... 9
1.2.6 Tightening torque .....3	<b>1.5 Oil and filter ..... 13</b>
1.2.7 Sharp edges .....3	<b>1.6 Technical specifications ..... 13</b>
1.2.8 Replacement parts .....3	<b>1.7 General tightening torque ..... 13</b>
	<b>1.8 Instructions for use ..... 13</b>

## General

This Workshop Manual is intended for GGP Park model 2015 professional high.

This Manual do not cover repair instructions for the engines. Regarding engines, contact the respective representative in the actual country.

This Manual and its specifications are valid for machines in their original design. In case of modified or changed machine, i.e. the engine is replaced, the manual accordance is limited.

The manual is divided in the following chapters:

**Chapter 1 is this chapter**

**Chapter 2 Chassis**

**Chapter 3 Steering**

**Chapter 4 Hydraulic system**

**Chapter 5 Belts**

**Chapter 6 Control Wires**

**Chapter 7 Electrical system**

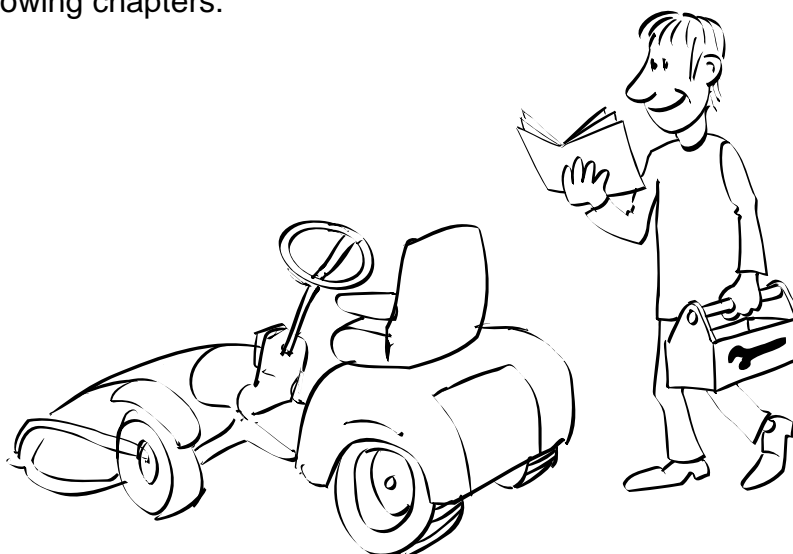



Edition	Manual	Chapter	Page
2014-12-09	Workshop Manual, GGP Park	1 General instructions	3

### 1.2.1 Symbols and general warnings



#### Warning!

**This symbol indicates a risk of personal injury or damage if the instructions are not followed.**



#### Note!

This text indicates a risk of damage to the material or risk of unnecessarily complicated work if the instructions are not followed.

### 1.2.2 Warm parts

Please observe that engine and exhaust system picks up a lot of heat during use. To avoid injuries, allow the machine to cool before any kind of repairs are made to or near parts of the engine or exhaust system.

### 1.2.3 Moving parts

The machines are all equipped with v-belt transmissions. Always stop the engine and remove the starter key before inspections or repairs are carried out.

Always use extreme caution when testing systems with moving parts to avoid injuries.

Always use Genuine Spare Parts during service work.

### 1.2.4 Lifting and blocking up

Before work under the machine, always make sure that lifting devices and jack-stands are approved for the weight. Work safe!

### 1.2.5 Cleanliness

Clean the machine before starting repairs. Dirt that penetrates into sensitive components can seriously influence the service life of the machine.

### 1.2.6 Tightening torque

Unless otherwise stated the tightening torque in the tables in the section Technical specifications must be used for the different sizes of screws. This does not refer to self-tapping screws, which are mainly used for the assembly of body parts.

### 1.2.7 Sharp edges

Watch out for sharp edges, especially when working with the mower deck. The blades can be very sharp. Always wear gloves when working with the blades.

### 1.2.8 Replacement parts

Always use Genuine Spare Parts during service work.

### 1.2.9 Inspection

Each part dismantled in conjunction with service work must be inspected. Examine for: wear, cracks, out of roundness, straightness, dents, discolouring, abnormal noise and jamming.

Edition	Manual	Chapter	Page
2014-12-09	Workshop Manual, GGP Park	1 General instructions	4

## 1.3 Unpacking and assembly

### 1.3.1 General

Every GGP Park has undergone an extensive control programme before delivery. The machines are delivered as completely assembled as possible.

Thanks to this the assembly on delivery is rapid and easy.

The correct and careful assembly of the machine on delivery is a simple way of ensuring satisfied customers!

A complete assembly instruction is given in the owners manual delivered with the machine. This section will give complement information and explanations for the assembly.



Note!

The machine shall remain placed on the pallet during the unpacking and assembly.

### 1.3.2 Tyres

1. Check the air pressure in the tyres. The pressure is designated on the floor mat. The air pressure in the tyres is of critical importance for the performance and handling of the machine. The correct air pressure for mowing is 0.6 bar (9 psi) in the front tyres, and 0.4 bar (6 psi) in the rear tyres.

When using heavy accessories, e.g. snow thrower, it may be necessary to increase the pressure somewhat. However, the maximum permitted pressure is always 0.8 bar (12 psi).

Too high pressure in the tyres leads to that the machine drives poor due to:

- A small surface in contact to the ground.
- Hard tyre = less flexibility = self cleaning characteristic deteriorate.

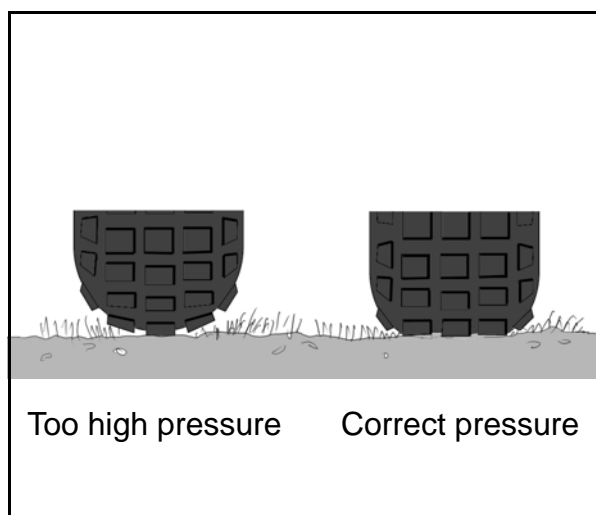

Edition	Manual	Chapter	Page
2014-12-09	Workshop Manual, GGP Park	1 General instructions	5

### 1.3.3 Battery

The battery is a valve regulated battery.

Load and assemble the battery, following the instructions below.

The battery needs limited maintenance. It has no electrolyte levels or plugs.

**Warning!**  
 **Do not wear rings, metallic bracelet, chain round the neck or similar metal objects when working with the battery. It can cause short-circuit, burns and fire.**

**Warning!**  
 **The battery must be fully charged before being used for the first time. The battery must always be stored fully charged. If the battery is stored while discharged, serious damage will occur.**

#### Charging with the engine

The battery can be charged using the engine's generator as follows:

1. Install the battery in the machine as shown below.
2. Place the machine outdoors or install an extraction device for the exhaust fumes.
3. Start the engine according to the instructions in the user guide.
4. Allow the engine to run continuously for 45 minutes.
5. Stop the engine. The battery will now be fully charged.

#### Storage

The battery voltage is not allowed to drop under 12,5 V during storage.

Make sure that the battery voltage always is more than 12,5 during storage. If not, the battery will be destroyed.

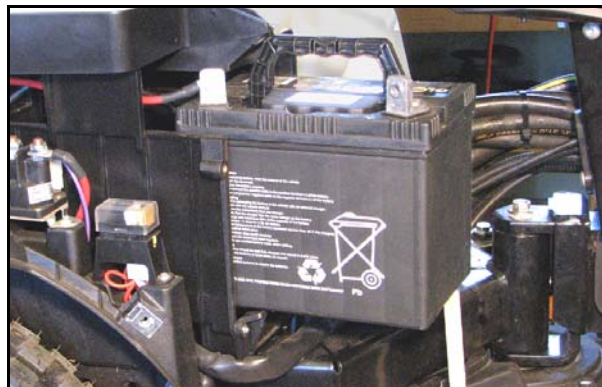

**Warning!**  
 **If the cables are disconnected/connected in the wrong order, there is a risk of a short-circuit and damage to the battery.**

**Warning!**  
 **If the cables are interchanged, the generator and the battery will be damaged.**

**Warning!**  
 **The engine must never be driven with the battery disconnected. There is a risk of serious damage to the generator and the electrical system.**

#### Charging using battery charger

When charging using a battery charger, a battery charger with constant voltage must be used.

Ordering number: 1136-0602-01.

The battery can be damaged if a standard type battery charger is used.

Edition	Manual	Chapter	Page
2014-12-09	Workshop Manual, GGP Park	1 General instructions	6

### 1.3.4 Final checks

#### Removing from pallet

All the above measures shall have been done with the machine standing on the pallet. Now, loosen the remaining straps and roll off the machine from the pallet. Fit and adjust accessories.

#### Test driving



#### Warning!

**Do not drive without a work equipment (mower deck) attached. Risk for turning over.**

Drive the machine for a few minutes. Test all the functions. Pay special attention to the safety functions. If the machine is to be delivered with mower deck or other accessories, fit these before test driving the machine.

#### HST oil

Check the oil level in the HST's expansion tank after test driving, and top up if necessary.

#### Engine oil

Check the oil level in the engine and top up if necessary.

#### Miscellaneous

Give the machine a general inspection.

- Is the machine clean?
- Is there any oil leakage?
- Abnormal noise or rattle?

#### Receipt

By filling in the guarantee certificate you guarantee that the delivery service has been correctly conducted.

Remember to make sure that the customer receives all the documentation when the machine is collected / delivered.

Edition	Manual	Chapter	Page
2014-12-09	Workshop Manual, GGP Park	1 General instructions	7

## 1.4 Service

Every new machine is delivered with a service book. This service book is part of the active post-market programme and shall be kept in a safe place during the entire lifetime of the machine. Hand over the service book if the machine is sold in 2:nd hand.

Service should generally be carried out at least every 50 operating hours (exception of the first service), although in accordance with the conditions below.

There are three different grades of service events. Every service event consists of a number of service points as described in the following paragraphs. Every service point has a number which refer to a describing text after the schedules.

The grades of service events are:

- First service
- Intermediate service
- Basic service

Some service points do not coincide with the scheduled service intervals, but shall be performed in connection with a scheduled service when possible. E.g. some items shall be performed at every second service and some also between two services. These service points are described with procedure and interval in the respective "Instruction for use".

Typical service points wich not coincide with scheduled service intervals are:

- Cleaning/changing air filter in some engines.
- Change of oil in some engines.
- Valve adjustments for some engines.
- Change of transmission oil.
- Change of spark plug in some engines.

### 1.4.1 Service times

Service	Shall be performed
First service	Within 5 hours of running
Intermediate service	After the first 50 hours of running and then 50 hours after/before every basic service.
Basic service	Every 100 hours or every year, which first occur.



Edition	Manual	Chapter	Page
2014-12-09	Workshop Manual, GGP Park	1 General instructions	8

### 1.4.2 First Service

This service is very important to safeguard the continuing function of the machine.

The first service includes the service points as per the table below.

Number	Service point
1	Safety check.
2	Tyres, air pressure.
3	Engine oil and filter, see "Oil and filter" at page 13.
4	Oil level in HST, see "Oil and filter" at page 13.
5	Belt transmissions, check.
6	Battery check.
19	Test driving.

### 1.5.2 Intermediate Service

The intermediate service is not as extensive as the Basic Service and can therefore be conducted by the customer, or by an authorised Service Workshop. Regardless of who conducts the service, it must be documented in the service book..

Number	Service point
1	Safety check.
2	Tyres, air pressure.
3	Engine oil and filter, see "Oil and filter" at page 13.
4	Oil level in HST, see "Oil and filter" at page 13.
7	Air filter, cleaning.
8	Cooling fins, clean.
9	Lubrication.

Edition	Manual	Chapter	Page
2014-12-09	Workshop Manual, GGP Park	1 General instructions	9

### 1.4.3 Basic service

The Basic Service must always be conducted by an authorized Service Workshop, and documented with a stamp in the service book.

Number	Service item
1	Safety check
2	Tyres, air pressure
3	Engine oil and filter, see "Oil and filter" at page 13.
4	Oil level in HST, see "Oil and filter" at page 13.
5	Belt transmissions, check
6	Battery check
7	Air filter for engine, see "Oil and filter" at page 13.
8	Cooling fins, clean
10	Transmission, check
11	Bearing boxes, check**
12	Exhaust system, check*
13	Electrical system, check*
14	Mower deck, check**
15	Blades, check**
16	Power take-off, check
17	Control check
18	Valve play***
19	Test driving

\*) See also "Safety check".

\*\*\*) See also the mower deck manual.

\*\*\*) See the engine manual.

Edition	Manual	Chapter	Page
2014-12-09	Workshop Manual, GGP Park	1 General instructions	10

## 1.5.4 Description of service points

### 1. Safety check

The machine is provided with safety devices/functions, related to the mechanical system and to the electrical system.

Test of the electrical system

Test	Status	Action	Result
1	Operator not sitting in seat. Brake pedal pressed.	Turn the key and make a start attempt.	Engine shall not start and "SIT DOWN" shall be displayed.
2	Operator sitting in seat. Brake pedal not pressed.	Turn the key and make a start attempt.	Engine shall not start and "PRESS BRAKE" shall be displayed.
3	Engine running. PTO magnetic clutch activated.	Operator rises from the seat.	The engine shall stop.

Test of the mechanical system

Test	Status	Action	Result
4	Fuel system and connections	Visual check	No leakage shall be observed.
5	Electrical cables	Visual check	All insulation OK and no mechanical damage.
6	Hydraulic system	Visual check	No leakage in hoses, connections or devices.
7	Drive the machine forwards and backwards.	Release the drive pedal.	The machine shall brake and stop
8	Driving test	Listen for abnormal noise and vibrations.	No abnormal noise or vibrations shall be observed.

Edition	Manual	Chapter	Page
2014-12-09	Workshop Manual, GGP Park	1 General instructions	11

## 2 Tyres, air pressure

Check the air pressure. Adjust if necessary. The recommended air pressure is designated at the floor mat.

## 3 Engine oil and oil filter

See the “Instructions for use”, delivered with the machine or “Instructions for use” at page 13. See also the engine manufacturer manual.

## 4 Oil, HST

See the owners manual, delivered with the machine.

## 5 Belt transmissions, check

Check the condition of all the belts and belt tensioners.

## 6 Battery check

Check the battery. Charge if necessary. See “Battery” at page 5.

## 7 Engine air filter

See the owners manual, delivered with the machine. See also the engine manufacturer manual.

## 8 Cooling fins

Remove protective covers from the engine and cleans between cooling fins. Use a brush and compressed air. See also the engine manufacturer manual.

## 9 Lubrication

Lubricate the articulation point (4 nipples) and all moving parts such as wires and levers. See also the instruction manual, delivered with the machine.

## 10 Transmission

Listen for abnormal noise. Check that there is no oil leakage.

## 11 Bearing boxes

Listen for abnormal noise from the bearings. Check that there are no wear, play or seizure.

## 12 Exhaust system

Check that there are no cracks, leakage or other damages. Check the attachment devices. See also the engine manufacturer manual.

## 13 Electrical system

Check that there are no damaged cables, contacts or other devices. Check that all cables are properly secured to the chassis and with cable holders. Check that there is no friction between cables and chassis, which can result in cable damage and short circuit.

Edition	Manual	Chapter	Page
2014-12-09	Workshop Manual, GGP Park	1 General instructions	12

## 14 Mower deck



### Warning!

**The blades are sharp. Always wear gloves when working with the blades to avoid injury.**

Check if there are collision damages or wear at the deck body and painting. Align, repair and touch up the painting as required.

Check the tightening of the bearing boxes screws and tighten.

Rotate the blades and check the the shafts are correct, not bent, no abnormal bearing noise and no plays.

Check the belts and their tensions, see section 4.

Check that the lifting mechanism moves evenly, not jammed and no play and that it locks in desired position.

## 15Blades



### Warning!

**The blades are sharp. Always wear gloves when working with the blades to avoid injury.**

Check that the blades are sharp. Sharpen as required.

## 16 Power take-off (PTO)

Check that the magnetic clutch engage the work equipment rotation in the desired time and that it not slips during normal load. Replace the clutch if necessary.

Check that the power take-off brake (if applicable) brakes the rotation movement in the desired time. Adjust if necessary.

## 17 Control check

Check that all controls function properly, that there are no jammings or excessive plays.

## 18 Valve play

See the engine manual regarding procedure and interval.

## 19 Test driving

Drive the machine during a few minutes and make the following attentions in different speeds and turnings in right and left. Check that all functions work evenly and proper and without any abnormal noise.

- Brake function
- Clutch function
- Power take-off
- Steering

Check that there are no abnormal vibrations.

Edition	Manual	Chapter	Page
2014-12-09	Workshop Manual, GGP Park	1 General instructions	13

## 1.5 Oil and filter

For information about oil- and filterdata for the engine and for the transmission, see the owners manual delivered with the machine. See also section 4 in this manual.

## 1.6 Technical specifications

For information about the technical specifications, see the owners manual delivered with the machine.

## 1.7 General tightening torque

Unless otherwise stated, the following tightening torque are applicable for screws and nuts on the machine:

Tightening torques

Thread	Torque
M5	5,7 Nm
M6	9,8 Nm
M8	24 Nm
M10	47 Nm

## 1.8 Instructions for use

Some procedures, e.g. changing engine oil, engine filter etc., are referred to the owner´s manual, delivered with the actual machine.

The owner´s manual can also be downloaded from GGP´s homepage. Go to [www.GGP.com](http://www.GGP.com) and click further to your actual language and heading.

Edition	Manual	Chapter	Page
2014-12-09	Workshop Manual, GGP Park	2 Chassis and body	1

## 2 Chassis and body

### Contents in this chapter

<b>2.1 Rear wheel.....</b>	<b>2</b>	<b>2.5 Steering cylinder .....</b>	<b>14</b>
2.1.1 Assembly .....	2	2.5.1 Dismantling .....	14
<b>2.2 Lubrication .....</b>	<b>3</b>	2.5.2 Assembly .....	14
<b>2.3 Covers.....</b>	<b>5</b>	<b>2.6 Articulating point .....</b>	<b>15</b>
2.3.1 Front engine covers.....	5	2.6.1 Dismantling .....	15
2.3.2 Covers around the articulating point.....	6	2.6.2 Assembly .....	16
2.3.3 Instrument covers .....	9	2.6.3 Replacing the yoke shaft .....	16
<b>2.4 Hydraulic pump.....</b>	<b>11</b>		
2.4.1 Dismantling.....	11		
2.4.2 Assembly .....	13		

### General

To facilitate the driving, handling of work equipment and to make it comfortable for the driver, the machines are equipped with a various number of aid equipments. These equipments are mainly the same for all the machines covered by this manual, but in some cases configured in different ways. Where divergences occur between the machines, particular instructions are given for each particular equipment.

This chapter gives a brief description of the equipments and describes their repair and replacements.

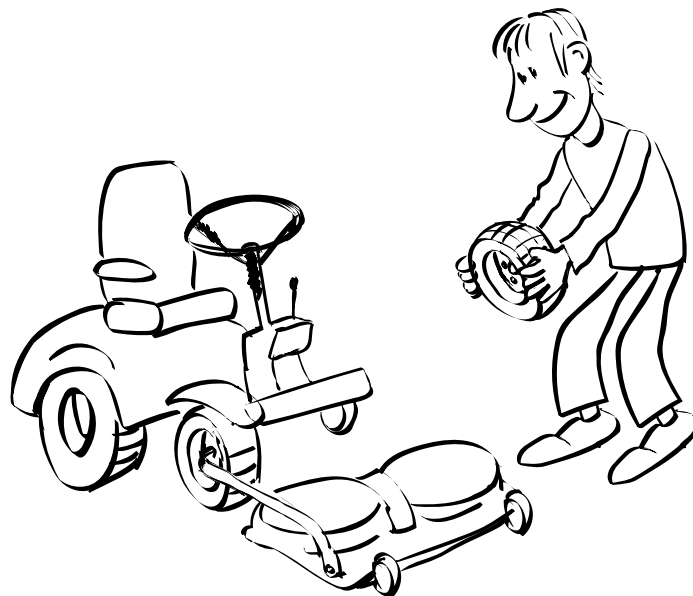

Edition	Manual	Chapter	Page
2014-12-09	Workshop Manual, GGP Park	2 Chassis and body	2

## 2.1 Rear wheel

### 2.1.1 Assembly

1. Push the hub on the shaft until it rests against the transmission body.
2. Assemble the washer and the circlip onto the shaft. The washer shall rest against the circlip.
3. Check the key and assemble it in the groove, against the washer.
4. Assemble the rear wheel without tightening the nuts.
5. Measure the distance (X) between the front wheels and adjust the rear hubs until the distance between the rear wheels is the same (X).

Pull out the hubs until the measure (Y) is the same at the both sides.

- Note!**  
 If the measures between the wheels front and rear not is the same, the machine will be hard to steer.

6. Tighten the two allen screws, using a 8 mm allen key.  
 The tightening shall be performed in two steps. Tighten first to 18 Nm and then, finally to a torque of 24 Nm.
7. Assemble the rear wheel and the protecting cover.

Assembly when tyre chains are used

To give place for the tyre chains, the distance X can be increased. If necessary until the hub rests against the washer.

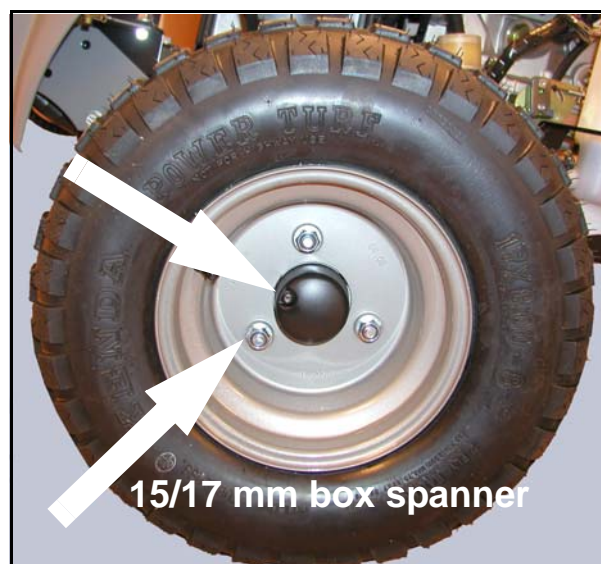
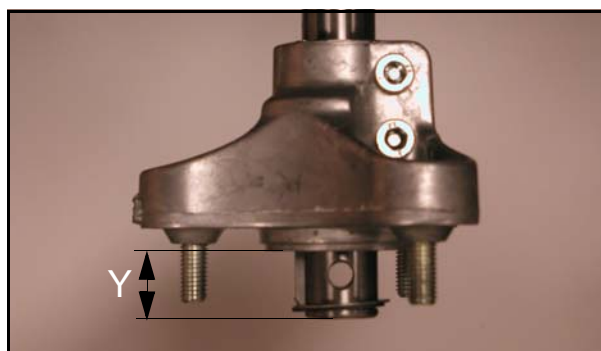
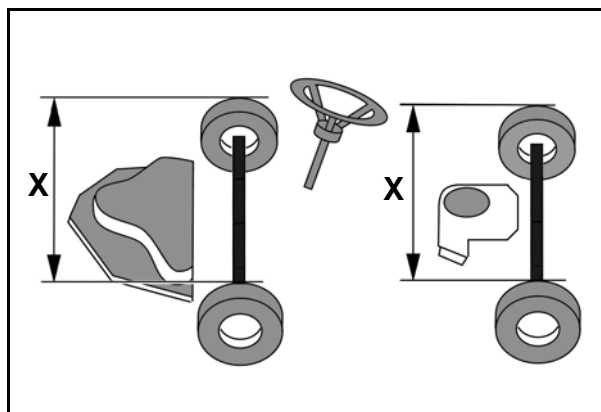





Edition	Manual	Chapter	Page
2014-12-09	Workshop Manual, GGP Park	2 Chassis and body	3

## 2.2 Lubrication

The lubrication must be performed in accordance with the service schedule. See the maintenance manual delivered with the machine.

- 

**Note!**  
Lubrication is equally important for a machine that is only used for a few hours per year.
- 

**Note!**  
The lubricant provides not only protection from wear but also from rust.
- 

**Note!**  
The machine should always be lubricated before prolonged storage.

The lubrication is described in the table below and in the figure at the next page.

Object	Measure	Pos
Wheel bearing	2 grease nipples. Use a grease gun filled with universal grease. Pump until the grease emerges.	A
Articulating point	4 grease nipples. Use a grease gun filled with universal grease. Pump until the grease emerges.	B
Steering	Lubricate the steering cylinder attachment.	C
Tensioning arms	Lubricate the bearing points with an oil can when each control is activated. Ideally carried out by two people.	D
Control cables	Lubricate the cable ends with an oil can when each control is activated. Must be carried out by two people.	E
Quick connections	2 grease nipples. Use a grease gun filled with universal grease. Pump until the grease emerges.	F

Edition	Manual	Chapter	Page
2014-12-09	Workshop Manual, GGP Park	2 Chassis and body	4

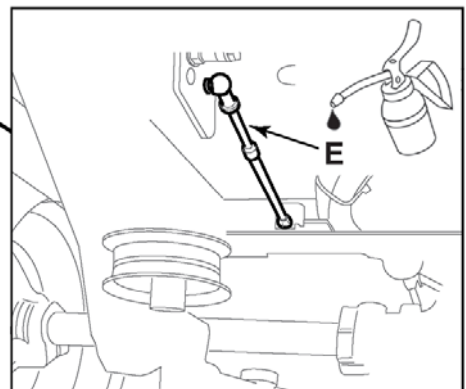
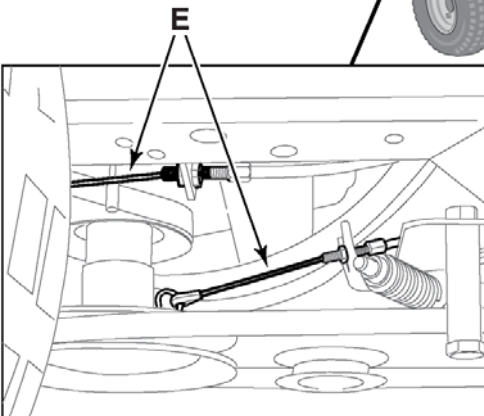
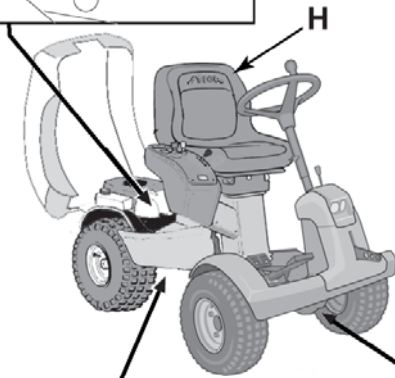
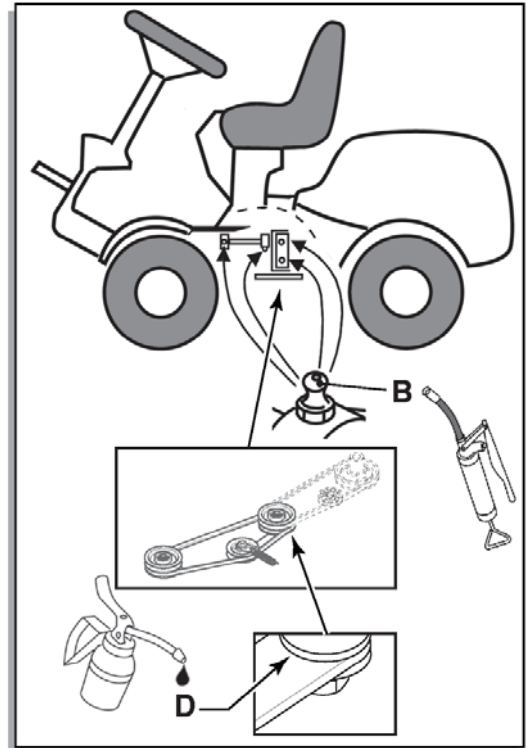
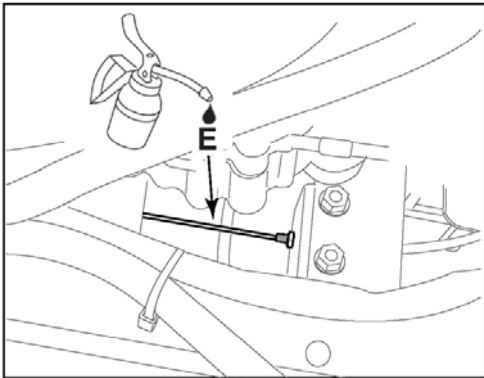
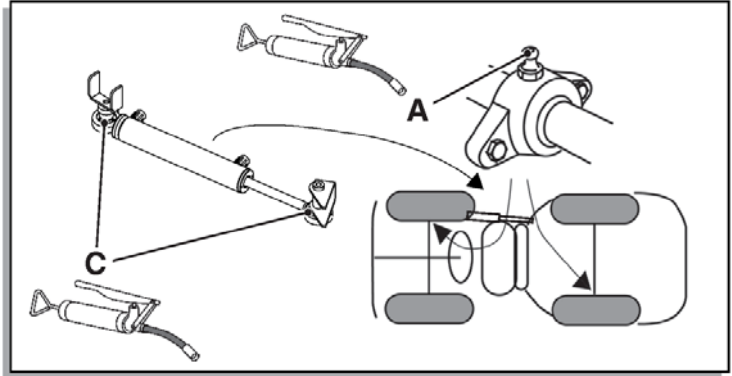
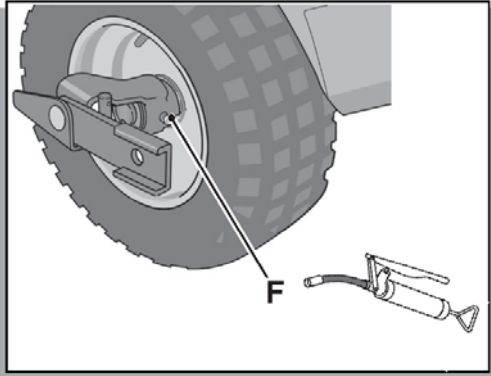

Edition	Manual	Chapter	Page
2014-12-09	Workshop Manual, GGP Park	2 Chassis and body	5

## 2.3 Covers

### 2.3.1 Front engine covers

#### Upper front cover

The upper front engine cover has to be removed in the following cases:

- Access to the battery.
- Access to the fuses.
- Removing of the lower case.

Dismantle the front upper cover as follows:

1. Loosen the two bayonet sockets, release the handle and fold back the upper cover. See the owners manual.
2. Unscrew 4 screws at each side. See the fig. Use a 4 mm allen key.



#### **Warning!**

**Petrol is highly inflammable. Never smoke when handling petrol. Never remove the filler cap while the engine is running or still warm or when hot objects are present.**

3. Remove the fuel cap.
4. Lift up and remove the cover.
5. Assemble the fuel cap.
6. Assemble the cover in the reverse order. Tighten the screws to XX Nm.

#### Lower front cover

The lower front engine cover has to be removed among others in the following cases:

- Access to the steering cylinder.
- Access to wires and hoses.
- Access to the tank attachments.

Dismantle the front lower cover as follows:

1. Remove the upper front cover. See above.
2. Unscrew 1 screw at each side. Use a 4 mm allen key and preferably a mirror to locate the screws. See the fig.

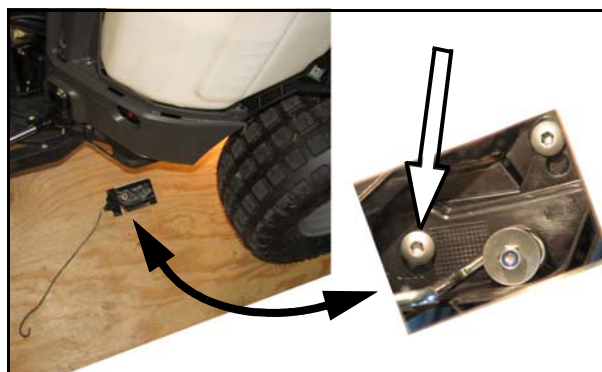
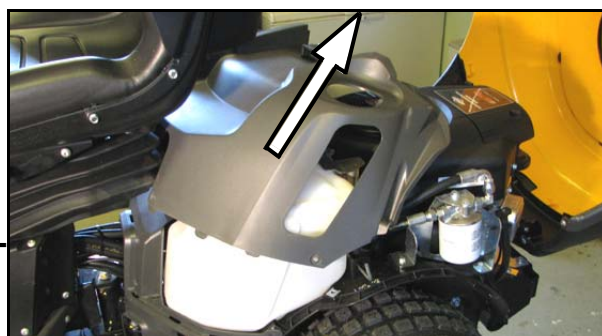

Edition	Manual	Chapter	Page
2014-12-09	Workshop Manual, GGP Park	2 Chassis and body	6

**Warning!**  
 Don't try to remove the cover without dismantle the tank. This will destroy both the cover and the seat bellow.

**Warning!**  
 Petrol is highly inflammable. The fuel cap must be on and tight when moving the tank.

3. Move the cover forwards until the tank attachment wing nuts are free and remove the nuts.
4. Place the tank upon the engine and remove the cover.
5. Assemble the cover in the reverse order. Tighten the screws to XX Nm.

**6. Important steps during the assembly of the lower cover and the tank:**

First set the cover in place without fasten it with its screws.

Then set the tank in place and fasten it with its attachments.

Finally fasten the lower cover with its two screws.

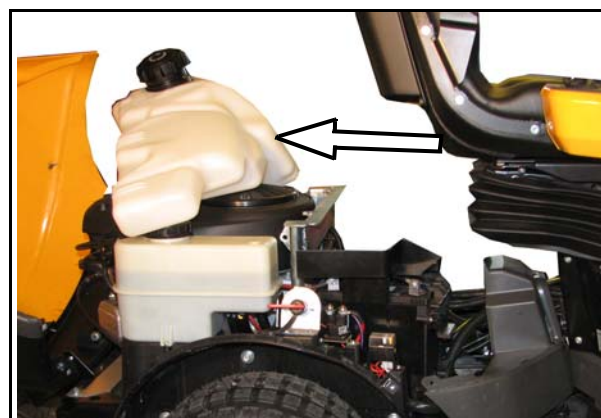
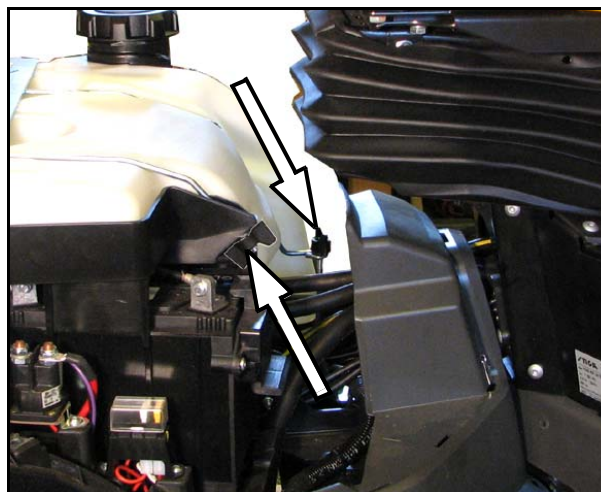

**2.3.2 Covers around the articulating point**

**Dismantling**

Dismantle the covers around the articulating point as follows:

1. Unscrew the two M6 nuts, one at each side and remove the protecting bar. Use a mirror to locate the nuts.

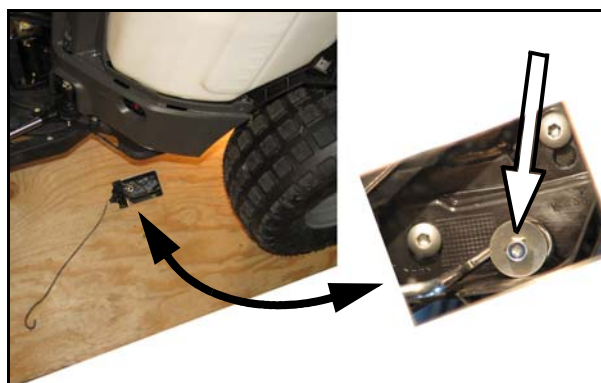



Edition	Manual	Chapter	Page
2014-12-09	Workshop Manual, GGP Park	2 Chassis and body	7

2. Unscrew one M6 nut from the under side and one screw and remove the left floor cover.



3. Unscrew one M6 nut from the under side and one screw and remove the left front art. cover.

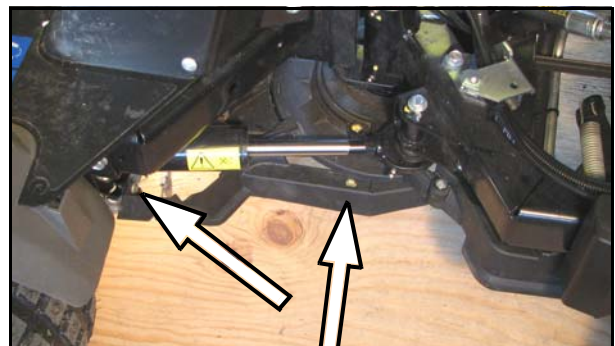

4. Unscrew the screw under the right floor cover. See the figure. Remove the cover. Use a mirror to locate the screw. under the floor.

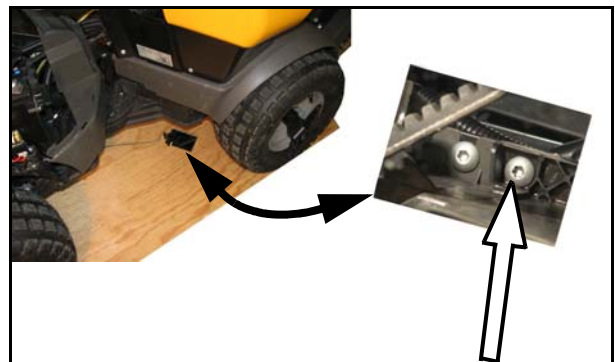

5. Unscrew the nut and unhook the spring. See the fig.  
Unscrew also the nut from the underside behind the pulley.  
Remove the cover and the pulley with parts.

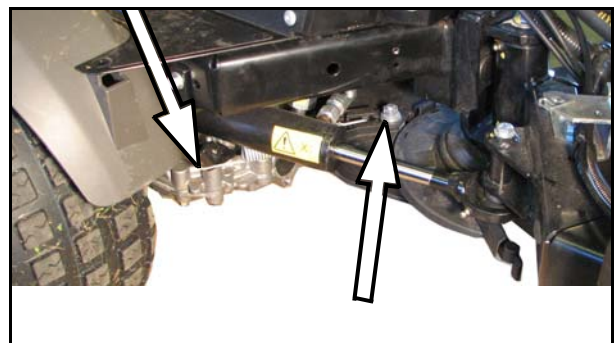

6. Unscrew the remaining screws and nuts and remove the rest of the cover parts. Use a mirror to find the screws and nuts.

Edition	Manual	Chapter	Page
2014-12-09	Workshop Manual, GGP Park	2 Chassis and body	8

7. If necessary, dismantle the right cover according to the figure.

The following cover screws are shown in the figure:

- Visible to the right, close to the art. point.
- From the underside. See in the mirror
- One M6 nut with washer accessible from the wheel department.

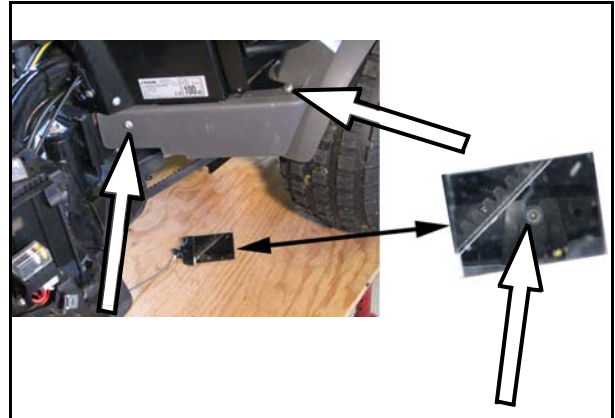

7. Check that the fuel cock is correct placed in the opening of the cover. See the figure.

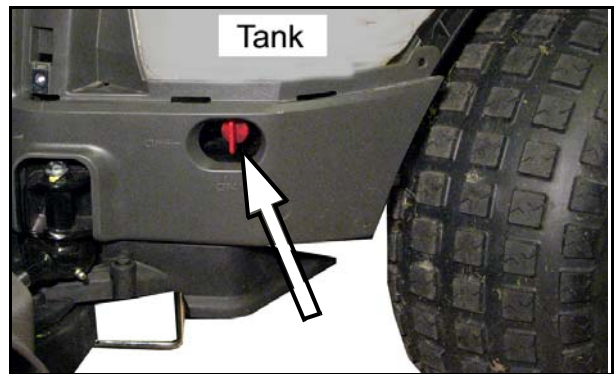

### Assembly

The assembly of the covers are performed in the reverse order as follows:

1. Start with the rear parts and the parts around the art. point. See the fig.

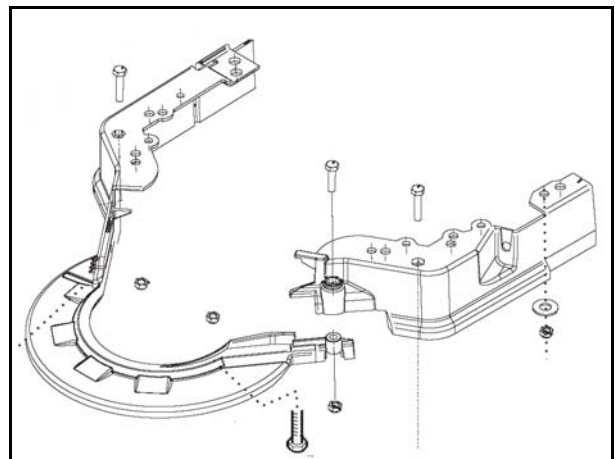

Edition	Manual	Chapter	Page
2014-12-09	Workshop Manual, GGP Park	2 Chassis and body	9

2. Then assemble the pulley with covers. Note the fitting of the pulley and its sleeves.

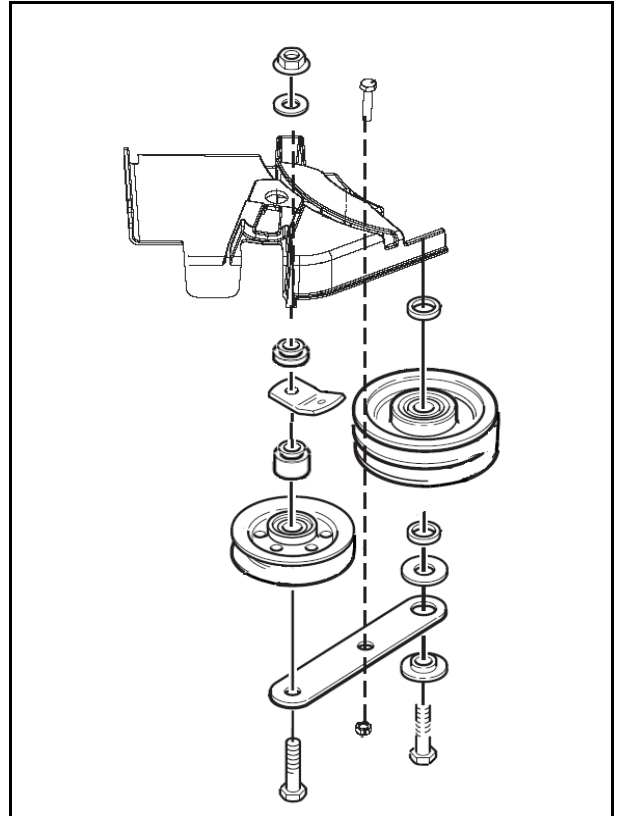

3. Fit the front protecting bar.

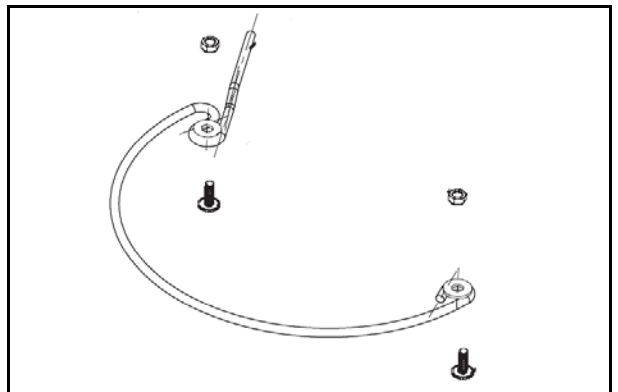

4. Assemble the remaining covers and the rear protecting bar.

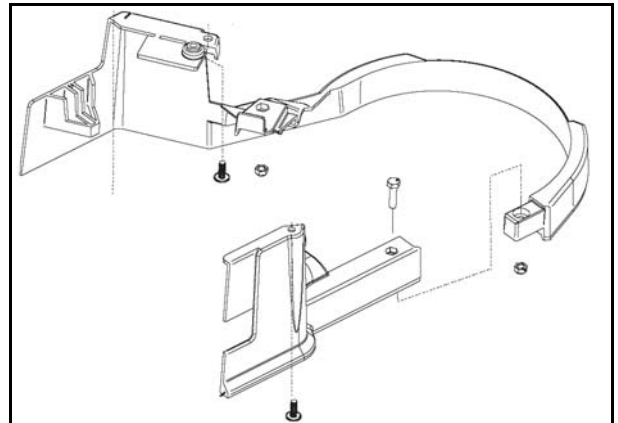

Edition	Manual	Chapter	Page
2014-12-09	Workshop Manual, GGP Park	2 Chassis and body	10

Locating of washers at the rear protecting bar.

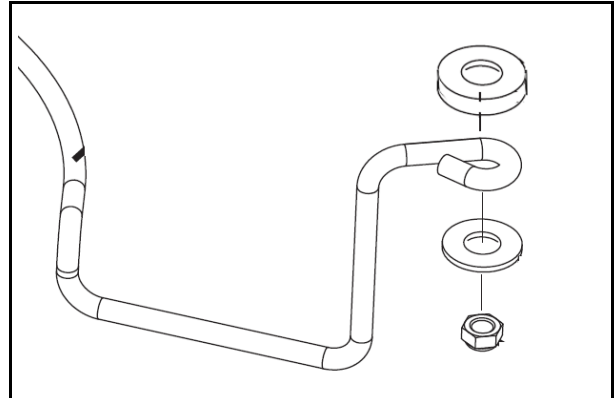

### 2.3.3 Instrument covers

To get access to instrument levers, electronics and wires, etc, the instrument covers have to be dismantled.

**Warning!**  
 **If the seat is folded without the rivets removed, the bellow will be destroyed.**

Dismantle the covers as follows:

1. Unscrew two M8 screws (A), one at each side and pull out four bellow rivets (B), two at each side.
2. Fold the seat forwards, unscrew 6 screws and remove the outside cover.

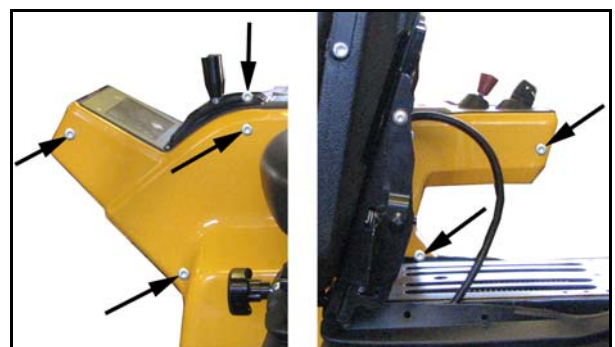
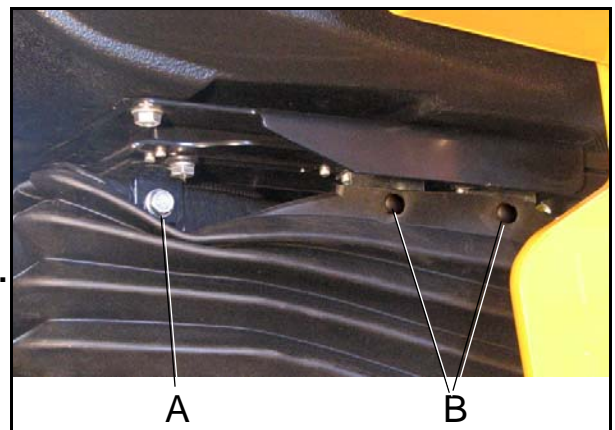

3. Unscrew the four inside screws with an 8 mm spanner and remove the inside cover.
4. The assembly is performed in the reverse order.

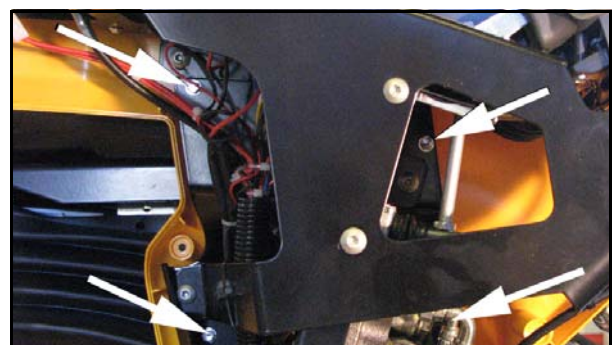



Edition	Manual	Chapter	Page
2014-12-09	Workshop Manual, GGP Park	2 Chassis and body	11

## 2.4 Hydraulic pump

This section will describe the replacement procedure for the external hydraulic pump in 4WD Park machines.

### 2.4.1 Dismantling

1. Block up the machine. Use a lifting table or highjack and yokes.
2. Activate the parking brake.
3. Discharge the oil in the hydraulic system. See the owners manual.
4. Remove the following parts:
  - Front engine covers with fuel tank. See "Front engine covers" page 5.
  - Plastic cover behind the art. point at the right side. See "Covers around the articulating point" page 6.
5. Turn the steering wheel fully at left and remove the speed control cable from the hydraulic pump by backing off the nut. Use a 8 mm spanner.
6. Back off the circlip from the release lever rod and disconnect the rod from the lever.
7. Use a large polygrip (A) and hold the pump pulley in a secu rely grip. Fit the polygrip around the belt, not direct to the pylley. Back off the pulley nut with a 17 mm sleeve. See the figure.

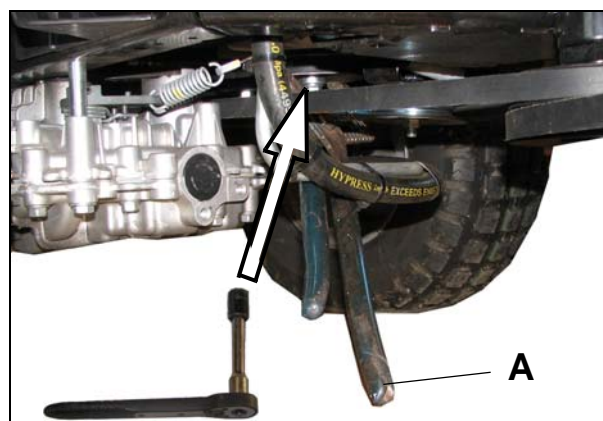
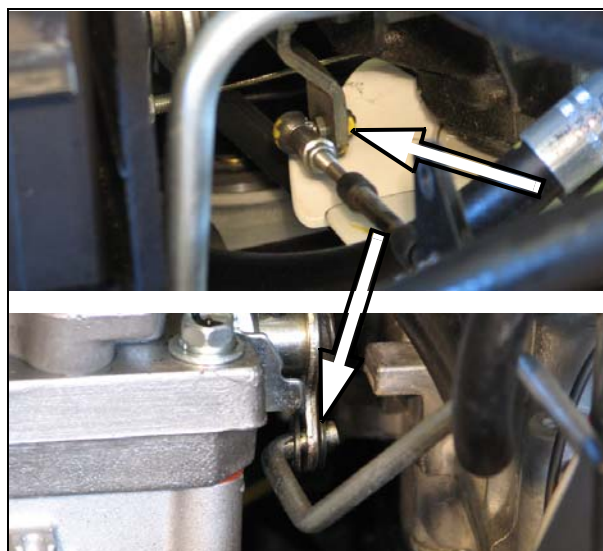

Edition	Manual	Chapter	Page
2014-12-09	Workshop Manual, GGP Park	2 Chassis and body	12

**Warning!**  
 **Be carefully not to damage the plastic fan during the removal.**

8. Remove the following parts from the pump shaft:

- Nut
- Washer
- Pulley
- Distance sleeve
- Fan
- Distance sleeve

9. Place a collecting tray under the pump for collecting residual oil from the pump and hoses.

**Warning!**  
 **Do not spill any oil on the drive belts during the disconnection of hoses and tubes.**

**Warning!**  
 **Keep clean when handling hydraulic parts. Dirt in the oil will cause malfunctions and breakdowns.**

10. Disconnect all hoses and tubes from the hydraulic pump. Always use two spanners, one to hold the respective connection in the pump and one to loosen the nut. See the figure.



11. Remove the pump from the chassis by unscrewing the two M10 mounting nuts and screws. Use two 17 mm spanners. See the figure.

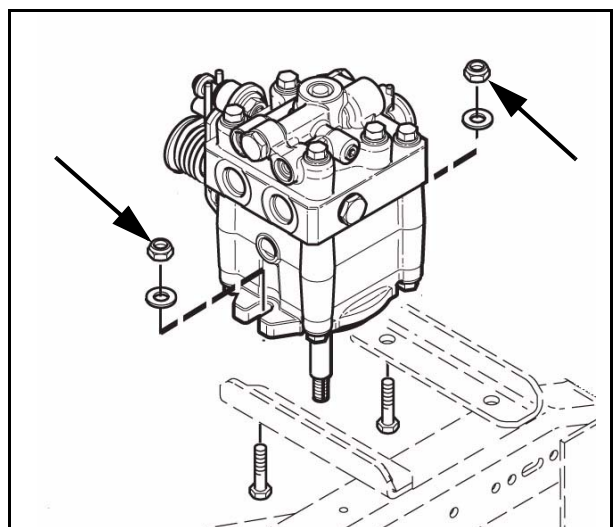

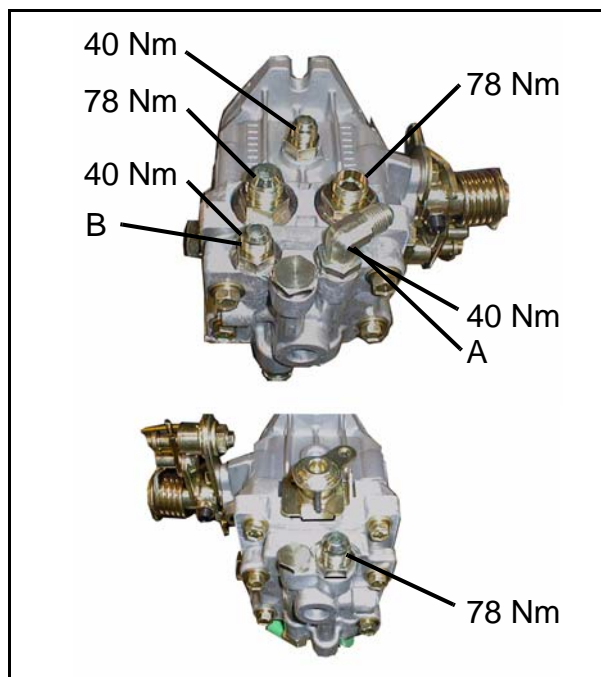

Edition	Manual	Chapter	Page
2014-12-09	Workshop Manual, GGP Park	2 Chassis and body	13

12. Place and fasten the pump in a table vice. Loosen the adapters from the pump.
13. Screw out the adapters and insert them in the corresponding places in the new pump one at a time. Check or replace the O-rings.
14. Place and fasten the new pump in a table vice. Tighten the adapters to torques according to the figures.  
When tightening the angle adapter (A), adjust it to 45° according to the horizontal line. Use one 14 mm and one 19 mm spanner.



## 2.4.2 Assembly

**Warning!**  
 **Keep clean when handling hydraulic parts. Dirt in the oil will cause malfunctions and breakdowns.**

**Warning!**  
 **Be carefully not to damage the plastic fan during the assembly.**

Assemble all parts in the reverse order.

**Note!**  
 One distance sleeve (C) at each side of the fan.

Adjust the speed cable. See section 6.

When all parts are fitted and all actual tightening torques are applied, fill new oil and bleed the hydraulic system. See the owners manual.

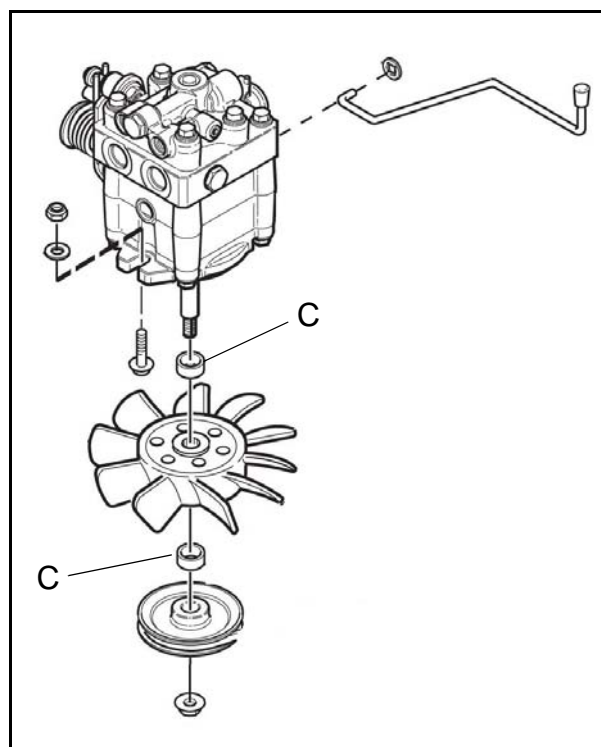

Edition	Manual	Chapter	Page
2014-12-09	Workshop Manual, GGP Park	2 Chassis and body	14

## 2.5 Steering cylinder

### 2.5.1 Dismantling

1. Block up the machine. Use a lifting table or highjack and yokes.
2. Activate the parking brake.
3. Dismantle all covers at the left side. See "Covers" page 5.
4. Block up the front left wheel and remove it to get access to the front cylinder attachment.
5. Place a collecting tray under the steering servo for collecting residual oil from the hoses.

**Warning!**  
 Do not spill any oil on the drive belts during the disconnection of hoses and tubes.

**Warning!**  
 Keep clean when handling hydraulic parts. Dirt in the oil will cause malfunctions and breakdowns.

6. Dismantle the hose collecting bar (A).
7. Loosen the cylinder hoses (B) from the steering servo.
8. Remove the screws holding the steering cylinder and take out the cylinder with hoses.
9. Note the angle of the hoses and remove them from the cylinder. Fit the hoses in the same angle to the new cylinder.

### 2.5.2 Assembly

1. All the assembly is performed in the reverse order.
2. After the assembly, start the machine and turn the steering wheel fully left and fully right several times until the steering works properly.
3. Check the hydraulic oil and fill up as necessary. See the owners manual.

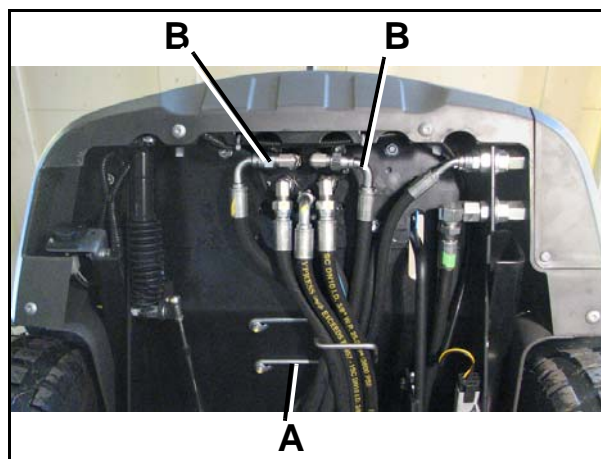
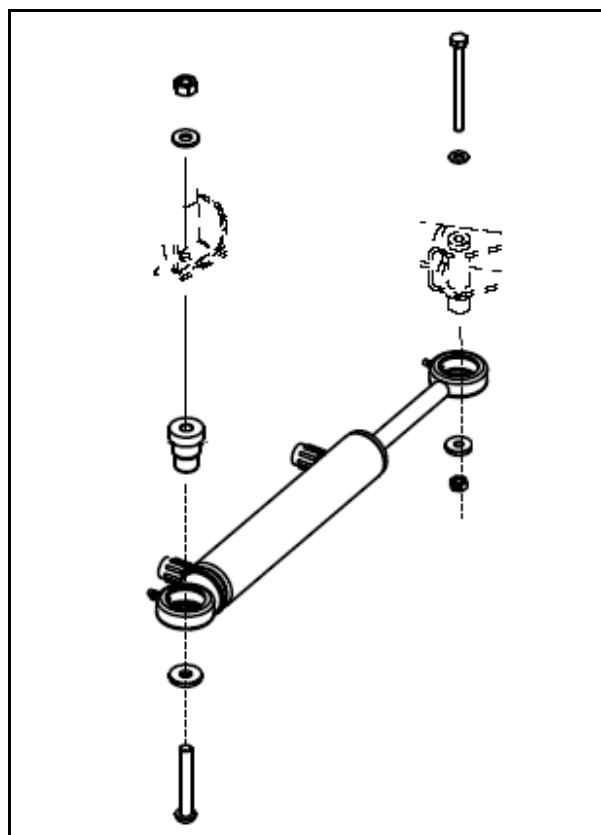



Edition	Manual	Chapter	Page
2014-12-09	Workshop Manual, GGP Park	2 Chassis and body	15

## 2.6 Articulating point

### 2.6.1 Dismantling

1. Block up the machine. Use a lifting table or highjack and yokes.
2. Activate the parking brake.
3. Dismantle all covers from the art. point. See "Covers" page 5.
4. Turn the steering wheel max to the left and loosen the rear steering cylinder attachment.
5. Work off the belts from the art. point pulley, unscrew the lower screw and remove the pulley from its shaft.



#### Warning!

**Check that the frames are securely supported while they are separated.**

6. Support the front and rear frame close to the art. point with two hydraulic jack or similar.
7. Unscrew the upper screw and press the shaft downwards and separate the frames.
8. Move the rear frame sideways until it comes free from the fork.
9. Press out the two spheric plain bearings from the rear frame.  
Use a mandrel if necessary.

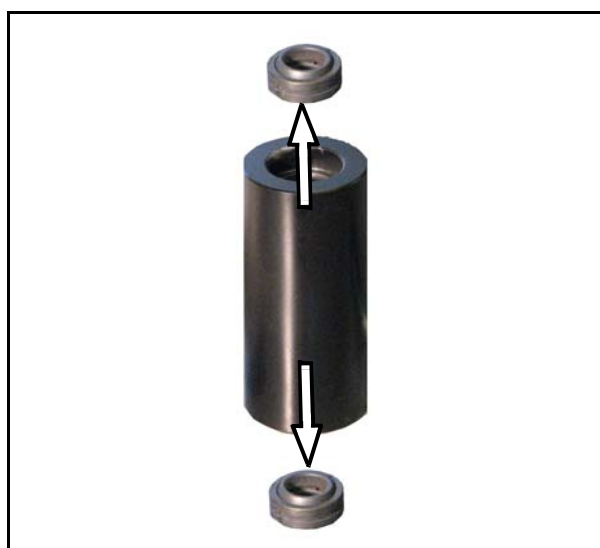
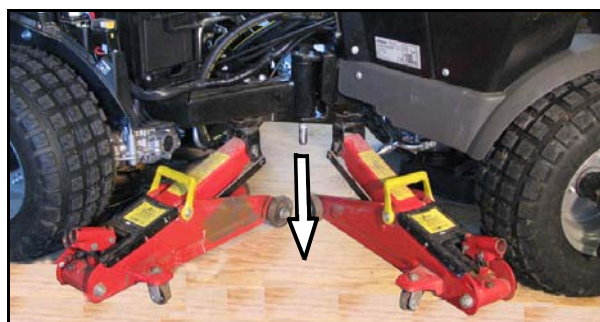
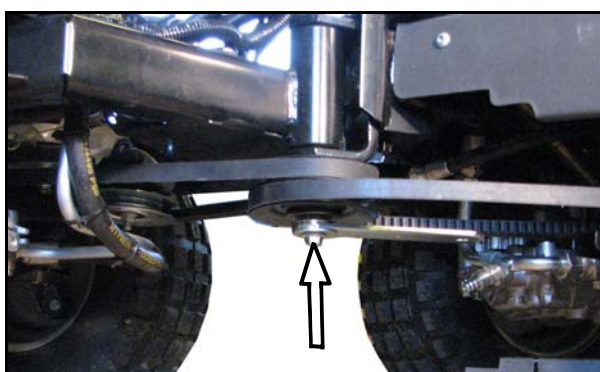
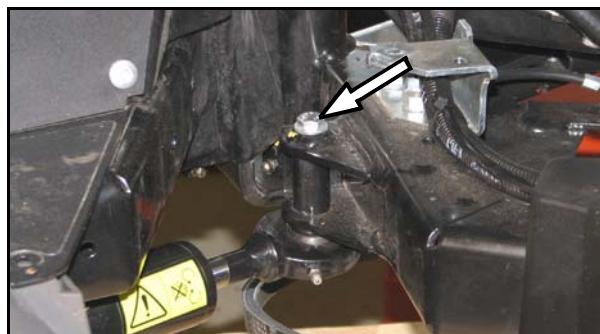

Edition	Manual	Chapter	Page
2014-12-09	Workshop Manual, GGP Park	2 Chassis and body	16

## 2.6.2 Assembly

1. All the assembly is performed in the reverse order.
2. Note the support sleeve between the spheric plain bearings,
3. Lubricate the spheric plain bearings before installation.

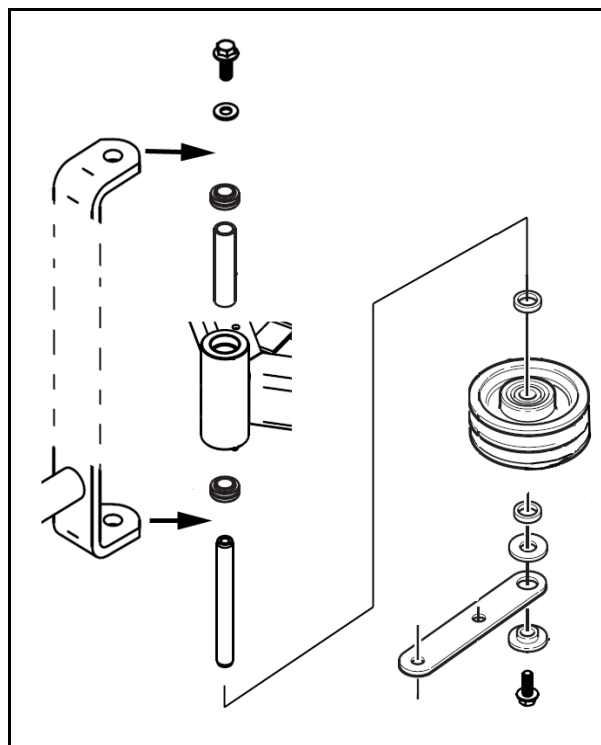

## 2.6.3 Replacing the yoke shaft

1. Apart the art. point as described in "Articulating point" page 15.
2. Use an angle grinder and cut the yoke shaft close to the rear bearing. See the figure.
3. Grind off the painting from the rear part of the shaft and pull out the pieces backwards.
4. Turn the front part of the shaft until the dowel can be forced out and dismantle the parts.
5. The new yoke shaft is assembled in the reverse order.
6. Note that the bearing surfaces shall be lubricated before installation.

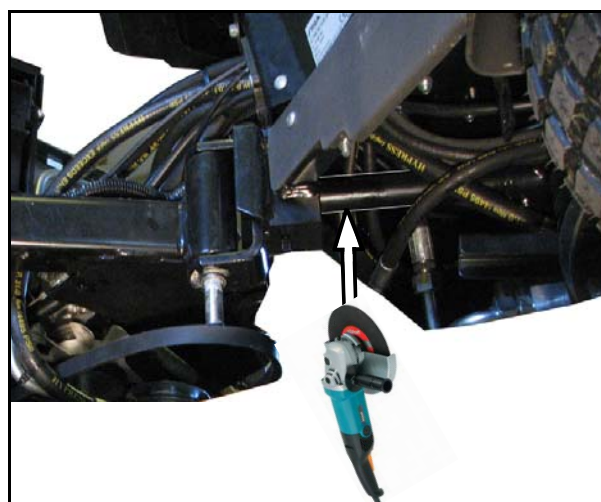
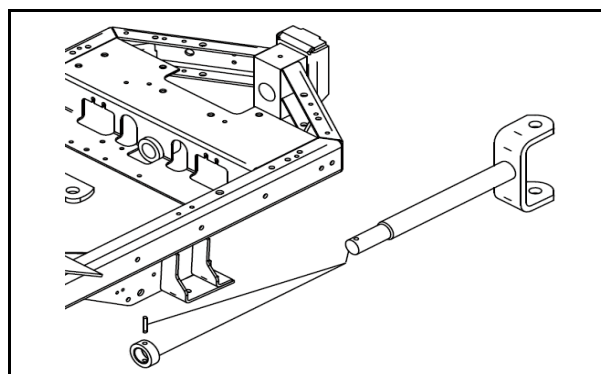

Edition	Manual	Chapter	Page
2014-12-09	Workshop Manual, GGP Park	3 Steering	1

## 3 Steering

### Contents in this chapter

3.1 Description .....2

### General

The machines are equipped with hydraulic assisted steering system, type “Orbitrol”.

This chapter contains only a brief description of the complete configuration of the steering system.

A deeper description of the hydraulics is given in section 4.



Edition	Manual	Chapter	Page
2014-12-09	Workshop Manual, GGP Park	3 Steering	2

### 3.1 Description

The hydraulic pump (A) feeds the steering servo (B) with an oil pressure. The steering servo adjust the oil flow to and from the respective side of the steering cylinder (C).

Thus the steering cylinder push or pull the left side of the frames, bringing them to set in a desired angle.

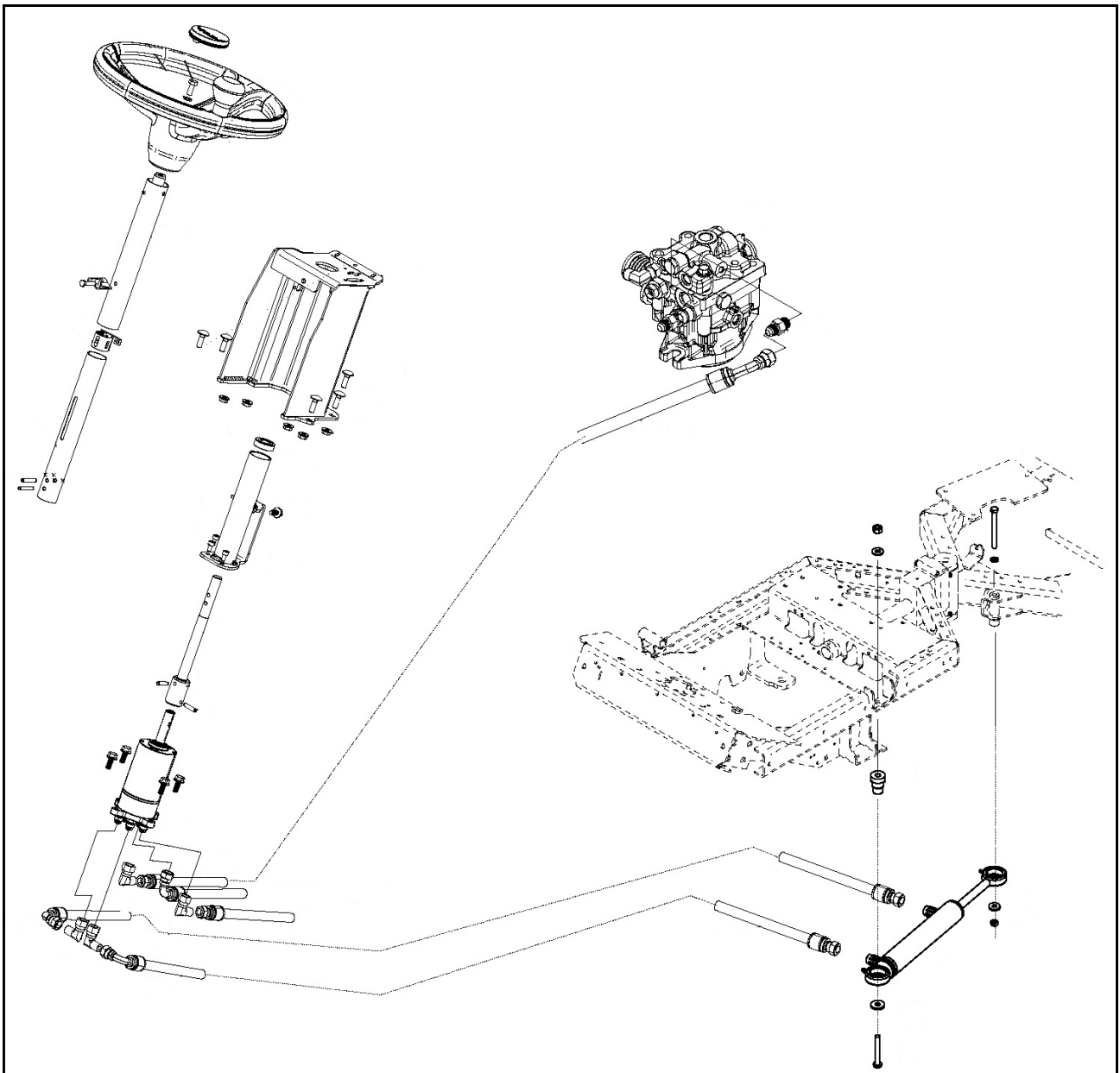



Edition	Manual	Chapter	Page
2014-12-09	Workshop Manual, GGP Park	4 Hydraulic system	1

## 4 Hydraulic system

### Contents in this chapter

<b>4.1 Safety</b> .....	<b>2</b>	<b>4.5 Hydraulic implement lifter and hydraulic outputs</b> .....	<b>13</b>
<b>4.2 Configuration</b> .....	<b>2</b>	4.5.1 Physic description.....	13
<b>4.3 Power transmission</b> .....	<b>3</b>	4.5.2 Functional description.....	15
4.3.1 Physical description.....	3	<b>4.6 Trouble shooting</b> .....	<b>20</b>
4.3.2 Functional description .....	4	4.6.1 Drive system.....	20
<b>4.4 Hydraulic steering</b> .....	<b>7</b>	<b>4.7 Auxiliary hydraulic</b> .....	<b>22</b>
4.4.1 Physic description .....	7	4.7.1 Change of transmission	
4.4.2 Functional description .....	9	oil .....	24

### General

The four wheel drive Park machines are equipped with hydraulic power transmission. I.e. the engine drives an hydraulic pump, which pumps oil through the rear and front axle drives. The hydraulic pump is separate located in front of the engine.

The front axle and rear axle are connected in series, which means that the front wheels and rear wheels are forced to rotate at the same speed. To make turning easier, both axles are equipped with a differential.

The machines are also equipped with hydraulic assisted steering and implement lifter. Front-mounted implements are powered via drive belts.

This chapter contains a description of the hydraulic system, trouble shooting to isolate faults and information about adjustments and corrective measures.



Edition	Manual	Chapter	Page
2014-12-09	Workshop Manual, GGP Park	4 Hydraulic system	2

## 4.1 Safety

**Hydraulic oil under pressure can be very dangerous if hoses, lines or other distribution parts are leaking. To avoid personal injuries, always wear protection gloves and protection goggles during works with the hydraulic system.**

**Before starting the motor, place the machine outdoors or install an extraction device for the exhaust fumes. Otherwise the personnel will be poisoned.**

**Cleanliness is mandatory at all works with the hydraulic system. Foreign substances and contaminations will jeopardize the function and reliability of the system. Always protect and close openings of hoses, lines and connections when replacing components.**

## 4.2 Configuration

The machines are equipped with Hydraulic steering where the force is transferred to the frames by a hydraulic cylinder. See "Hydraulic steering" at page 7.

The power transmission, the hydraulic assisted steering, implement lifter and the hydraulic connections (Aux1 and Aux2) work with the same oil, but in separate parallel systems. Therefore, the descriptions are divided in the following headings:

The following sections will explain the physical arrangement of the hydraulic components and give a functional description.

Edition	Manual	Chapter	Page
2014-12-09	Workshop Manual, GGP Park	4 Hydraulic system	3

## 4.3 Power transmission

### 4.3.1 Physical description

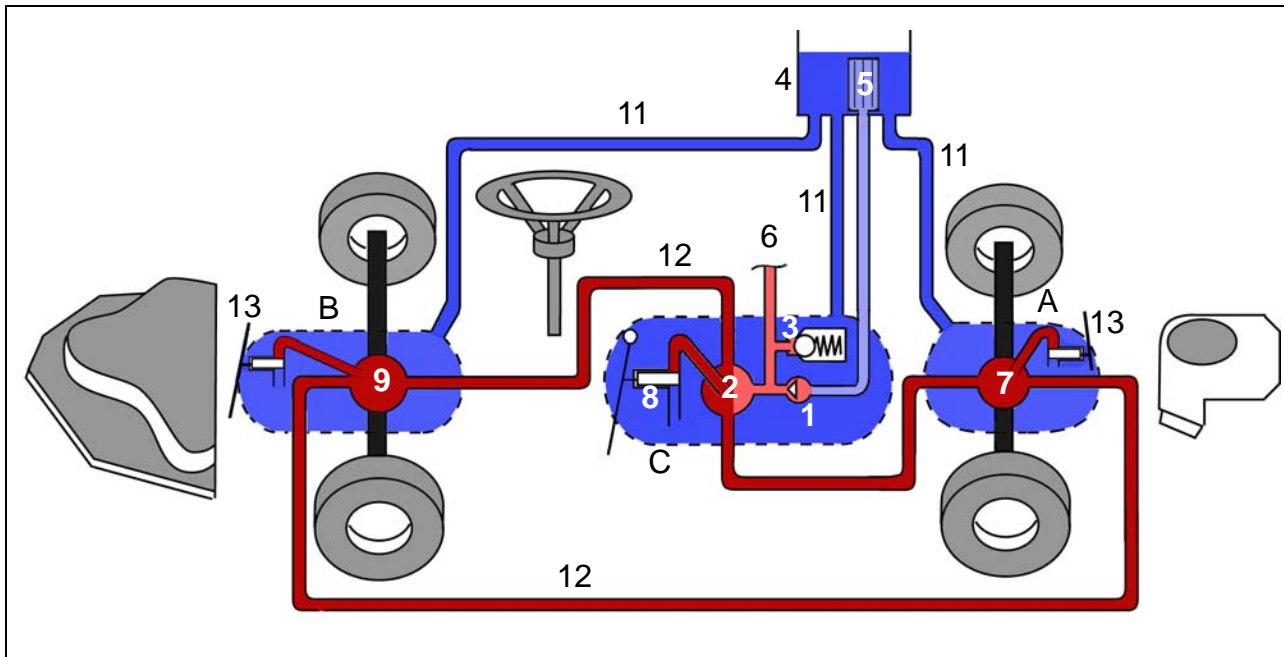

- |   |  |
|---|--|
| <p>A. Rear axle drive with its hydraulic motor (7).</p> <p>B. Front axle drive with its hydraulic motor (9).</p> <p>C. Hydraulic pump. The parts 1-3 and 8 below are positioned in the hydraulic pump.</p> <p>1. Charge pump, max 55 bar</p> <p>2. Main pump.</p> <p>3. Pressure relieve valve for the charge pressure.</p> <p>4. Oil tank.</p> <p>5. Oil filter.</p> <p>6. Connection to the auxiliary hydraulics (steering valve and implement lifter).</p> <p>7. Hydraulic motor in the rear axle drive (A).</p> | <p>8. By-pass valve in the hydraulic pump (C).</p> <p>9. Hydraulic motor in the front axle drive (B).</p> <p>11. Leak flow lines.</p> <p>12. Main flow lines.</p> <p>13. By-pass valve (only used when oil change)</p> |
|---|--|
- Colour - Pressure**
- Red is the feeding pressure to the main pump and to the auxiliary hydraulics.
  - Dark red is the working pressure to the hydraulic motors.
  - Blue is the atmospheric pressure in the oil tank and housings.
  - Light blue is below the atmospheric pressure (pump

Edition	Manual	Chapter	Page
2014-12-09	Workshop Manual, GGP Park	4 Hydraulic system	4

### 4.3.2 Functional description

#### Driving

The oil flows when driving forwards respectively backwards are shown in the diagrams below.

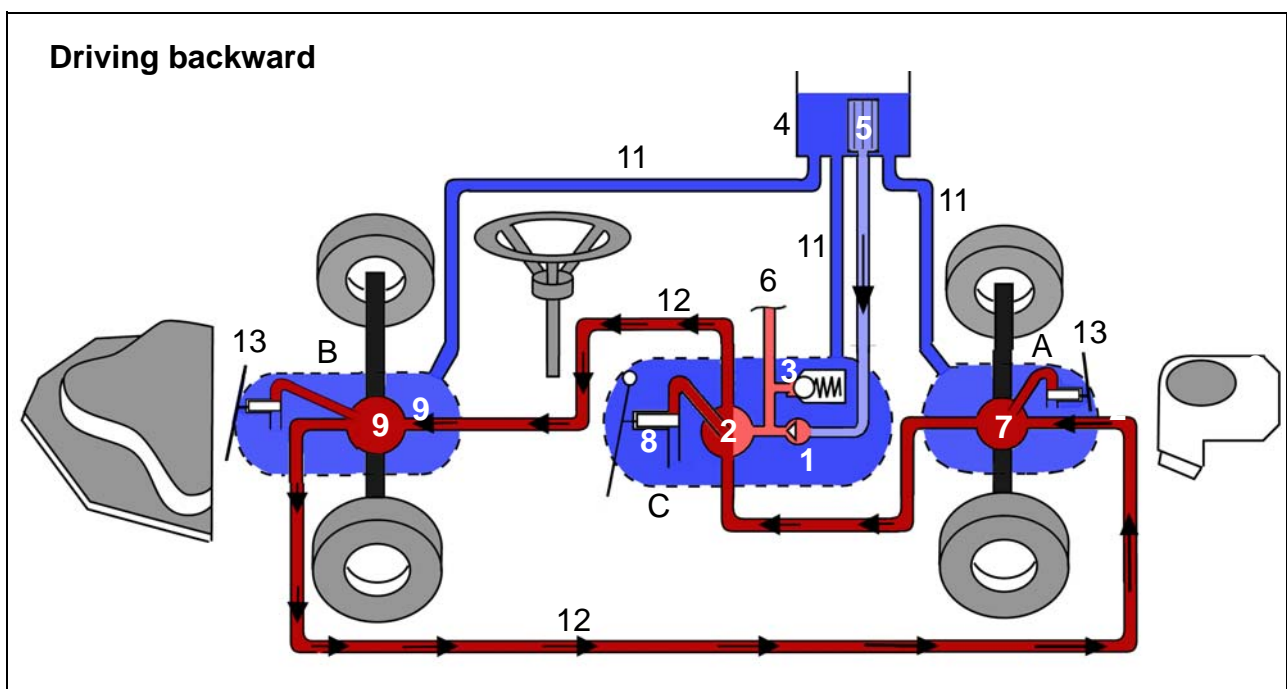
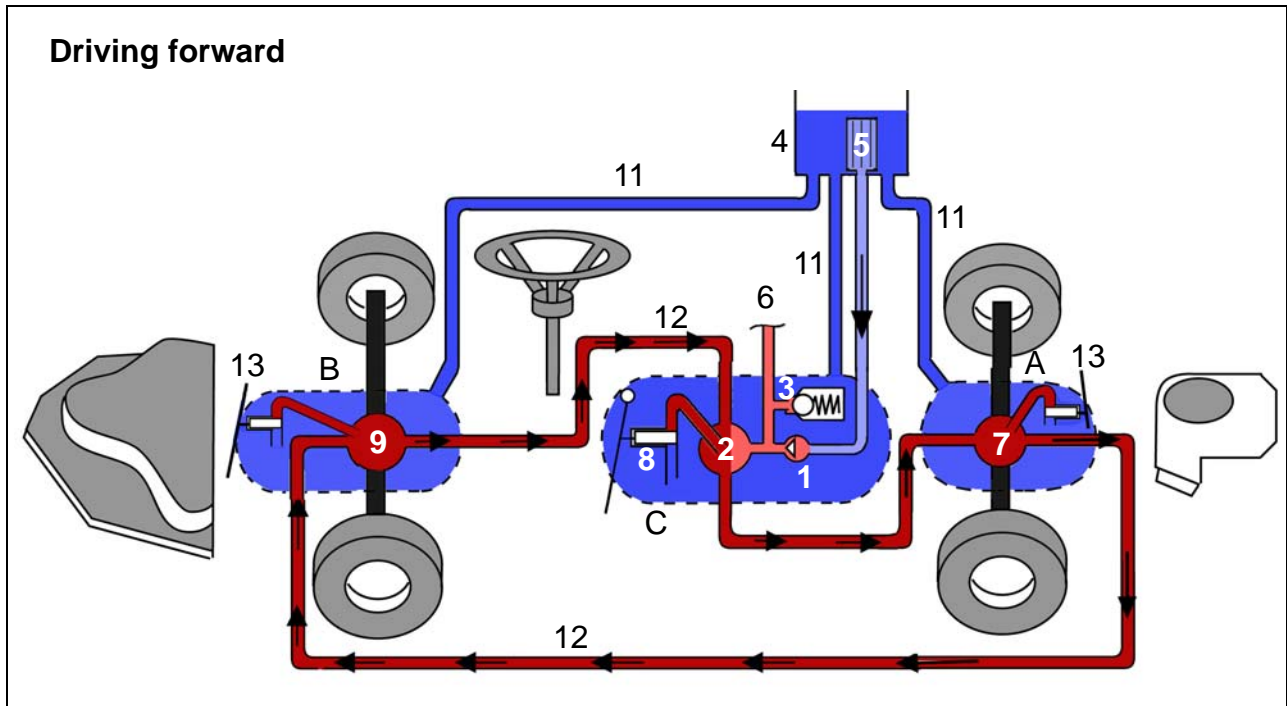

Edition	Manual	Chapter	Page
2014-12-09	Workshop Manual, GGP Park	4 Hydraulic system	5

The charge pump (1) and the main pump (2) are integrated into one unit, the hydraulic pump (C) which is located separat in front of the engine.

The engine drives the the hydraulic pump (C) with a constant speed. The charge pump (1) is feeding the main pump (2) with max 55 bar The oil, fed into the main pump during operation, is a replacement for the leak oil from the front and rear axle drives (A and B) and the main pump (2).

The charge pump sucs its oil from the oil tank (4) and through the filter (5).

The oil flow and the flow direction through the main pump (2) - front hydraulic motor (9) - rear hydraulic motor (7) is controlled by the speed pedal, mechanical connected to the main pump (2). The main pump pressure is depending on the power requirements at the wheel axles and is limited by the engine power.

The hydraulic motors and the hydraulic pump have a small oil leakage (1-4%), which increases with increased power requirement (increased pressure). The leakage oil is collected inside the unit housings an forwarded back to the oil tank through the leak flow lines.

The motors are connected in serie with the rear hydraulic motor (7) first, when driving forwards. This means, due to the leakage in the rear motor, that the machine under normal conditions drives on the rear wheels only. When the rear wheels begin to slip (rotate with 1-4% higher speed than the front wheels) also the front wheels start to drive and the slipping is avoided. This fact is not noticed by the operator, since the machine is driven with its four wheels after demand.

### By-pass valve

The main pump (2) is equipped with a by-pass valve (8), connected to its clutch release lever. When the by-pass valve is open, the main pump is disconnected from the oil circuit by an open passage out into the housing.

The pressure drop over the pump is such neutralized and the oil can flush free in the system. See the figure.

The by-pass valve is intended to make it possible to push the machine without heavy resistance from the main pump.

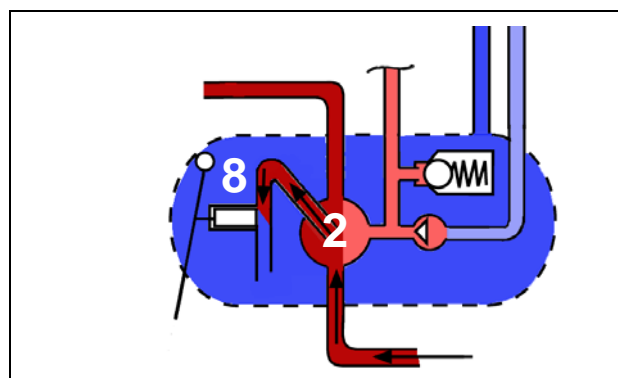
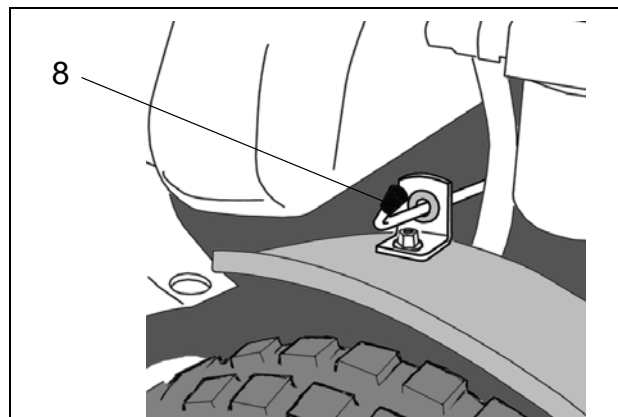

Edition	Manual	Chapter	Page
2014-12-09	Workshop Manual, GGP Park	4 Hydraulic system	6

## Charge pump

The charge pump has two tasks:

- To feed the auxiliary hydraulic with max 55 bar
- To feed the main pump with its initial pressure, 1,5-2,5 bar.

### Auxiliary hydraulic

The charge pump (1) sucks oil from the oil tank (5).

When the auxiliary hydraulics are in use, the pressure in the out line (3) is limited to 35-45 bar by the relief valve (4).

### Feeding the main pump

The line (2) feeds oil to the main pump respective suction lines (depending on driving forwards or backwards) through the respective back valves (6). The pressure in the line (2) is limited to 1,5-2,5 bar by the relief valve (7).

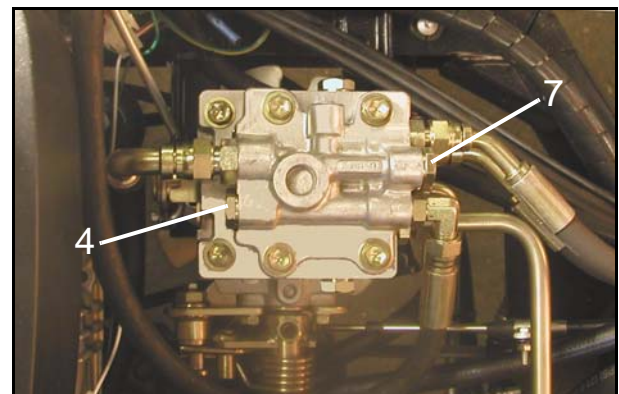
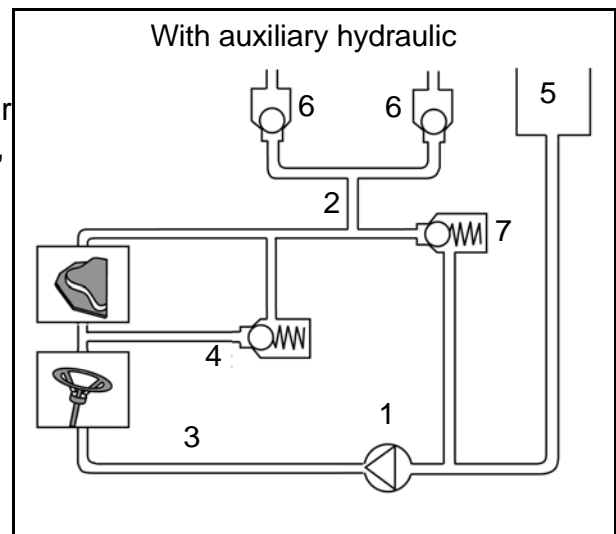



Edition	Manual	Chapter	Page
2014-12-09	Workshop Manual, GGP Park	4 Hydraulic system	7

## 4.4 Hydraulic steering

### 4.4.1 Physic description

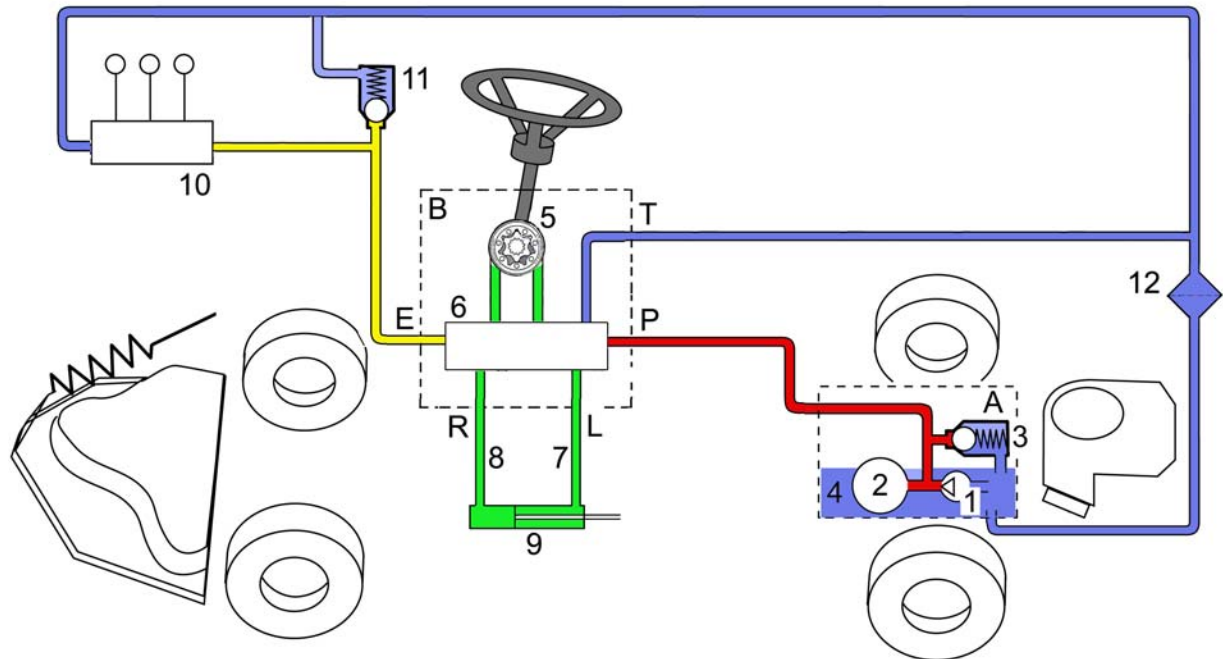

A. Hydraulic pump. The parts 1-3 below are positioned in the hydraulic pump.

1. Charge pump, 49-51 bar.
2. Main pump.
3. Pressure relieve valve for the charge pressure.
4. Oil tank

B. Steering valve including the following:

5. Gear
6. Distributor

#### Terminals at the steering valve:

- P. Inlet from the hydraulic pump for auxiliary hydraulics.
- T. Outlet to the tank for leak oil and oil from the passive side of steering cylinder when turning.
- E. Outlet to other auxiliary hydraulics.
- L. Outlet to the steering cylinder. Pressure when turning left.
- R. Outlet to the steering cylinder. Pressure when turning right.

7, 8. Pressure lines to transmit the steering power.

9. Steering cylinder.

10. Auxiliary hydraulics.

11. Pressure relieve valve 31-33 bar.

12. Filter.

#### Colour - Pressure

 Red is the feeding pressure to the steering valve and auxiliary hydraulics.

 Yellow is the feeding pressure to auxiliary hydraulics connected after the steering valve.

 Blue is the atmospheric pressure in the oil tank and lines.

 Green lines can act both as pressure lines and return lines, depending on the movements.

Edition	Manual	Chapter	Page
2014-12-09	Workshop Manual, GGP Park	4 Hydraulic system	8

## B. Steering valve

The steering valve is a complete unit. The steering valve transmits the oil flow to the auxiliary hydraulics. The valves in the steering valve are not adjustable. The steering valve has 5 hydraulic terminals. The following items are included in the steering valve:

### 5. Oil pump

The oil pump has two purposes:

- To activate the steering cylinder when no hydraulic pressure is present (motor not running)
- To transmit the high pressure oil to the steering cylinder (motor is running)

### 6. Distributor

The distributor consists of a number of valves, which are controlled by the actuating of the steering wheel.

### 9. Steering cylinder

The steering cylinder is connected to the front and rear frame at the right side of the machine. By expanding respective retracting it brings the frames to angle into desired directions.

### 11. Pressure valve

The pressure relieve valve shall ensure that the back pressure of the steering valve is limited to 31-33 bar. This became the maximal pressure to the remaining auxiliary hydraulics. These facts ensure that the steering valve always works properly, even when the auxiliary hydraulics is overloaded.

### 12. Filter

The filter is located on the return line from the auxiliary hydraulics. This means that all the oil from the auxiliary hydraulict passes the filter. The filter has a cleaning degreee of 10 micron.



Edition	Manual	Chapter	Page
2014-12-09	Workshop Manual, GGP Park	4 Hydraulic system	9

## 4.4.2 Functional description

### Not turning, steering wheel not actuated

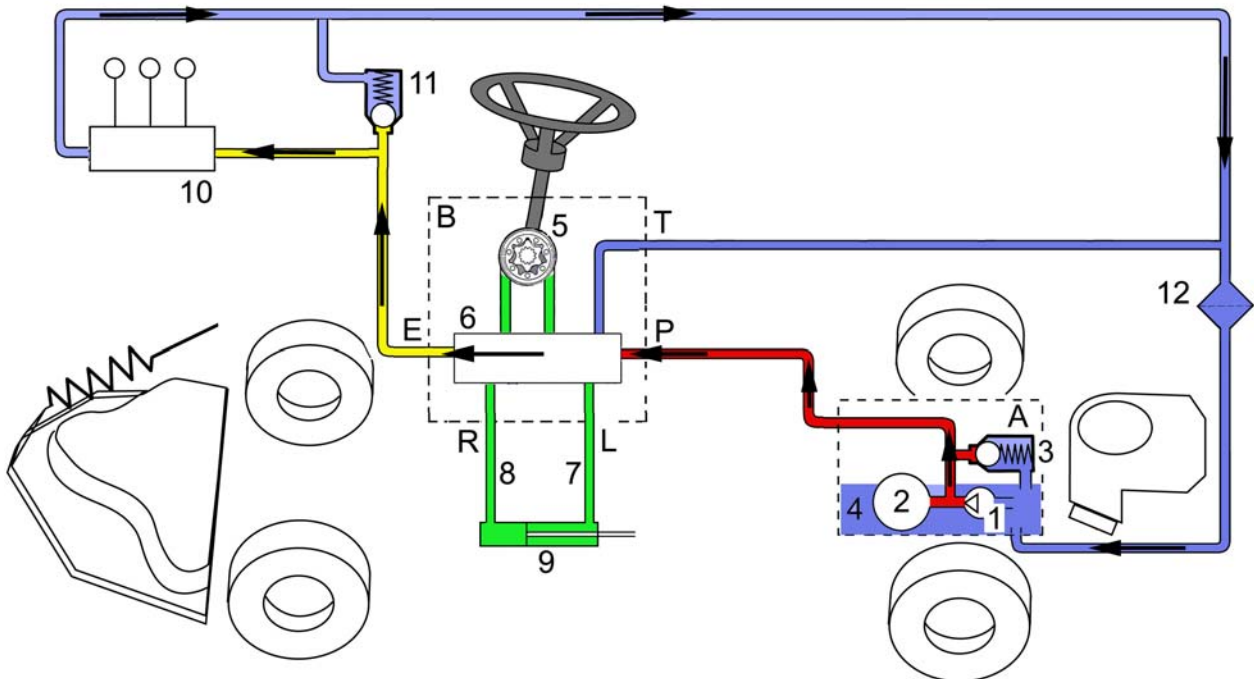

A. Hydraulic pump. The parts 1-3 below are positioned in the hydraulic pump.

1. Charge pump, 49-51 bar.
2. Main pump.
3. Pressure relieve valve for the charge pressure.

B. Steering valve including the following:

5. Gear
6. Distributor

7, 8. Pressure lines to transmit the steering power.

9. Steering cylinder.

10. Auxiliary hydraulics.

11. Pressure relieve valve 31-33 bar.

12. Filter

#### Colour - Pressure

— Red is the feeding pressure to the steering valve and auxiliary hydraulics.

— Yellow is the feeding pressure to auxiliary hydraulics connected after the steering valve.

— Blue is the atmospheric pressure in the oil tank and lines.

— Green lines can act both as pressure lines and return lines, depending on the movements.

The charge pump (1) is sucking oil from the tank and pumping it into the steering valve. Since the steering is not in use, the oil flows without resistance through the steering valve, distributor and to the remaining auxiliary hydraulics. From the auxiliary hydraulics, the oil is flowing back to the tank via the filter (12).



Edition	Manual	Chapter	Page
2014-12-09	Workshop Manual, GGP Park	4 Hydraulic system	11

## Turning to the right

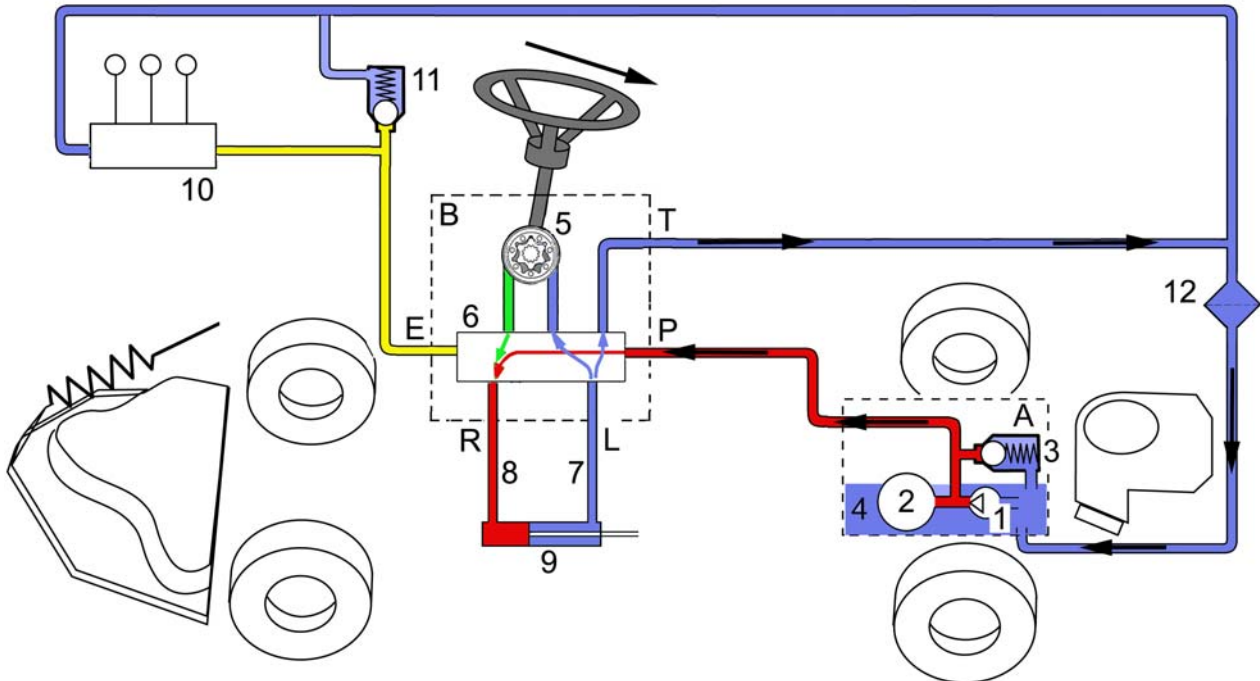

A. Hydraulic pump. The parts 1-3 below are positioned in the hydraulic pump.

1. Charge pump, 49-51 bar.
2. Main pump.
3. Pressure relieve valve for the charge pressure.

B. Steering valve including the following:

5. Gear
6. Distributor

7, 8. Pressure lines to transmit the steering power.

9. Steering cylinder.

10. Auxiliary hydraulics.

11. Pressure relieve valve 31-33 bar.

12. Filter

### Colour - Pressure

 Red is the feeding pressure to the steering valve and auxiliary hydraulics.

 Yellow is the feeding pressure to auxiliary hydraulics connected after the steering valve.

 Blue is the atmospheric pressure in the oil tank and lines.

 Green lines can act both as pressure lines and return lines, depending on the movements.

The distributor (6) consists of a number of valves, which are controlled by the actuating of the steering wheel. Since the entire steering valve (B) is an unrepairable spare part, the exact function of these valves are not explained in this description. Only the oil flows through the unit is presented in order to explain the system function.

Edition	Manual	Chapter	Page
2014-12-09	Workshop Manual, GGP Park	4 Hydraulic system	12

### Turning with motor stopped

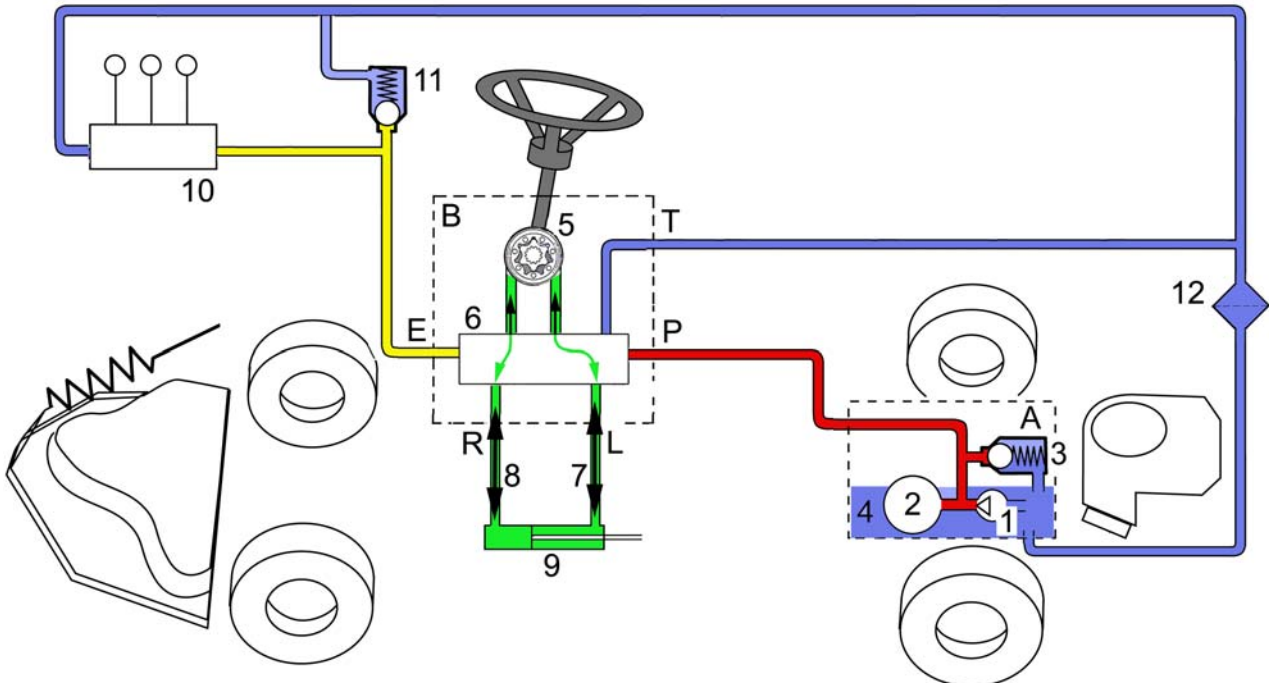

- A. Hydraulic pump. The parts 1-3 below are positioned in the hydraulic pump.
1. Charge pump, 49-51 bar.
  2. Main pump.
  3. Pressure relieve valve for the charge pressure.
4. Oil tank
- B. Steering valve including the following:
5. Gear
  6. Distributor
- 7, 8. Pressure lines to transmit the steering power.

9. Steering cylinder.
10. Auxiliary hydraulics.
11. Pressure relieve valve 31-33 bar.
12. Filter

#### Colour - Pressure

- Red is the feeding pressure to the steering valve and auxiliary hydraulics.
- Yellow is the feeding pressure to auxiliary hydraulics connected after the steering valve.
- Blue is the atmospheric pressure in the oil tank and lines.
- Green lines can act both as pressure lines and return lines, depending on the movements.

When using the steering wheel with the motor stopped (no oil pressure), the oil flows between the cog wheel pump (5) and the steering cylinder (9) only. All other oil flows are cut off.

Edition	Manual	Chapter	Page
2014-12-09	Workshop Manual, GGP Park	4 Hydraulic system	13

## 4.5 Hydraulic implement lifter and hydraulic outputs

### 4.5.1 Physic description

The outputs and levers are shown below.

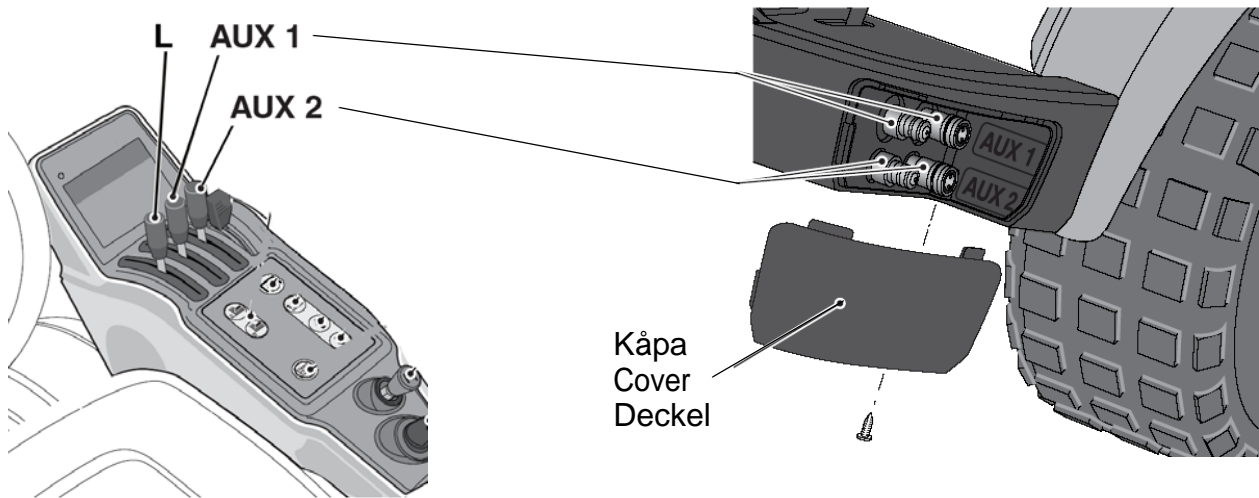

Edition	Manual	Chapter	Page
2014-12-09	Workshop Manual, GGP Park	4 Hydraulic system	14

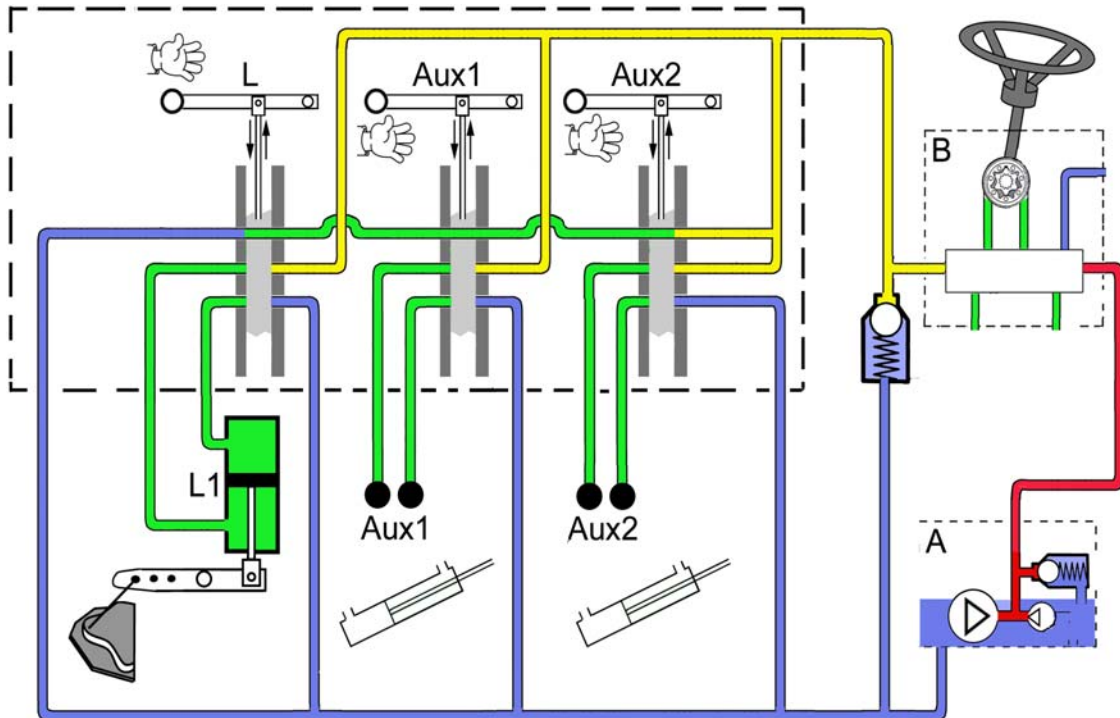

- A. Hydraulic pump.
- B. Steering valve.
- L. Control lever for the implement lifter.
- L1. Implement lifter cylinder.
- 11. Pressure relieve valve 31-33 bar.

Aux1 and Aux2:  
Control levers for the actual hydraulic connections.

Colour - Pressure

- Red is the feeding pressure to the steering valve and auxiliary hydraulics.
- Yellow is the feeding pressure to auxiliary hydraulics connected after the steering valve.
- Blue is the atmospheric pressure in the oil tank and lines.
- Green lines can act both as pressure lines and return lines, depending on the movements.



Edition	Manual	Chapter	Page
2014-12-09	Workshop Manual, GGP Park	4 Hydraulic system	15

## 4.5.2 Functional description

### Auxiliary hydraulics not in use

#### Operation state:

- Motor is running in full speed.
- The steering wheel is not actuated.
- The implement lifter is not activated.

The hydraulic pump (A) is forcing oil through the steering valve (B), and the opened valves (Aux2, Aux1 and L).

The oil flow is indicated with arrows in the figure below. Since neither of the items are working, the resistance can be ignored and the pressure is very low (<1 bar).

In the normal condition, the lifting cylinder (L1) is locked in its set position, because no oil can flow out or in since the oil lines are shut by the slide.

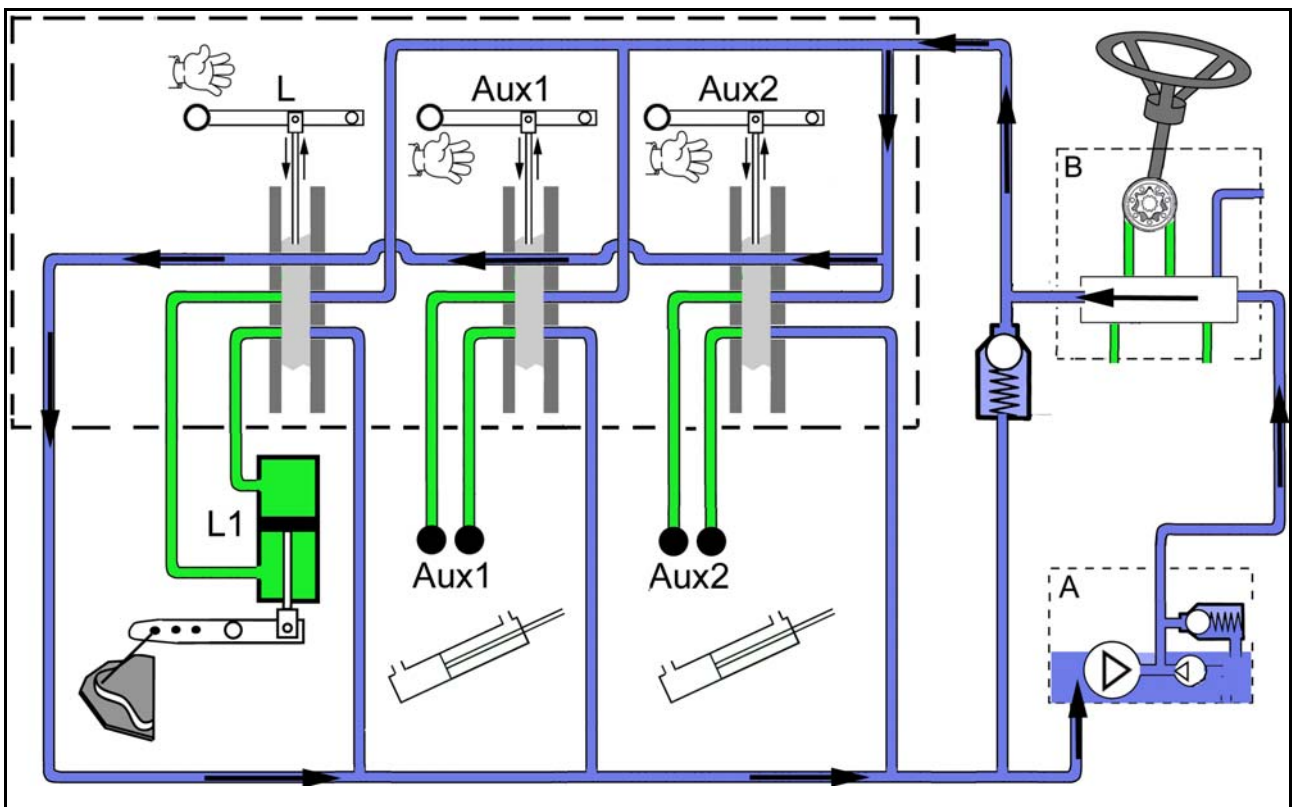

Edition	Manual	Chapter	Page
2014-12-09	Workshop Manual, GGP Park	4 Hydraulic system	16

### Implement lifter upwards

#### Operation state:

- Motor is running in full speed.
- The implement lifter is activated upwards.

The operator has actuated the hand lever (L) to its raising position, which moves the slide to change the hole pattern between the connections in the valve. The hole pattern is adapted for the raising procedure (crossed in the figure below). Oil forces through the slide and presses out the piston in hydraulic cylinder (L1).

When the piston in cylinder (L1) is fully extended and the hand lever still is activated, the oil will flow only through the valve (11) and a noise will be heard from the valve.

When the hand lever is released, valve will return to its neutral position and the system switches over to its normal state. The piston in the hydraulic cylinder (L1) is then locked in its actual position.

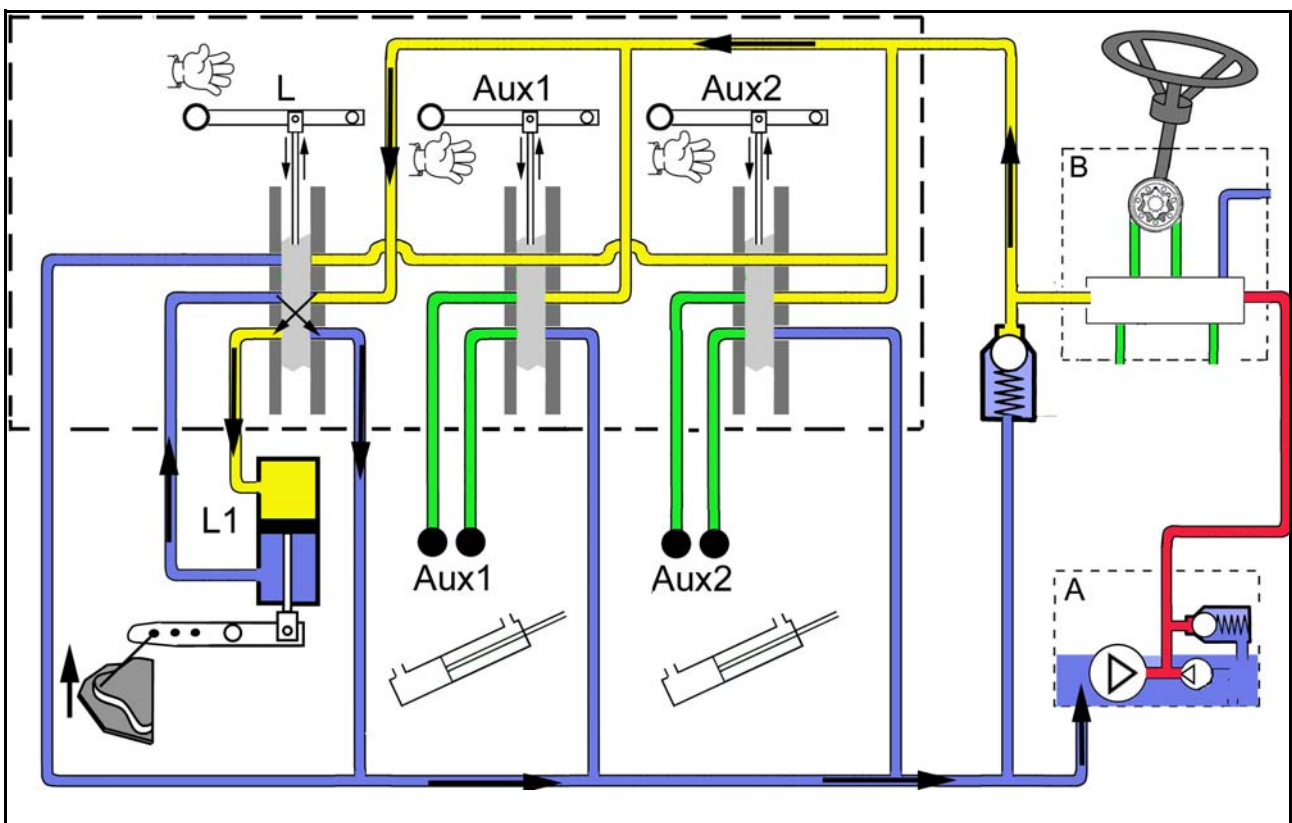

Edition	Manual	Chapter	Page
2014-12-09	Workshop Manual, GGP Park	4 Hydraulic system	17

## Implement lifter downwards

### Operation state:

- Motor is running in full speed.
- The implement lifter lever is activated downwards.

The operator has actuated the hand lever (L) to its lowering position (one step forwards), which moves the slide to change the hole pattern between the connections in the valve. The hole pattern is adapted for the lowering procedure. Oil forces through the slide and presses back the piston into the hydraulic cylinder (L1).

In this arrangement, the implement is forced down, irrespective its weight.

When the piston in cylinder (L1) has reached its bottom position and the hand lever still is activated, the oil will flow only through the valve (11) and a noise will be heard from the valve.

When the hand lever is released, the connected valve will return to its normal position and the system switches over to its normal state. The piston in the hydraulic cylinder (L1) is then locked in its actual position.

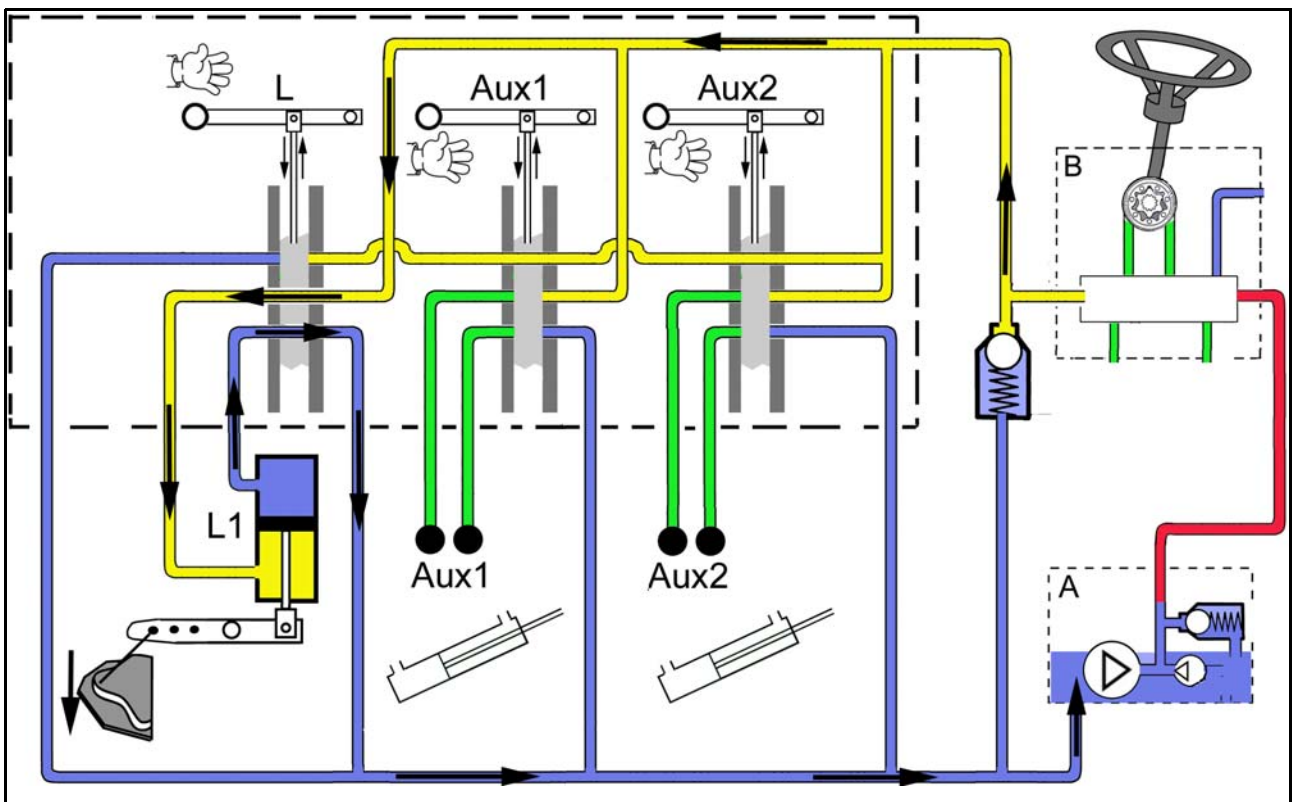

Edition	Manual	Chapter	Page
2014-12-09	Workshop Manual, GGP Park	4 Hydraulic system	18

## Floating position

### Operation state:

- Motor is not running or is running in full speed.
- The implement lifter is in its floating position.

The operator has actuated the hand lever (L), to its floating position (locked in front position) which moves the slide to change the hole pattern between the connections in the valve. The hole pattern is adapted for the floating status. Both sides of the lifting cylinder (L1) is connected to each other and to the return line in the slide. I.e. no pressure can reach any side of the cylinder. No oil pressure affects the cylinder. The main part of the oil is flowing between the upper part and the lower part of the cylinder. A smaller part is flowing between the oil tank and the cylinder due to the displacement of the piston rod. See the arrows in the picture below.

In the floating position, the implement always rests against the ground with the same force (the weight of the implement) and follows the contours of the ground.

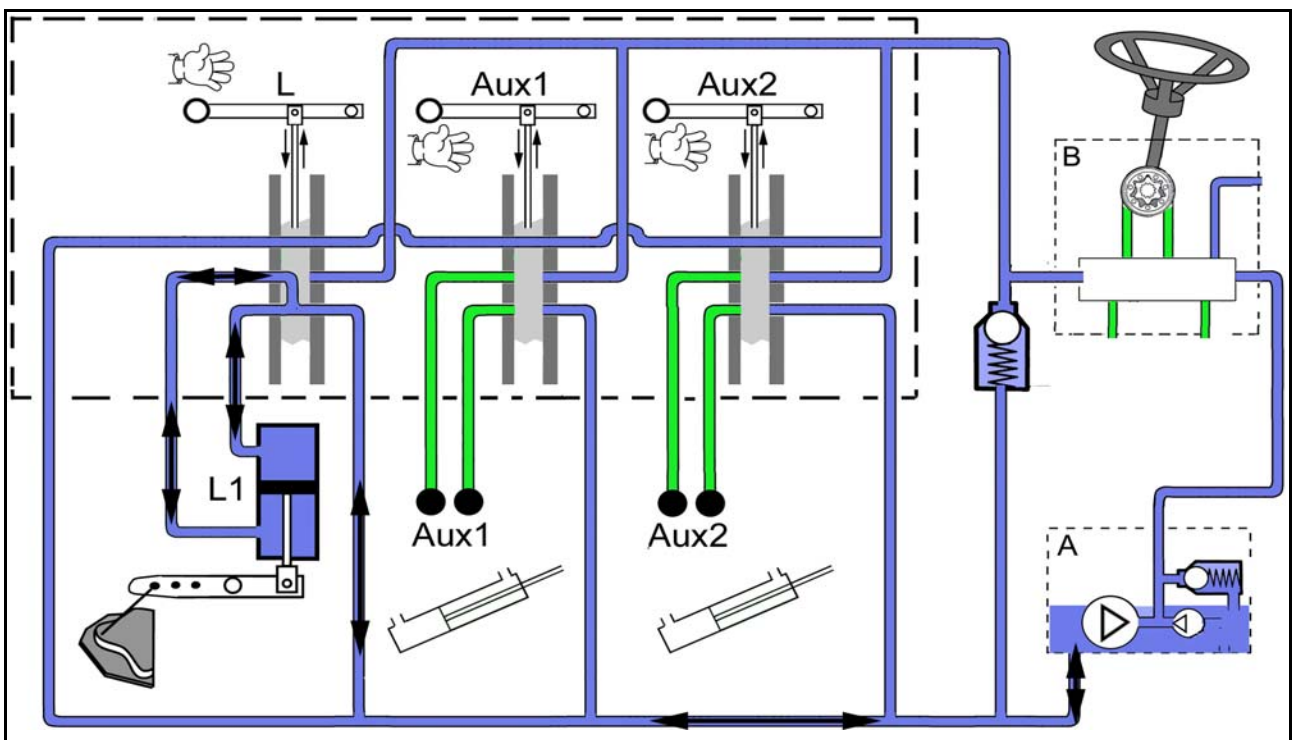

Edition	Manual	Chapter	Page
2014-12-09	Workshop Manual, GGP Park	4 Hydraulic system	19

## Hydraulic outputs Aux1 and Aux2

### Operation state:

- Motor is running.

The hydraulic outputs Aux1 and Aux2 have the same function. The purpose of the outlets is to make some adjustments/settings in a connected implement.

The outputs can be set in the following three positions:

- Oil flow in direction A. E.g. the cutting height in a connected cutting deck is raised.
- Oil flow in direction B. E.g. the cutting height in a connected cutting deck is lowered.
- Oil flow is shut (Off). E.g. the cutting height in a connected cutting deck is locked.

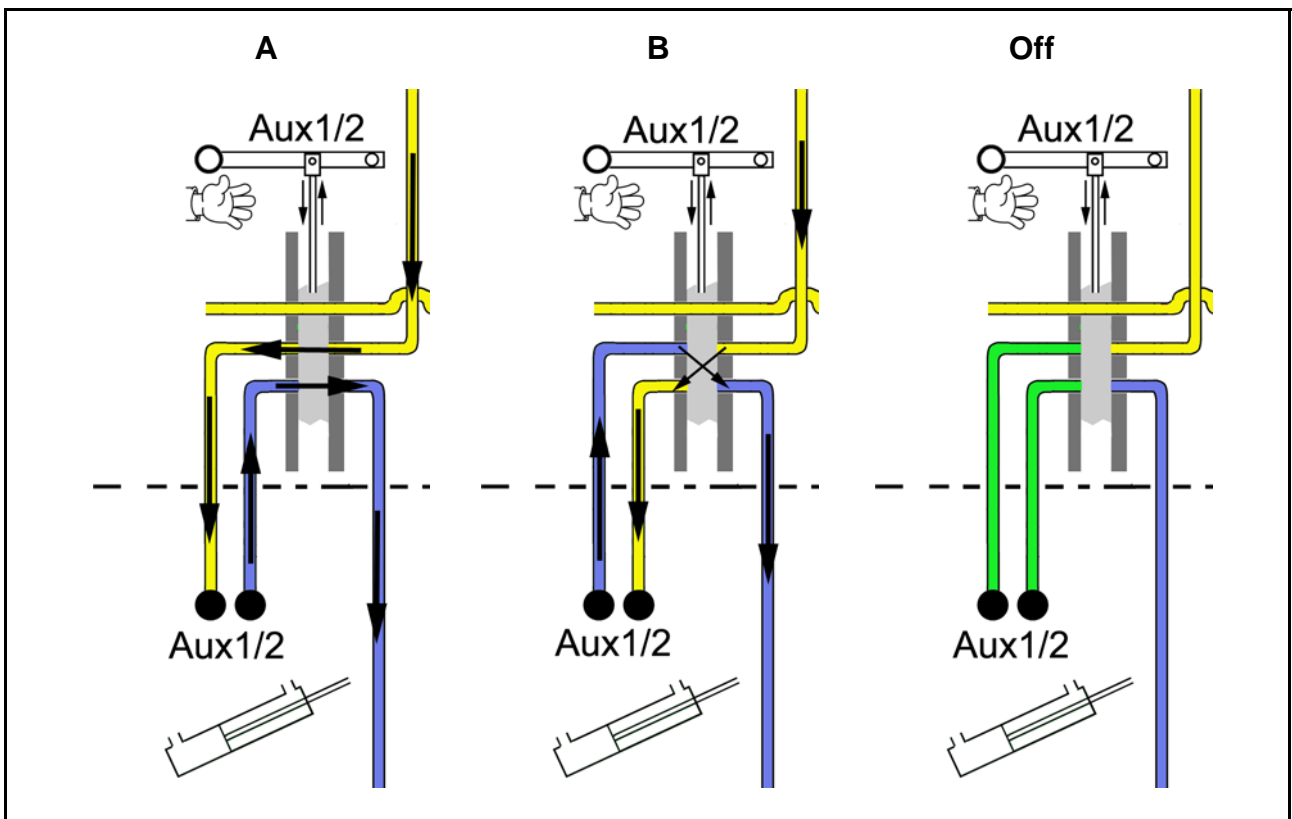

Edition	Manual	Chapter	Page
2014-12-09	Workshop Manual, GGP Park	4 Hydraulic system	20

## 4.6 Trouble shooting



### Warning!

Hydraulic oil under pressure can be very dangerous if hoses, lines or other distribution parts are leaking. To avoid personal injuries, always wear protection gloves and protection goggles during works with the hydraulic system.

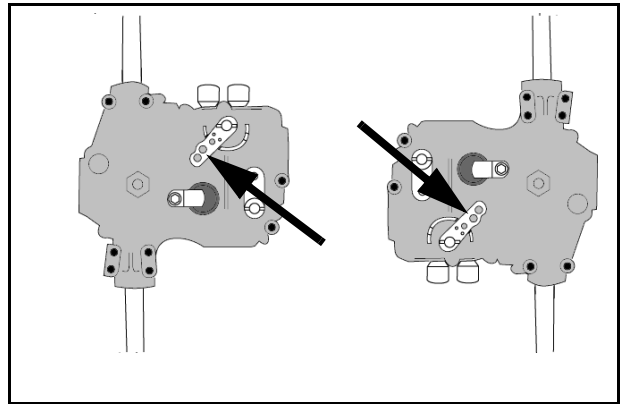

### 4.6.1 Drive system

Before the trouble shooting takes place, it is provided that the following states are fulfilled:

- The axle by-pass valves are in drive position. See the figure..
- The clutch release levers shall be in the drive position. See the figures.
- Oil level in the oil tank as desired.
- No air in the hydraulic oil.

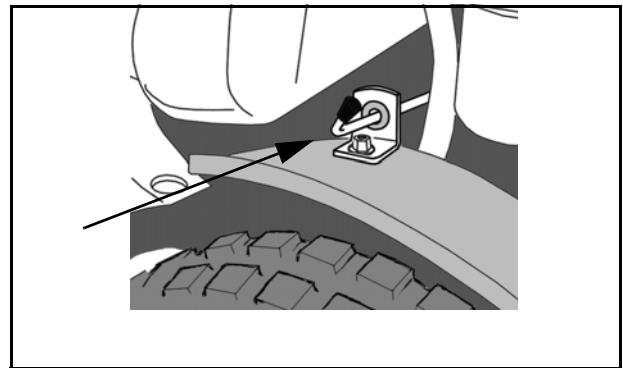



Edition	Manual	Chapter	Page
2014-12-09	Workshop Manual, GGP Park	4 Hydraulic system	21

Symptom	Fault	Measure
The machine drives forwards but not backwards.	Front by-pass valve open.	Close the by-pass valve.
	Big leakage in the front axle drive.	Replace the front axle drive.
The machine drives backwards but not forwards.	Rear by-pass valve open.	Close the by-pass valve.
	Big leakage in the rear axle drive.	Replace the rear axle drive.
Reduced speed forwards and possibly faster backwards.	Speed control cable housing is moved.	Adjust the cable housing.
Reduced speed and uneven drive.	The suction filter (5) is clogged.	Clean the filter.
The front wheels don't drive.	One of the axle keys is broken.	Replace the actual key.
The rear wheels don't drive.	One of the axle keys is broken.	Replace the actual key.
Reduced or no speed.	The belt between motor and pump is slipping. Check if the fan and pulley at the pump rotate.	<u>Worn belt</u> Replace the belt. <u>Maladjusted clutch wire</u> Adjust the wire.
	Big leakage in the hydraulic pump.	Replace the hydraulic pump.
	The pressure relieve valve (1,5-2,5 bar) for the charge pump defective.	Check the valve and its spring. See "Charge pump" at page 6.
	Speed control cable loose or mowed.	Repair/adjust the speed control cable.
Bad driving forwards	Bad efficiency rear drive.	Replace the rear axle drive.
Bad driving backwards	Bad efficiency front drive.	Replace the front axle drive.

Edition	Manual	Chapter	Page
2014-12-09	Workshop Manual, GGP Park	4 Hydraulic system	22

## 4.7 Auxiliary hydraulic

### Warning!



Hydraulic oil under pressure can be very dangerous if hoses, lines or other distribution parts are leaking. To avoid personal injuries, always wear protection gloves and protection goggles during works with the hydraulic system.

### Warning!



Before starting the motor, place the machine outdoors or install an extraction device for the exhaust fumes. Otherwise the personnel will be poisoned.

This section describes the trouble shooting procedures in absence of proper functions at the hydraulic assisted steering and implement lifter. It also describes the correction measures in each actual case. When following the trouble shooting table, it is provided that the following states are fulfilled:

- Parking brake not activated.
- A new filter installed
- Motor is running in full speed.
- The oil reservoir level shall be adjusted.
- The machine is warmed up during at least 10 minutes to a oil temperature of at least 50°C.

The pressure (about 35 bar) in the auxiliary hydraulic is divided between the implement lifter and the steering torque valve. If anyone of these gets more pressure, the other must gets less. See the diagram.

The adjustment screw in the figure below is accessible after that the instrument covers are dismantled. See "Instrument covers" at page 10 in section "2 Chassis".

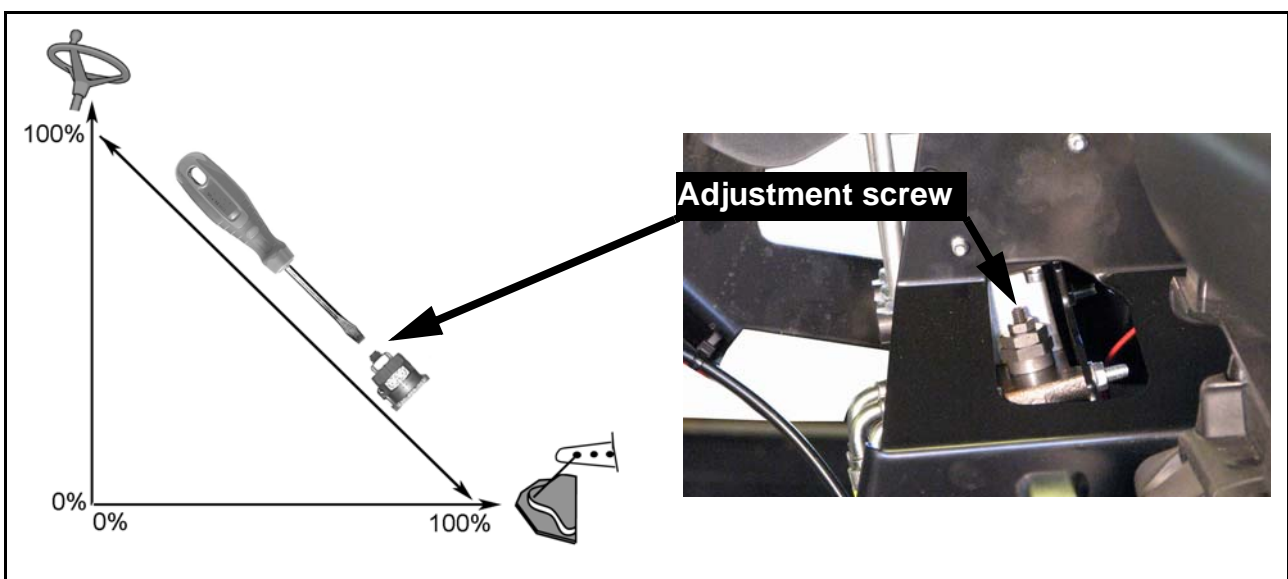

Edition	Manual	Chapter	Page
2014-12-09	Workshop Manual, GGP Park	4 Hydraulic system	23

## Adjustment



### Warning!

**Never screw out the adjustment screw too far, this will cause lost of steering capacity.**

**After adjustment; Always check the steering capacity with the implement lifter working against its stop.**

Adjust the pressure (yellow line) by loosening the counter nut and rotate the adjustment screw.

Turn right (against bottom) to increase the lifting capacity and to decrease the steering ability.

Turn left (up) to decrease the lifting capacity and to increase the steering ability.

Lock the counter nut after the adjustment is finished.

## Adjustment procedure

1. The lifting capacity is set to about 1500 N / 150 kg at the factory. Measure the force and adjust if necessary..

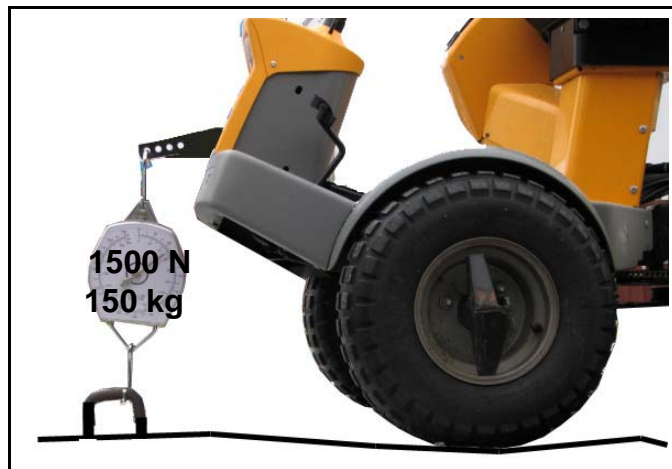

2. Drive the machine and test the steering ability.

If the steering is comfortable, the adjustment is OK.

If the steering not is comfortable, decrease the lifting ability.

If it is possible to reach an adjustment, where both the heaviest deck used can be lifted, and the steering feels comfortable, the adjustment is OK. If not, see below:

If the steering is comfortable when the screw is in its upper position and the lifting capacity is OK when the screw is in its lower position, replace the charge pump in the HST.

If the steering is impossible to get comfortable even when the screw is in its upper position and the lifting capacity is OK when the screw is in its lower position, replace the steering valve.

Edition	Manual	Chapter	Page
2014-12-09	Workshop Manual, GGP Park	4 Hydraulic system	24

## 4.8 Change of transmission oil

The oil and the filter in the hydraulic power transmission must be checked/adjusted or replaced at intervals according to the table below.

Action	1st time	Then at interval
	Hours of operation	
Check – adjusting level.	-	50
Changing oil. Replace filter in the hydraulic circuit	5	200

Oil type: Synthetic oil 5W-50.

Oil volume at change: approx. 4.7 litres.

### Check – adjustment

1. Place the machine on a flat surface.
2. Read off the oil level in the reservoir. See the figure. The level should be level with the line.
3. If necessary, top up with more oil.

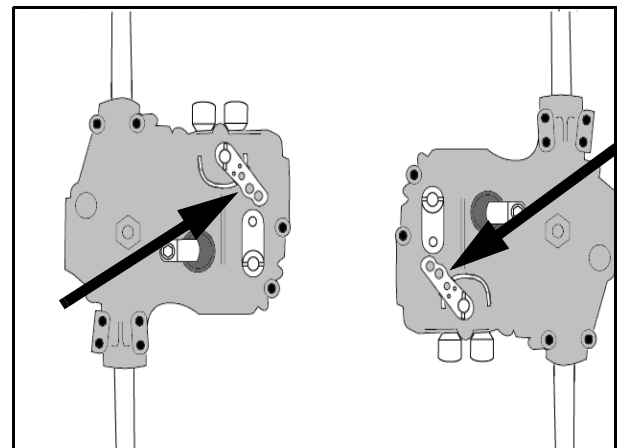
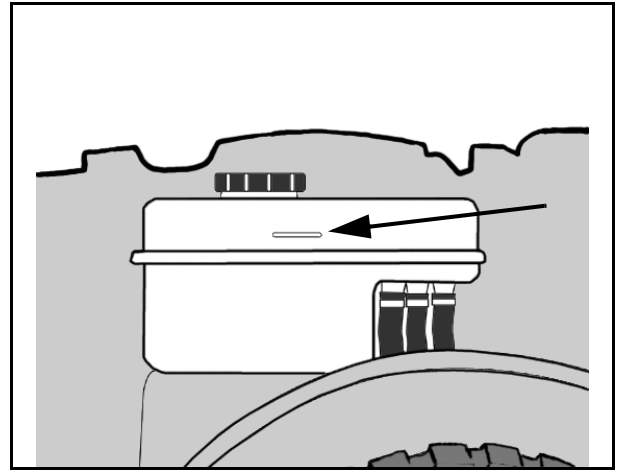

### Draining

1. Operate the machine at varying speeds for 10-20 minutes in order to warm up the transmission oil.
2. Open the drive shafts' valves in accordance with the figure.
3. Place one collection trough under the rear axle and one under the front axle.
4. Remove 2 drainage plugs from each axle. Use a 12 mm socket wrench. See the figure.
5. Remove the filler cap from the oil tank.

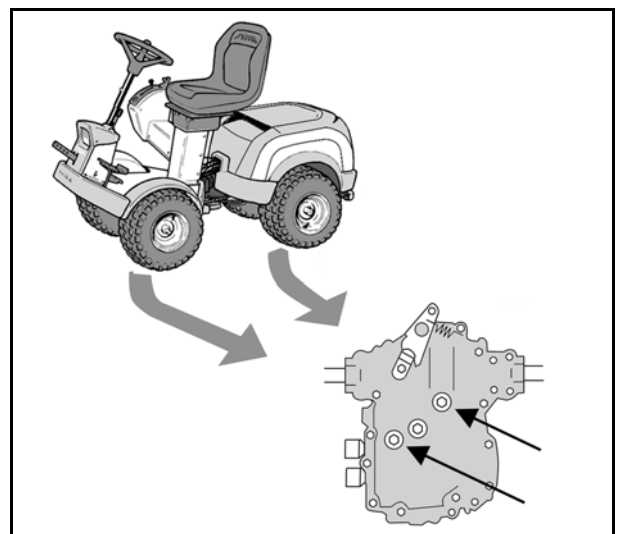

Edition	Manual	Chapter	Page
2014-12-09	Workshop Manual, GGP Park	4 Hydraulic system	25

6. Clean the area around the hydraulic circuit's filter and dismantle the filter. See the figure.
7. Allow all the oil to run out into the collection trough.
8. Draw out the oil from the deeper section of the reservoir using an oil extractor. See the figure.
9. Hand in the oil for disposal in accordance with local provisions.

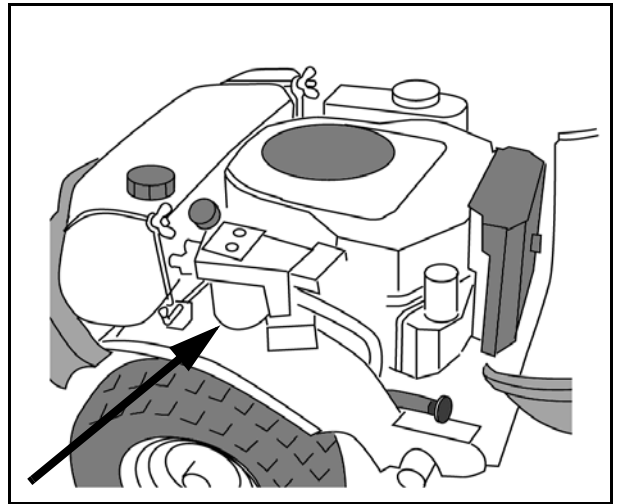

### Filling with help of the engine

1. Check that the gaskets on the 4 drainage plugs are intact. Reinstall the plugs. Tightening torque: 15-17 Nm.
2. Moisten the new filter's gasket with oil and install the filter.
3. Fill the oil reservoir with the new oil.
4. Check that the clutch release lever (R) is in the outer position (drive position).



**If the engine is to be run indoors, an exhaust extraction device must be connected to the engine's exhaust pipe.**

5. Prepare a suitable vessel with the new oil.

**NOTE! The oil is sucked into the system very quickly. The reservoir must always be kept topped up. Under no circumstances may air be sucked in.**

6. Fill the oil reservoir with new oil.
7. Start the engine and allow it to idle. Gradually top up the oil in the reservoir so that the level constantly reaches the mark.

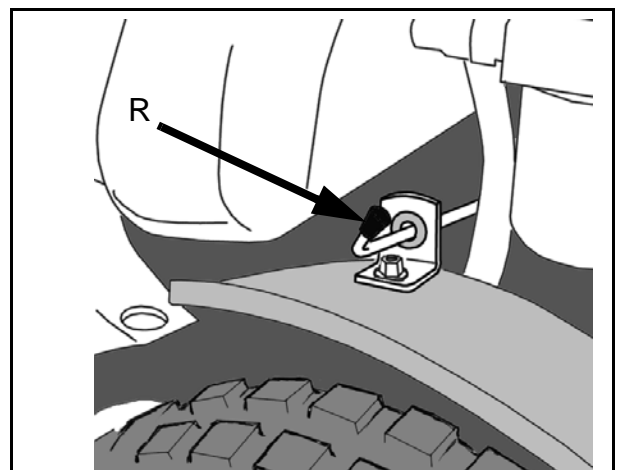
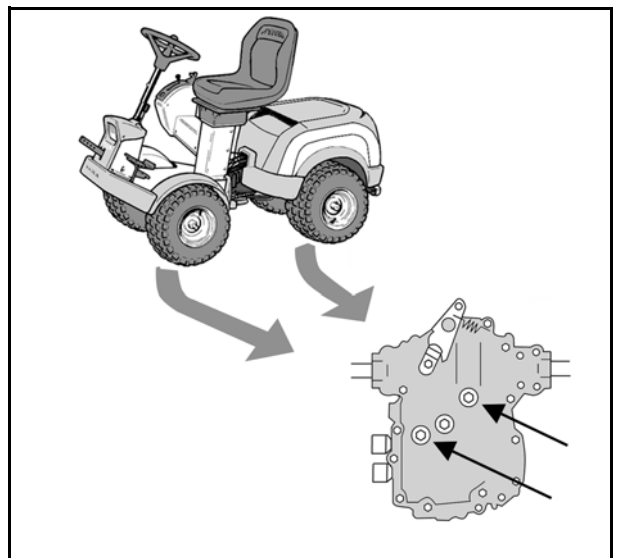

Edition	Manual	Chapter	Page
2014-12-09	Workshop Manual, GGP Park	4 Hydraulic system	26

8. Reinstall the oil filler cap and close the engine casing.
9. Reset the drive shafts' valves in accordance with the figure.
10. Drive the machine 8-10 metres forwards and 8-10 metres backwards. Apply full steering in both directions at the same time.
11. If the machine has a hydraulic implement lifter, raise and lower the lifter 3-4 times.
12. Adjust the oil level in the reservoir.

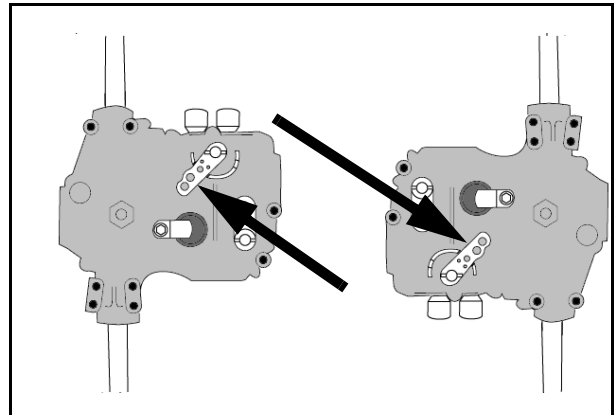

### Filling with external pump

1. Check that the gaskets on the 4 drainage plugs are intact. Reinstall the plugs. Tightening torque: 15-17 Nm.
2. Moisten the new filter's gasket with oil and install the filter.
3. The drive shafts' valves shall be opened in accordance with the figure.

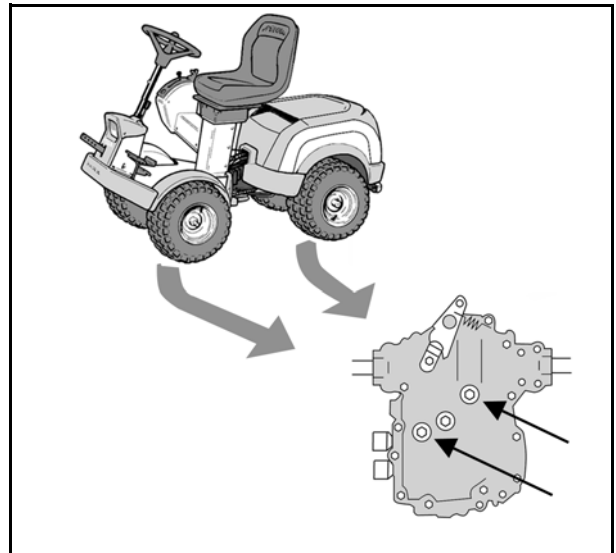

4. Check that the clutch release lever (R) is in the outer position (drive position).

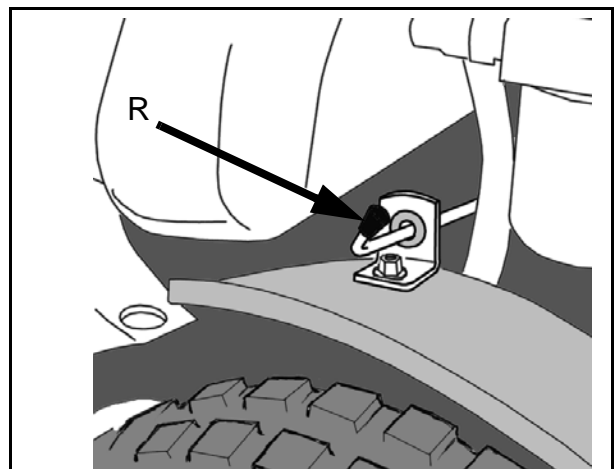



Edition	Manual	Chapter	Page
2014-12-09	Workshop Manual, GGP Park	4 Hydraulic system	27

5. Connect a pump device to the nipple in the figure and pump in the new oil into the system.
6. Stop pumping when the oil reservoir is nearly full.
7. Start the engine and allow it to idle. Gradually top up the oil in the reservoir so that the level constantly reaches the mark.
8. Fill the oil reservoir with the new oil.
9. Check that the clutch release lever (R) is in the outer position (drive position).

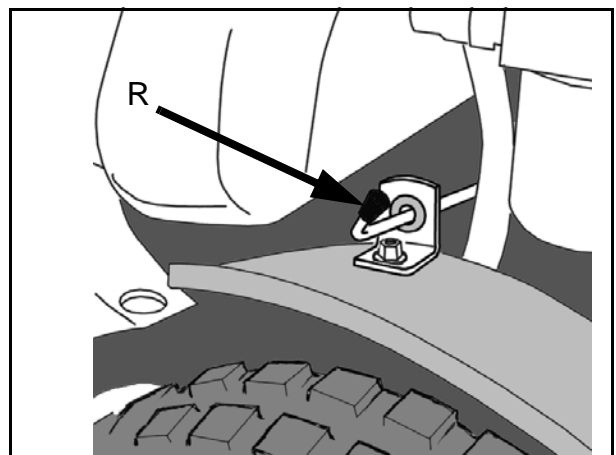
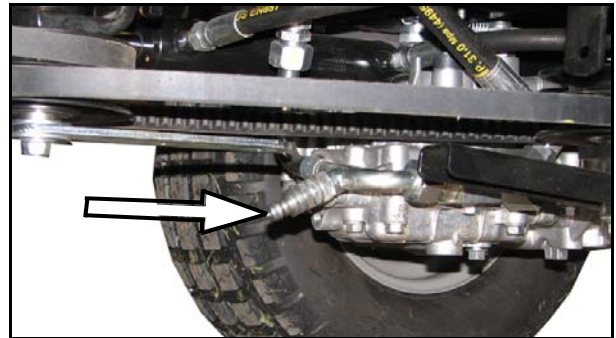

10. Reset the drive shafts' valves in accordance with the figure.
11. Drive the machine 8-10 metres forwards and 8-10 metres backwards. Apply full steering in both directions at the same time.
12. If the machine has a hydraulic implement lifter, raise and lower the lifter 3-4 times.
13. Adjust the oil level in the reservoir.

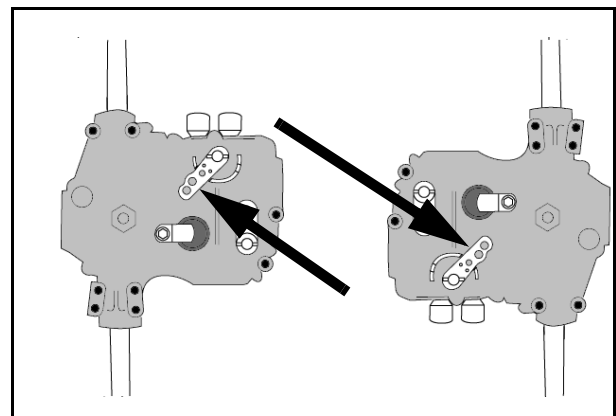

Edition	Manual	Chapter	Page
2014-12-09	Workshop Manual, GGP Park	5 Belts	1

## 5 Belts

### Contents in this chapter

<b>5.1 Belt theory.....</b>	<b>2</b>
5.1.1 Why it is so important to use original belts from the retail dealer?.....	2
<b>5.2 Belt locations.....</b>	<b>4</b>
<b>5.3 Replacement of belts .....</b>	<b>5</b>
5.3.1 Belt A.....	5
5.3.2 Belt B.....	5
5.3.3 Belt C .....	5
<b>5.4 Belt D.....</b>	<b>6</b>

### General

All mechanical power, delivered by the motor, is conducted to the different power consumers by a belt system. The maximum tension of each belt is regulated by a spring loaded belt tensioner.

This chapter gives a brief description of the belt system and describes briefly replacements of the belts.

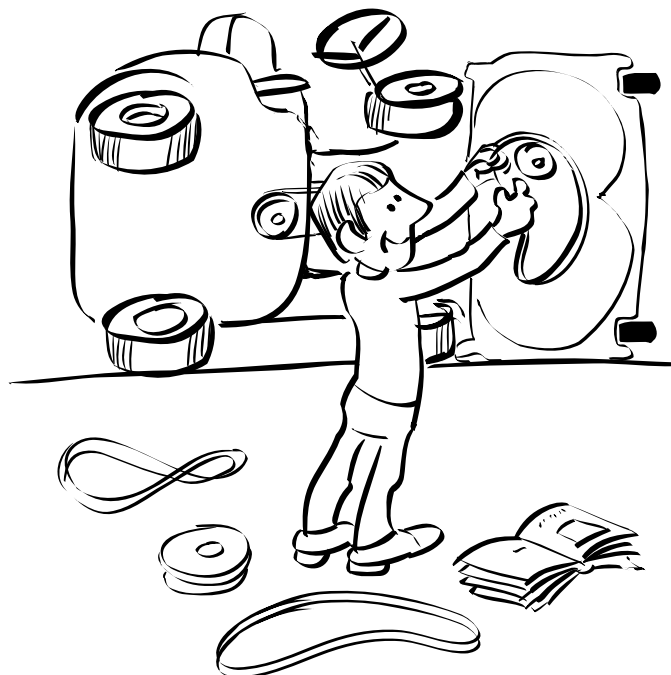

Edition	Manual	Chapter	Page
2014-12-09	Workshop Manual, GGP Park	5 Belts	2

## 5.1 Belt theory



### 5.1.1 Why it is so important to use original belts from the retail dealer?

The table below shows the demands on normal commercial grade belts compared to demands on original spare parts belts from the retail dealer. The later are designed and manufactured in close connection between the subcontractor and the rider manufacturer.

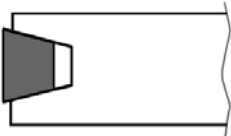
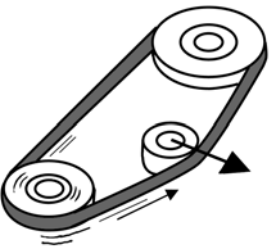
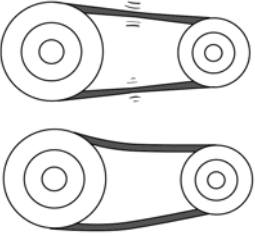
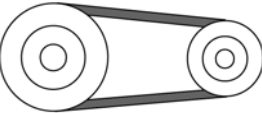
The table is intended to display the importance to use the original belts.

Case	Commercial grade belts	Original spare parts belts	Remarks
Fitness to pulleys. 	The belt shall rest with its angled sides against the pulleys. There must be a space between belt and pulley bottom.	The belt shall rest with its angled sides against the pulleys. There must be a space between belt and pulley bottom.	Same demands. Original belts guarantee that the belt fits against the pulleys.
Acceleration. 	The belt follows the motor rpm in a continuous acceleration up to full speed.	Some belts shall engage to the pulleys with the motor running in full speed, which gives an excessive generation of heat.	Common belts are made of natural rubber, which can resist temperatures up to 70° only.  Original belts are made of chloroprene rubber, which can resist temperatures up to 90°
Length 	Manufactured in standard lengths in steps..	Manufactured in predefined lengths to fit between the pulleys.. 	The distance between the pulleys is fix. The belt tensioner gives the original belt an optimal tension.

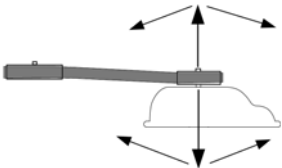
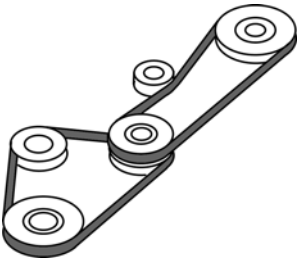
Edition	Manual	Chapter	Page
2014-12-09	Workshop Manual, GGP Park	5 Belts	3

Case	Commercial grade belts	Original spare parts belts	Remarks
Floating pulley at the implement. 	Designed to transmit power between aligned, parallel and fixed pulleys.	The original PTO belt is designed to operate, even if the pulleys are moving up and down and are tilting at the same time	The implement follows the ground which involves that its pulley is constant moving.  To resist the excessive operating conditions, the original belts are made of fibre reinforced rubber.
Bending in two directions 	Designed to bend around pulleys in one direction only	Most of the belts at the machine have tension rollers, actuating from the outside of the belt. This means the the belt has to bend both inwards and outwards during the operation.	All original belts which operate with tension rollers actuating from the outside have reinforcements. The reinforcement is special designed for the actual case.
Noise 	Manufactured without any special respect to the actual case.	The original belts are carefully selected to give the lowest noise increment to the machine during operation.	Depending on the function of the belt, any of the following belt types are itemised: <ul style="list-style-type: none"> <li>• Wrapped</li> <li>• Non-friction</li> <li>• Raw-edge</li> </ul>

Edition	Manual	Chapter	Page
2014-12-09	Workshop Manual, GGP Park	5 Belts	4

## 5.2 Belt locations

1. Pulley at the work equipment.
  2. Tension pulley.
  3. Pulley (double) above the front shaft.
  4. Tension pulley.
  5. Pulley (double) at the articulation point.
  6. Tension pulley.
  7. Drive pulleys at the motor shaft.
  8. Tension pulley.
  9. HST pulley.
- A. PTO belt.  
 B. Belt, articulation point - forwards.  
 C. Belt, motor-articulation point.  
 D. Belt, motor - HST.

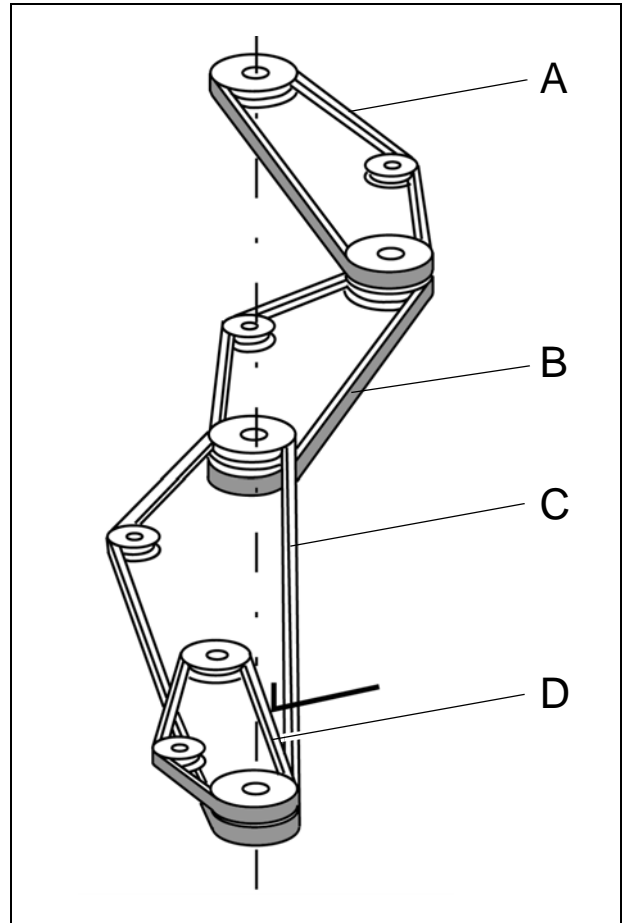

Edition	Manual	Chapter	Page
2014-12-09	Workshop Manual, GGP Park	5 Belts	5

## 5.3 Replacement of belts

### 5.3.1 Belt A

Belt A belongs to the work equipment and is not described here. The description is included in the respective work equipment manual.

### 5.3.2 Belt B

1. Dismantle the tensioning arm with its pulley. See parts of the instruction in "Covers around the articulating point" at page 6 in section 2.
2. Work off the belt and assemble in the reverse order.

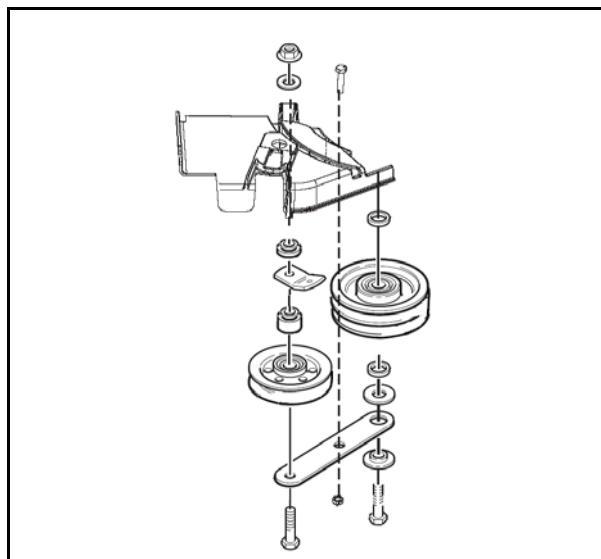

### 5.3.3 Belt C

1. Remove belt A and B. See above.
2. Remove the tension pulley by using a 15 mm and a 17 mm spanner. See the figure.



3. Remove the magnetic clutch cables.



#### **Warning!**

**The magnetic clutch is heavy. Be careful when removing.**

4. Screw out the magnetic clutch screw and pull down the clutch.
5. Replace the belt and reassemble in the reverse order.

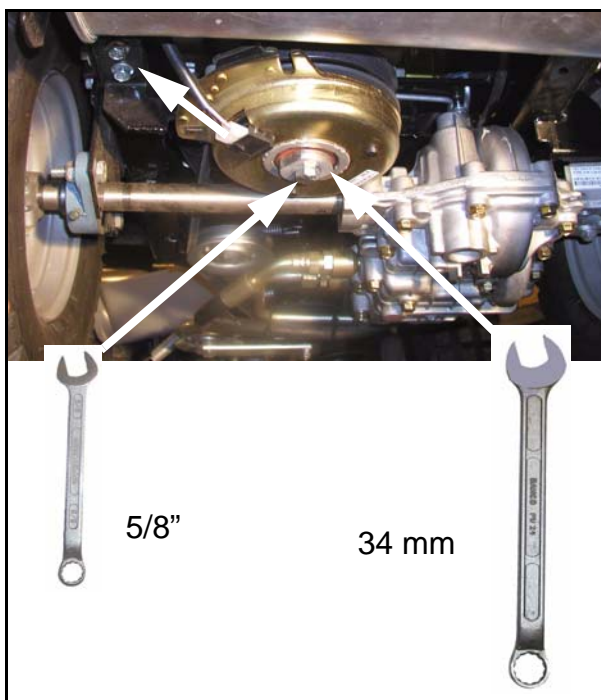



Edition	Manual	Chapter	Page
2014-12-09	Workshop Manual, GGP Park	5 Belts	6

- ! Note!  
Check that the dog fits in the hole in the magnetic clutch. See the figure.

Tightening torque  
magnetic clutch screw: **50 Nm**.

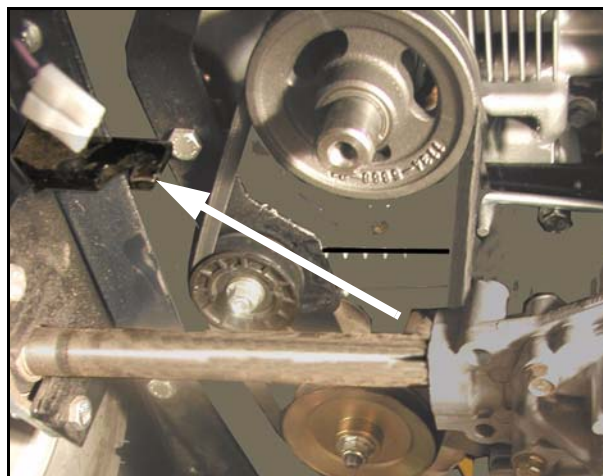

### 5.3.4 Belt D

1. Remove belt A, B and C. See above.

- ! **Warning!**  
**Do not bend the lever when loosening or tightening the pulley nut.**

2. Remove the tension pulley by using two 15 mm wrenches.
3. Replace the belt and reassemble in the reverse order.

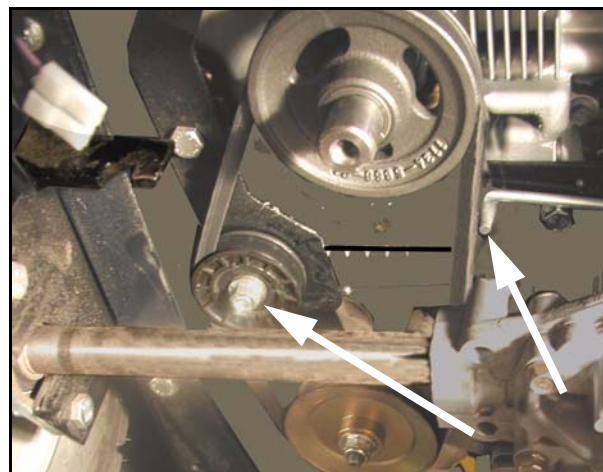

- ! Note!  
The belt guide shall support the belt from its outside.

Edition	Manual	Chapter	Page
2014-12-09	Workshop Manual, GGP Park	6 Control wires	1

## 6 Control Wires

### Contents in this chapter

<b>6.1 Description</b> .....	<b>2</b>	<b>6.4 Choke wire</b> .....	<b>7</b>
<b>6.2 General measures</b> .....	<b>3</b>	6.4.1 Dismantling .....	7
6.2.1 Elbow links .....	3	6.4.2 Assembly .....	8
<b>6.3 Throttle wire</b> .....	<b>5</b>	6.4.3 Adjustment.....	8
6.3.1 Dismantling.....	5	<b>6.5 HST control wire</b> .....	<b>9</b>
6.3.2 Assembly .....	6	6.5.1 Dismantling .....	9
6.3.3 Adjustment .....	6	6.5.2 Assembly .....	9
		6.5.3 Adjustment.....	10

### General

All the manoeuvring functions are incorporated on the control panel. This is an excellent solution in terms of ergonomics and comfort. It also simplifies the service work since all the controls and adjustments can be accessed in one place.

All mechanical control movements from the operator to the respective device on the machine are conducted by wires and in some cases with rods.

This chapter gives a brief description of the equipments and describes their repair and replacements.



Edition	Manual	Chapter	Page
2014-12-09	Workshop Manual, GGP Park	6 Control wires	2

## 6.1 Description

All wires consist of a wire and a conduit. In the wire ends one part, the wire or the conduit, is fastened to the body and the other part to a lever. The levers are connected to the operator control and to the controlled device.

The wires are also in most cases fitted with adjustments sleeves with locking nuts or angle links at one or both ends.

To transfer higher forces and both pushing and traction forces, rods are used, i.e. brakes, etc.

### Maintenance of wires:

Drop a little engine oil or lubricating spray in the ends of the control wires two or three times a year.

- A. Rod
- B. Wire with conduit
- C. Fastening to body
- D. Lever
- E. Spring
- F. Elbow link

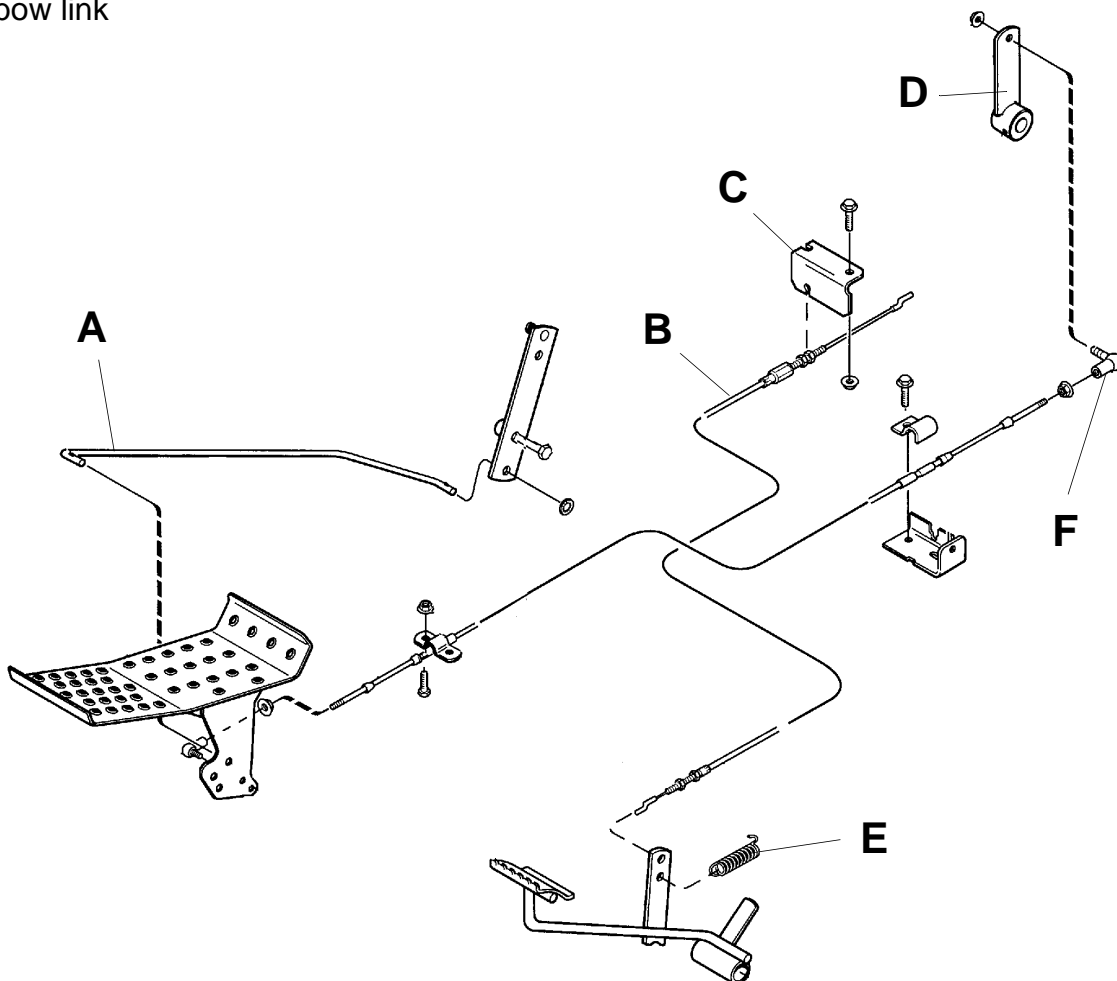

Edition	Manual	Chapter	Page
2014-12-09	Workshop Manual, GGP Park	6 Control wires	3

## 6.2 General measures

### 6.2.1 Elbow links

In many cases there are elbow links mounted at the wire ends. The elbow links have two functions as follows:

- To transmit the movement to/from the actual lever.
- For wire adjustment purpose. The wire tension is adjusted by screwing the link on/off the threaded rod at the wire.

**! Note!**  
At the adjustment, at least 5 threads shall be engaged.

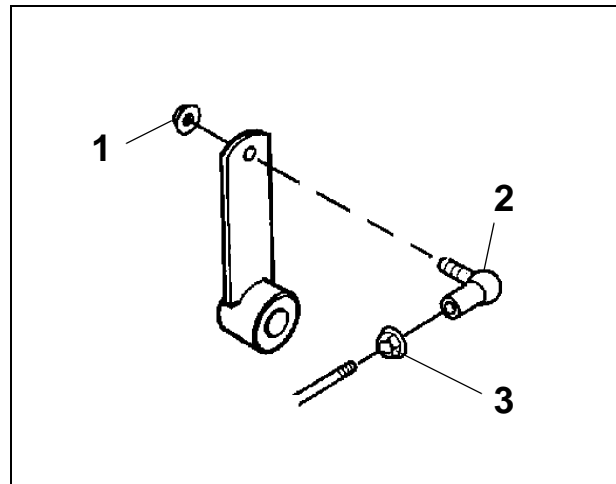

#### To change an elbow link

1. Loosen the nut (3) with a 8 mm wrench.
2. Remove the nut (1) with a 8 mm wrench. Hold the elbow stud with a 7 mm wrench.
3. Screw the elbow link off the rod.
4. The assembly is performed in the reverse order.
5. After the assembly, adjust the wire.



#### To apart an elbow link

1. Fold up the circlip (4) from the elbow link body.
2. Pull out the circlip.
3. Pry off the link body from the stud sphere by help of a screwdriver or similar.
4. The assembly is performed in the reverse order. The link body is pressed onto the sphere by help of a polygrip or similar.

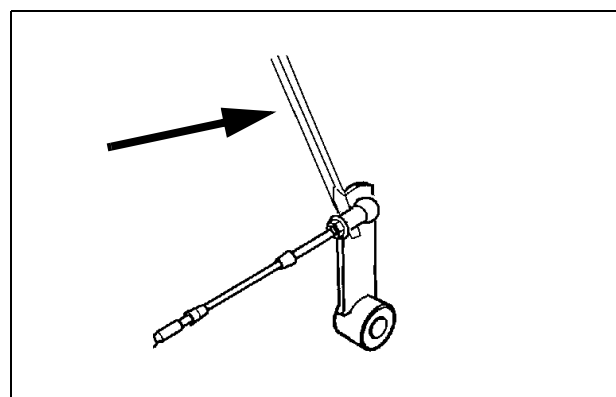

**! Note!**  
It is important that the circlip (4) is inserted in both holes in the elbow link body, otherwise the link will separate during operation.

Edition	Manual	Chapter	Page
2014-12-09	Workshop Manual, GGP Park	6 Control wires	4

## Adjustment

1. Loosen the nut (3) with a 8 mm wrench.
2. Apart the elbow link as described above.
3. Screw the link body in the desired direction on the wire stud. If necessary, move the nut (3) on the stud.
4. Check the adjustment result by pressing on the elbow link onto the sphere and without assembling the circlip.
5. After adjustment, assemble in the reverse order and tighten the nut (3) against the elbow link body.



### Note!

It is important that the circlip (4) is inserted in both holes in the elbow link body, otherwise the link will separate during operation.

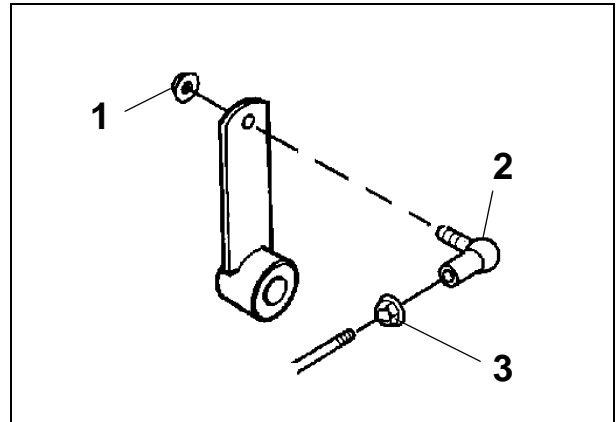

Edition	Manual	Chapter	Page
2014-12-09	Workshop Manual, GGP Park	6 Control wires	5

## 6.3 Throttle wire

### 6.3.1 Dismantling

1. Dismantle the upper and lower front engine covers. See “Front engine covers” at page 5 in “2 Chassis”.
2. Dismantle the outside instrument cover. See “Instrument covers” at page 10 in “2 Chassis”.
3. Cut the holding straps (A) and note their location for the assembly purpose.
4. Dismantle the lower instrument cover (B) by loosening its four screws.

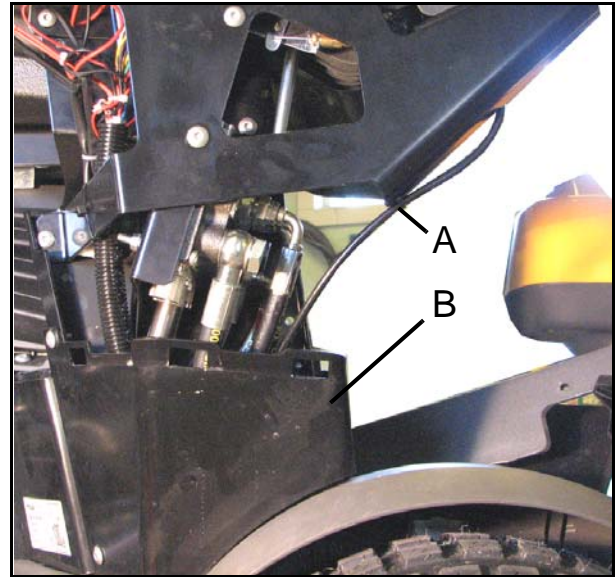

5. Loosen the nut at the rear of the engine and hook off the wire.

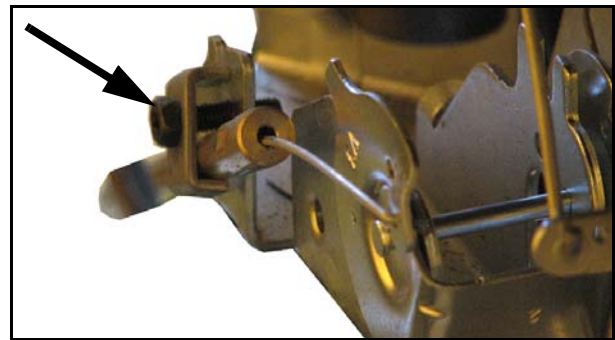

6. Push out the choke wire and the throttle wire from the holder at the articulating point.





Edition	Manual	Chapter	Page
2014-12-09	Workshop Manual, GGP Park	6 Control wires	6

7. Press out the front sleeve from its holder. Use a screwdriver.
8. Work the entire wire forwards and hook it off the throttle lever and take it out.

### 6.3.2 Assembly

1. Assemble the throttle wire in the reverse order.
2. Drop a few drops oil at the wire ends and move the wire some strokes in its housing.
3. The front sleeve can be forced into place with help of a polygrip pliers.
4. Install new holding straps where the previous was cut.



### 6.3.3 Adjustment

1. Tighten the sleeve holding screw (A) very light.
2. Set the throttle lever in its idling position.
3. Start the engine and adjust the sleeve until the engine rpm shall start to increase.
4. Tighten the sleeve screw in a position where the engine rpm still is idling.

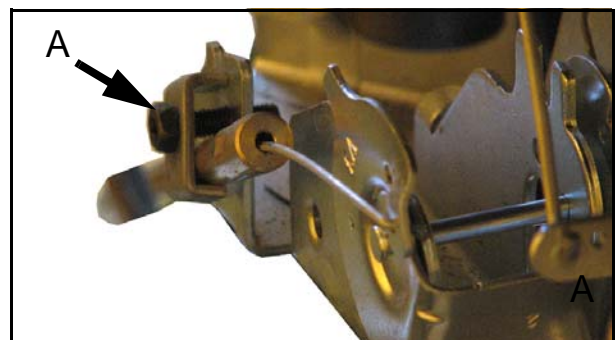

Edition	Manual	Chapter	Page
2014-12-09	Workshop Manual, GGP Park	6 Control wires	7

## 6.4 Choke wire

### 6.4.1 Dismantling

1. Dismantle the upper and lower front engine covers. See "Front engine covers" at page 5 in "2 Chassis".
2. Dismantle the outside instrument cover. See "Instrument covers" at page 10 in "2 Chassis".
3. Cut the holding straps (A) and note their location for the assembly purpose.
4. Dismantle the lower instrument cover (B) by loosening its four screws.
5. Loosen the nut at the rear of the engine and hook off the wire.

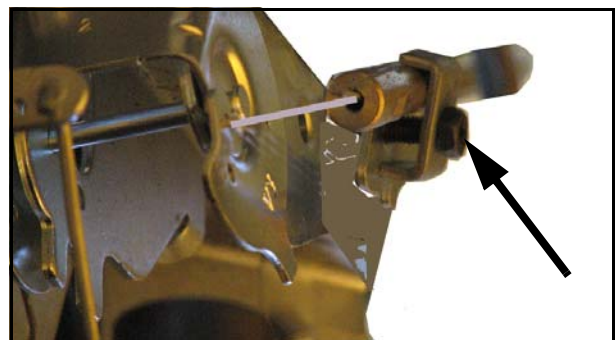
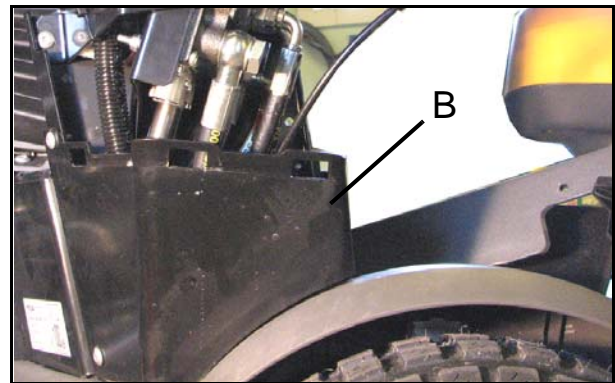

6. Push out the choke wire wire from the holder at the articulating point.

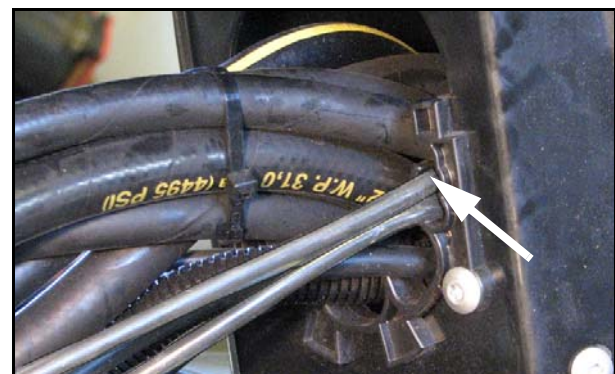

7. Loosen the knob nut, located under the panel.
8. Work the entire wire forwards and take it out through the panel mounting hole.

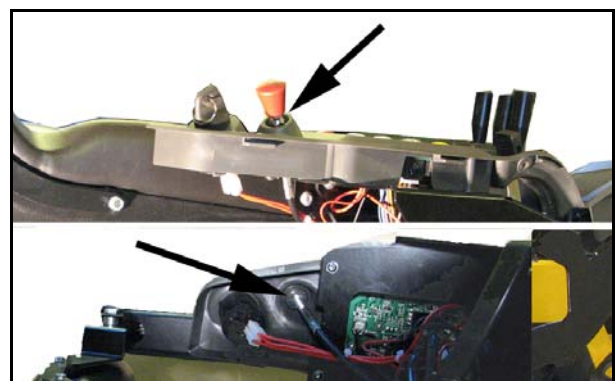

Edition	Manual	Chapter	Page
2014-12-09	Workshop Manual, GGP Park	6 Control wires	8

## 6.4.2 Assembly

1. Assemble the choke wire in the reverse order.
2. Drop a few drops oil at the wire ends and move the wire some strokes in its housing.
3. Install new holding straps where the previous was cut.

## 6.4.3 Adjustment

1. Tighten the sleeve holding screw (A) very light.
2. Actuate the choke knob and check that the engine choke lever can reach its end positions.

Check also that the choke knob can be forced fully into its end down position.

3. Tighten the sleeve screw (A).

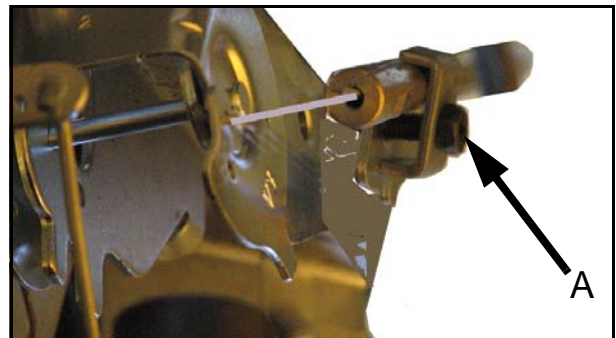

Edition	Manual	Chapter	Page
2014-12-09	Workshop Manual, GGP Park	6 Control wires	9

## 6.5 HST control wire

### 6.5.1 Dismantling

1. Dismantle the upper and lower front engine covers. See “Front engine covers” at page 5 in “2 Chassis”.
2. Loosen the elbow links front and rear from their levers. See “Elbow links” at page 3.
3. To make it easier to take out the wire, unscrew the rear elbow link from the rod.
4. Loosen the conduit attachments front and rear and draw out the wire forwards.

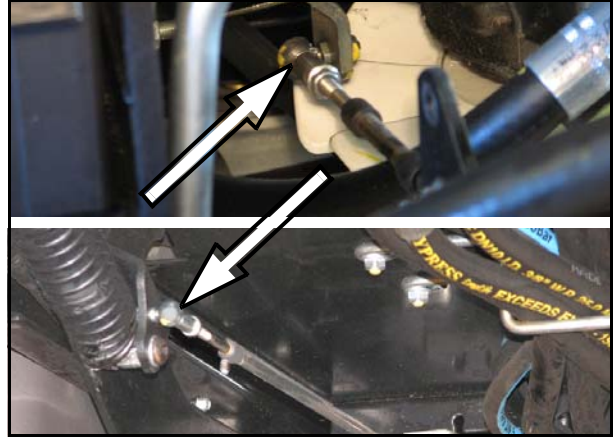

### 6.5.2 Assembly

1. Fit the new wire in the same location as the old one.
2. Check the elbow links for damage or wear. Replace with new links if necessary. Fit the elbow links with their locking nuts at the wire ends. See “Elbow links” at page 3. The links shall be screwed onto the wire ends about 1 cm.
3. Fit the new wire in the same location as the old one.

**!** Note!  
The longer rod tube shall be located forwards.

4. Fit the front and rear clamps. Make sure that the dogs at the clamps fit in the grooves in the wire cover. Both front and rear. See the figure.
5. Fit the elbow links to the levers.
6. Adjust the control wire as described below.

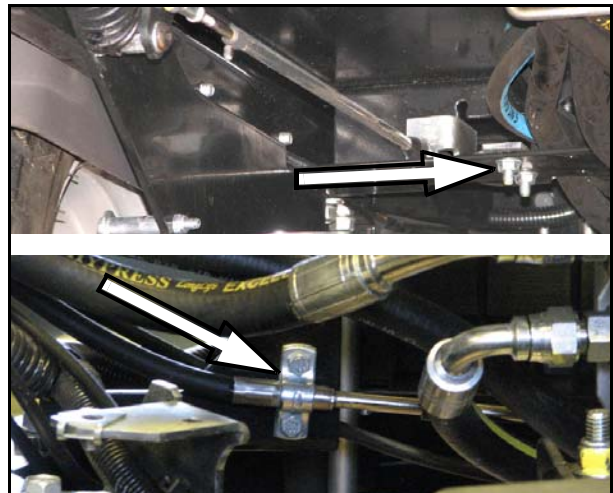



Edition	Manual	Chapter	Page
2014-12-09	Workshop Manual, GGP Park	6 Control wires	10

### 6.5.3 Adjustment

The length of the wire is adjusted by screwing the elbow links in the desired direction. Perform the adjustment at both links. The links shall be screwed onto the wire about the same amount. See “Elbow links” at page 3.

1. Set the rear stop screw in its lowest position.
2. Block up the pedal with a piece of wood or similar until the pedal rests against its rear stop. If the pedal doesn't reach its rear stop, adjust the elbow links.
3. Check that the pump lever has fully reach its stop position. If not, adjust the elbow links.
4. Block up the pedal with a piece of wood or similar until the pedal rests against its front stop. If the pedal doesn't reach its front stop, adjust the stop upwards.
5. Check that the pump lever has fully reach its stop position. If not, adjust the elbow links.

When the control wire is properly adjusted, the following conditions shall be fulfilled:

- Both elbow links shall be screwed onto the wire ends about the same amount.
- The pedal shall easily reach its rear stop (moved backwards). Simultaneously shall the pump lever reach its stop position.
- The pedal shall easily reach its front stop (moved forwards). Simultaneously shall the pump lever reach its stop position.



#### Warning!

If the pump lever reach its stop and the pedal not, abnormal push/pull forces will occur in the wire. This will limit the wire durability.

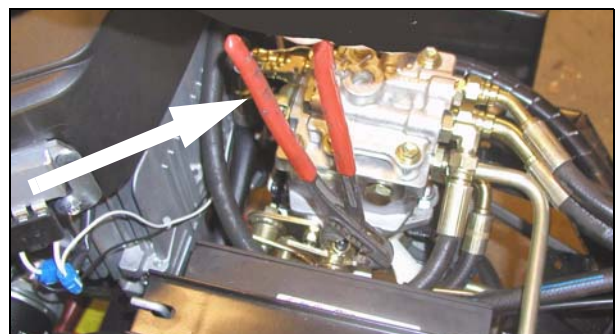
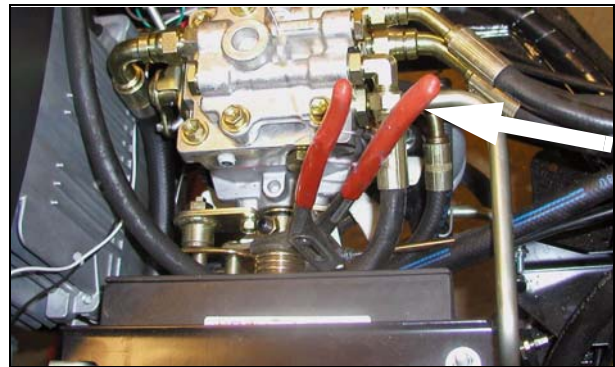

Edition	Manual	Chapter	Page
2014-12-09	Workshop Manual, GGP Park	7 Electrical System	1

## 7 Electrical System

### Contents in this chapter

<b>7.1 Description</b> .....	<b>2</b>
<b>7.2 Trouble Shooting</b> .....	<b>3</b>
7.2.1 Electric diagrams.....	6
<b>7.3 Repair and replacements</b> .....	<b>8</b>
7.3.1 Display/card device .....	8
7.3.2 Connections .....	9

### General

The electrical system has two main duties, to maintain the machine safety and to make the different functions easy to handle.

The main part of this chapter consists of trouble shooting of the electrical system to isolate faults and to give information about corrective measures. The electrical system is also described. There are also given instructions about general repair and replacement procedures.







Edition	Manual	Chapter	Page
2014-12-09	Workshop Manual, GGP Park	7 Electrical System	3

## 7.2 Trouble Shooting



### Warning!

**Do not wear rings, metallic bracelet, chain round the neck or similar metal objects when working with the electrical system. It can cause short-circuit, burns and fire.**

This section describes the trouble shooting procedures in absence of an electrical function. It also describes the correction measures in each actual case. When following the trouble shooting tables, it is provided that the following states are fulfilled:



- All fuses are checked and, if necessary replaced.
- The battery shall be charged.
- All harnesses are OK.
- All connectors are OK.
- The requirements for the actual measure shall be fulfilled. E.g. if it is advised to perform a start attempt, the operator shall sit down on the seat, press the brake pedal and the power take off shall be in disengaged position.

When following the trouble shooting table, it is in normal cases assumed that conductors and connectors to conductors are OK. However, in some cases, after a long period of use or in case of mechanical damages, the cables at the articulating point can be damaged.

The trouble shooting do not need any complicated measurements, checks or other logic steps to isolate the fault. The actions to be taken are listed with the most probable fault first. That means, if not the first action helps, then try with the next one. Continue thus until the fault is repaired.

Faults related to the safety system are located first in the tables and marked with .

Edition	Manual	Chapter	Page
2014-12-09	Workshop Manual, GGP Park	7 Electrical System	4

Fault	Cause/Alternative	Action
 Start attempt with: Operator not sitting in seat. Brake pedal pressed.	The engine can start	<ol style="list-style-type: none"> <li>1. Adjust or replace the seat switch.</li> <li>2. Replace the display/card device.</li> </ol>
 Start attempt with: Operator sitting in seat. Brake pedal not pressed.	The engine can start	<ol style="list-style-type: none"> <li>1. Adjust or replace the brake pedal switch.</li> <li>2. Replace the display/card device.</li> </ol>
 Engine running. PTO magnetic clutch activated. and the operator rises from the seat.	The engine shall stop	<ol style="list-style-type: none"> <li>1. Adjust or replace the seat switch</li> <li>2. Replace the display/card device.</li> </ol>
The starter does not rotate and there is <b>no</b> "click" heard at the start attempt.	Fault in the start motor feeding.	<ol style="list-style-type: none"> <li>1. Check the cables to the start relay and to the start motor.</li> <li>2. Replace the display/card device.</li> </ol>
The starter does not rotate and there is a "click" heard at the start attempt.	Faulty start motor or start relay	<ol style="list-style-type: none"> <li>1. Check cable connections.</li> <li>2. Replace the start relay.</li> <li>3. Replace the start motor.</li> </ol>
The starter rotate, but the engine does not start.		<ol style="list-style-type: none"> <li>1. Check the fuel supply.</li> <li>2. Check the engine according to the engine manual.</li> <li>3. Check that the white short circuit cable is not connected to earth.</li> </ol>
The battery runs repeatedly empty.	A connected voltmeter to the battery shows a higher voltage at high speed than if the engine not is running.	Replace the battery.
	No voltage different.	<ol style="list-style-type: none"> <li>1. Check engine socket connections.</li> <li>2. Replace the ignition switch.</li> <li>3. Replace the voltage regulator.</li> <li>4. Replace the alternator.</li> </ol>
Electric mower deck adjustment does not work	Works in one direction only.	Replace the display/card device.
	Works not in any direction.	<ol style="list-style-type: none"> <li>1. Check the contact.</li> <li>2. Check the cables.</li> <li>3. Check the motor by connecting an additional battery to the deck cable.</li> <li>4. Replace the display/card device.</li> </ol>
The The PTO clutch does not engage		<ol style="list-style-type: none"> <li>1. Check the clutch cables.</li> <li>2. Replace the display/card device.</li> </ol>
The sand spreader does not work		<ol style="list-style-type: none"> <li>1. Check the cables and connectors.</li> <li>2. Replace the sand spreader motor.</li> </ol>

<b>Edition</b>	<b>Manual</b>	<b>Chapter</b>	<b>Page</b>
2014-12-09	Workshop Manual, GGP Park	7 Electrical System	5

<b>Fault</b>	<b>Cause/Alternative</b>	<b>Action</b>
The starter continues to run after that the engine has started.	Faulty start relay.	Replace the start relay.
The starter operates as soon as the key is in the "ON" position and can be turned off only by removing the key.	Faulty start button. Faulty electronic card.	Change the panel. Change the electronic card.
The battery warning light does not light up with the key in position "ON", but the machine operates.	Faulty electronic card or LED.	Replace the electronic card. NOTE: The work can be finished, but the electronic card needs to be replaced.
The LEDs light up uncontrolled and abnormal.	Faulty, wet or damaged electronic card.	1. Check and dry with low pressure tepid air. (hair dryer). 2. Replace the electronic card.
	Bad earthing of the electronic card.	Check and rework.
The 20 A fuse cuts in.	Short circuit or faulty electronic card.	Replace the electronic card.
The 10 A fuse cuts in.	Faulty battery charging.	Replace the fuse and check the charge circuit.
The display starts up, but with the key in position "START" the starter does not work or works with limited power.	Starting not permitted, due to safety conditions.	After check the conditions are met, check the micro switches.
	The battery has low current.	Recharge the battery.
	Badly earthed battery, starter relay or engine.	Check and repair.
	Start relay is faulty	Replace the start relay.
	Faulty electronic card.	Replace the electronic card.



Edition	Manual	Chapter	Page
2014-12-09	Workshop Manual, GGP Park	7 Electrical System	7

301

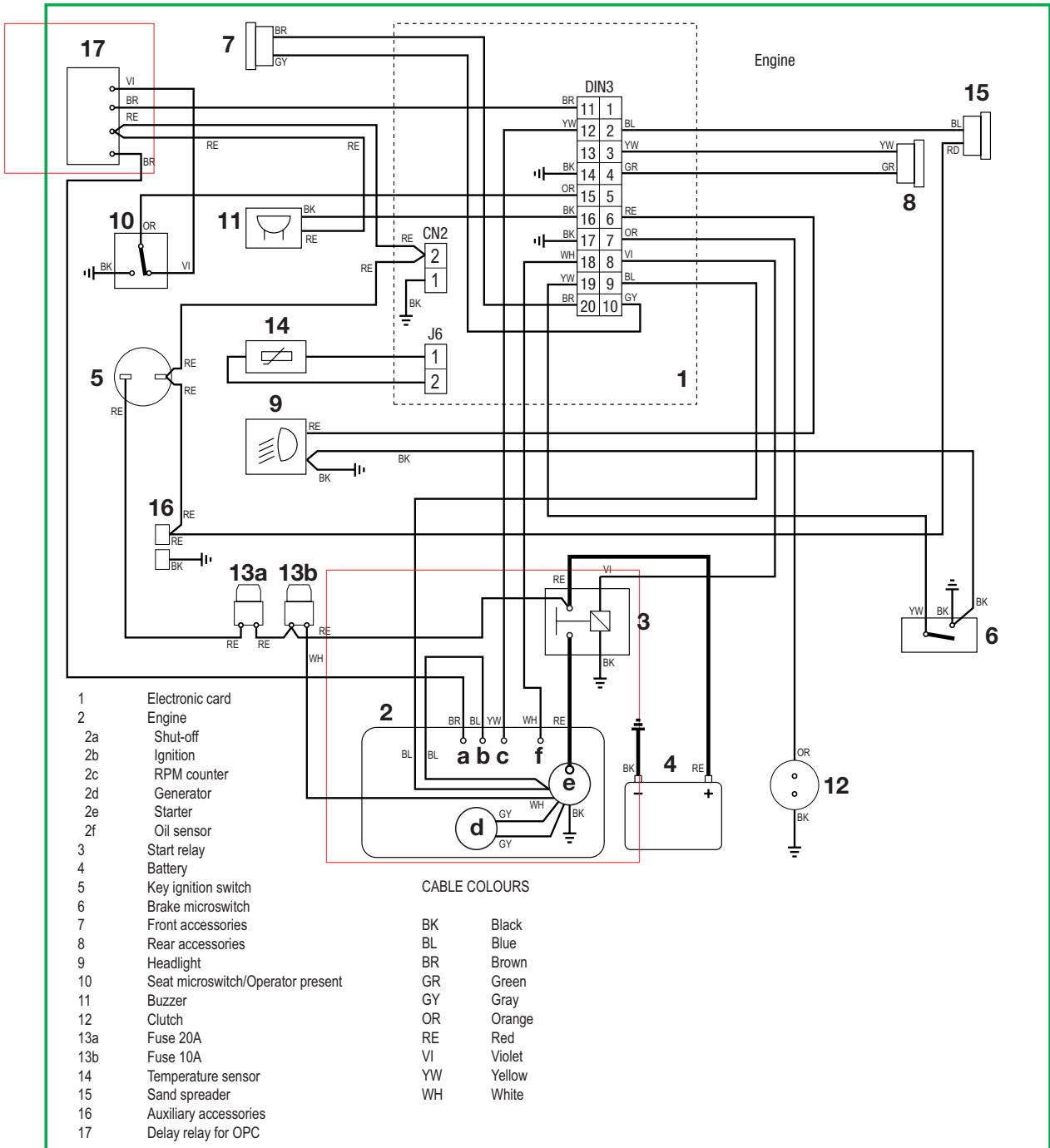



Edition	Manual	Chapter	Page
2014-12-09	Workshop Manual, GGP Park	7 Electrical System	8

## 7.3 Repair and replacements

**Warning**  
 Do not wear rings, metallic bracelet, chain round the neck or similar metal objects when working with the electrical system. It can cause short-circuit, burns and fire.

### 7.3.1 Display/card device

To replace the display/card device proceed as follows:

1. Dismantle the instrument covers. See "Instrument covers" at page 10 in section 2.
2. Dismantle the three hydraulic levers (A) by first loosening their nuts and then unscrew them from their holders.
3. Dismantle the throttle lever by first unscrewing its screw (B).
4. Dismantle the tightening (C) by unscrewing its four screws (E).
5. Loosen and remove the choke parts:
  - Knob
  - Locking nut
  - Nut

Draw the choke wire with its conduit downwards.
6. Unscrew the screws holding the display/card device. Two screws at the front (D) and two screws rear.
7. Loosen carefully the cable connections from the device and lift it carefully up.
8. Move other actual parts from the disassembled card to the new one.
9. Assemble all parts in the reverse order and check all functions.

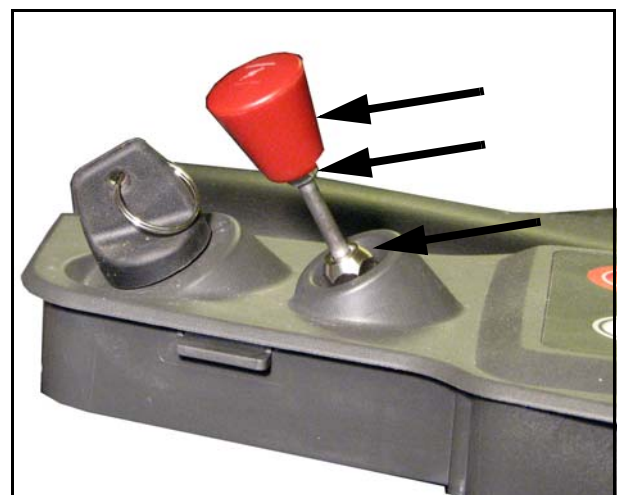
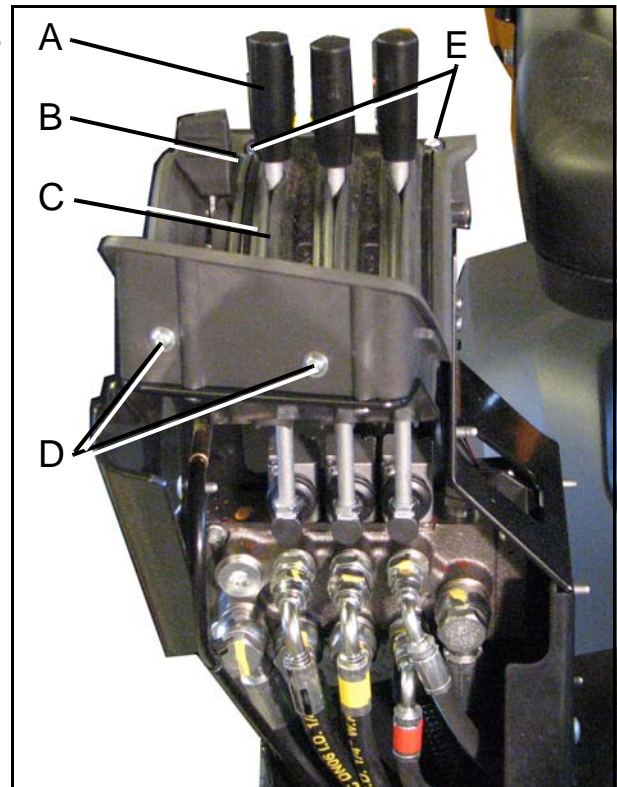

Edition	Manual	Chapter	Page
2014-12-09	Workshop Manual, GGP Park	7 Electrical System	9

### 7.3.2 Connections

The machine is equipped with three kinds of connectors:

- Fixed connectors in plastic holders.
- Tab connectors
- Screw connectors

All connectors shall be kept free from contamination, corrosion and damp.

#### Fixed connectors in plastic holders

To remove the connectors from the plastic holder, put a small screwdriver behind the connector, hold the cable and pull out the connector.

See the figure.



#### Tab connectors

To restore tab connectors if bad crimp forces occur, e.g. after a long time of use, the connector can be pinched by a pliers.

See the figure.

