



Workshop manual

Titan
2008-2012

STIGA



Edition	Manual	Chapter	Page
2008-10-17	Workshop Manual, Stiga Titan	1 General instructions	1

1 General instructions

Contents in this chapter

1.1 Introduction.....	2	1.3.2 Extended guarantee	4
1.1.1 Responsibility declaration.....	2	1.3.3 Component guarantee, chassis.....	4
1.1.2 How this manual is used	2	1.3.4 Exeptions	4
1.1.3 Abbreviations.....	2	1.3.5 Conditions for validity of the war- ranties	4
1.2 Safety Precautions	2	1.4 Unpacking and assembly	5
1.2.1 Symbols and general warnings	3	1.4.1 Unpacking.....	5
1.2.2 Warm parts.....	3	1.4.2 Battery	6
1.2.3 Moving parts.....	3	1.4.3 Assembly	7
1.2.4 Lifting and blocking up.....	3	1.4.4 Final checks.....	9
1.2.5 Cleanliness.....	3	1.5 Service	11
1.2.6 Tightening torque	3	1.6 Technical specifications	12
1.2.7 Sharp edges	3	1.6.1 General tightening torque	14
1.2.8 Replacement parts	3	1.7 Instructions for use	14
1.2.9 Inspection	3		
1.3 Guarantee.....	4		
1.3.1 Guarantee period	4		

General

This Workshop Manual is intended for Stiga Titan models 2008. The article numbers and product names are designated in the table under “Technical specification” at page 21.

This Manual do not cover repair instructions for the motors. Regarding motors, contact the respective representative in the actual country.

This Manual and its specifications are valid for machines in their original design. In case of modified or changed machine, the manual accordance is limited.

The manual is divided in the following chapters:

Chapter 1 is this chapter

Chapter 2 Chassis

Chapter 3 Steering

Chapter 4 Hydraulic system

Chapter 5 Belts

Chapter 6 Control Wires

Chapter 7 Electrical system



Edition	Manual	Chapter	Page
2008-10-17	Workshop Manual, Stiga Titan	1 General instructions	2

1.1 Introduction

1.1.1 Responsibility declaration

In spite of the great care we have taken there may be errors in this publication. The author cannot be made liable for incorrect or missing information. GGP SE reserves the right to regularly change product specifications without prior notice. All the information in this book is based on the information available at the time of production. Illustrations and photographs may be arranged schematically, which implies that one picture may cover several models and therefore not correspond exactly with all models.

1.1.2 How this manual is used

To make this manual easy to understand we have divided the machine into its main systems and components. These parts are now the different chapters in the book. Each chapter is divided up into sections.

There is a quick-guide on the cover of this book, which refers to the different chapters. In each chapter there is a detailed table of contents so that you can easily and quickly find what you are looking for.

For example, if you are looking for information on the Accessory Lifter you will find this in chapter 3, Chassis and Body. On the first page in chapter 3 there is a detailed table of contents which refers to the correct section, in this case section 3.1.

Always check that you are reading the right chapter for your particular machine before starting the repair work.

1.1.3 Abbreviations

The following abbreviation is used in this manual:

PTO Power Take Off

1.2 Safety Precautions

This manual has been written primarily for trained mechanics working in a well-equipped workshop. Nevertheless, the manual contains such detailed information that it can also be of use to owners who wish to carry out simple service and repairs on their machine.

A basic knowledge of repairs, tools and repair instructions is, however, always a prerequisite for first-rate results.

A qualified mechanic should always be consulted if the owner does not have sufficient knowledge to carry out repairs.

During the warranty period all service must be carried out by an Authorised Workshop for the warranty to be valid.

The following basic points should be observed if the machine is to function perfectly:

- Follow the service schedule.
- Be on the alert for sudden vibrations or abnormal noise to avoid major breakdowns.
- Always use Genuine Spare Parts
- Follow the descriptions in this manual carefully. Do not take any short cuts.

Edition	Manual	Chapter	Page
2008-10-17	Workshop Manual, Stiga Titan	1 General instructions	3

1.2.1 Symbols and general warnings



Warning!

This symbol indicates a risk of personal injury or damage if the instructions are not followed.



Note!

This text indicates a risk of damage to the material or risk of unnecessarily complicated work if the instructions are not followed.

1.2.2 Warm parts

Please observe that engine and exhaust system picks up a lot of heat during use. To avoid injuries, allow the machine to cool before any kind of repairs are made to or near parts of the engine or exhaust system.

1.2.3 Moving parts

Always stop the engine and remove the starter key before inspections or repairs are carried out.

Always use extreme caution when testing systems with moving parts to avoid injuries.

Always use Genuine Spare Parts during service work.

1.2.4 Lifting and blocking up

Before work under the machine, always make sure that lifting devices and jack-stands are approved for the weight. Work safe!

1.2.5 Cleanliness

Clean the machine before starting repairs. Dirt that penetrates into sensitive components can seriously influence the service life of the machine.

Special important is the cleanliness when working with the hydraulic system. See special warnings in that chapter.

1.2.6 Tightening torque

Unless otherwise stated the tightening torque in the tables in the section Technical specifications must be used for the different sizes of screws. This does not refer to self-tapping screws, which are mainly used for the assembly of body parts.

1.2.7 Sharp edges

Watch out for sharp edges, especially when working with the mower deck. The blades can be very sharp. Always wear gloves when working with the blades.

1.2.8 Replacement parts

Always use Genuine Spare Parts during service work.

1.2.9 Inspection

Each part dismantled in conjunction with service work must be inspected. Examine for: wear, cracks, out of roundness, straightness, dents, discolouring, abnormal noise and jamming.



Edition	Manual	Chapter	Page
2008-10-17	Workshop Manual, Stiga Titan	1 General instructions	4

1.3 Guarantee

1.3.1 Guarantee period

For consumer use: two years from date of purchase.

For professional use: 200 hours or three months, whichever comes first.

1.3.2 Extended guarantee

The guarantee period can be extended to a maximum of 300 hours or 3 years from the date of purchase provided that the prescribed basic services have been carried out at an authorised Stiga Service workshop during the relevant guarantee period. The services must be verified in the service book.

1.3.3 Component guarantee, chassis

Faults occurring in the machine's bearing in the articulated steering joint, as well as the front and rear chassis, are covered by a 10 year component guarantee from the date of purchase

The guarantee is valid provided that the prescribed basic services have been carried out at an authorised service workshop during the relevant guarantee period. The services must be verified in the service book.

1.3.4 Exeptions

The extended warranty does not cover damage due to the following:

- Neglect by users to acquaint themselves with accompanying documentation.
- Carelessness.
- Incorrect and non-permitted use or assembly.
- The use of non-genuine spare parts.
- The use of accessories not supplied or approved by the manufacturer.

Neither does the warranty cover:

- Wearing components such as blades, belts, wheels, battery and cables.
- Normal wear.
- Engine and transmission. These are covered by the engine manufacturer's warranties, with separate terms and conditions.

The purchaser is covered by the national laws of each country. The rights to which the purchaser is entitled with the support of these laws are not restricted by this warranty.

1.3.5 Conditions for validity of the warranties

The fully completed warranty card must be sent to Stiga's subsidiary or distributor.

In the event of a claim, the service history must be confirmed with a copy of the service book.

Edition	Manual	Chapter	Page
2008-10-17	Workshop Manual, Stiga Titan	1 General instructions	5

1.4 Unpacking and assembly

Every Stiga Titan has undergone an extensive control programme before delivery. The machines are delivered as completely assembled as possible.

Thanks to this the assembly on delivery is rapid and easy.

The correct and careful assembly of the machine on delivery is a simple way of ensuring satisfied customers!



Note!

The machine shall remain placed on the pallet during the unpacking and assembly.

1.4.1 Unpacking

Open up the crate and release the part as follows:

1. Check the air pressure in the tyres. The pressure is designated adjacent to the actual wheel.
The air pressure in the tyres is of critical importance for the performance and handling of the machine. The correct air pressure for mowing is 0.9 bar in all tyres. When using the machine with other implements, see the respective implement manual regarding the tyre pressure.

However, the maximum permitted pressure is always 1,3 bar.

Too high pressure in the tyres leads to that the machine drives poor due to:

- A small surface in contact to the ground.
 - Hard tyre = less flexibility = self cleaning characteristic deteriorate.
2. Remove the following parts from the package and put them on the floor.
 - The seat and, if applicable, the neck rest.
 - The steering wheel.
 - The plastic bag, containing owners manuals, information video and assembly screws.

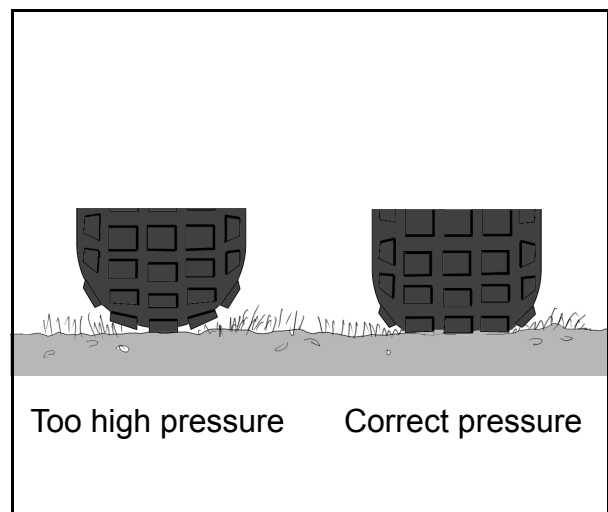

Edition	Manual	Chapter	Page
2008-10-17	Workshop Manual, Stiga Titan	1 General instructions	6

1.4.2 Battery

The battery is a closed type which means that water or electrolyte cannot be topped up.

The battery charge level is read at the indicator eye on top of the battery. The charge level can also be read by a voltmeter, where the following values are valid:

12,7 V Fully charged

12,4 V Half charged

12,0 V Empty, no current

Warnings!



Do not wear rings, metallic bracelet, chain round the neck or similar metal objects when working with the battery. It can cause short-circuit, burns and fire.



The battery must be fully charged before being used for the first time. The battery must always be stored fully charged. If the battery is stored while discharged, serious damage will occur.



If the cables are disconnected/connected in the wrong order, there is a risk of a short-circuit and damage to the battery.



If the cables are interchanged, the generator and the battery will be damaged.



The engine must never be driven with the battery disconnected. There is a risk of serious damage to the generator and the electrical system.

Installation of battery

See also the respective installation manual, delivered with the machine.

After the battery is charged, remove the motor casing and install it in the machine. Connect first the red cable to plus (+) and then the black cable to minus (-).

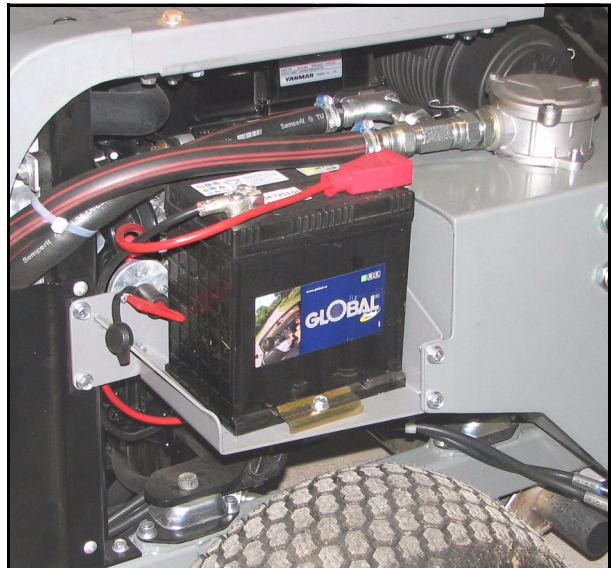

Charging with the engine

The battery can be charged using the engine's generator as follows:

1. Install the battery in the machine as shown below.
2. Place the machine outdoors or install an extraction device for the exhaust fumes.
3. Start the engine according to the instructions in the user guide.
4. Allow the engine to run continuously for 45 minutes.
5. Stop the engine. The battery will now be fully charged.

Charging using battery charger

The battery is allowed to be charged with max 4 A. At higher charging currents, the battery will be damaged.

Edition	Manual	Chapter	Page
2008-10-17	Workshop Manual, Stiga Titan	1 General instructions	7

1.4.3 Assembly

The assembly procedure shall take place in a clean, well illuminated and dry place.

Assemble the machine as follows:

Assembly of steering wheel

The machine is delivered without the steering wheel with its rod disassembled. Assemble as follows:

1. Install the steering column jacket on the steering column
2. Check that the holes coincide.
3. Secure by knocking in the tension pin fully. Use a counterhold.
Also make sure that the logo on the steering wheel is in the correct position.

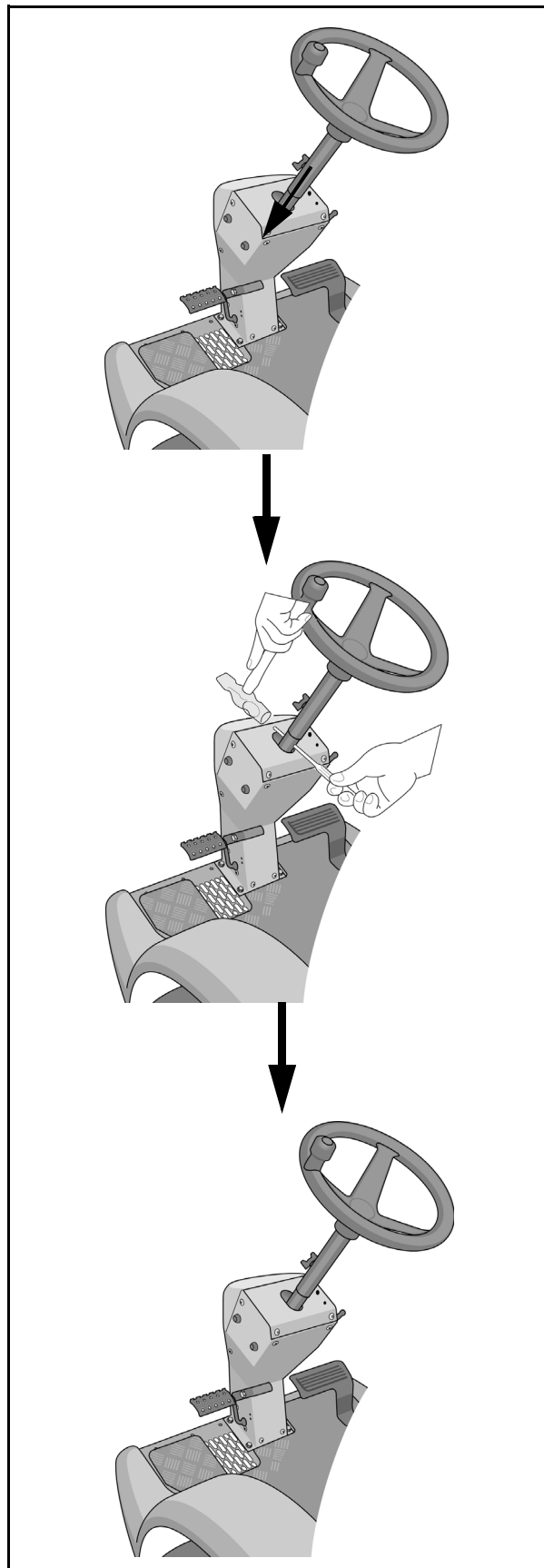

Edition	Manual	Chapter	Page
2008-10-17	Workshop Manual, Stiga Titan	1 General instructions	8

Assembly of seat

Install the seat as follows:

1. Place the seat in place and assemble the two front screws with nuts. Don't tight yet.
2. Assemble the two rear screws with nuts.
3. Tighten the four screws.

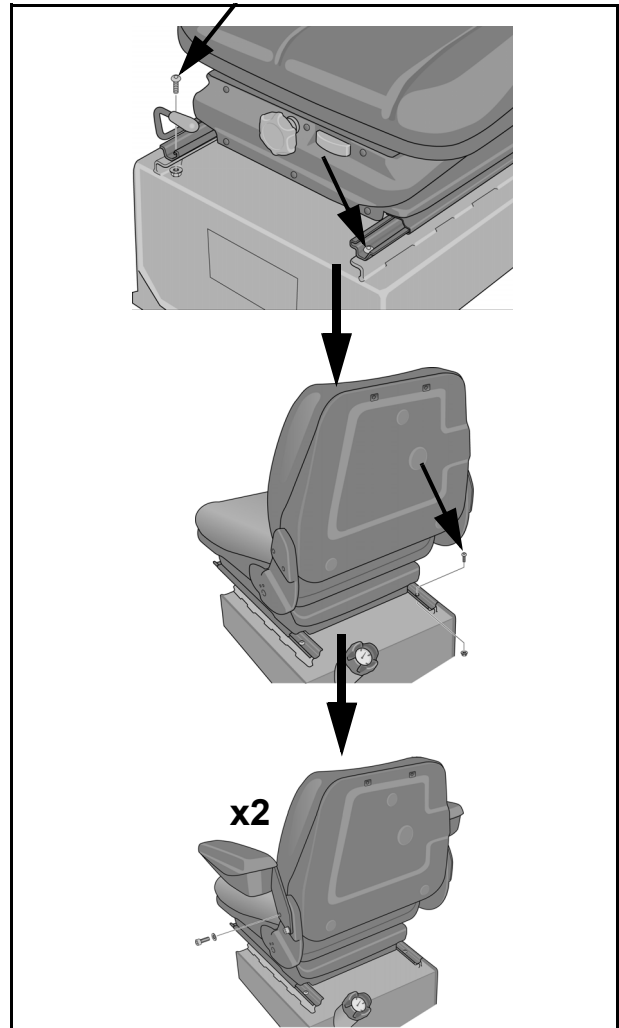

Assembly of headrest

Install the headrest as follows:

1. Hold the headrest in place and assemble the two screws .
2. Tighten the screws.

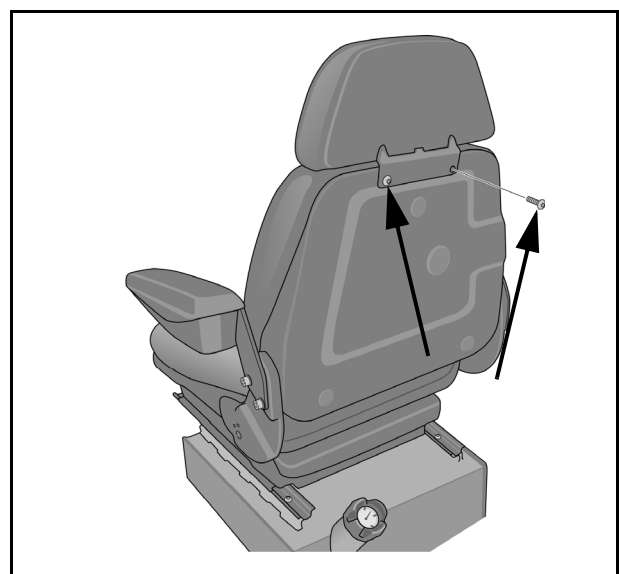



Edition	Manual	Chapter	Page
2008-10-17	Workshop Manual, Stiga Titan	1 General instructions	9

1.4.4 Final checks

Actions before starting

Carry out the following before starting the machine:

- Check/top up with fuel.
- Check the engine oil level.
- Check the coolant level.
- Check to make sure that the air filter indicator has not been tripped.
- Check that the water separator's and fuel filter's taps are open.
- Check that the water separator does not contain water. Drain if necessary.
- Check the oil level in the hydraulic tank. See "3.5.8" in instructions of use.
- Carry out safety checks.
- Check that the disengagement lever is in the inner position. See "3.4.19".

Test driving

Drive the machine for a few minutes. Test all the functions. Pay special attention to the safety functions, see next page. If the machine is to be delivered with mower deck or other accessories, fit these before test driving the machine.



Edition	Manual	Chapter	Page
2008-10-17	Workshop Manual, Stiga Titan	1 General instructions	10

General safety checks

Object	Result
Fuel lines and connections.	No leak.
Power cables.	All insulation intact. No mechanical damage.
Exhaust system.	No leakage in the connections. All screws tightened.
Hydraulic hoses.	No leakage. No damage.
Drive the machine forwards/ backwards and release the drive/service brake pedal.	The machine should stop.
Test driving.	No unusual vibrations. No unusual noise.

Electric safety check

Status	Action	Result
The clutch-brake pedal not depressed. PTO not activated.	Attempt to start.	The engine should not start.
The clutch-brake pedal not depressed. PTO activated.	Attempt to start.	The engine should not start.
Engine running. PTO activated.	The operator leaves the seat.	PTO should dis- engage.
Cruise control activated.	The operator leaves the seat.	Cruise control should disengage.
Cruise control activated.	Clutch-brake pedal depressed.	Cruise control should disengage.
Control for implement lifter not in floating position.	Attempt to engage PTO.	PTO should not be able to engage.



Edition	Manual	Chapter	Page
2008-10-17	Workshop Manual, Stiga Titan	1 General instructions	11

1.5 Service

Every new machine is delivered with a service book. Every service shall be documented in the service book. This service book is part of the active post-market programme and shall be kept in a safe place during the entire lifetime of the machine. Hand over the service book if the machine is sold in 2:nd hand.

Service shall be carried out according to the table below, regarding items and intervals.

Service point	1st time	Interval	See paragraph in instruc- tions of use
	Hours of operation/Calendar months		
Water separator, check		50/-	6.4
Pre-filter, cleaning			6.4
Fuel filter, replace		400/-	6.5
Tyre pressure, check, adjust			6.6
Engine oil, filter, change	50/12	200/12	6.7
Hydraulic oil, filter, change/clean	50/12	400/12	6.8
Wheel motors , change oil	50/12	200/12	6.9
Belt transmis- sions, check	50	200/-	6.10
Cooling system, clean		1000/12	6.11
Battery, check		50/-	6.12
Air filter, clean pre-filter			6.13
Air filter, change inner filter			6.13
Lubrication			6.14
Adjusting valves		1000/-	6.15
Grinding valves		2000/-	6.15



Edition	Manual	Chapter	Page
2008-10-17	Workshop Manual, Stiga Titan	1 General instructions	12

1.6 Technical specifications

	TITAN 20 B	TITAN 26 B	TITAN 26 H	TITAN 26 HS
	13-7421-21	13-7432-21	13-7434-21	13-7436-21
Basic machine data				
Machine type	Multi purpose implement carrier	Multi purpose implement carrier	Multi purpose implement carrier	Multi purpose implement carrier
Measures MAX LxWxH (mm)	2300x1060x1950	2300x1060x1950	2300x1090x2000	2300x1090x2000
Height over R.O.P.S.	1950	1990	1990	1990
Height over seat	1300	1300	1500	1500
Wheelbase	1200	1200	1200	1200
Weight, without operator	600 kg	610 kg	620 kg	630 kg
Weight, max	900 kg	1100 kg	1100 kg	1100 kg
Weight distribution with driver	Rear: 60%, Front: 40%	Rear: 60%, Front: 40%	Rear: 60%, Front: 40%	Rear: 60%, Front: 40%
Weight distribution with driver, deck in transport position	Rear: 30%, Front: 70%	Rear: 30%, Front: 70%	Rear: 30%, Front: 70%	Rear: 30%, Front: 70%
Engine				
Type	Yanmar 3TNV70-XMHS Naturally aspirated, watercooled, 4 stroke, 3 cylinder IDI diesel engine	Yanmar 3TNV76-XMHS Naturally aspirated, watercooled, 4 stroke, 3 cylinder IDI diesel engine	Yanmar 3TNV76-XMHS Naturally aspirated, watercooled, 4 stroke, 3 cylinder IDI diesel engine	Yanmar 3TNV76-XMHS Naturally aspirated, watercooled, 4 stroke, 3 cylinder IDI diesel engine
Gross power @ 3600 rpm	17 kW, 23 Hp	22 kW, 30 Hp	22 kW, 30 Hp	22 kW, 30 Hp
Gross power @ 3000 rpm	15 kW, 20 Hp	19 kW, 26 Hp	19 kW, 26 Hp	19 kW, 26 Hp
Engines power rating, net	ISO 3046/1	ISO 3046/1	ISO 3046/1	ISO 3046/1
Net power @ 3600 rpm	16 kW, 21 Hp	21 kW, 29 Hp	21 kW, 29 Hp	21 kW, 29 Hp
Net power @ 3000 rpm	14 kW, 19 Hp	18,5 kW, 25 Hp	18,5 kW, 25 Hp	18,5 kW, 25 Hp
High idle speed	3200 rpm	3200 rpm	3200 rpm	3200 rpm
Low idle speed	1250 rpm	1250 rpm	1250 rpm	1250 rpm
Bore	70 mm	76 mm	76 mm	76 mm
Stroke	74 mm	82 mm	82 mm	82 mm
Displacement	854 cc	1115 cc	1115 cc	1115 cc
Low temp specification	-20°C	-20°C	-20°C	-20°C
Low temp starting aid	standard	standard	standard	standard
Emission standard	EU: N/A. US: EPA Tier 4	EU: Stage 3A (97/68/EC) US: EPA Interim Tier 4	EU: Stage 3A (97/68/EC) US: EPA Interim Tier 4	EU: Stage 3A (97/68/EC) US: EPA Interim Tier 4
Specific fuel consumption @ rated net output	294 g/KW-h	287 g/KW-h	287 g/KW-h	287 g/KW-h
Specific fuel consumption @ 75% output	302 g/KW-h			
Specific fuel consumption @ 50% output	363 g/KW-h			
Gradient, engine	25° (30° for 3 min)	25° (30° for 3 min)	25° (30° for 3 min)	25° (30° for 3 min)
Fuel system				
Fuel pump	mechanical	mechanical	mechanical	mechanical
Fuel type	Diesel (EN590:96)	Diesel (EN590:96)	Diesel (EN590:96)	Diesel (EN590:96)
Alternative fuel	Max 5% RME (EN24214)	Max 5% RME (EN24214)	Max 5% RME (EN24214)	Max 5% RME (EN24214)
Water separator	standard	standard	standard	standard
Fuel filter type	Paper element cartridge	Paper element cartridge	Paper element cartridge	Paper element cartridge
Air cleaner				
Type	Dual filter, dry type	Dual filter, dry type	Dual filter, dry type	Dual filter, dry type
Backpressure indicator	Yes	Yes	Yes	Yes
Extra large filter for extended cleaning intervals	Yes	Yes	Yes	Yes
Volumes				
Fuel tank capacity	~40 L	~40 L	~40 L	~40 L
Engine coolant capacity	~4 L	~4 L	~4 L	~4 L
Engine oil capacity	~2,8 L	~3,4 L	~3,4 L	~3,4 L
Hydraulic system volume	~20 L	~20 L	~20 L	~20 L
Hydraulic system change volume	~17 L	~17 L	~17 L	~17 L
Reduction gear in wheel motors	~0,2 l / wheel	0,2 l / wheel	0,2 l / wheel	0,2 l / wheel



Edition	Manual	Chapter	Page
2008-10-17	Workshop Manual, Stiga Titan	1 General instructions	13

	TITAN 20 B 13-7421-21	TITAN 26 B 13-7432-21	TITAN 26 H 13-7434-21	TITAN 26 HS 13-7436-21
Hydraulic systems				
Travel system, type	Permanent 4x4, hydraulic wheel motors	Permanent 4x4, hydraulic wheel motors	Permanent 4x4, hydraulic wheel motors	Permanent 4x4, hydraulic wheel motors
Max travel speed	20 km / h	20 km / h	20 km / h	24 km / h
Wheel size front and rear	20x10.00x10	20x10.00x10	20x10.00x10	23x10.50x12
Travel pump	23,9cc variable axial piston pump	23,9cc variable axial piston pump	24,5cc variable axial piston pump	24,5cc variable axial piston pump
Travel pump version	Shoeless type pistons	Shoeless type pistons	Shoe type pistons	Shoe type pistons
Travel pump operating pressure	0-280 bar	0-280 bar	0-280 bar	0-280 bar
Travel pump, charge pump	4 cc inner rotor gear pump	4 cc inner rotor gear pump	4 cc inner rotor gear pump	4 cc inner rotor gear pump
Travel pump charge pump operating pressure	2,9 bar	2,9 bar	2,9 bar	2,9 bar
Wheel motors	13 cc axial piston motor w. gear reduction	13 cc axial piston motor w. gear reduction	13 cc axial piston motor w. gear reduction	13 cc axial piston motor w. gear reduction
Wheel motors front max load	650 kg / pcs	650 kg / pcs	650 kg / pcs	650 kg / pcs
Wheel motors rear max load	650 kg / pcs	650 kg / pcs	650 kg / pcs	650 kg / pcs
Wheel motors, front	Shoeless type pistons	Shoeless type pistons	Shoe type pistons	Shoe type pistons
Wheel motors, rear	Shoe type pistons	Shoe type pistons	Shoe type pistons	Shoe type pistons
Auxiliary pump	4,2 cc gear pump	4,2 cc gear pump	4,2 cc gear pump	4,2 cc gear pump
Auxiliary pump operating pressure	125 bar	125 bar	125 bar	125 bar
Hydraulic oil cooling system	Tube	Tube	Radiator	Radiator
Hydraulic oil type	10W-30	10W-30	10W-30	10W-30
Reduction gear in wheel motors, oil type	#90 or SAE 50	#90 or SAE 50	#90 or SAE 50	#90 or SAE 50
Power take off (PTO)				
PTO type	Belt	Belt	Hydraulic	Hydraulic
PTO pump	-	-	14 cc gear pump	14 cc gear pump
PTO pump operating pressure	-	-	210 bar	210 bar
PTO pump max output	-	-	42 l/min	42 l/min
Frame and steering				
Steering system	Genuine articulated steering	Genuine articulated steering	Genuine articulated steering	Genuine articulated steering
Steering angle	+/- 55°	+/- 55°	+/- 55°	+/- 55°
Steering	Fully hydraulic	Hydraulic	Hydraulic	Hydraulic
Frame	HD welded profile frame	HD welded profile frame	HD welded profile frame	HD welded profile frame
Frame material	Box section, 80x50x4 mm	Box section, 80x50x4 mm	Box section, 80x50x4 mm	Box section, 80x50x4 mm
Operator area				
Seat type	Pro high comfort	Pro high comfort	Pro high comfort	Pro high comfort
Seat suspension adjustable	Yes	Yes	Yes	Yes
Seat position adjustable	Yes	Yes	Yes	Yes
Backrest position adjustable	Yes	Yes	Yes	Yes
Arm rest	Yes	Yes	Yes	Yes
Extended seat back	-	-	Yes	Yes
Speed control	HST pedal	HST pedal	HST pedal	HST pedal
Cruise control	yes	Yes	Yes	Yes
Low fuel warning	-	-	Yes	Yes
Head light	Yes	Yes	Yes	Yes
Hour meter	Yes	Yes	Yes	Yes
Seat heating, electrical	Option	Option	Option	Option
Safety				
Roll over protection system (R.O.P.S)	option	option	option	option
Cabin	-	option	option	option
Cabin heating	-	option	option	option
Air conditioning	-	option	option	option
Implement interface				
Implement attachment front	no tools required	no tools required	no tools required	no tools required
Lift capacity front	200 kg**	250 kg**	250 kg**	250 kg**
Side floating holder	yes	yes	yes	yes
Implement attachment rear	no tools required	no tools required	no tools required	no tools required
Load capacity rear	200 kg**	300 kg**	300 kg**	300 kg**
Load capacity top	80 kg**	100 kg**	100 kg**	100 kg**
Trailer weight, max	50-300 kg*	50-300 kg*	50-500 kg*	50-500 kg*

*Note: Vehicle combination total weight! **Note: Machine balance / weight distribution!



Edition	Manual	Chapter	Page
2008-10-17	Workshop Manual, Stiga Titan	1 General instructions	14

1.6.1 General tightening torque

Unless otherwise stated, the following tightening torque are applicable for screws and nuts on the machine:

Tightening torques

Thread	Torque
M5	5 Nm
M6	9 Nm
M8	22 Nm
M10	45 Nm

1.7 Instructions for use

Some procedures, e.g. changing motor oil, motor filter and items in final checks etc., are referred to the instruction for use, delivered with the machine.

The instruction of use is written in 16 languages and divided in two parts. The first part always contains the languages SV, FI, DA, NO, DE, EN, FR and NL.

Edition	Manual	Chapter	Page
2008-10-23	Workshop Manual, Stiga Titan	2 Chassis and body	1

2 Chassis and body

Contents in this chapter

2.1 Description	2
2.2 Cruise control	3
2.2.1 Description.....	3
2.2.2 Disassembly	3
2.2.3 Assembly	4
2.3 Cooler	5
2.3.1 Description.....	5
2.3.2 Disassembly	5
2.3.3 Assembly	6
2.3.4 Filling coolant.....	6
2.3.5 Lubrication chassis	7

General

To facilitate the driving, handling of work equipment and to make it comfortable for the driver, the machines are equipped with a various number of aid equipments. These equipments can be hydraulic, electric or mechanic devices.

This chapter gives a brief description of the equipments and describes their repair and replacements.

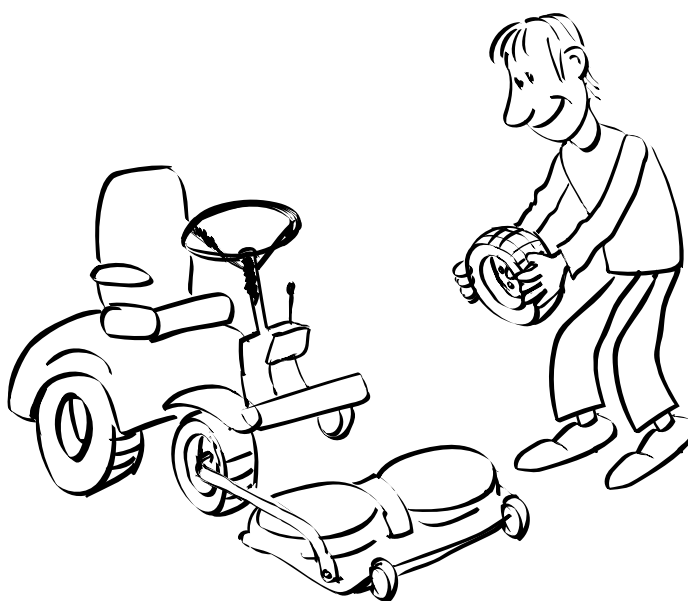

Edition	Manual	Chapter	Page
2008-10-23	Workshop Manual, Stiga Titan	2 Chassis and body	2

2.1 Description

The chassis is built up on and around a articulated frame with its articulation point in the middle. This configuration imply that both the front wheels and the rear wheels participate in the turning actions and the rear wheels follow the traces of the front wheels. This is a great advantage in common and a requirement when cutting around trees and corners. The rear wheel will never pass a bend in an inner circle and interfere with the obstruction.

This configuration also gives an optimal small uncut circle, when driving with maximal turning.

The articulated frame is also articulating in the vertical plane with $\pm 6^\circ$. This makes it possible for all the four wheels to press evenly against the ground when the ground is bumpy.

To the chassis is also fitted control organs, which conduct operator commands to the actual device at the machine. I.e. wire and rod between brake and pedal, throttle wire, etc.

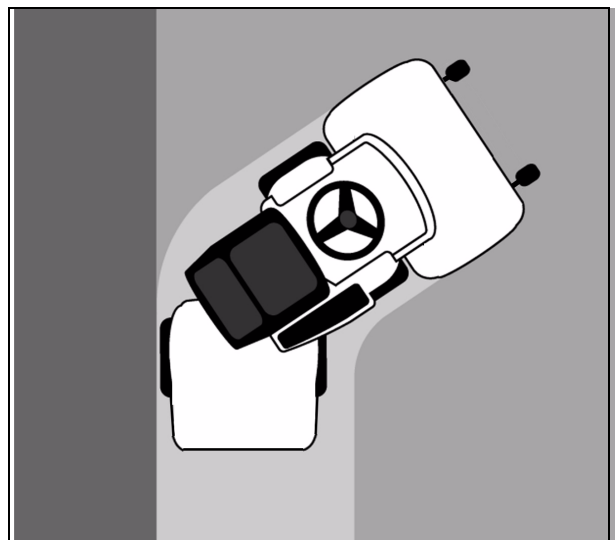
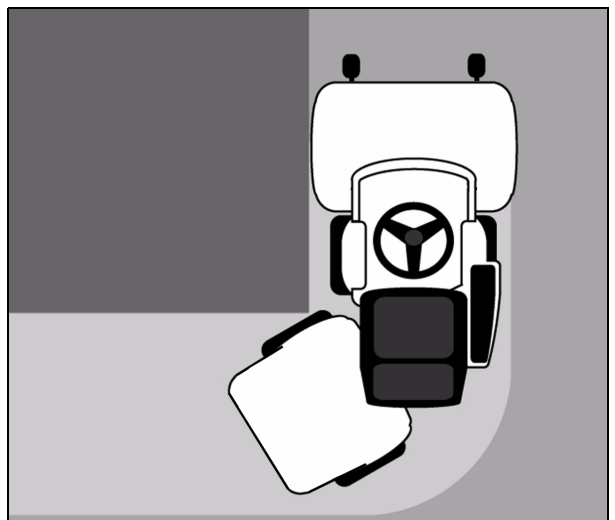
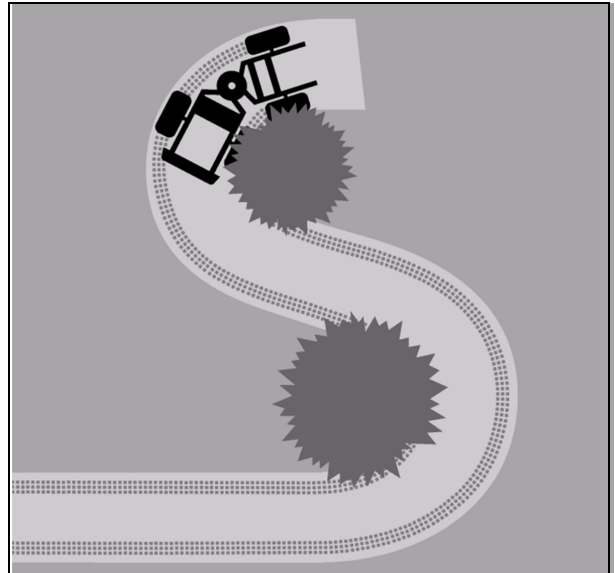

Edition	Manual	Chapter	Page
2008-10-23	Workshop Manual, Stiga Titan	2 Chassis and body	3

2.2 Cruise control

2.2.1 Description

The cruise control works as a temporary lock for the speed lever at the hydraulic pump.

The electromagnet (A) is sliding along the Brake plate (B). When the cruise control engages, 12 V is connected to the electromagnet (A) which locks in its actual position against the brake plate (B). Such the mechanics, drive pedal, linkage and hydraulic pump lever are locked in position for desired speed.



2.2.2 Disassembly

Disassemble the speed cruiser as follows:

1. Remove the upper and the right motor hoods.
2. Disconnect the drive wire from the pump lever by loosening the nut. Use a 10 mm spanner. To lock the stud in the hole, preventing it to rotate, press the wire end upwards.
3. Disconnect the magnet cables.
4. Loosen the screw and nut, holding the lever to the pump. Use two 13 mm spanners. Remove the parts:
 - Screw
 - Nut
 - Lever
 - Distance
 - Spring
 - Magnet

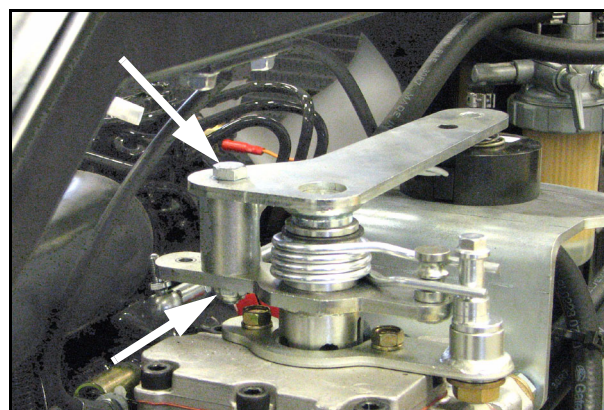
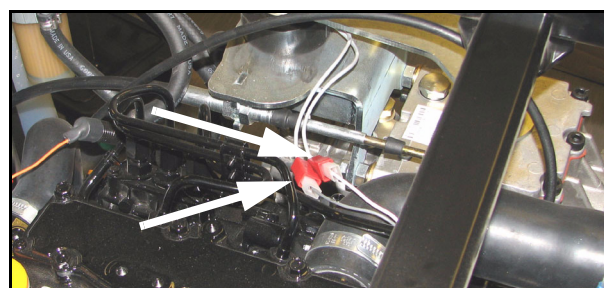

Edition	Manual	Chapter	Page
2008-10-23	Workshop Manual, Stiga Titan	2 Chassis and body	4

5. If necessary, loosen the brake bracket by unscrewing the two nuts.
6. Loosen the drive wire from the brake bracket.

2.2.3 Assembly

Assemble all parts in reverse order. See also the figure.

If the drive wire has been removed from the brake bracket, adjust the wire. See “2.4.5 Adjustment”.

- ! **Note!**
Check that the magnet tab (D) fits in the lever hole.

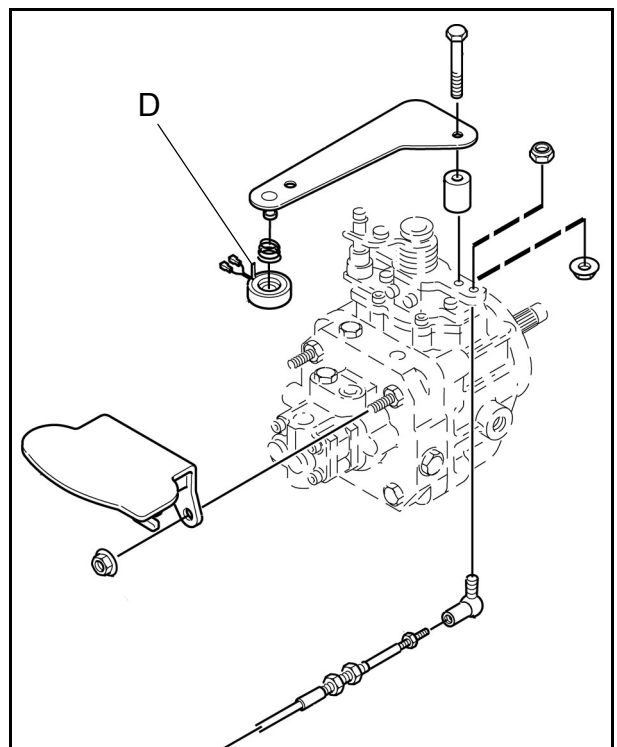
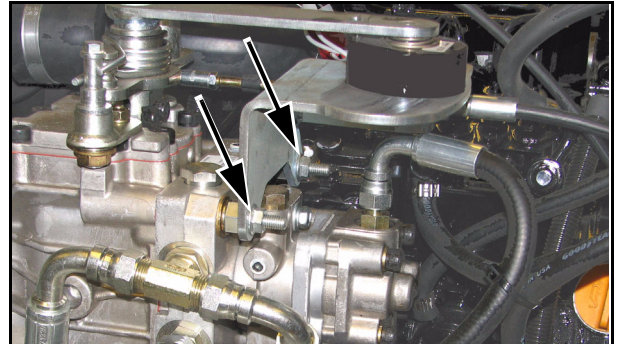

Edition	Manual	Chapter	Page
2008-10-23	Workshop Manual, Stiga Titan	2 Chassis and body	5

2.3 Cooler

2.3.1 Description

The radiator is intended to keep the motor temperature constant at the working temperature during operation. It is therefore important that the coolant can flow freely through the radiator.

2.3.2 Disassembly

Disassemble the radiator as follows:

1. Remove the motor hoods:
 - Turn and remove the screws (A).
 - Unhook the straps (B X 4).
 - Lift up and remove the 4 hoods.
 - Unscrew the 4 screws (C) and remove the top hood.



The coolant is very hot direct after use. Let the motor cool down before draining the coolant.

2. Place a tray under the lower radiator hose and loosen the hose from the radiator. The hose clamp is accessible from the under side.
3. Remove the radiator cap to let the air into the system for easier draining.
4. Loosen the upper radiator hose and the expansion tank hose from the radiator.

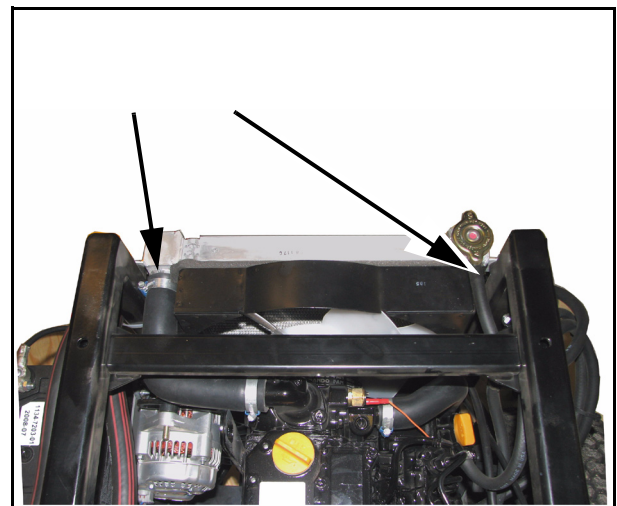
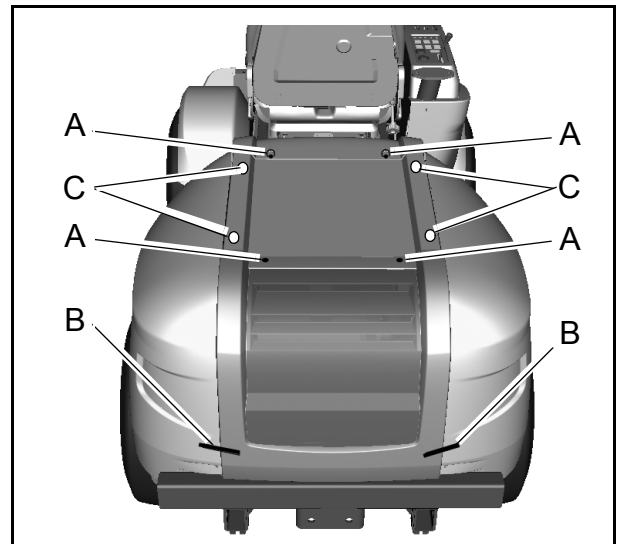

Edition	Manual	Chapter	Page
2008-10-23	Workshop Manual, Stiga Titan	2 Chassis and body	6

5. Loosen the four screws (D) for the oil cooler and fold out the cooler forwards.

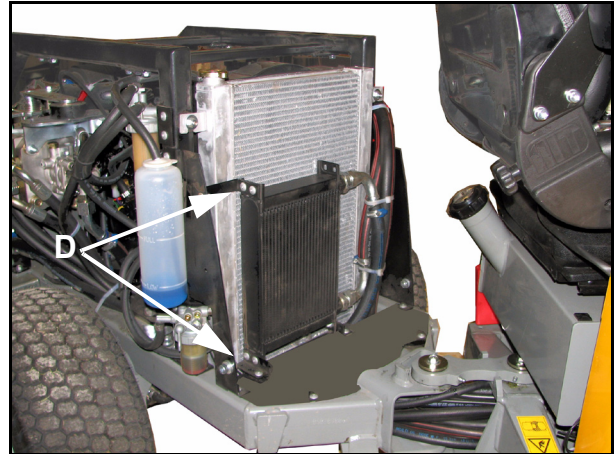

6. Loosen the radiator by unscrewing two screws at the top and two nuts from the under side.

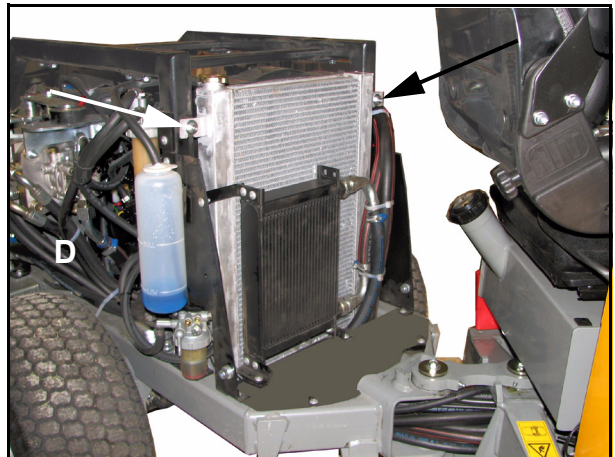

2.3.3 Assembly

All assembly is performed in the reverse order.

2.3.4 Filling coolant

The coolant must meet the following requirements:

- Always use a mixture of refrigerant and water. Never use just water.
- Mix the water and refrigerant according to the refrigerant supplier's instructions.
- Never mix different refrigerants.
- Use soft water (no calcium content), distilled or demineralised water.

Top up as follows:

1. Check that all the plugs in the cooling system are installed and sealed.
2. Check that all the taps in the cooling system are closed and sealed.
3. Check that all the hoses in the cooling system are intact and sealed.
4. Unscrew the radiator cap.

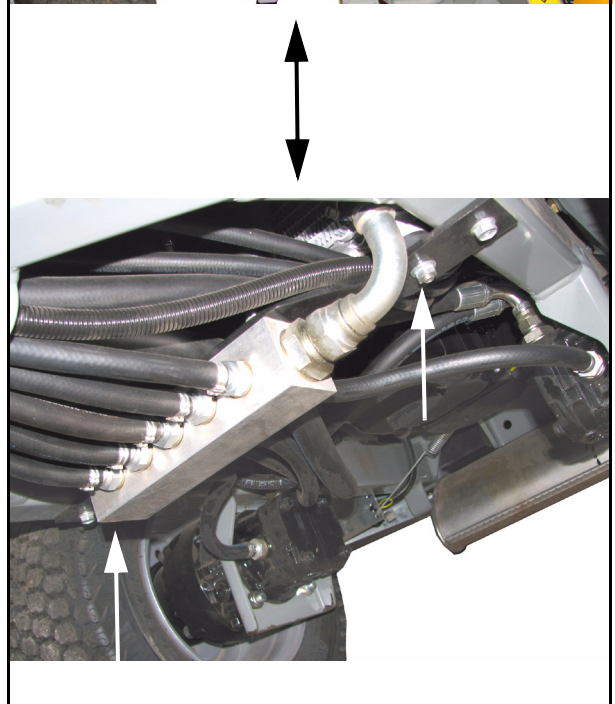

Edition	Manual	Chapter	Page
2008-10-23	Workshop Manual, Stiga Titan	2 Chassis and body	7

6. Slowly fill the radiator with coolant. Air bubbles must not form when filling. Fill up to the filler hole.
7. Reinstall the radiator cap.
8. Open the cap on the expansion tank (K) and top up the mixture to the lower mark which is the level when the engine is cold.
9. Close the cap for the expansion tank.
10. Run the engine to operating temperature and check the level in the expansion tank. The level should now be at the upper mark (T), which is the level for when the engine is hot.
11. If the level is not up to the upper mark, allow the engine to cool and then top up with coolant in the expansion tank.

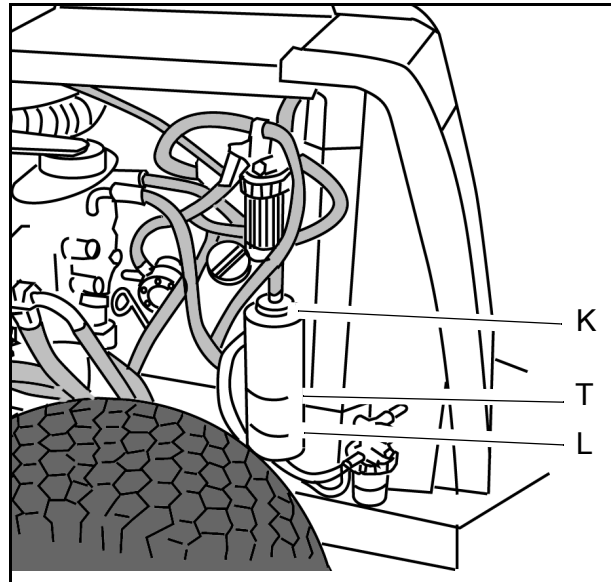

2.4 Lubrication chassis

All lubrication points according to the table below must be lubricated after every 50 operating hours as well as after each clean.

Use a grease gun, filled with universal grease. Pump until grease protrudes. The lubrication points are shown in the figure at the next page



Note the belts when lubricating. Belts must not come into contact with oil or grease.

Edition	Manual	Chapter	Page
2008-10-23	Workshop Manual, Stiga Titan	2 Chassis and body	8

Object	Lubrication nipples / action	Figure
Tension arm, pump belt	1 lubrication nipple.	A
Lifting fork, turning	1 lubrication nipple	B
Lifting fork, up-down	2 lubrication nipples	G, H
Lifting cylinder	2 lubrication nipples	C, E
Control cylinder	2 lubrication nipples	D, F
Pivot point	3 lubrication nipples	J
Tension arm, auxiliaries belt (Only 20B and 26B)	1 lubrication nipple. Be careful with the belts. Belts must not come into contact with grease.	L
Tension arm, rear implement belt (Only 20B and 26B)	1 lubrication nipple. Be careful with the belts. Belts must not come into contact with grease.	K
Throttle cable	Lubricate the cable ends using an oil can at the same time as activating the respective control. Preferably carried out by two people.	M
Cruise control plate	Clean and lubricate the cruise control plate before the first start every day.	N

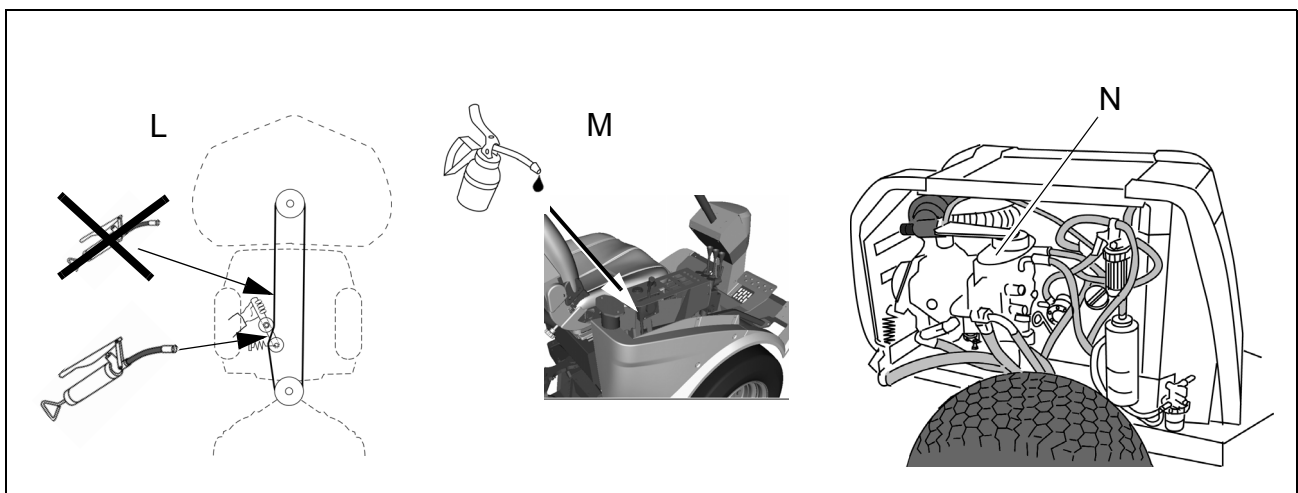

Edition	Manual	Chapter	Page
2008-10-23	Workshop Manual, Stiga Titan	2 Chassis and body	9

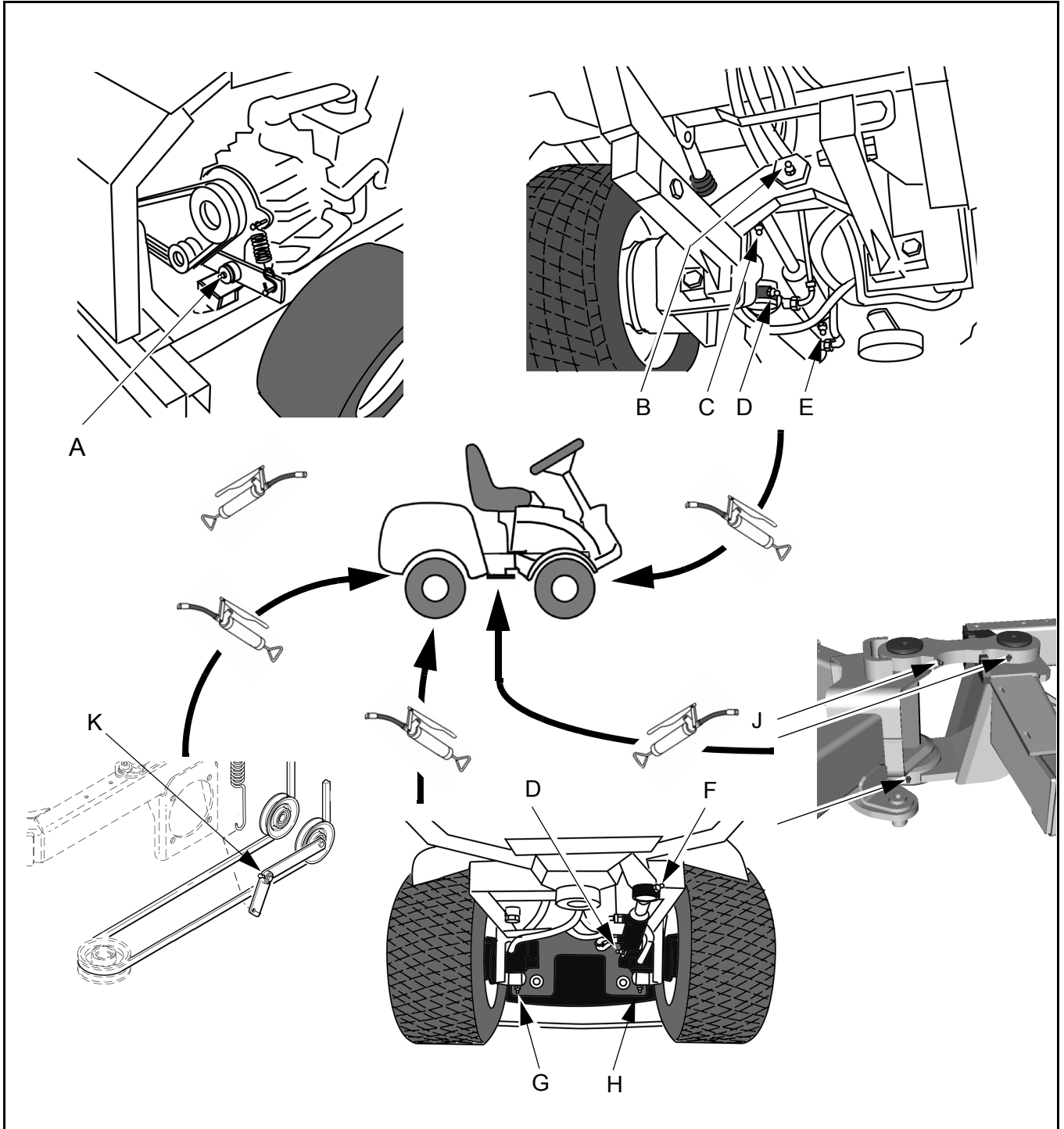

Edition	Manual	Chapter	Page
2008-10-17	Workshop Manual, Stiga Titan	3 Steering	1

3 Steering

Contents in this chapter

3.1 Description	2
3.1.1 Disassembly the steering servo	3
3.1.2 Repair of the steering servo	4
3.1.3 Assembly the steering servo	4
3.1.4 Trouble shooting.....	5

General

The articulation steered machines are equipped with a hydraulic assisted steering system. The system works with a hydraulic cylinder, forcing the front and rear frames into desired angels. The hydraulic assisted system gets its power from the pump for external hydraulics, integrated to the driving pumps.

This chapter contains a brief description of the function and describes repair, replacements and adjustments of stressed parts of the steering system.



Edition	Manual	Chapter	Page
2008-10-17	Workshop Manual, Stiga Titan	3 Steering	2

3.1 Description

The description of the oil flows in the hydraulic assisted steering system is given in section 4.

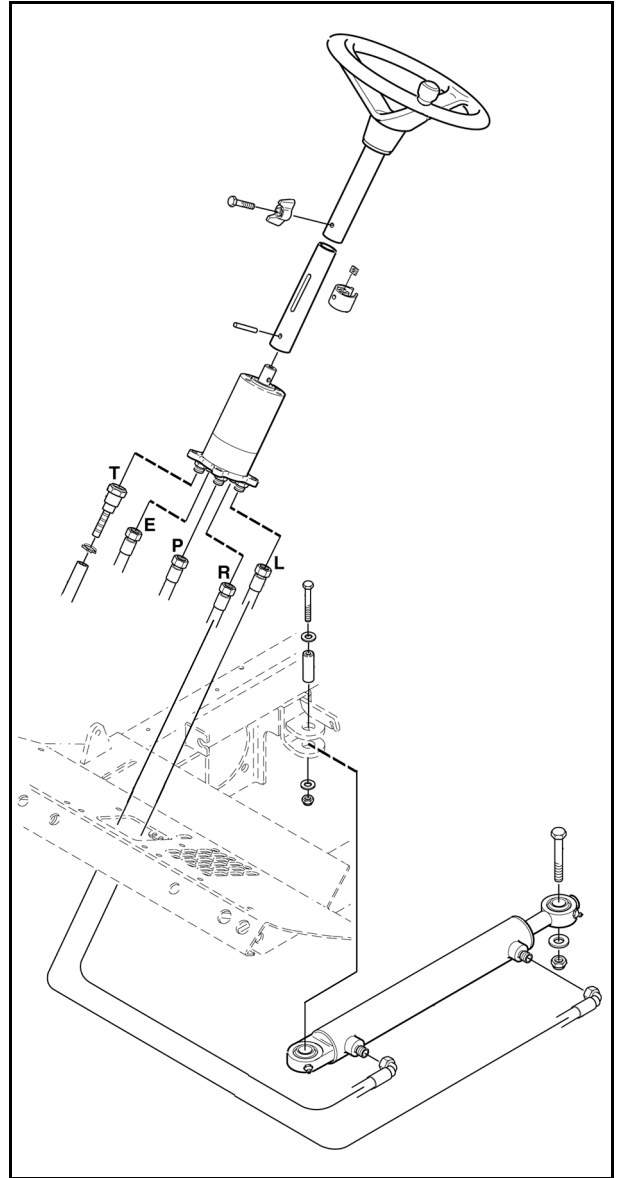

Edition	Manual	Chapter	Page
2008-10-17	Workshop Manual, Stiga Titan	3 Steering	3

3.1.1 Disassembly the steering servo

1. Dismantle the steering bracket rear cover by unscrewing the four screws.

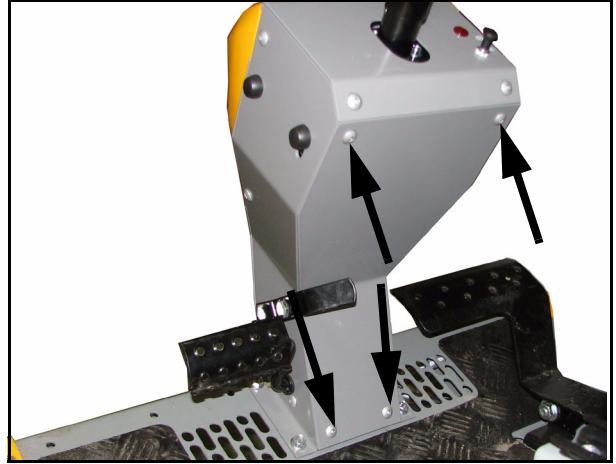

2. Disassemble the steering wheel, by knocking out the tension pin.

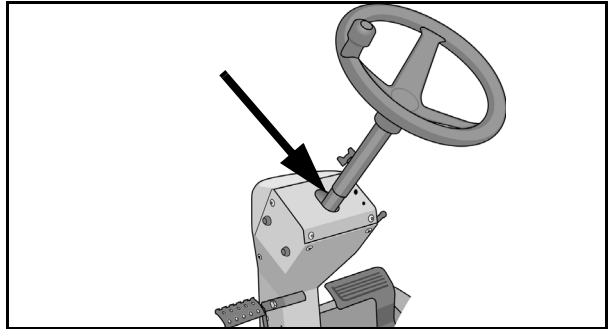

3. Dismantle the front cover by unscrewing the four screws.



4. Disconnect the cables from the front lights.
5. Dismantle the inner front cover by unscrewing the four screws.

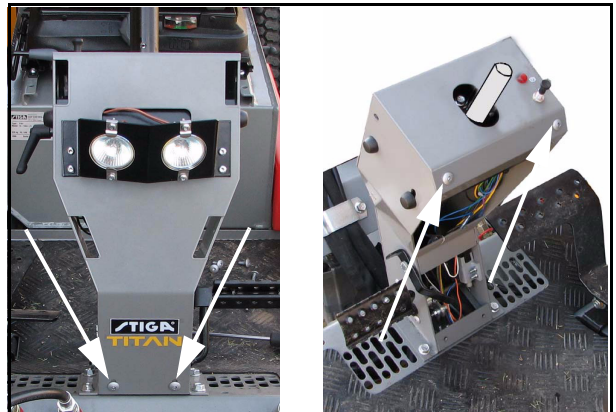

Edition	Manual	Chapter	Page
2008-10-17	Workshop Manual, Stiga Titan	3 Steering	4

6. Mark up the five hydraulic hoses, connected to the underside of the steering servo.

The letters in the figure are stamped in the bottom of the cylinder close to the actual port.

7. Loosen and disconnect the hoses.

8. Disassemble the steering servo by unscrewing the four upper screws (A).

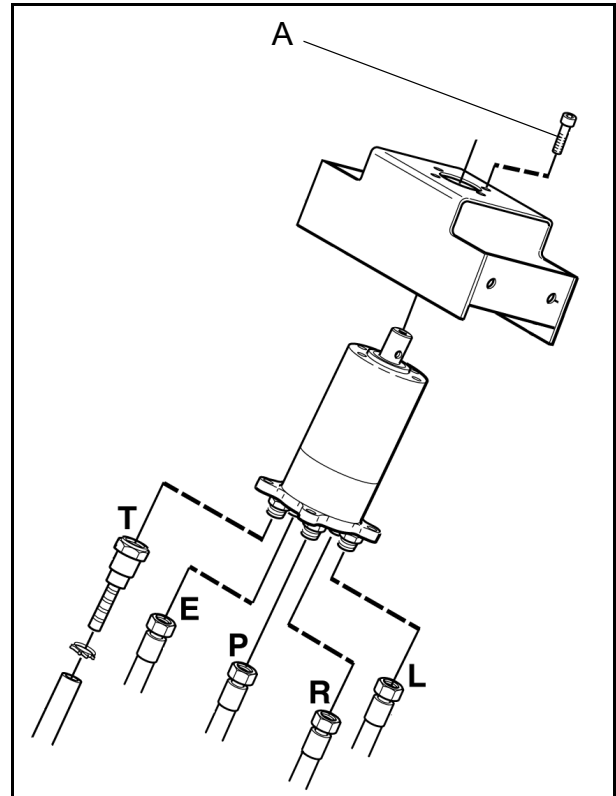

3.1.2 Repair of the steering servo

The only repair which can be actual at the steering servo is changing of the O-rings. See section 4.

3.1.3 Assembly the steering servo

1. Assemble the steering servo in the reverse order.

Be sure to connect the hydraulic hoses to their desired places, marked during the disassembly.

The system will be automatic bled after a few steering attempts.

Check after the assembly that no oil leakage exists.

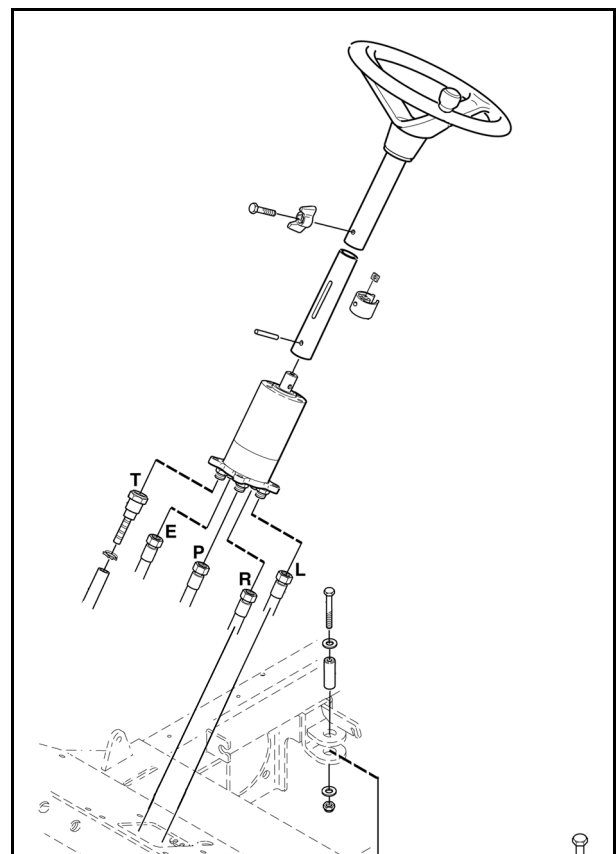

Edition	Manual	Chapter	Page
2008-10-17	Workshop Manual, Stiga Titan	3 Steering	5

3.1.4 Trouble shooting

One prerequisite for the function of the power assisted steering is the play in the steering. This play must always spring back to the starting position when the wheel is released.

Test by slowly turning the wheel in one direction when the engine is switched off. At first there is a slight resistance, which increases when the machine begins to turn. Release the wheel. It should now return to the middle position.

The wheel should spring back approx. 10-20 mm when the wheel is released after turning. However, the machine will not automatically “drive straight forward” after turning in the same way as a car.

If the machine always turns in the same direction as soon as the engine is started, there is probably a fault in the torque converter.

Another conceivable fault can be that the bearing in the steering column tube is jamming, so that the steering wheel cannot automatically return to the neutral position.



Note!

If the steering does not function this does not mean that there is always a fault in the torque converter. Faults can also occur in more simple mechanical parts such as chains and gear wheels.



Edition	Manual	Chapter	Page
2008-10-23	Workshop Manual, Stiga Titan	4 Hydraulic system	1

4 Hydraulic system

Contents in this chapter

4.1 Safety	1	4.6.1 Physic description	26
4.2 Configuration	2	4.6.2 Functional description	28
4.3 Description of driving system ..	3	4.7 Trouble shooting	31
4.3.1 Physic description	3	4.7.1 Drive system.....	31
4.3.2 Functional description	6	4.7.2 External hydraulics	32
4.4 Description of steering system	10	4.8 Repair	35
4.4.1 Physic description	10	4.8.1 Changing hydraulic oil, filter ...	35
4.4.2 Functional description	12	4.8.2 Hydraulic oil level indicator	36
4.5 Description of hydr. outputs	15	4.8.3 Disassembly the hydr pumps .	36
4.5.1 Using the hydraulic outputs....	15	4.8.4 Disassembly the PTO pump... 38	
4.5.2 Physic description	16	4.8.5 Changing O-rings st servo.....	39
4.5.3 Functional description	18	4.8.6 Changing O-rings hydr cyl.....	41
4.6 Description of PTO drive	26	4.9 Adjustments	43
		4.9.1 Press. PTO drive, 26H, 26HS	43

General

The four wheel drive Titan machines are equipped with hydraulic power transmission. I.e. the engine drives an hydraulic pump, which pumps oil through the rear and front wheel motors. There are two main configurations; Belt driven PTO and hydraulic driven PTO.

The front axle and rear motors are connected in series, which means that the front wheels and rear wheels are forced to rotate at the same speed. This configuration gives a built in differential function which make turning easier.

The machines are also equipped with hydraulic assisted steering, hydraulic implement lifter and auxiliary hydraulic functions.

This chapter contains a description of the hydraulic system, trouble shooting to isolate faults and information about adjustments and corrective measures.

4.1 Safety

Hydraulic oil under pressure can be very dangerous if hoses, lines or other distribution parts are leaking. To avoid personal injuries, always wear protection gloves and protection goggles during works with the hydraulic system.

Before starting the motor, place the machine outdoors or install an extraction device for the exhaust fumes. Otherwise the personel will be poisoned.

Cleanliness is mandatory at all works with the hydraulic system. Foreign substances and contaminations will jeopardize the function and reliability of the system. Always protect and close openings of hoses, lines and connections when replacing components.

Edition	Manual	Chapter	Page
2008-10-23	Workshop Manual, Stiga Titan	4 Hydraulic system	2

4.1 Configuration

There are two main configurations of the Titan machines, depending on the PTO drive, belt or hydraulic. Machines with belt driven PTO have a “B” in their denomination and machines with hydraulic driven PTO have a “H” in their denomination.

Machines with belt driven PTO are equipped with two main hydraulic systems:

- Driving system
- External hydraulics

Machines with hydraulic driven PTO are equipped with three main hydraulic systems:

- Driving system
- External hydraulics
- PTO drive

These systems work with the same oil, but in separate parallel systems. Each system has its own separate hydraulic pump.

The driving system pressure is depending on the power requirements at the wheel axles and is limited by the engine power.

The PTO drive system pressure is depending on the power requirements in the implement and is limited to 220 bar.

The external hydraulics is limited to 125 bar and is divided in the following items:

- Two outputs front for implement functions. The outputs are double acting.
- Machines with hydraulic driven PTO; One output rear, parallel connected to the right located output above.
- Implement lifter, double acting.
- Hydraulic assisted steering.

Edition	Manual	Chapter	Page
2008-10-23	Workshop Manual, Stiga Titan	4 Hydraulic system	3

4.2 Description of driving system

4.2.1 Physic description

General

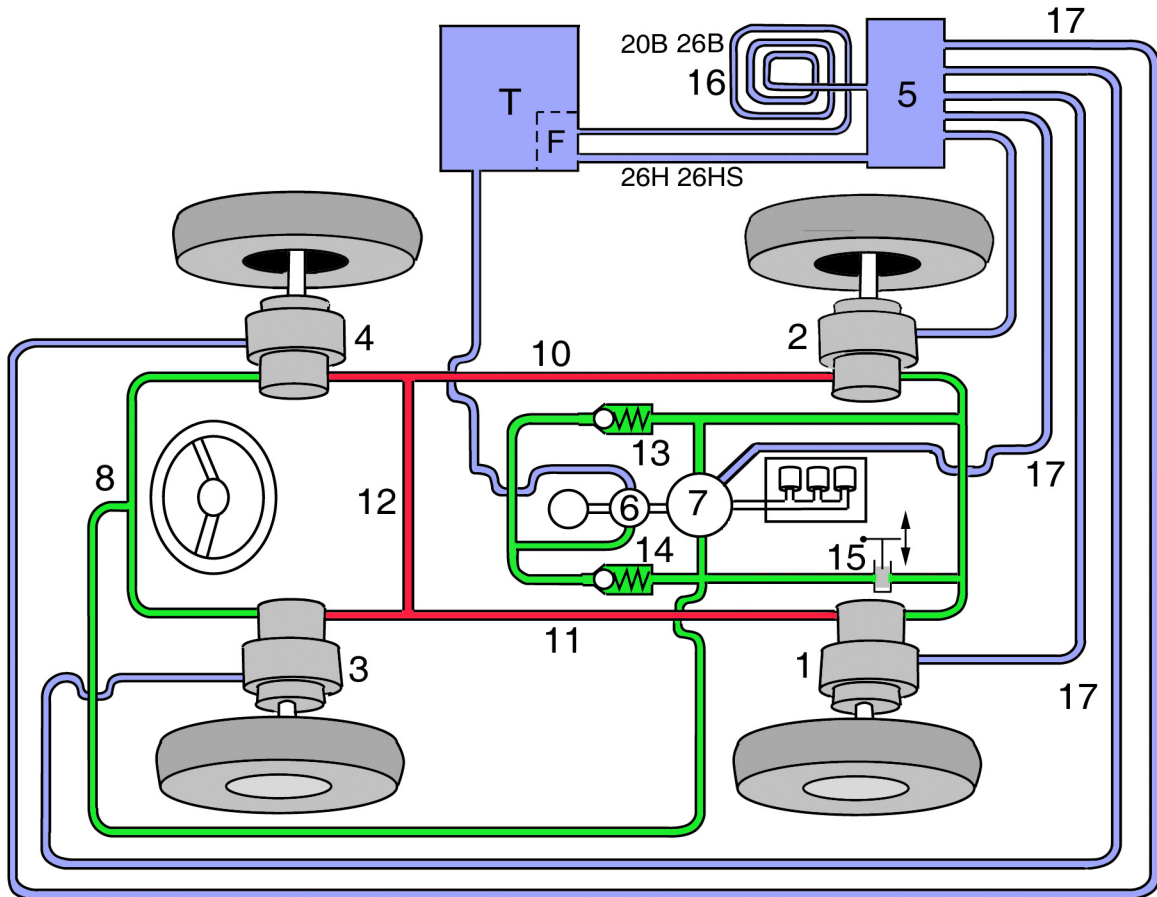

1. Wheel motor, rear left.
2. Wheel motor, rear right.
3. Wheel motor, front left.
4. Wheel motor, front right.
5. Collector block.
6. Feeding pump.
7. Main pump.
8. Main flow line (reverse driving).
9. Main flow line (forward driving).
10. Main flow line (between right motors).
11. Main flow line (between left motors).
12. By-pass line, front axle.
- 13 + 14. Non return valves.
15. By-pass valve.

16. Cooler (only 20B, 26B)

17. Leak flow line.

F. Tank filter.

T. Tank

Colour - Pressure

— Red is the working pressure to the hydraulic motors.

— Green is the feeding pressure to the main pump. Green lines can act both as pressure lines and return lines, depending on the driving direction.

— Blue is the atmospheric pressure in the oil container and housings.

Edition	Manual	Chapter	Page
2008-10-23	Workshop Manual, Stiga Titan	4 Hydraulic system	4

Wheel motors

Each wheel motor consists of a hydraulic motor and a reduction planetary gear.

The ratio in the planetary gear is 12.5:1.
The oil consumption is 162 cc per wheel turn.

The planetary gear is lubricated with oil. The oil shall be changed first time after 50 hours of operation and thereafter with 200 hours of operation interval.

Oil quality: Gear oil SAE50

Oil volume: 0,2 l

The physical parts of the wheel motors are as follows:

1. Hole for lifting eye.
2. Hydraulic motor
3. Main ports, upper.
4. Parking brake lever. Only front motors.
5. Wheel axle.
6. Planetary reduction gear.
7. Filling/level plug for reduction planetary gear.
8. Drain plug plug for reduction planetary gear.
9. Drain port, hydraulic motor.
10. Main ports, lower.

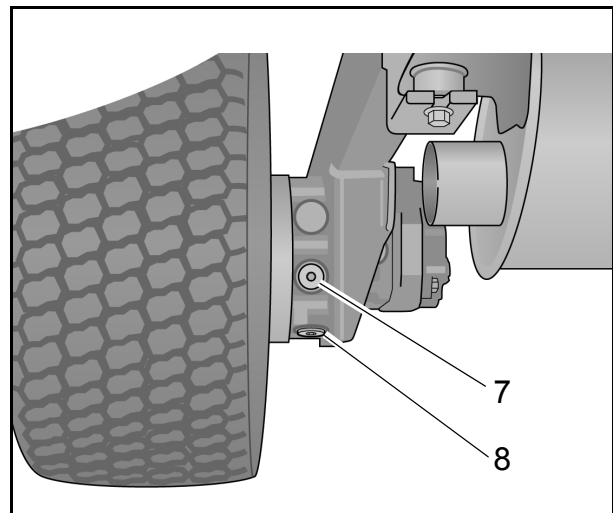
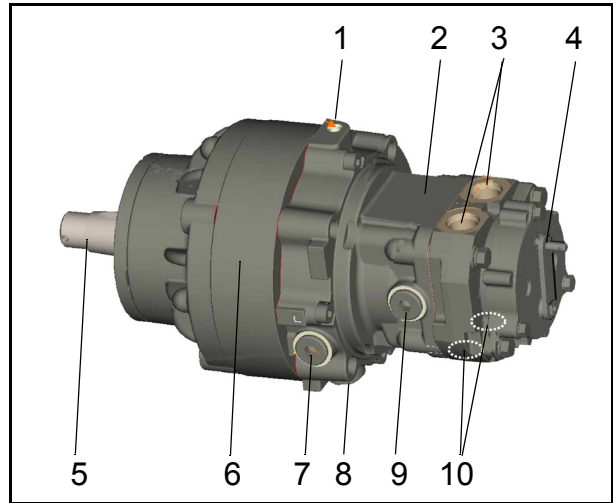

Shoe configuration

There are two configurations in contact between the pistons and the tilted disc:

- Without shoes (A)
- With shoes (B)

The configuration with shoes gives longer duration time, but somewhat lower starting torque.

Wheel motor configurations:

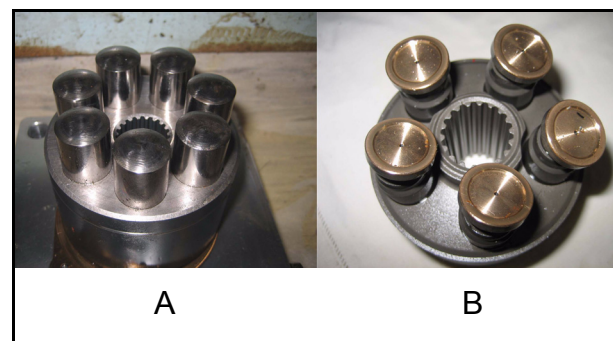

	20B	26B	26H	26HS
Front motors	A	A	B	B
Rear motors	B	B	B	B

Edition	Manual	Chapter	Page
2008-10-23	Workshop Manual, Stiga Titan	4 Hydraulic system	5

Hydraulic pumps

There are three hydraulic pumps, built together into one unit:

- Main pump for the driving system (13).
- Charge pump for the main pump (12).
- Pump for the external hydraulics (11). This pump belongs not to the driving system. See "10" and "15".

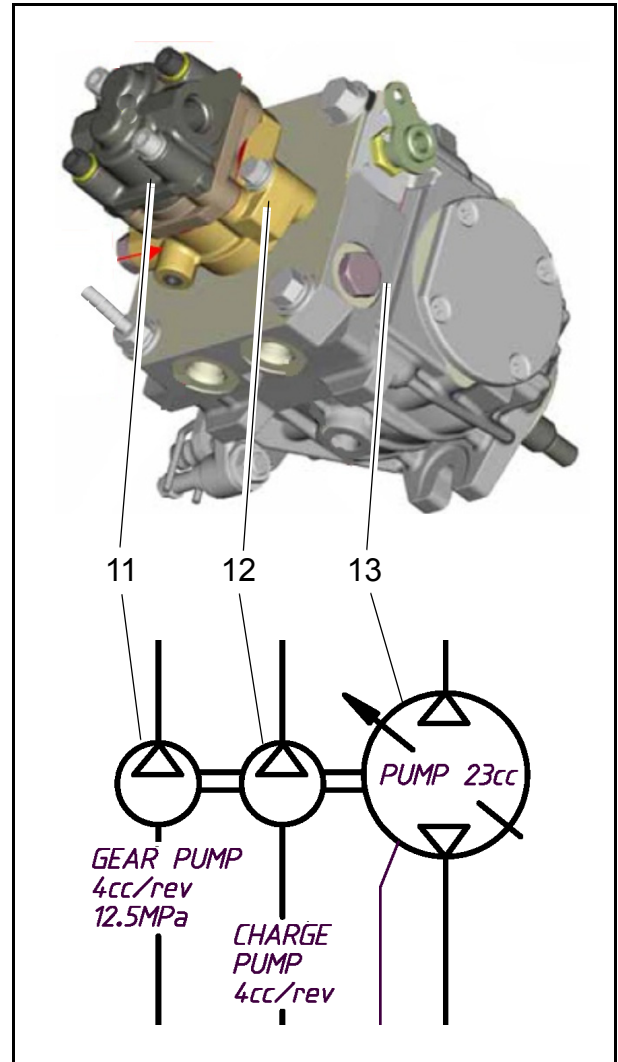

Edition	Manual	Chapter	Page
2008-10-23	Workshop Manual, Stiga Titan	4 Hydraulic system	6

4.2.2 Functional description

Driving forward

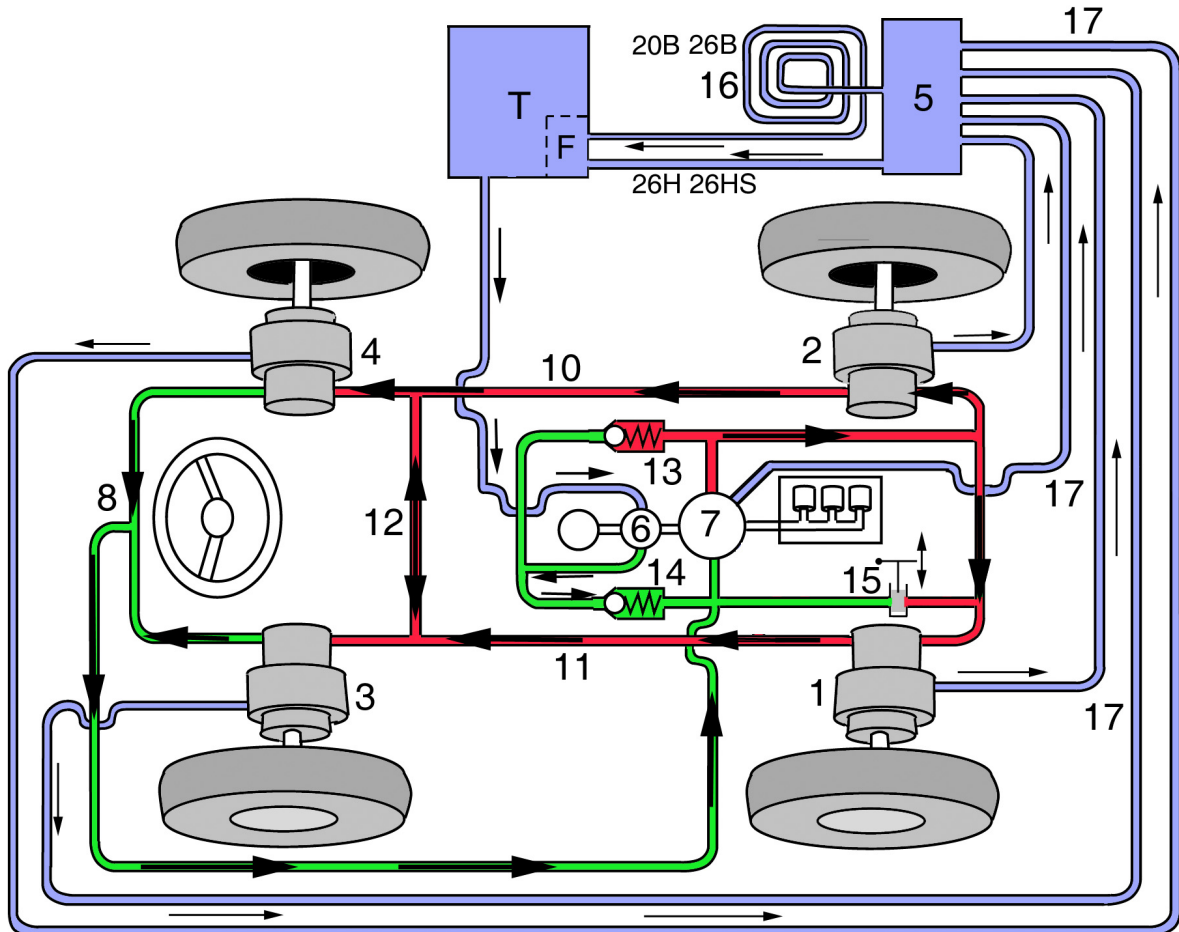

1. Wheel motor, rear left.
2. Wheel motor, rear right.
3. Wheel motor, front left.
4. Wheel motor, front right.
5. Collector block.
6. Feeding pump.
7. Main pump.
8. Main flow line (reverse driving).
9. Main flow line (forward driving).
10. Main flow line (between right motors).
11. Main flow line (between left motors).
12. By-pass line, front axle.
- 13 + 14. Non return valves.
15. By-pass valve.

16. Cooler (only 20B, 26B).

17. Leak flow line.

F. Tank filter.

T. Tank.

Colour - Pressure

Red is the working pressure to the hydraulic motors.

Green is the feeding pressure to the main pump.

Blue is the atmospheric pressure in the oil container and housings.

Edition	Manual	Chapter	Page
2008-10-23	Workshop Manual, Stiga Titan	4 Hydraulic system	7

Driving backwards

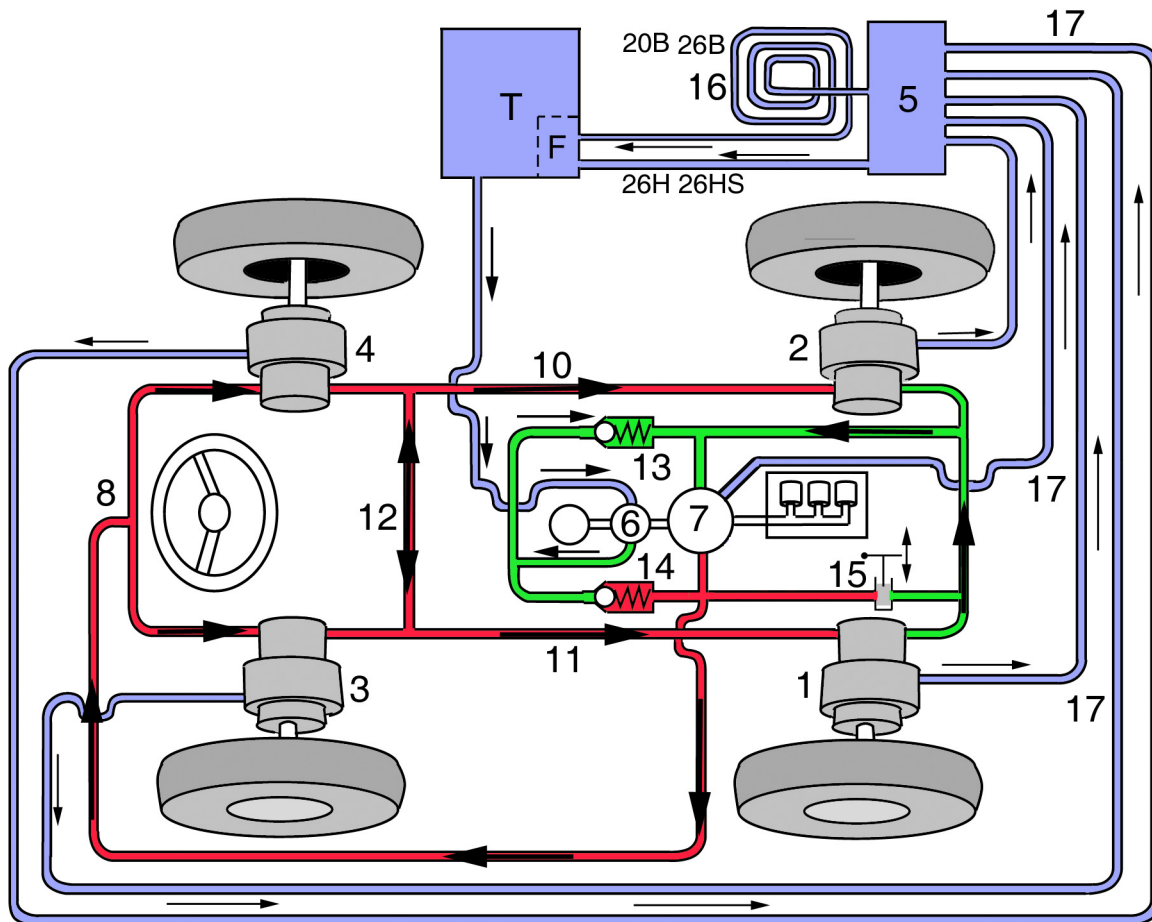

1. Wheel motor, rear left.
2. Wheel motor, rear right.
3. Wheel motor, front left.
4. Wheel motor, front right.
5. Collector block
6. Feeding pump.
7. Main pump.
8. Main flow line (reverse driving).
9. Main flow line (forward driving).
10. Main flow line (between right motors).
11. Main flow line (between left motors).
12. By-pass line, front axle.
- 13 + 14. Non return valves.
15. By-pass valve.

16. Cooler (only 20B, 26B)

17. Leak flow line.

F. Tank filter.

T. Tank

Colour - Pressure

Red is the working pressure to the hydraulic motors.

Green is the feeding pressure to the main pump.

Blue is the atmospheric pressure in the oil container and housings.



Edition	Manual	Chapter	Page
2008-10-23	Workshop Manual, Stiga Titan	4 Hydraulic system	8

Drive description

The charge pump (6) and the main pump (7) are integrated into one unit together with the external hydraulics pump. The pump unit is integrated to the engine.

The engine drives the the hydraulic pump unit with a constant speed. The charge pump (6) is feeding the main pump (7) with 2,5 bar through the non-return valves (13 and 14). This pressure is limited by a pressure valve (integrated in the pump, and not shown). The pressure valve is factory set and not adjustable. The oil, fed into the main pump during operation, is a replacement for the leak oil from the wheel motors (A and B) and the main pump (2). Such the charge pump always ensures a pressure of 2,5 bar at the main pump suction side.

The charge pump sucs its oil direct from the oil tank (T).

The oil flow and the flow direction through the main pump (7) and the wheel motors (1, 2, 3, and 4) - is controlled by the drive pedal, mechanical connected to the main pump (7). The main pump pressure is depending on the power requirements at the wheels and is limited by the engine power.

Leak oil

The wheel motors and the hydraulic pump have a small oil leakage (1-4%), which increases with increased power requirement (increased pressure). The leakage oil is collected inside the unit housings and forwarded to the collector block back to the oil tank through the leak flow lines (17). The charge pump (6) compensates for this leakage.

Drive priority

The motors on the same shaft are connected in parallel, after that, the front wheel motors are are connected in serie with the rear wheel motors first, when driving forwards. This means, due to the leakage in the rear motor, that the machine under normal conditions drives on the rear wheels only. When the rear wheels begin to slip (rotate with 1-4% higher speed than the front wheels) also the front wheels start to drive and the slipping is avoided. This fact is not noticed by the operator, since the machine is driven with its four wheels after demand.

Shunt line (differential)

The above discussions include a shunt line (12), connected between the front motor connection lines (10 and 11). This shunt line allow all wheels to rotate with different speeds. This is necessary during rotating the steering wheel.

Edition	Manual	Chapter	Page
2008-10-23	Workshop Manual, Stiga Titan	4 Hydraulic system	9

Using the by-pass function

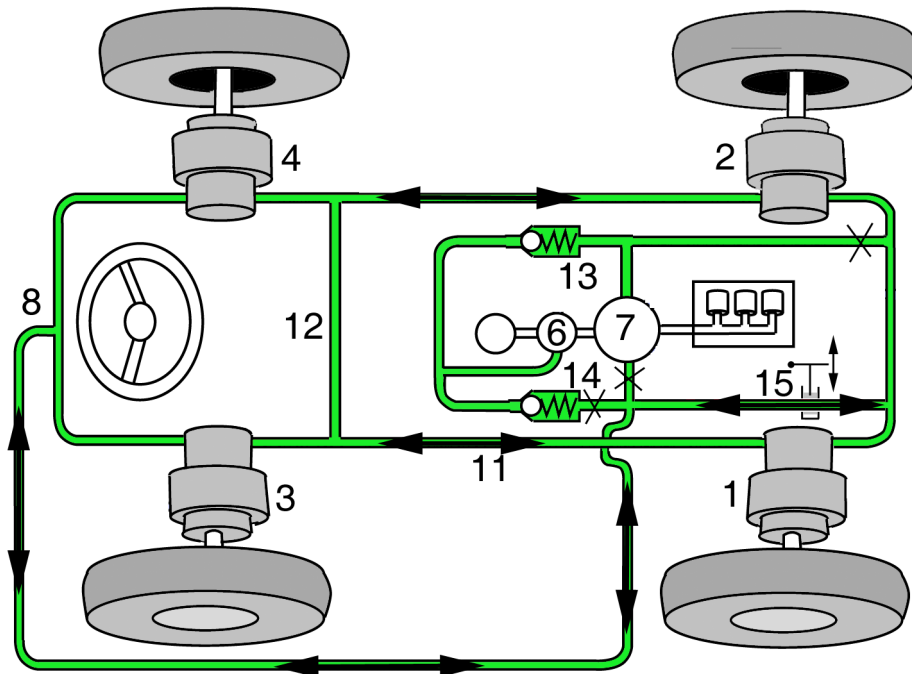

- | | |
|--------------------------------------|--|
| 1. Wheel motor, rear left. | 9. Main flow line (forward driving). |
| 2. Wheel motor, rear right. | 10. Main flow line (between right motors). |
| 3. Wheel motor, front left. | 11. Main flow line (between left motors). |
| 4. Wheel motor, front right. | 12. By-pass line, front axle. |
| 7. Main pump. | 15. By-pass valve. |
| 8. Main flow line (reverse driving). | |

By pass valve

In parallel with the drive lines there is a by-pass valve (15) connected. When the by-pass valve is opened (inwards), the oil will pass the valve instead of the pump. Oil will not flow where the crosses are located in the figure.

The purpose of the by-pass valve is to disable the resistance in the main pump and allow the oil to circulate in the system when the wheels need to be turned. However, when the by-pass valve is actuated the resistance in the system is still not zero, why it is only allowed to push the machine short distances, i.e. up on a trailer.

Edition	Manual	Chapter	Page
2008-10-23	Workshop Manual, Stiga Titan	4 Hydraulic system	10

4.3 Description of steering system

4.3.1 Physic description

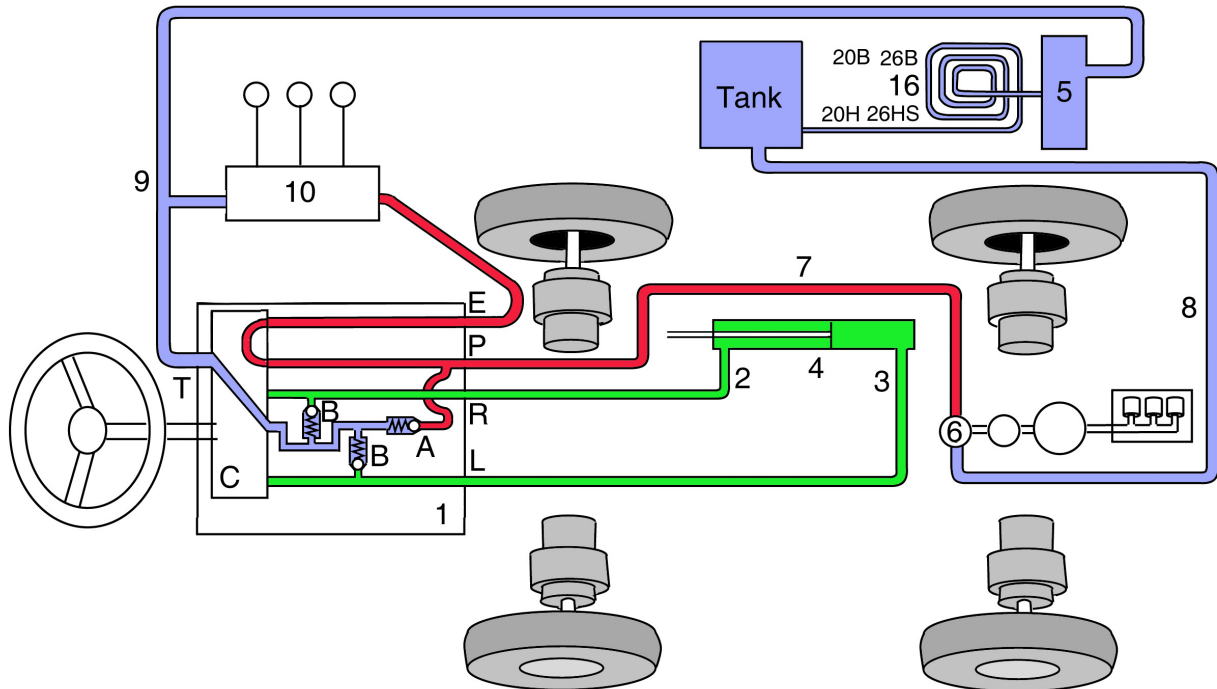

1. Steering servo including the following:
 - A. Pressure limiting valve
 - B. Chock valves
 - C. Steering unit
- Terminals at the steering servo:
 - P. Unregulated inlet from the hydraulic pump for external hydraulics.
 - T. Outlet to the tank for leak oil and oil from the passive side of steering cylinder when turning.
 - E. Outlet to other external hydraulics.
 - L. Outlet to the steering cylinder. Pressure when turning left.
 - R. Outlet to the steering cylinder. Pressure when turning right.

- 2, 3. Pressure lines to transmit the steering power.

4. Steering cylinder.
5. Collector block.
6. Pump for external hydraulics, integrated to the driving pumps.
7. Pressure line.
8. Suction line.
9. Leak flow line and return line.
10. External hydraulics.
16. Cooler (only 20B, 26B)

Colour - Pressure

Red is the feeding pressure to the steering servo and external hydraulics.

Blue is the atmospheric pressure in the oil container and lines.

Green lines can act both as pressure lines and return lines, depending on the movements.



Edition	Manual	Chapter	Page
2008-10-23	Workshop Manual, Stiga Titan	4 Hydraulic system	11

1. Steering servo

The steering servo is a complete unit. The steering servo transmits the oil flow to the external hydraulics. The valves in the steering servo are not adjustable. The steering servo has 5 hydraulic terminals at its underside. The following items are included in the steering servo:

A. Pressure limiting valve

The pressure limiting valve (A) is set to 125 bar. That means that the pressure in the steering system and in the external hydraulics never can exceed 125 bar.

B. Chock valves

The chock valves are intended to reduce the pressure in the pressure liner (2 and 3) if a sudden obstacle or blocking occurs during the driving.

C. Steering unit

The steering unit has a built in attribute to always give priority to the steering function in cases when the steering and external hydraulics are used at the same time.

4. Steering cylinder

The steering cylinder is connected to the front and rear frame at the right side of the machine. By expanding respective retracting it brings the frames to angle into desired directions.

5. Collector block

The collector block collects leak oil and return oil from all hydraulic components to transit it back to the tank.

Edition	Manual	Chapter	Page
2008-10-23	Workshop Manual, Stiga Titan	4 Hydraulic system	12

4.3.2 Functional description

Not turning, steering wheel not actuated

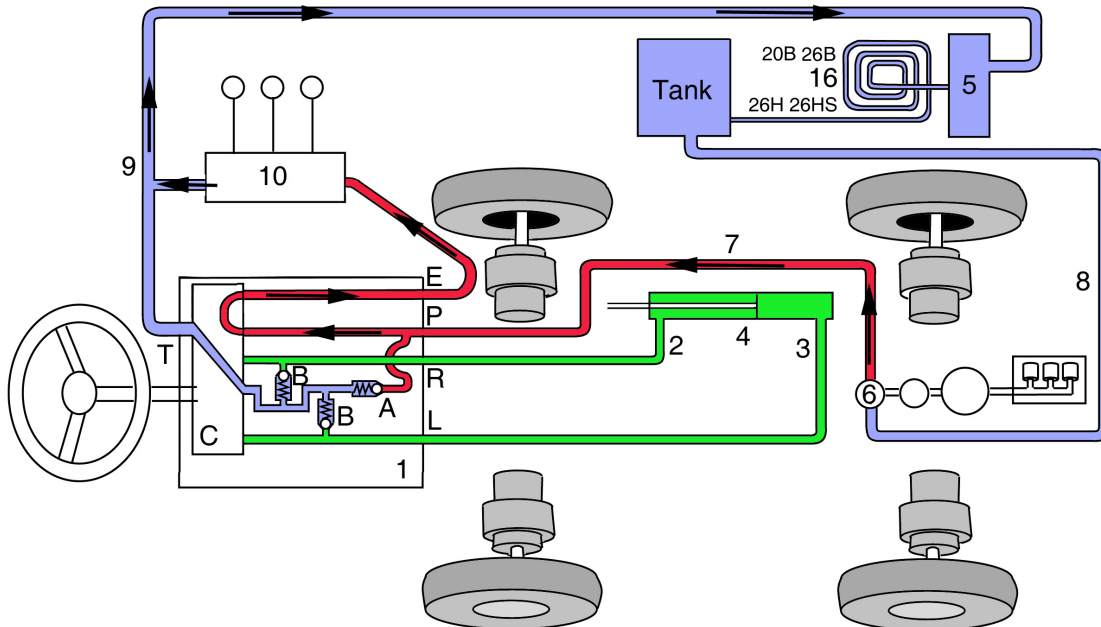

1. Steering servo including the following:
 - A. Pressure limiting valve
 - B. Chock valves
 - C. Steering unit
5. Collector block.
6. Pump for external hydraulics, integrated to the driving pumps.
7. Pressure line.
8. Suction line.
9. Leak flow line and return line.
10. External hydraulics.

Terminals at the steering servo:

- P. Unregulated inlet from the hydraulic pump for external hydraulics.
- T. Outlet to the tank for leak oil and oil from the passive side of steering cylinder when turning.
- E. Outlet to other external hydraulics.

Colour - Pressure

- Red is the feeding pressure to the steering servo and external hydraulics.
- Blue is the atmospheric pressure in the oil container and lines.
- Green lines can act both as pressure lines and return lines, depending on the movements.

The pump (6) is sucking oil from the tank and pumping it into the steering servo. Since the steering is not in use, the oil flows without resistance through the steering servo, steering unit and to the external hydraulics. If the external hydraulics is in use, the pressure limit valve (A) will reduce the pressure to 125 bar. From the external hydraulics, the oil is flowing back to the tank via the collector block 5 and at belt machines also via the cooler (16).

Edition	Manual	Chapter	Page
2008-10-23	Workshop Manual, Stiga Titan	4 Hydraulic system	13

Turning to the left

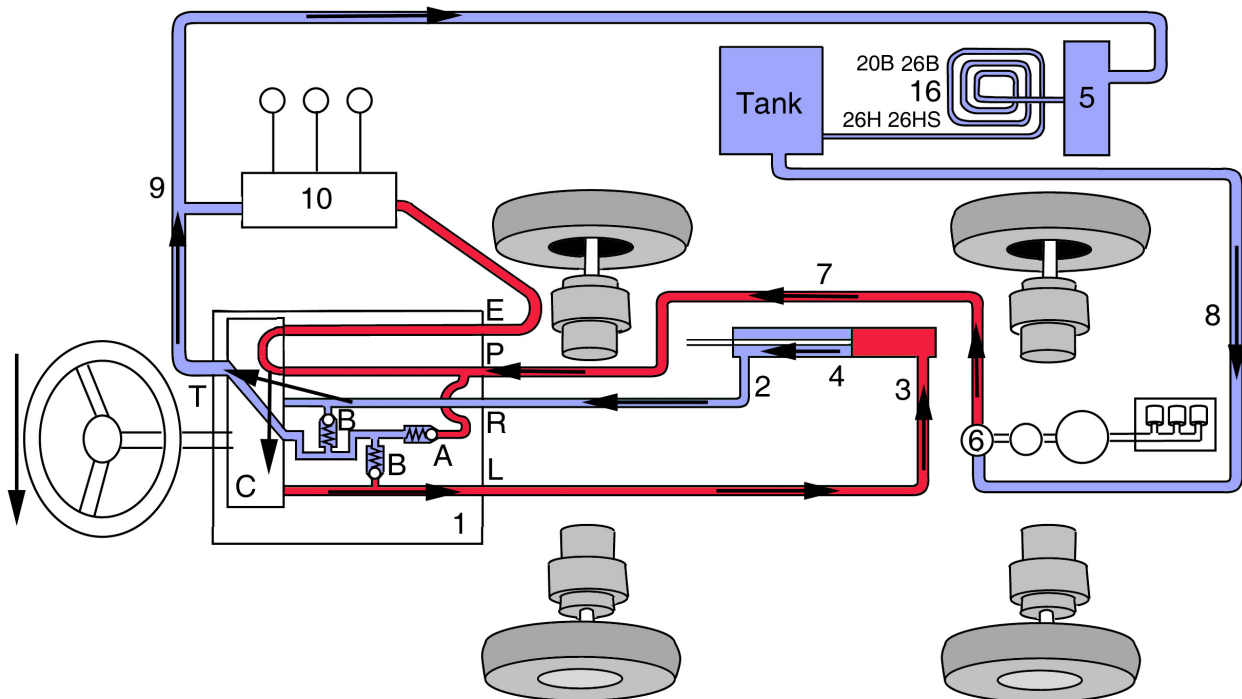

1. Steering servo including the following:
 - A. Pressure limiting valve
 - B. Chock valves
 - C. Steering unit

Terminals at the steering servo:

 - P. Unregulated inlet from the hydraulic pump for external hydraulics.
 - T. Outlet to the tank for leak oil and oil from the passive side of steering cylinder when turning.
 - E. Outlet to other external hydraulics.
 - L. Outlet to the steering cylinder. Pressure when turning left.
 - R. Outlet to the steering cylinder. Pressure when turning right.
- 2, 3. Pressure lines to transmit the steering power.

4. Steering cylinder.
5. Collector block.
6. Pump for external hydraulics, integrated to the driving pumps.
7. Pressure line.
8. Suction line.
9. Leak flow line and return line.
10. External hydraulics.
16. Cooler (only 20B, 26B)

Colour - Pressure

- Red is the feeding pressure to the steering servo and external hydraulics.
- Blue is the atmospheric pressure in the oil container and lines.
- Green lines can act both as pressure lines and return lines, depending on the movements.

Edition	Manual	Chapter	Page
2008-10-23	Workshop Manual, Stiga Titan	4 Hydraulic system	14

Turning to the right

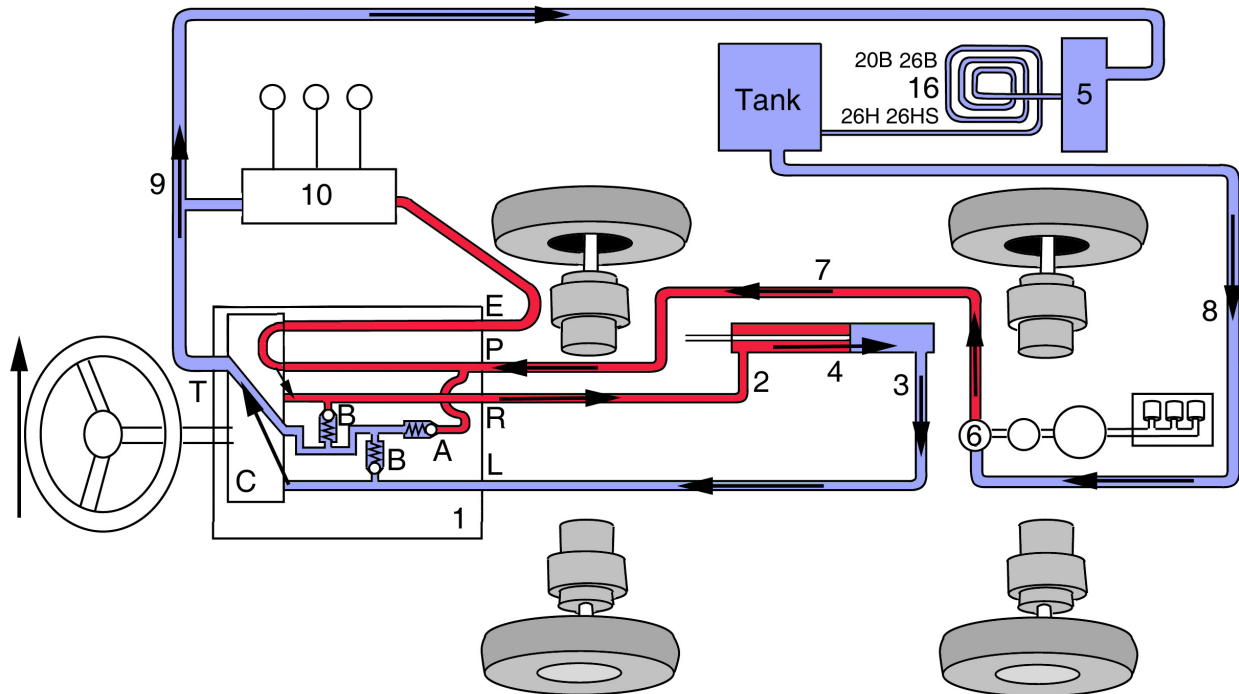

1. Steering servo including the following:
 - A. Pressure limiting valve
 - B. Chock valves
 - C. Steering unit

Terminals at the steering servo:

 - P. Unregulated inlet from the hydraulic pump for external hydraulics.
 - T. Outlet to the tank for leak oil and oil from the passive side of steering cylinder when turning.
 - E. Outlet to other external hydraulics.
 - L. Outlet to the steering cylinder. Pressure when turning left.
 - R. Outlet to the steering cylinder. Pressure when turning right.
- 2, 3. Pressure lines to transmit the steering power.

4. Steering cylinder.
5. Collector block.
6. Pump for external hydraulics, integrated to the driving pumps.
7. Pressure line.
8. Suction line.
9. Leak flow line and return line.
10. External hydraulics.
16. Cooler (only 20B, 26B)

Colour - Pressure

Red is the feeding pressure to the steering servo and external hydraulics.

Blue is the atmospheric pressure in the oil container and lines.

Green lines can act both as pressure lines and return lines, depending on the movements.

Edition	Manual	Chapter	Page
2008-10-23	Workshop Manual, Stiga Titan	4 Hydraulic system	15

4.4 Description of hydraulic outputs

4.4.1 Using the hydraulic outputs

Implement lifter (F1)

The hydraulic implement lifter only works when the engine is running. However, it can be lowered to the floating position when the engine is off.



Never leave the machine with the implement in the transport position. Risk of serious crushing injuries by the implement as it lowers quickly if the control is unintentionally affected.

The lever has the four following positions:



Floating position. Move the lever to its front position, where it locks. The implement is now lowered to its floating position. Also see "15".

In the floating position, the implement always rests against the ground at the same pressure and can follow the contours of the ground.

Use the floating position when carrying out work.



Lowering. The implement lowers regardless of its weight. The lowering speed can be set using the control (4). The lowering force is determined by the implement's weight and the hydraulic down force that is applied when lowering.



Locking in the transport position. The lever has returned to the neutral position after raising and lowering. The implement is locked in the transport position.



Raising. Move the lever to the rear position until the implement is in the highest position (transport position). Then release the lever to lock in the transport position.

Check valve lowering (4)

The check valve regulates the speed when lowering. The speed must be adjusted according to the weight of the actual implement.

Increasing the lowering speed:

Undo the nut and turn the knob to the left.

Reducing the lowering speed:

Undo the nut and turn the knob to the right.

The check valve must be locked in the set position with the nut.

4.4.2 Physic description

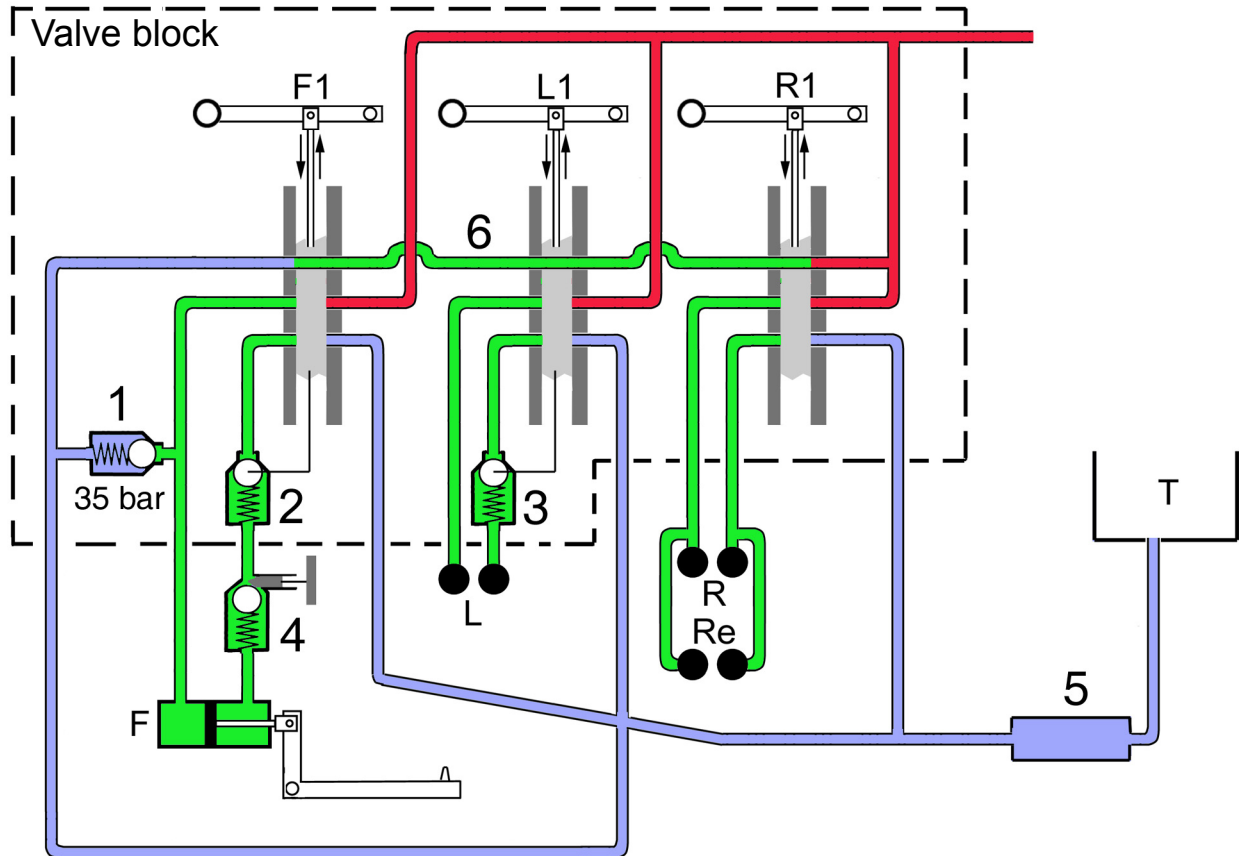

- F. Implement lifter cylinder
- F1. Control lever for the implement lifter F.
- L. Hydraulic output front, left at B-machines and middle at H-machines.
- L1. Control lever for the hydraulic output L.
- R. Hydraulic outputs front, right.
- Re. Hydraulic outputs rear.
- R1. Control lever for the hydraulic outputs R and Re.
- T. Tank

- 1. Pressure limiting valve.
- 2. Mechanic actuated non-return valve.
- 3. Mechanic actuated non-return valve.
- 4. Check valve lowering.
- 5. Collector block

Colour - Lines

- Red is the feeding pressure lines to the external hudraulics.
- Blue is the return lines with atmospheric pressure.
- Green lines can act both as pressure lines and return lines, depending on the implement movement.

See also next page regarding locations on the machine and further descriptions of the components.

Edition	Manual	Chapter	Page
2008-10-23	Workshop Manual, Stiga Titan	4 Hydraulic system	17

Location of actuators and hydraulic outputs at the machine

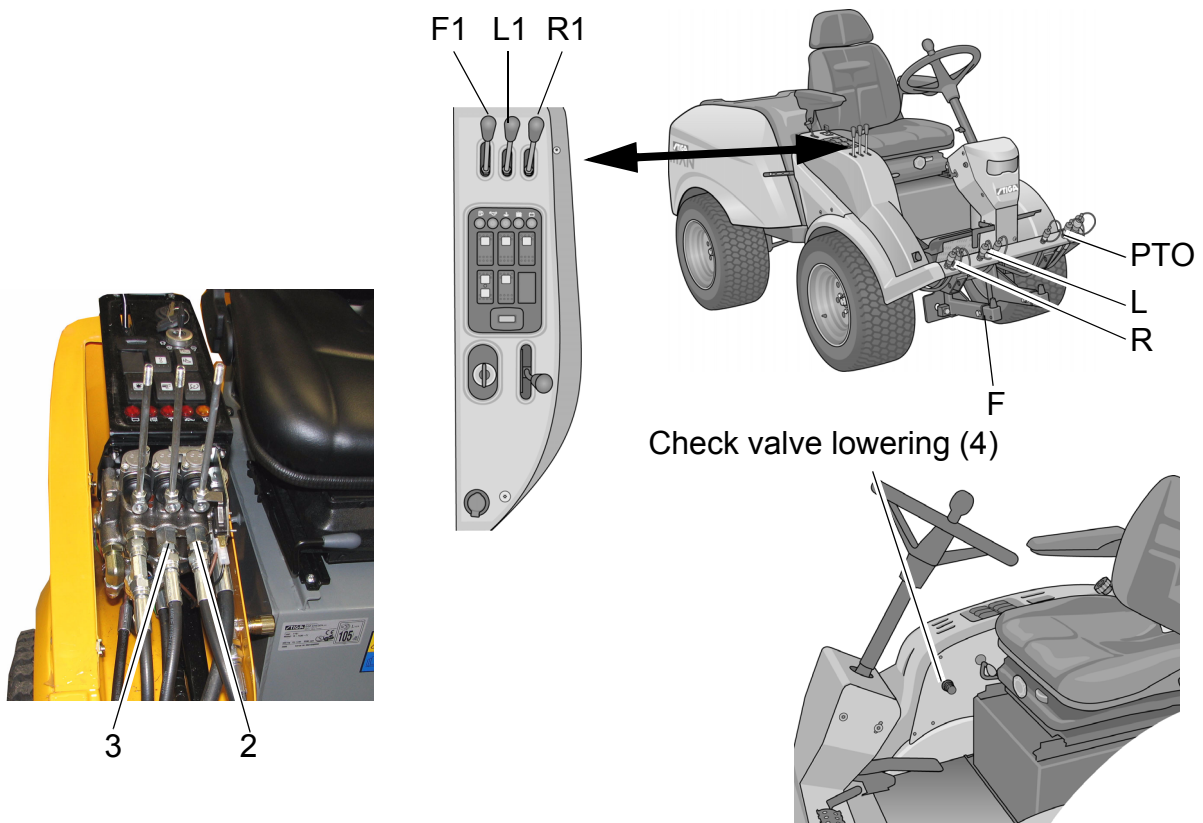

Description of components

1. Pressure limiting valve

This valve is intended to reduce the pressure when the implement lifter is forced downwards. Otherwise the implement will be damaged and the machine would have a tendency to rise at the front.

2 and 3. Mechanic actuated non-return valve

The valves F1 and L1 have a small oil return leakage. To prevent the implement moving due to its own weight, the oil flow is stopped by these valves. To facilitate the flow when the implement shall move in this direction, the valves are mechanical affected of the valve slide to open.

4. Check valve lowering

This valve is adjustable and its purpose is to reduce the oil flow, and thus adapt the speed to implements with different weights, when the implement lifter is lowering.

5. Collector block

The collector block collects leak oil and return oil from all hydraulic components to transit it back to the tank.

4.4.3 Functional description

External hydraulics not in use

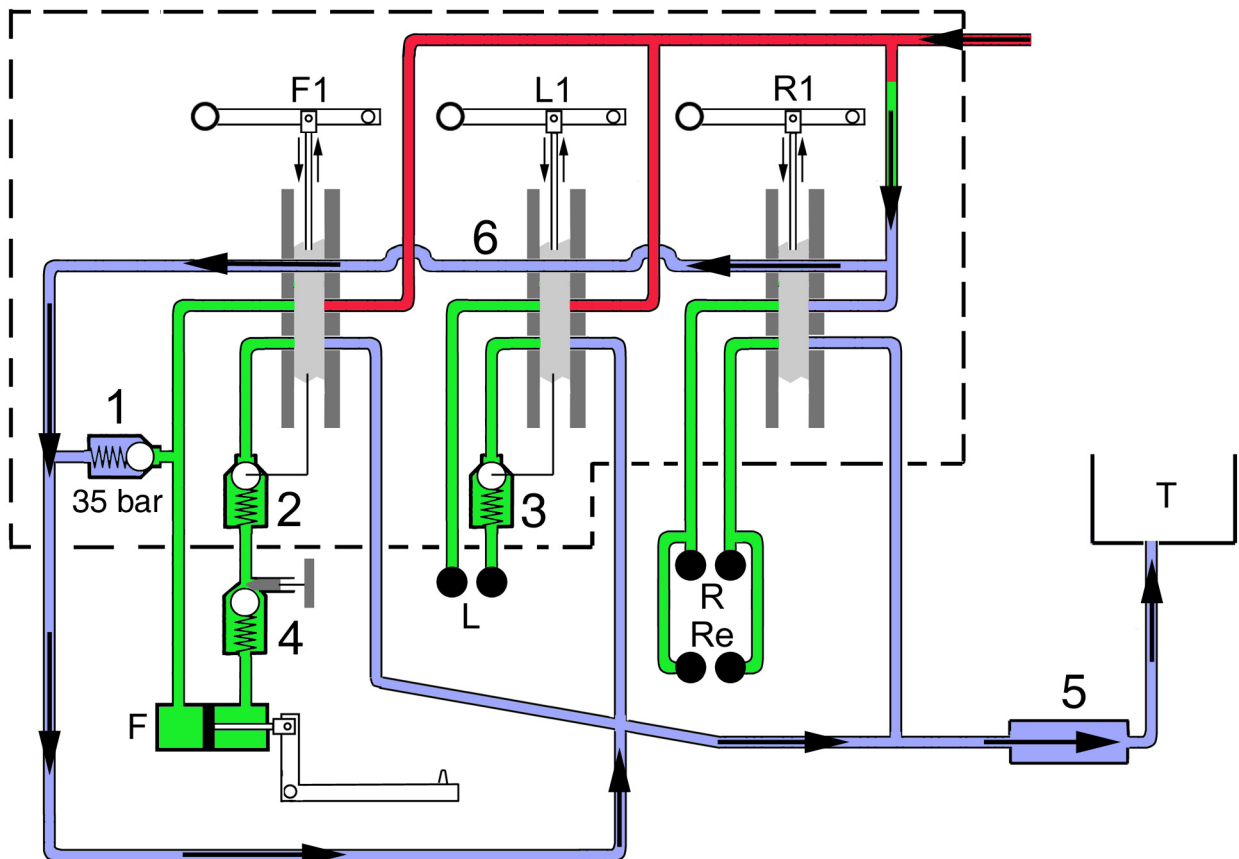

- F1. Control lever for the implement lifter F.
- L1. Control lever for the hydraulic output L.
- R1. Control lever for the hydraulic outputs R and Re.
- T. Tank
- 5. Collector block
- 6. By pass line

Colour - Lines

- Red is the feeding pressure lines to the external hydraulics.
- Blue is the return lines with atmospheric pressure.
- Green lines can act both as pressure lines and return lines, depending on the implement movement.

Oil flows from the steering unit, through the by pass line 6.

The oil is then flowing back to the tank via the collector block.

Edition	Manual	Chapter	Page
2008-10-23	Workshop Manual, Stiga Titan	4 Hydraulic system	19

Implement lifter upwards

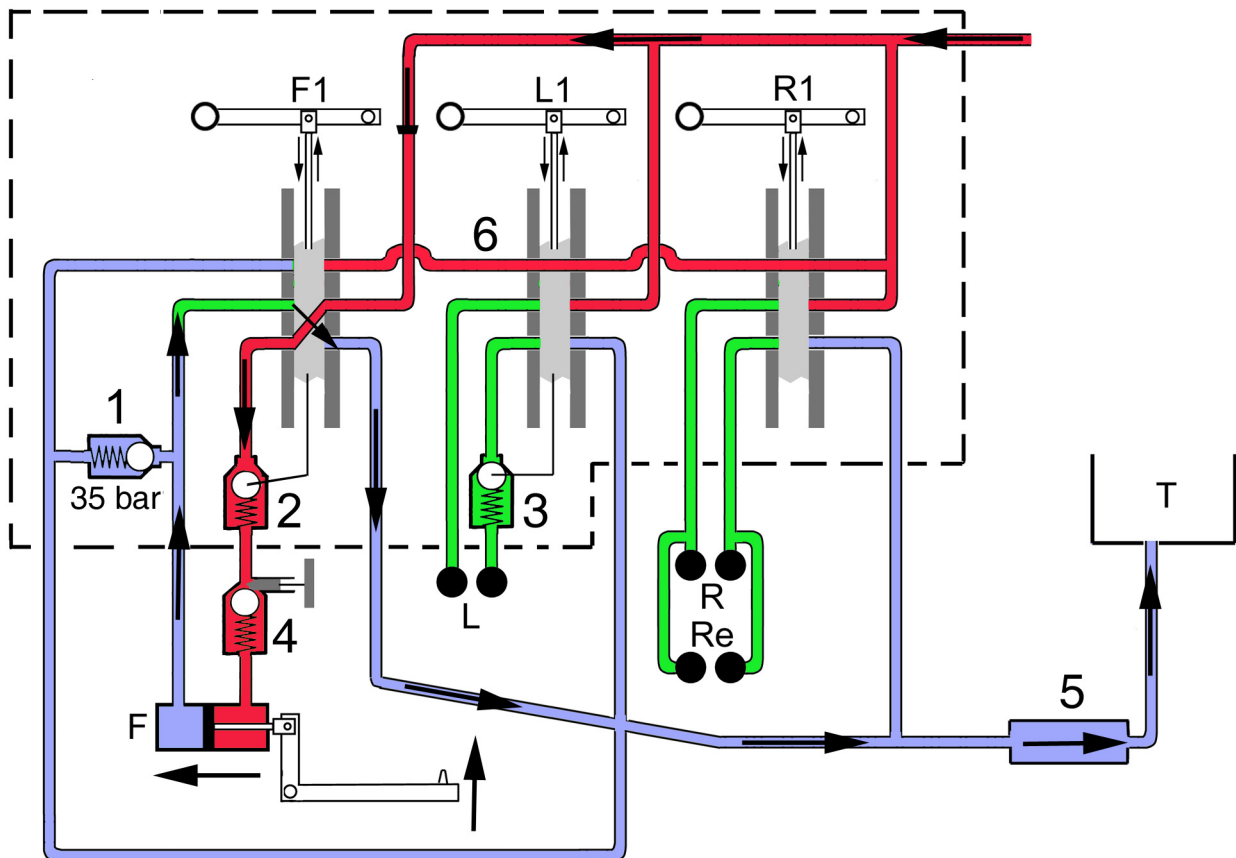

F. Implement lifter cylinder.

F1. Control lever for the implement lifter F.

T. Tank

2. Mechanic actuated non-return valve.

4. Check valve lowering.

5. Collector block

6. By pass line

The by pass line is blocked in valve F1.

Oil flows from the steering unit, through the valve F1. The valves 2 and 4 become fully open.

The piston in cylinder F is pressed against its bottom and the lifter rises.

The oil in the opposite side of the piston is pressed back to the tank via valve F1 and the collector block.

Colour - Lines

Red is the feeding pressure lines to the external hydraulics.

Blue is the return lines with atmospheric pressure.

Green lines can act both as pressure lines and return lines, depending on the implement movement.

Edition	Manual	Chapter	Page
2008-10-23	Workshop Manual, Stiga Titan	4 Hydraulic system	20

Implement lifter downwards

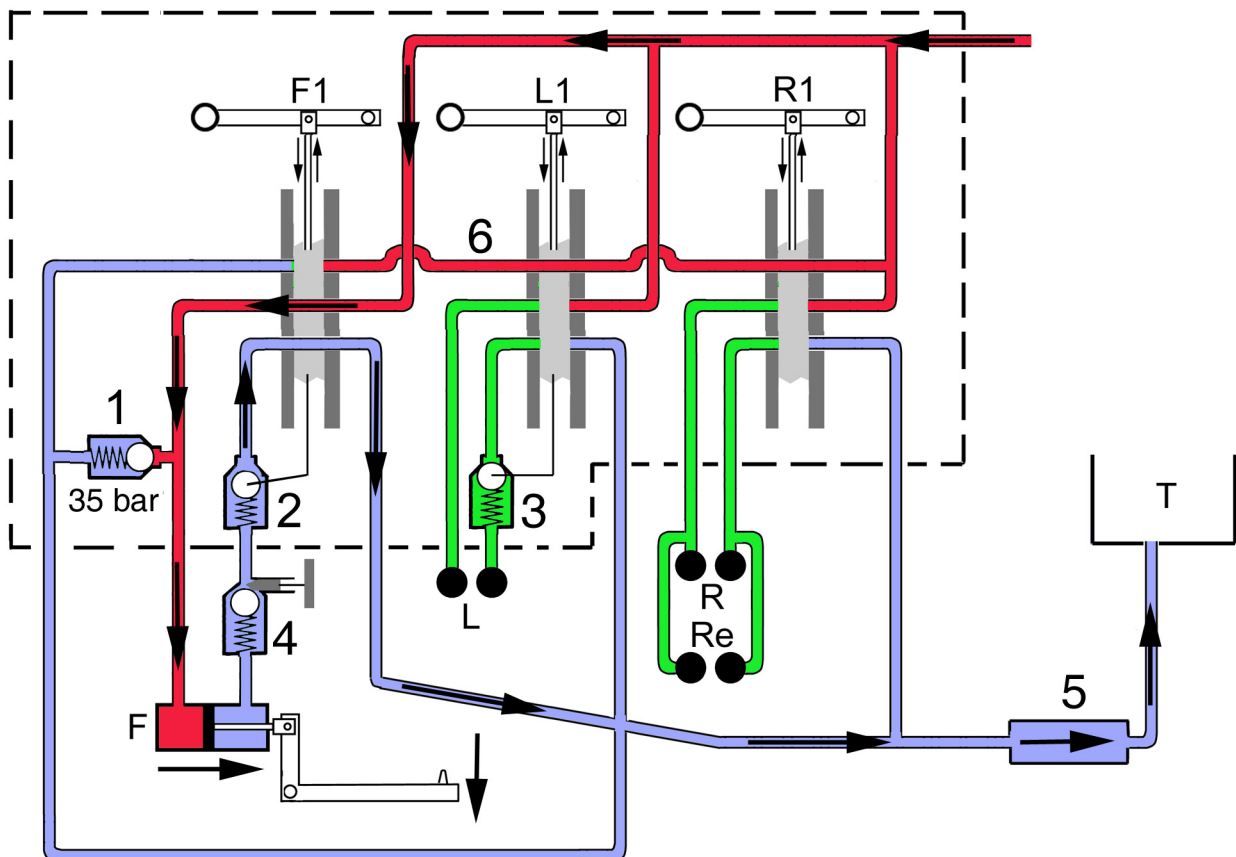

- F. Implement lifter cylinder.
- F1. Control lever for the implement lifter F.
- T. Tank.
- 1. Pressure limiting valve.
- 2. Mechanic actuated non-return valve.
- 4. Check valve lowering.
- 5. Collector block

Colour - Lines

- Red is the feeding pressure lines to the external hydraulics.
- Blue is the return lines with atmospheric pressure.
- Green lines can act both as pressure lines and return lines, depending on the implement.

The by pass line is blocked in valve F1.

Oil flows from the steering unit, through the valve F1. The valve 1 limits the pressure to 30 bar to protect the implement.

The piston in cylinder F is pressed out with limited force and the lifter is lowering.

The oil in the opposite side of the piston is pressed back to the tank via the valves 4, 2 and F1, and the collector block.

The valve 2 is mechanic opened by mechanic connection with the slide in F1 and valve 4 is adjusted to desired lowering speed.movement.

Implement lifter in floating position

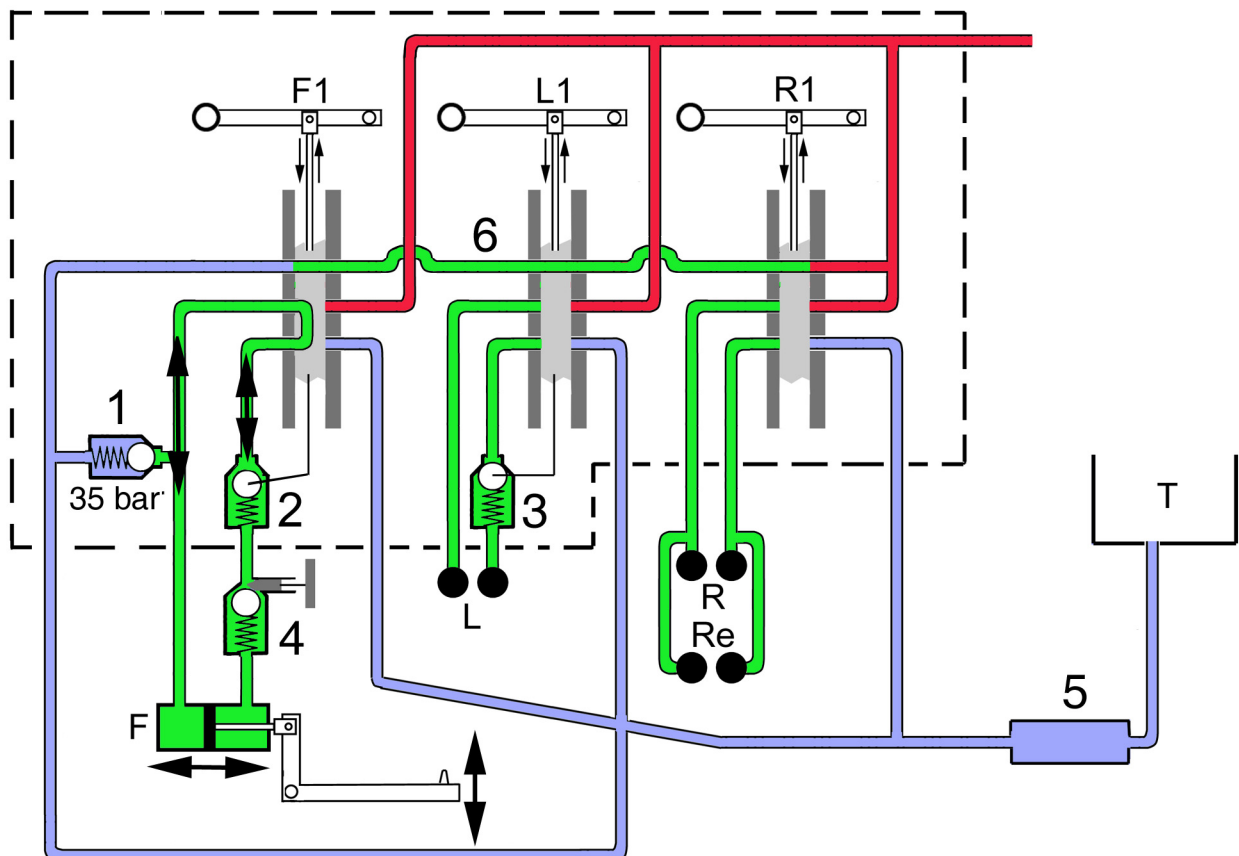

- F. Implement lifter cylinder.
- F1. Control lever for the implement lifter F.
- T. Tank.
- 2. Mechanic actuated non-return valve.
- 4. Check valve lowering.
- 6. By pass line

Colour - Lines

- Red is the feeding pressure lines to the external hydraulics.
- Blue is the return lines with atmospheric pressure.
- Green lines can act both as pressure lines and return lines, depending on the implement movement.

Oil flows from the steering unit, through the by pass line 6. The oil is then flowing back to the tank via the collector block.

The valve 2 become fully open by mechanic connection with the slide in valve F1.

Oil flows freely through the valves 2, 4 and F1, between the piston sides, in the lifting cylinder F.

The valve 2 is mechanic fully opened by mechanic connection with the slide in F1 and valve 4 is also opened (for desired speed at lowering). The limited opening area in valve 4 has no affect to the low oil flow at the floating.

Edition	Manual	Chapter	Page
2008-10-23	Workshop Manual, Stiga Titan	4 Hydraulic system	22

Hydraulic output L, direction A

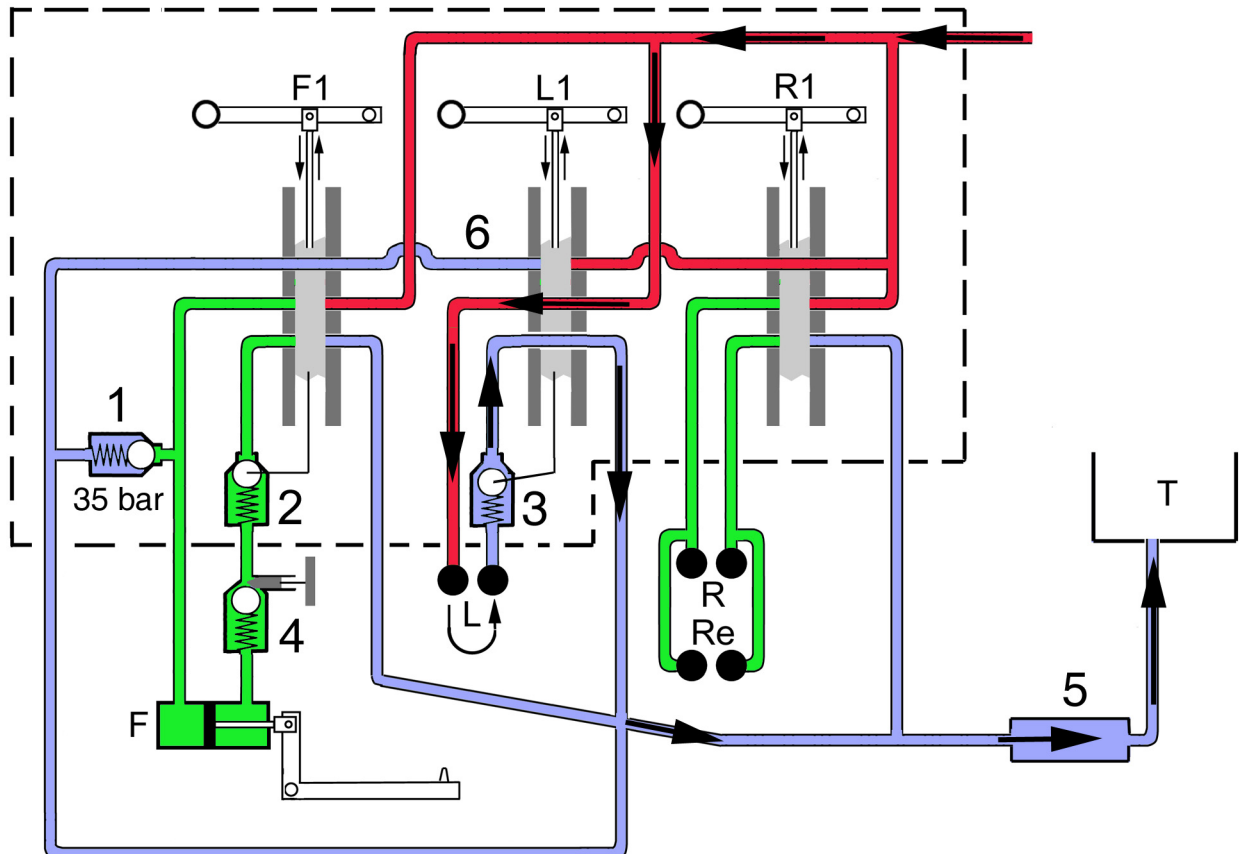

- L. Hydraulic output front, left at B-machines and middle at H-machines.
- L1. Control lever for the hydraulic output L.
- T. Tank

- 3. Mechanic actuated non-return valve.
- 5. Collector block.
- 6. By pass line.

Colour - Lines

- Red is the feeding pressure lines to the external hydraulics.
- Blue is the return lines with atmospheric pressure.
- Green lines can act both as pressure lines and return lines, depending on the implement movement.

The by pass line is blocked in valve L1.

Oil flows from the steering unit, through the valve L1, output L, through the implement performing the movement. Thereafter back to the output, through the valve 3, valve L1, collector block 5 and back to the tank. Valve 3 is mechanical opened by the slide in F1.

Edition	Manual	Chapter	Page
2008-10-23	Workshop Manual, Stiga Titan	4 Hydraulic system	23

Hydraulic output L, direction B

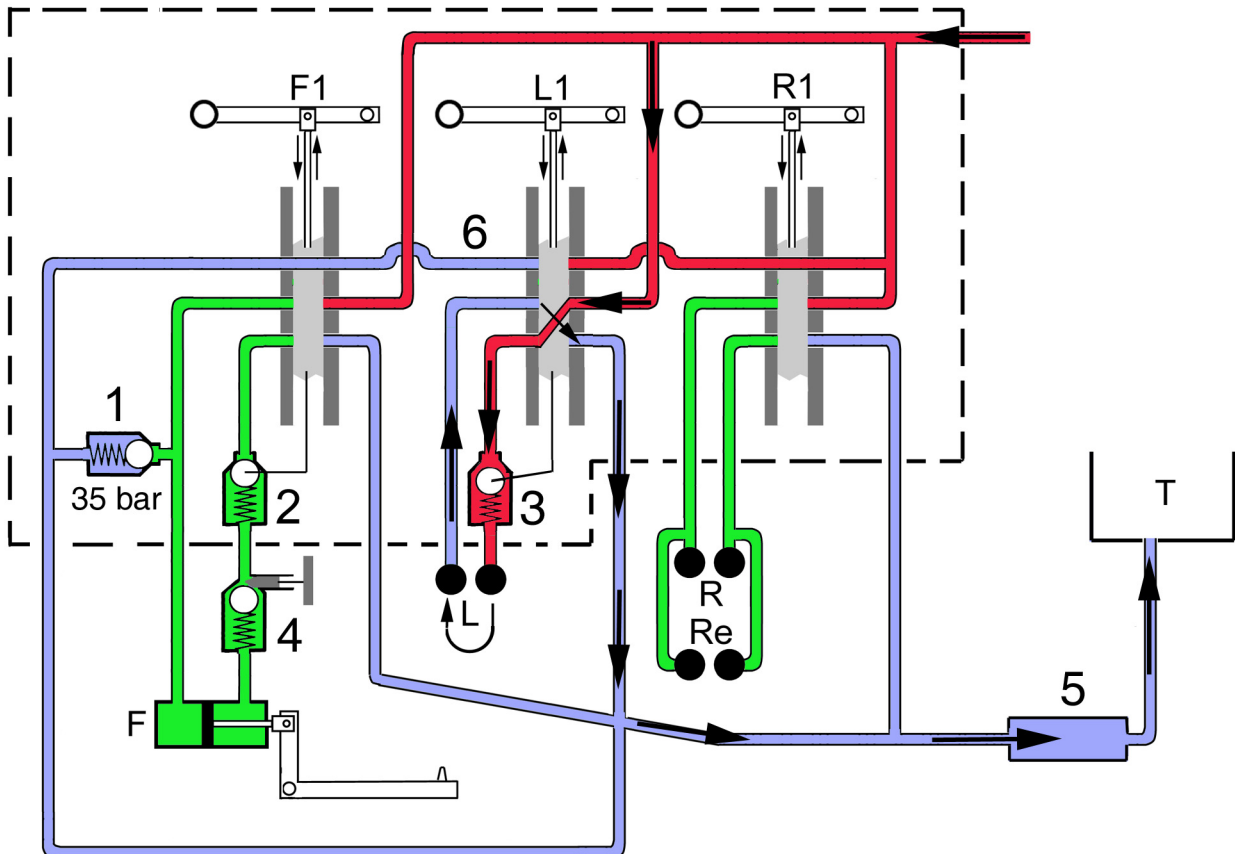

- L. Hydraulic output front, left at B-machines and middle at H-machines.
- L1. Control lever for the hydraulic output L.
- T. Tank

- 3. Mechanic actuated non-return valve.
- 5. Collector block.
- 6. By pass line.

Colour - Lines

- Red is the feeding pressure lines to the external hydraulics.
- Blue is the return lines with atmospheric pressure.
- Green lines can act both as pressure lines and return lines, depending on the implement movement.

The by pass line is blocked in valve L1.
 Oil flows from the steering unit, through the valve L1, valve 3, output L and to the implement performing the movement. Thereafter back to the output, through the valve L1, collector block 5 and back to the tank.
 Valve 3 is opened by the oil pressure.

Edition	Manual	Chapter	Page
2008-10-23	Workshop Manual, Stiga Titan	4 Hydraulic system	24

Hydraulic output R, direction A

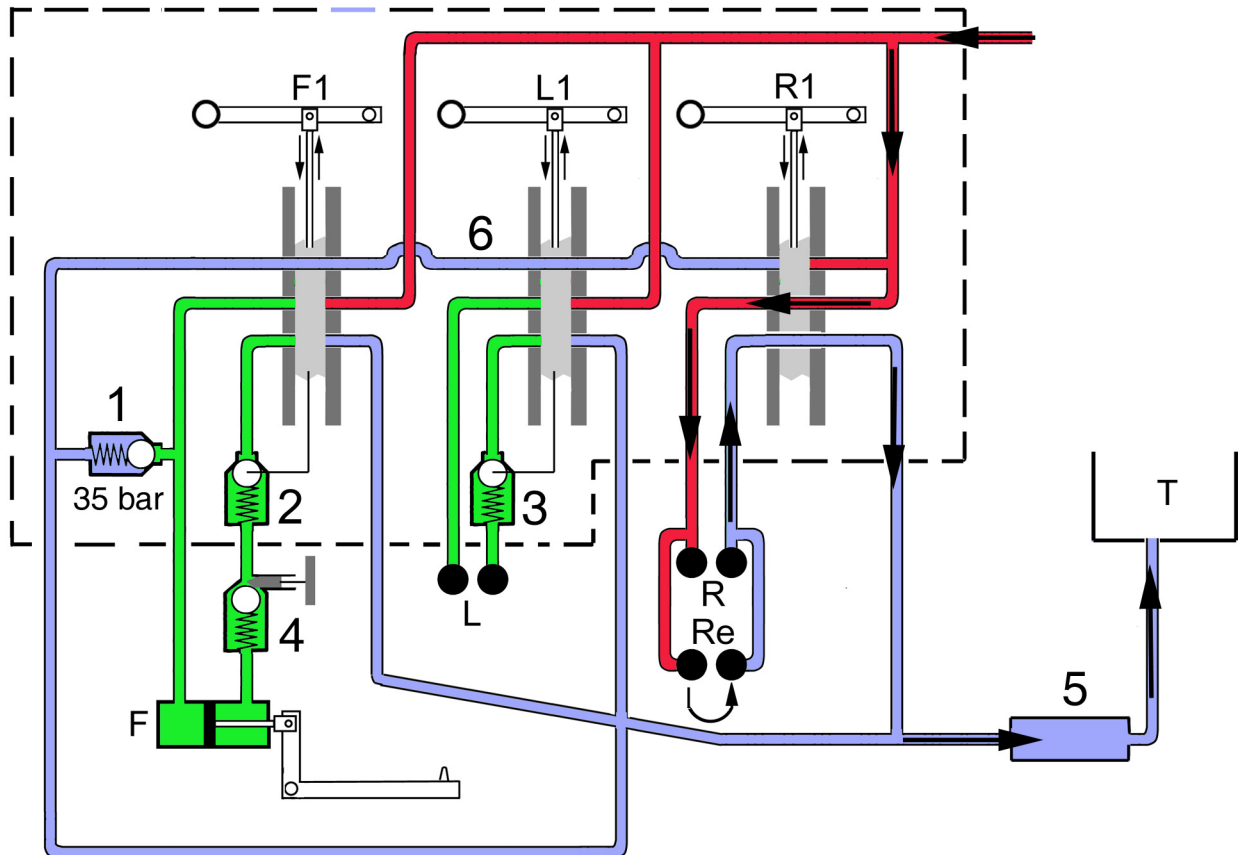

- R. Hydraulic outputs front, right.
- Re. Hydraulic outputs rear.
- R1. Control lever for the hydraulic outputs R and Re.
- T. Tank

- 5. Collector block
- 6. By pass line

Colour - Lines

- Red is the feeding pressure lines to the external hydraulics.
- Blue is the return lines with atmospheric pressure.
- Green lines can act both as pressure lines and return lines, depending on the implement movement.

The by pass line is blocked in valve R1.

Oil flows from the steering unit, through the valve R1, the outputs R/Re and to the implement performing the movement. Thereafter back to the output, through the valve R1, collector block 5 and back to the tank.

The hydraulic outputs R (front) and Re (rear) are connected in parallel. That means that implement cannot be connected to both R and Re at the same time.

Edition	Manual	Chapter	Page
2008-10-23	Workshop Manual, Stiga Titan	4 Hydraulic system	25

Hydraulic output R, direction B

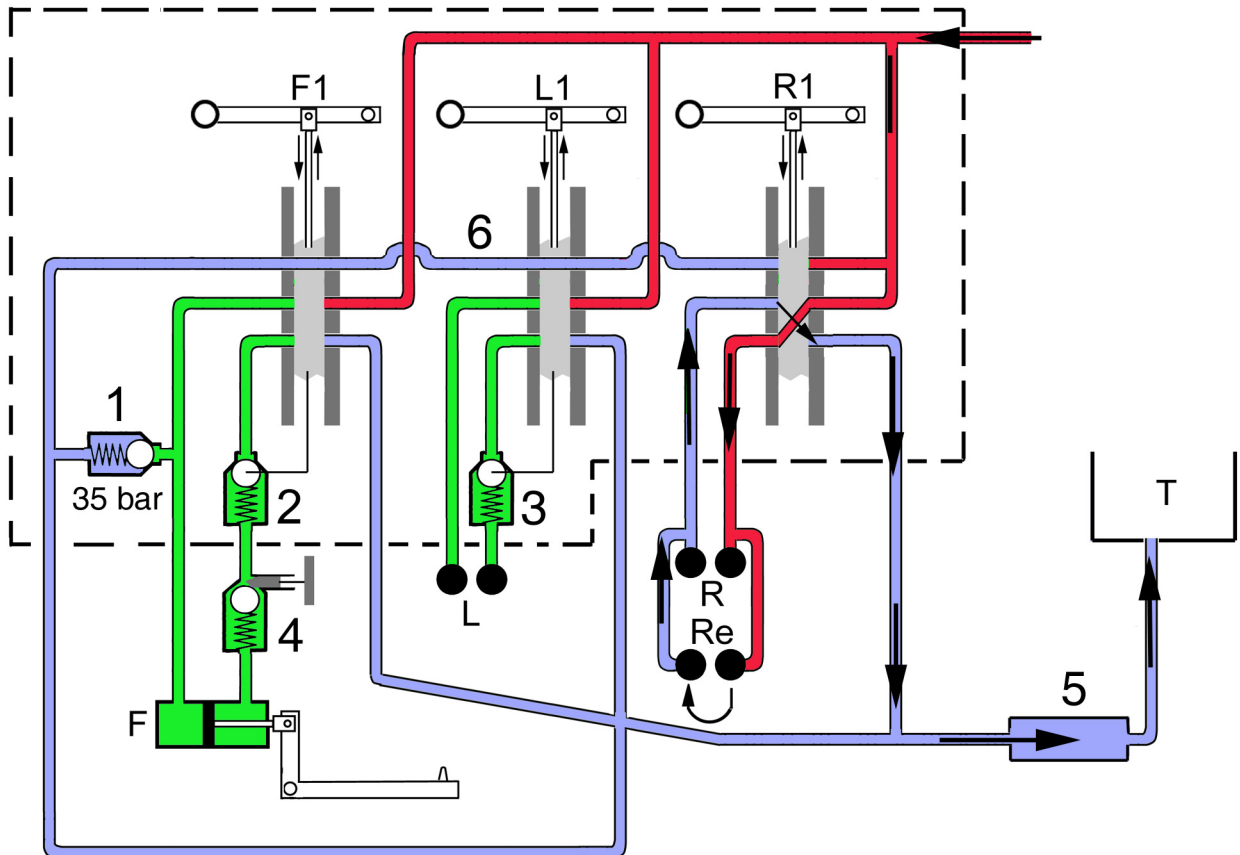

- R. Hydraulic outputs front, right.
- Re. Hydraulic outputs rear.
- R1. Control lever for the hydraulic outputs R and Re.
- T. Tank

- 5. Collector block
- 6. By pass line

Colour - Lines

- Red is the feeding pressure lines to the external hydraulics.
- Blue is the return lines with atmospheric pressure.
- Green lines can act both as pressure lines and return lines, depending on the implement movement.

The by pass line is blocked in valve R1.

Oil flows from the steering unit, through the valve R1, the outputs R/Re and to the implement performing the movement. Thereafter back to the output, through the valve R1, collector block 5 and back to the tank.

The hydraulic outputs R (front) and Re (rear) are connected in parallel. That means that implement cannot be connected to both R and Re at the same time.

Edition	Manual	Chapter	Page
2008-10-23	Workshop Manual, Stiga Titan	4 Hydraulic system	26

4.5 Description of PTO drive

This description is only valid for machines with hydraulic PTO.

4.5.1 Physic description

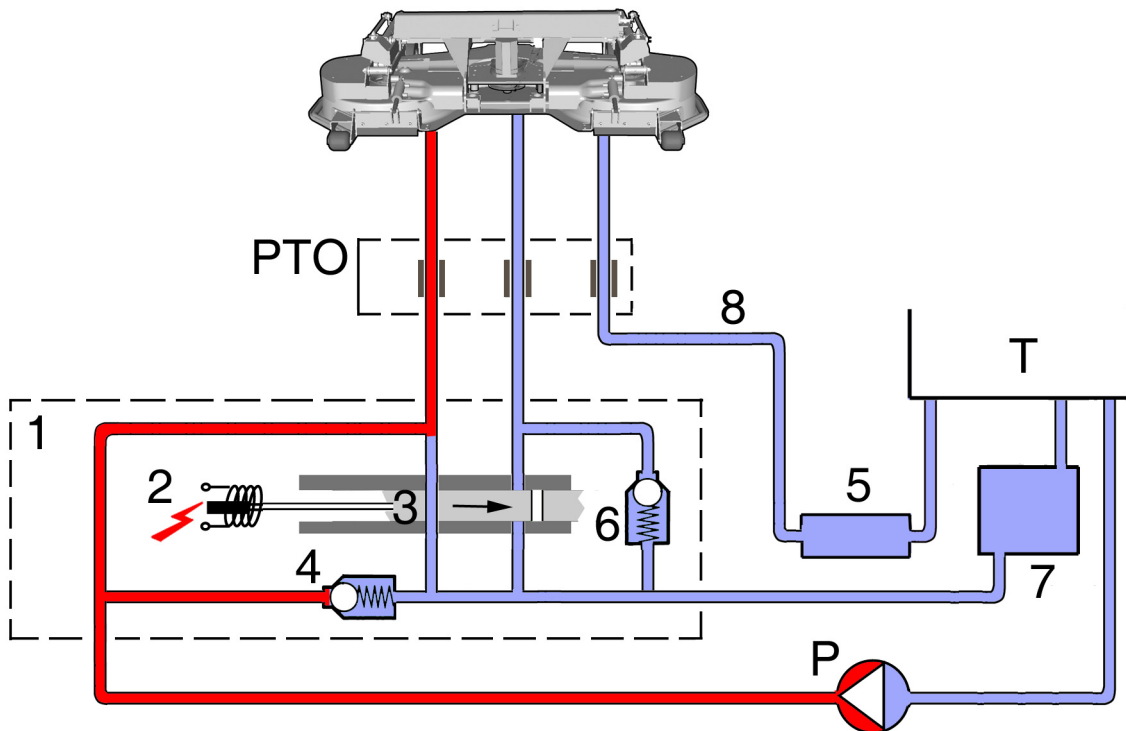

1. PTO valve, including items 2, 3, 4 and 6 below
 2. Electrical solenoid
 3. Slide including a left and a right valve.
 4. Pressure limiting valve, 125 bar.
 5. Collector block
 6. Brake valve
 7. Cooler
 8. Leak oil line
- P. Hydraulic pump
PTO. Hydraulic outputs
PTO1. Switch
T. Tank

Colour - Lines

- Red is the feeding pressure lines to the implement.
- Blue is the return lines with atmospheric pressure.

See also next page regarding locations on the machine and further descriptions of the components.

Edition	Manual	Chapter	Page
2008-10-23	Workshop Manual, Stiga Titan	4 Hydraulic system	27

Location of actuator and hydraulic outputs at the machine

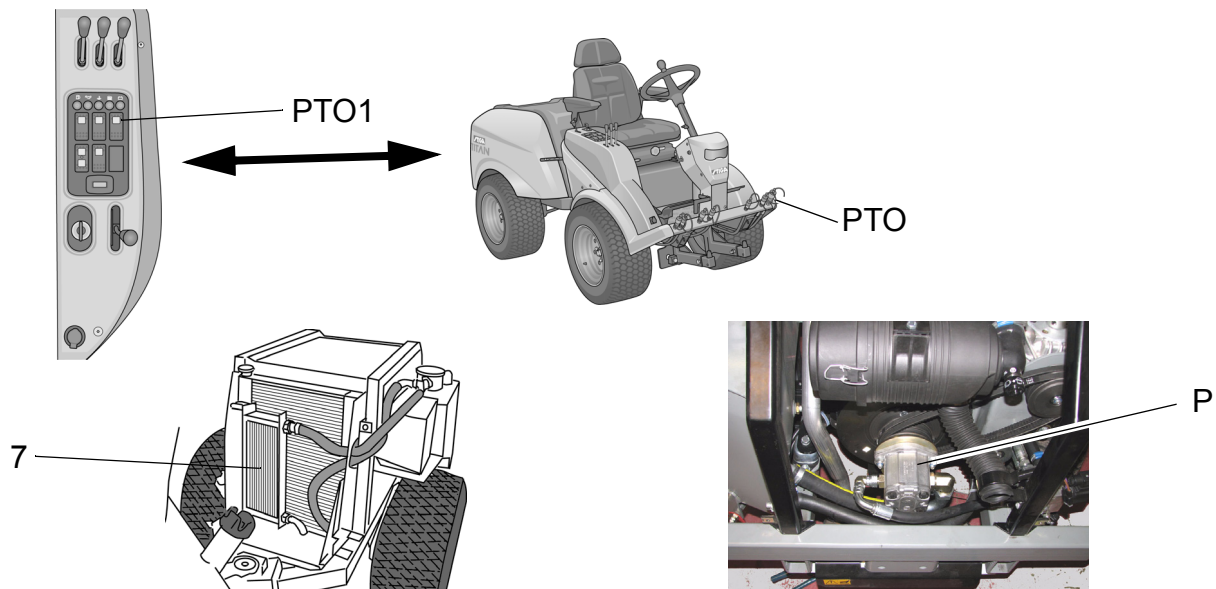

Description of components

1. PTO valve

The PTO valve is an integrated unit, containing all necessary features for the implement driving.

2. Electrical solenoid, 3. Slide

These parts are mechanic connected. The solenoid is affected of the switch PTO1.

4. Pressure limiting valve, 125 bar.

The pressure limiting valve secure that the pressure in the feeding line never can exceed 125 bar, i.e. if the rotating parts are blocked.

6. Brake valve

The brake valve minimizes the stop time for the implement.

7. Cooler

As the motor is started, the PTO oil passes through the cooler. Since the same oil is used for the driving, the cooler keeps the hydraulic oil on a suitable level.

8. Leak oil line

The leak oil line transports all leak oil from the implement hydraulic motor back to the tank via the collector block.

P. Hydraulic pump

The hydraulic pump is direct connected to the motor and runs always when the motor runs.

5. Collector block

The collector block collects leak oil and return oil from all hydraulic components to transit it back to the tank.

Edition	Manual	Chapter	Page
2008-10-23	Workshop Manual, Stiga Titan	4 Hydraulic system	28

4.5.2 Functional description

Not driving the implement

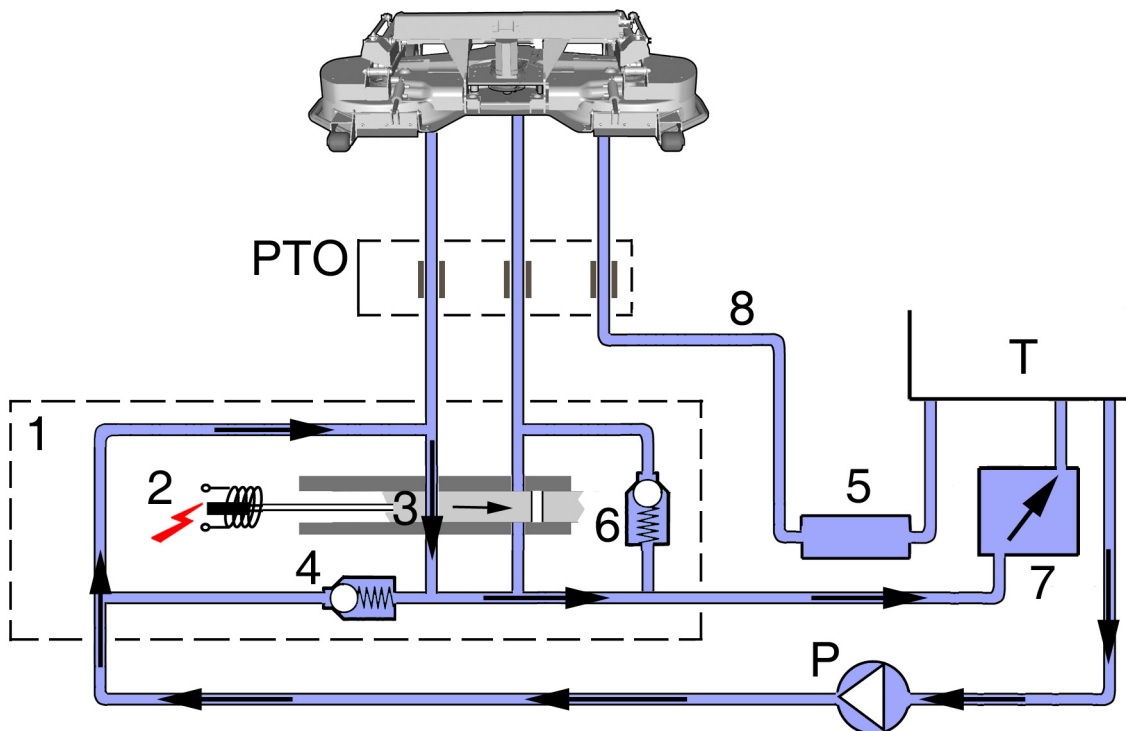

1. PTO valve, including items 2, 3, 4 and 6 below.
 2. Electrical solenoid.
 3. Slide including a left and a right valve.
 4. Pressure limiting valve, 220 bar.
 5. Collector block
 6. Brake valve
 7. Cooler
 8. Leak oil line
- P. Hydraulic pump
PTO.Hydraulic outputs
PTO1.Switch
T. Tank

The solenoid has no voltage and the slide is in its dwell. The left valve is open and the right valve is closed.

The pump pumps oil, which passes the left valve and returns to the tank via the cooler.

Only a slight pressure occurs in the lines, depending on the line and valve resistance.

Colour - Lines

Red is the feeding pressure lines to the implement.

Blue is lines without pressure.

Edition	Manual	Chapter	Page
2008-10-23	Workshop Manual, Stiga Titan	4 Hydraulic system	29

Driving the implement

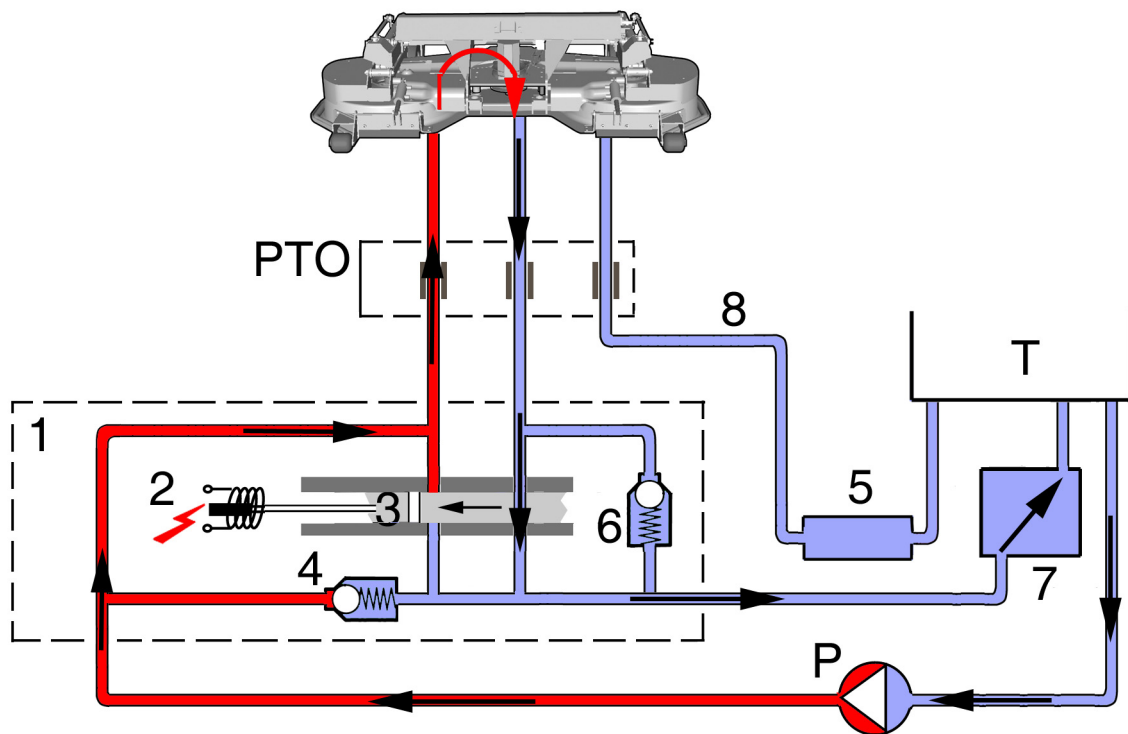

1. PTO valve, including items 2, 3, 4 and 6 below
 2. Electrical solenoid
 3. Slide including a left and a right valve.
 4. Pressure limiting valve, 220 bar.
 5. Collector block
 6. Brake valve
 7. Cooler
 8. Leak oil line
- P. Hydraulic pump
PTO. Hydraulic outputs
PTO1. Switch
T. Tank

Colour - Lines

Red is the feeding pressure lines to the implement.

Blue is lines without pressure.

The solenoid is activated by the switch PTO1 and the slide closes the left valve and opens the right valve.

The pump pumps oil, which is forced through the implement hydraulic motor since the left valve is closed.

From the motor, the oil passes the right valve and returns to the tank via the cooler.

If an abnormal resistance occurs in the pressure line, i.e. blocked motor or similar, the pressure limiting valve 4 will open at 220 bar (adjustable) and the oil returns to the tank via this valve.

Edition	Manual	Chapter	Page
2008-10-23	Workshop Manual, Stiga Titan	4 Hydraulic system	30

Brake function

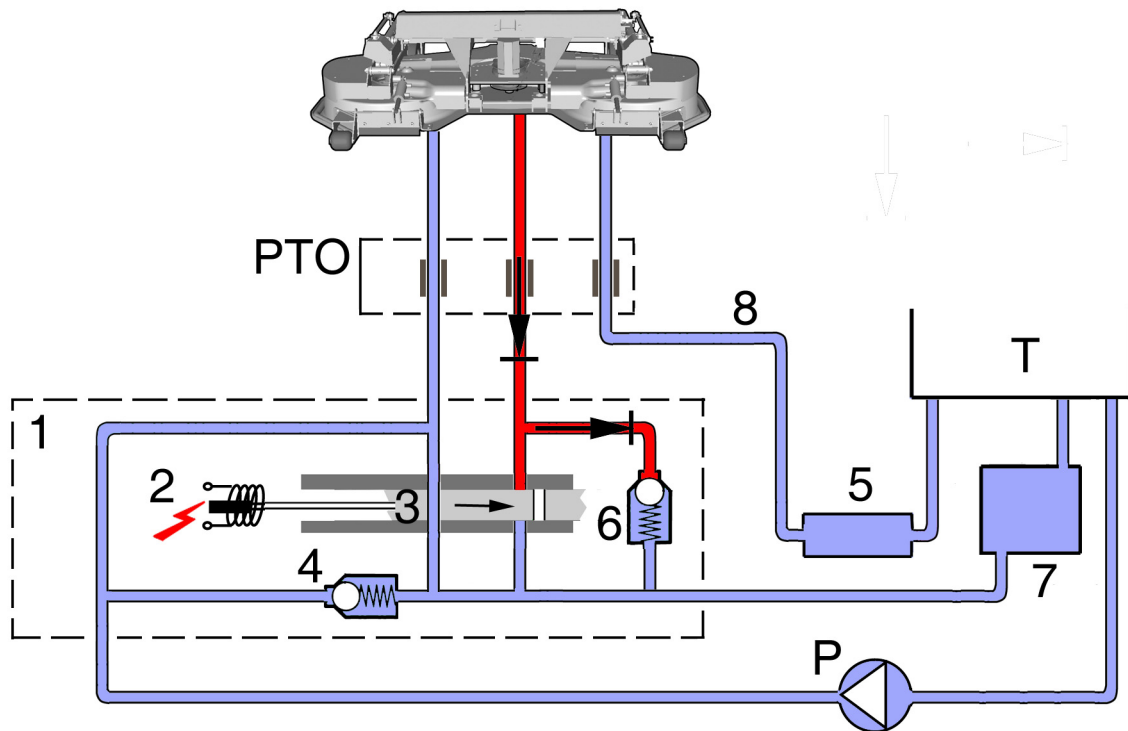

1. PTO valve, including items 2, 3, 4 and 6 below
 2. Electrical solenoid
 3. Slide including a left and a right valve.
 4. Pressure limiting valve, 125 bar.
 5. Collector block
 6. Brake valve
 7. Cooler
 8. Leak oil line
- P. Hydraulic pump
PTO. Hydraulic outputs
PTO1. Switch
T. Tank

Colour - Lines

- █ Red is the feeding pressure lines to the implement.
- █ Blue is lines without pressure.

The switch PTO1 is just turned off and the slide returns to its dwell. The left valve is open and the right valve is closed.

The pressure in the feeding line disappears, but the implement tools will continue rotate due to its kinetic energy and the motor starts to act as a pump.

To get a suitable stopping time, the right valve and the brake valve are working together. The right valve closes and the oil is forced through the brake valve, which ensure a pressure of 10 bar (adjustable).

This will consume the energy from the tools, which will stop smooth and fast.

From the brake valve, the oil returns to the tank via the cooler.

Edition	Manual	Chapter	Page
2008-10-23	Workshop Manual, Stiga Titan	4 Hydraulic system	31

4.6 Trouble shooting



Warning!

Hydraulic oil under pressure can be very dangerous if hoses, lines or other distribution parts are leaking. To avoid personal injuries, always wear protection gloves and protection goggles during works with the hydraulic system.

4.6.1 Drive system

Before the trouble shooting takes place, it is provided that the following states are fulfilled:

- The by-pass valve is in the drive position, outwards. See the figure.
- Oil level in the oil container as desired.
- No air in the hydraulic oil.
- The oil shall not be contaminated, change oil if necessary.

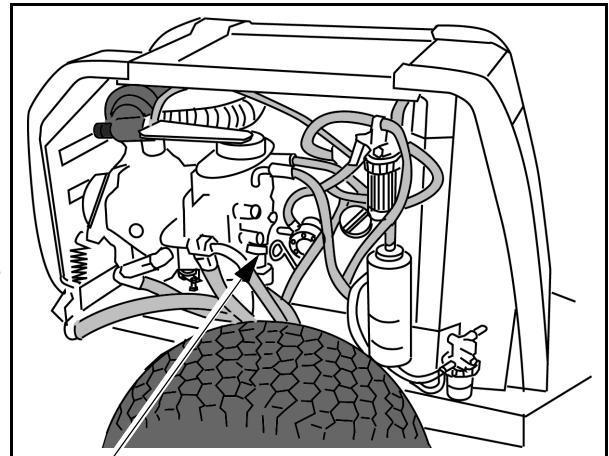

Symptom	Fault	Measure
The machine drives forwards but not backwards.	Big leakage in one of the front motors	Replace the actual motor.
The machine drives backwards but not forwards.	Big leakage in one of the rear motors	Replace the actual motor.
Reduced or no speed.	The belts between motor and pump are slipping. Check if the pump pulley rotates.	Replace the belts.
	Big leakage in the pump.	Replace the pump.
	The charge pump defective.	Replace the pump.
	The pressure limit valve (2,5 bar) for the charge pump defective.	Check the valve and its spring.
	Speed control cable loose or mowed.	Repair/adjust the speed control cable.
Uneven speed.	Air in the system. Oil leakage	Fill up with oil. Check and repair the oil leakage.
Oil overheated.	Oil cooler contaminated. Oil tank filter contaminated.	Clean the actual item.



Edition	Manual	Chapter	Page
2008-10-23	Workshop Manual, Stiga Titan	4 Hydraulic system	32

4.6.2 External hydraulics

Before the trouble shooting takes place, check the following:

- Oil level in the oil container as desired.
- No air in the hydraulic oil.
- The oil shall not be contaminated, change oil if necessary.

Symptom	Fault	Measure
The front mounted implement is not staying in transport position.	Faulty non-return valve 2. Hoses mixed up at the deck. The lifting cylinder is leaking.	See the next two pages.
The set cutting height drops.	Faulty non-return valve 3. Hoses mixed up at the deck. The cutting height cylinder is leaking.	See the next two pages.
Sped control for lowering from transport position works not.	The check valve for lowering is faulty connected.	See page 34.
Implement/function, connected to the hydraulic output L1 is unintended lowering/returning.	Faulty the non-return valve 3.	Replace the non-return valve 3.
	Hoses mixed up at machine or implement.	Connect the hoses correct. Check the function
Oil overheated.	Oil cooler contaminated. Oil tank filter contaminated.	Clean the actual item.
	Leak oil hose not connected to PTO	Connect the hose.
Weak power.	Leak oil hose not connected to PTO	Connect the hose.

Edition	Manual	Chapter	Page
2008-10-23	Workshop Manual, Stiga Titan	4 Hydraulic system	33

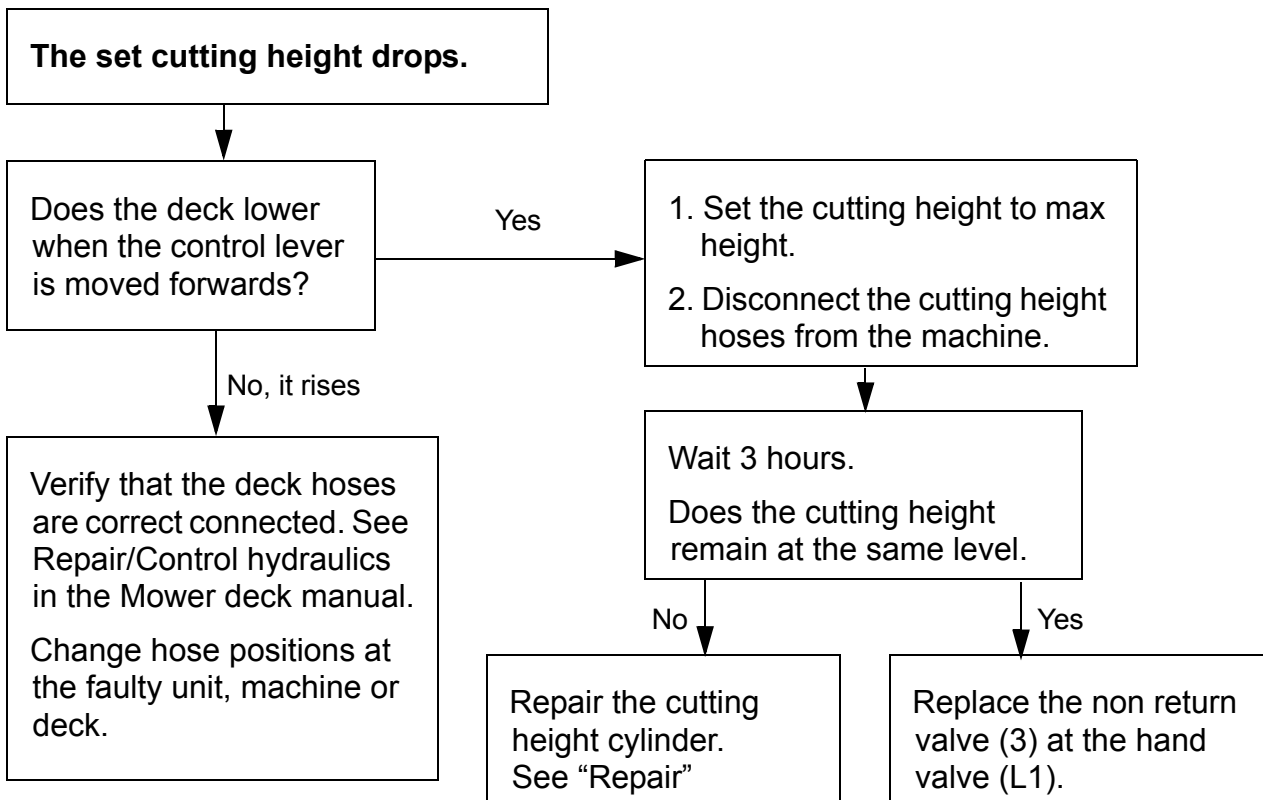
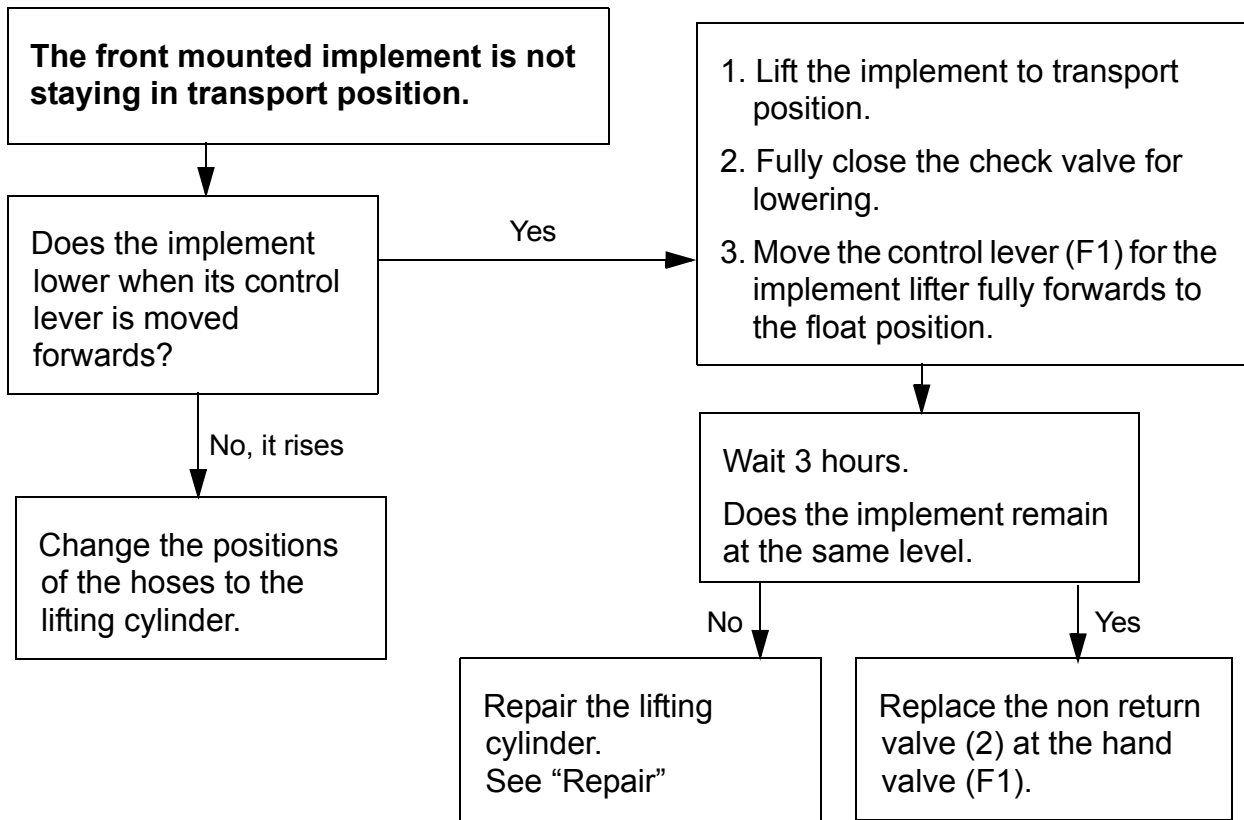

Edition	Manual	Chapter	Page
2008-10-23	Workshop Manual, Stiga Titan	4 Hydraulic system	34

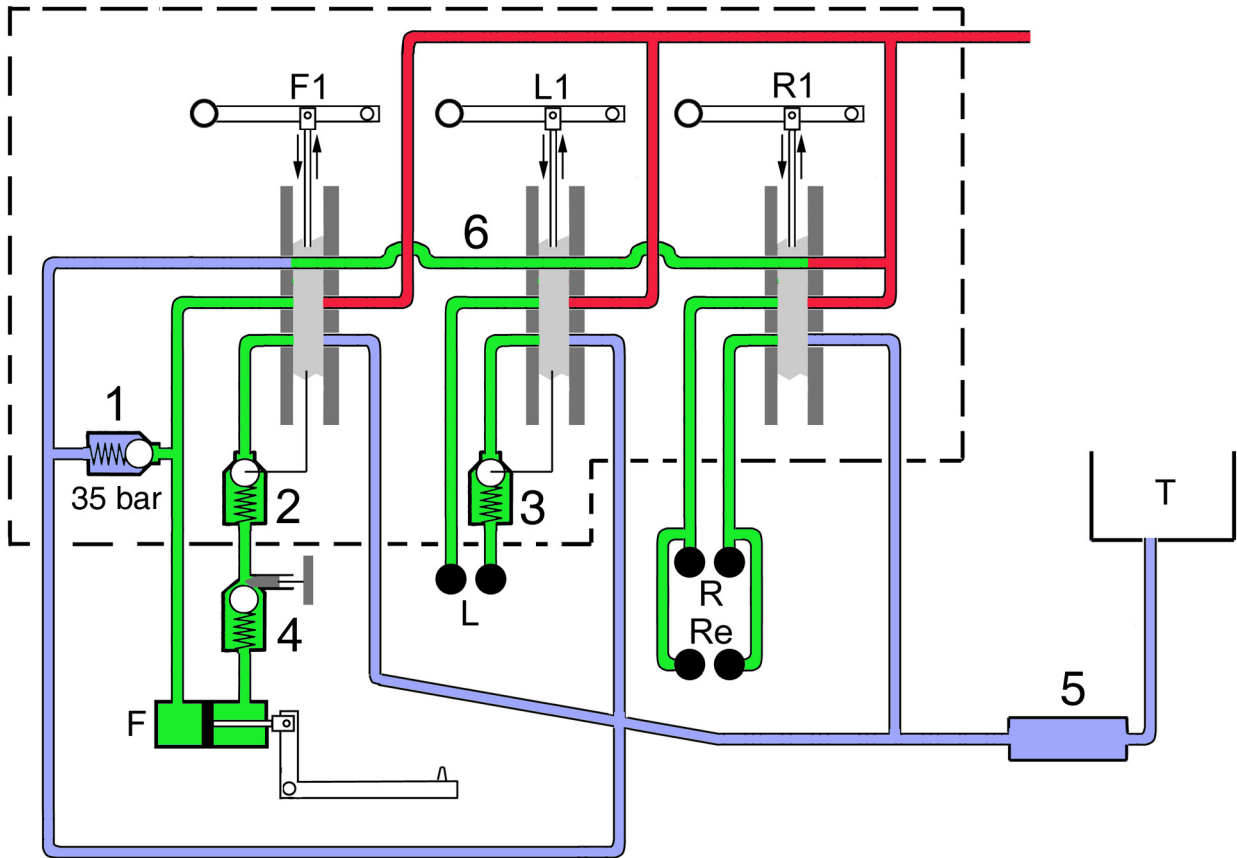

Verifying the check valve (4)

1. Lift the implement to transport position.
2. Close the check valve completely by turning it clockwise.
3. Put the lever (F1) forward to float position and the implementer shall stay in raised position.
4. If the implement drops, perform the solution below.

Solution:

Open the control panel and loosen the check valve. Turn it 180° and fit it again. See the figure. After repair, perform the test above again.

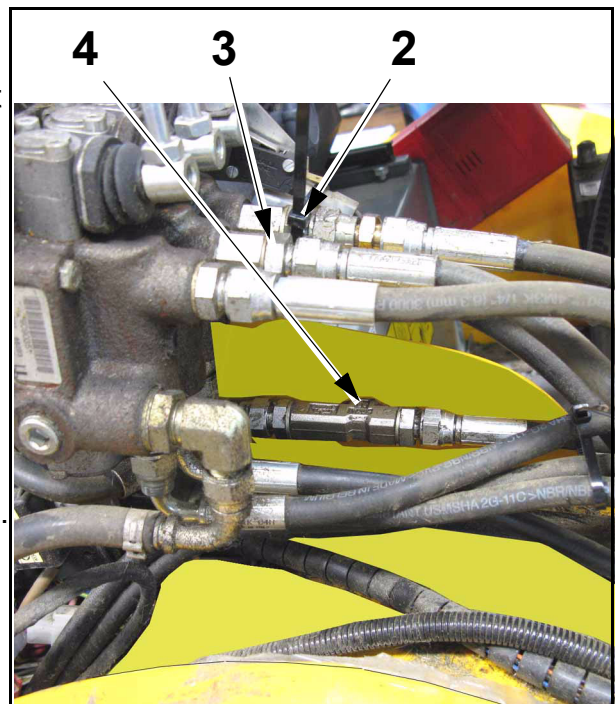

Edition	Manual	Chapter	Page
2008-10-23	Workshop Manual, Stiga Titan	4 Hydraulic system	35

4.7 Repair

4.7.1 Changing hydraulic oil, filter



No contaminants must enter the hydraulic system. This causes serious damage to components of the systems.

Change hydraulic oil and filter as follows:

1. Place the machine on a level surface.
2. Clean the area around the filter (A) thoroughly on the upper part of the hydraulic tank and remove the filter.
3. Place a container under the oil drain plug (C), remove the plug and let the oil run out into a container. The container must have a capacity of 20 litres.
4. Dispose of the oil according to local regulations.
5. Install the oil drain plug. Tighten to 40 Nm.
6. Fill with new oil through the filter opening at the top.
Oil: See Section 1.
Oil quantity when changing: See Section 1.
7. Reinstall the filter with the following components:
 - D Cover
 - G Gasket. Check that the washer is intact.
 - F New filter. The filter must always be replaced when changing the oil.
 - E Spring
8. After filling the oil, start the engine and run the machine for a few minutes and check for oil leakage.
9. Check the oil level. See below.

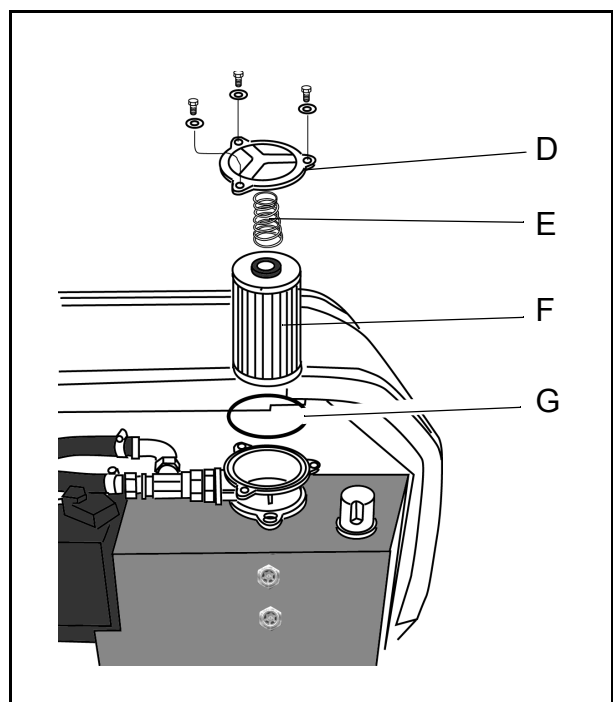
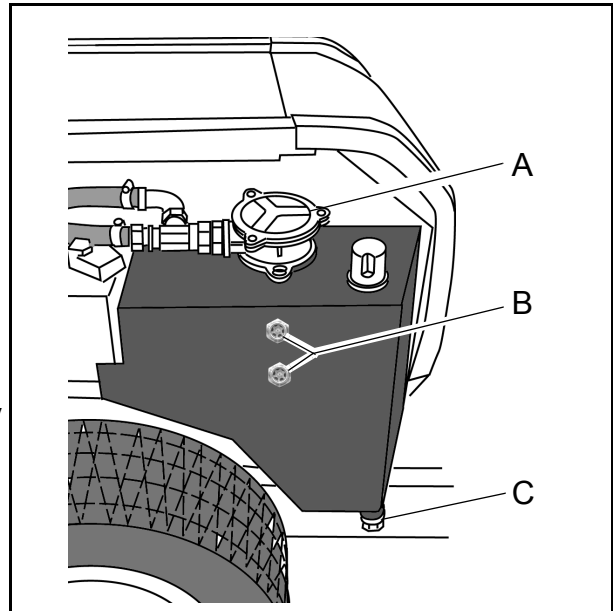

Edition	Manual	Chapter	Page
2008-10-23	Workshop Manual, Stiga Titan	4 Hydraulic system	36

4.7.2 Hydraulic oil level indicator

There must be oil inside the lower sight glass (B).

There must not be any oil inside the upper sight glass.

If the oil level is too high there is a risk of oil flowing out through the bleed valve. If the oil level is too low there is a risk of an increase in the oil temperature and damage to the hydraulic system.

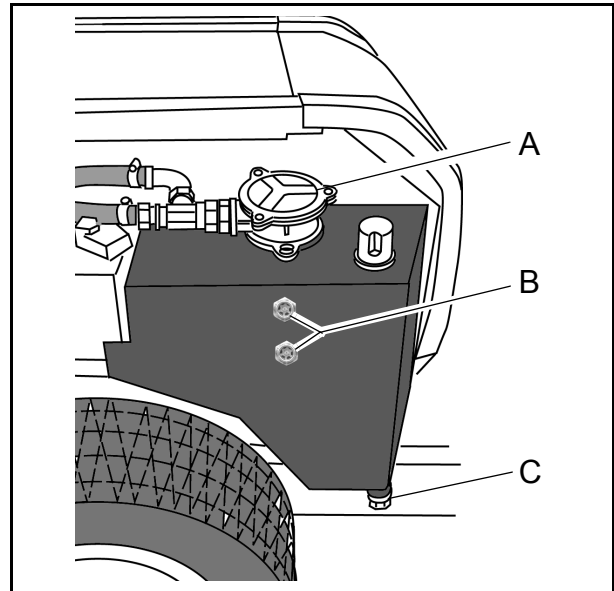

4.7.3 Disassembly the hydraulic pumps

Disassembly the hydraulic pumps as follows:

1. Drain the hydraulic oil. See above.
2. Dismantle the cruise control device, fitted to the hydraulic pumps. See section 2.
3. Remove the hydraulic pump belts. See section 5.
4. Remove the pump pulley by holding it with a big polygrip or similar while loosening the axle nut. Use a 19 mm spanner.
5. Loosen the brake bracket by unscrewing the two nuts.
6. Bend the bracket together with the throttle wire away from the working area. If necessary, lock it in place with a lacing wire or similar.

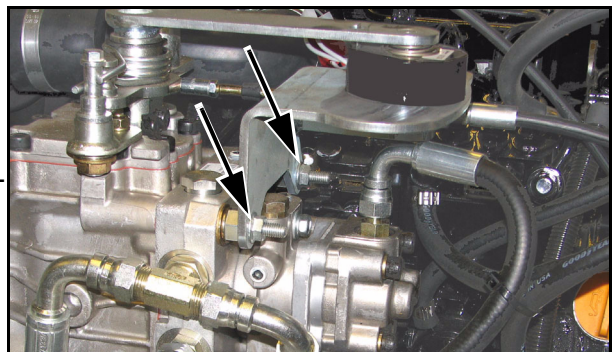
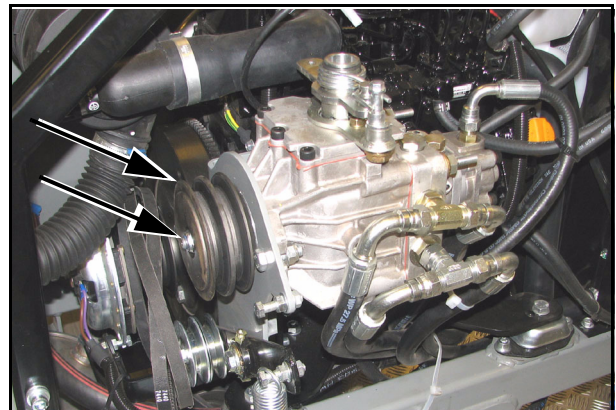

Edition	Manual	Chapter	Page
2008-10-23	Workshop Manual, Stiga Titan	4 Hydraulic system	37

7. Loosen and disconnect the following hydraulic hoses. Before the loosening shall the hoses A-D be marked up. Use an inkpen or similar. Use preferably the letters used here.

- A Drive hose, front motor
- B Drive hose, rear motor
- C Drive hose, rear motor
- D Drive hose, front motor
- E External hydraulik tank hose
- F External hydraulic hose

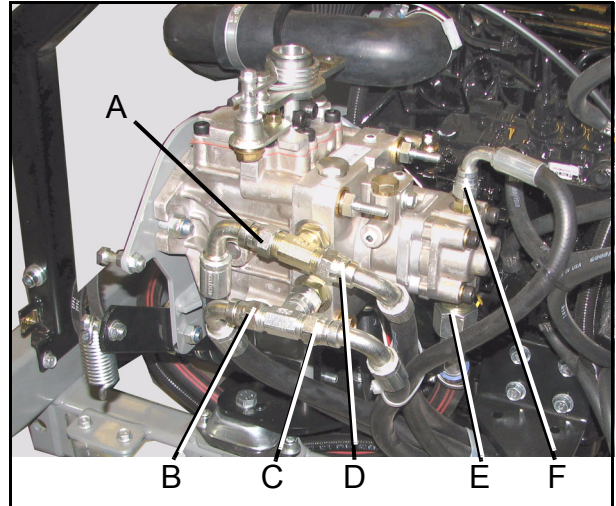

8. Loosen and remove the two pump attachment screws and move the pump carefully outwards. The leak oil hose is still connected to the pump inside.

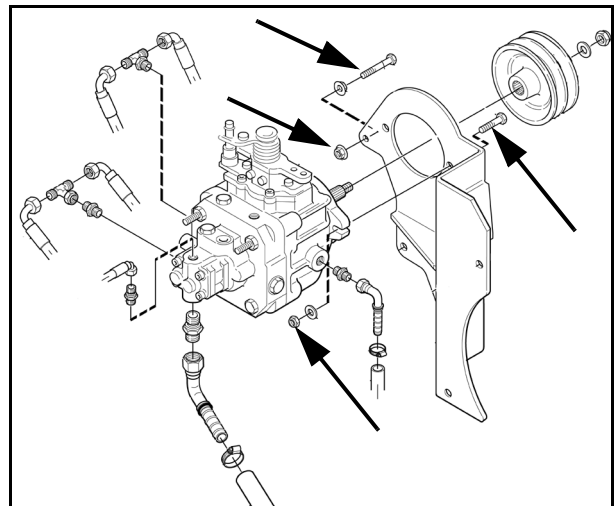

9. Loosen and disconnect the leak oil hose and take out the pump.

10. Disassemble all connections from the pump and install them in the respective places at the new pump.

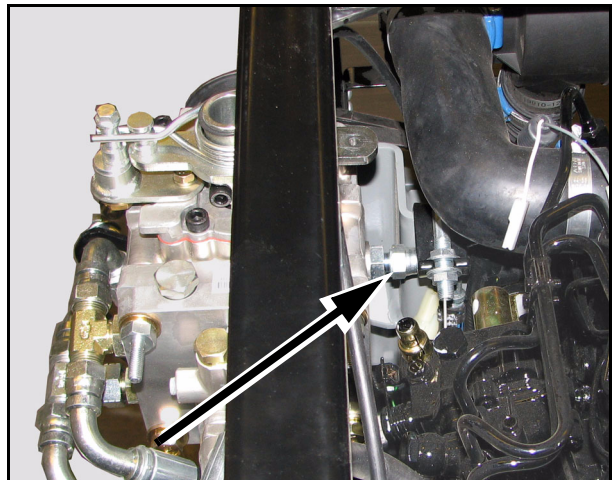

Edition	Manual	Chapter	Page
2008-10-23	Workshop Manual, Stiga Titan	4 Hydraulic system	38

4.7.4 Disassembly the PTO pump

Disassembly the PTO pump as follows:

1. Drain the hydraulic oil. See above.
2. Disconnet the hydraulic hoses from the pump.
3. Dismantle the pump together with its carrier plate/pulley. See "5.4 Hydraulic pumps belts, 26H, 26HS" in section 5.

Note the stabilisation spring. It shall also be unhooked.

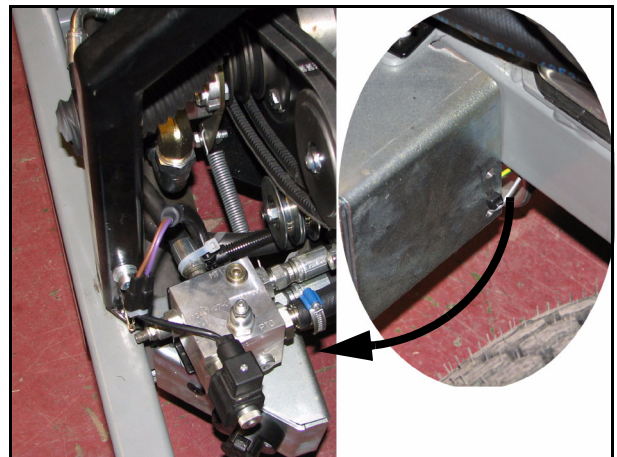
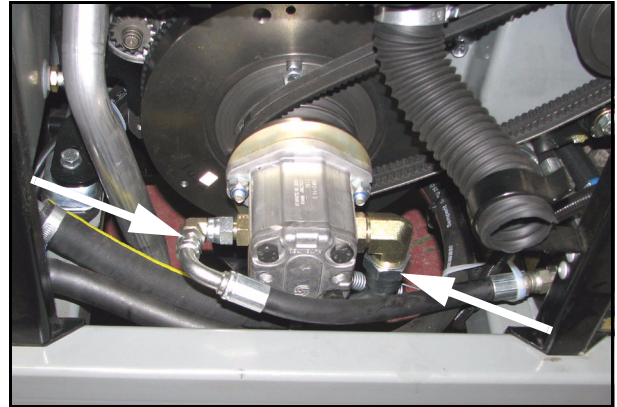

4. Take out the pump from the machine and set up the pulley in a vise.
5. Unscrew the pulley nut and remove the pulley from the shaft. If neccessary, use a puller. The shaft fitting is conical.

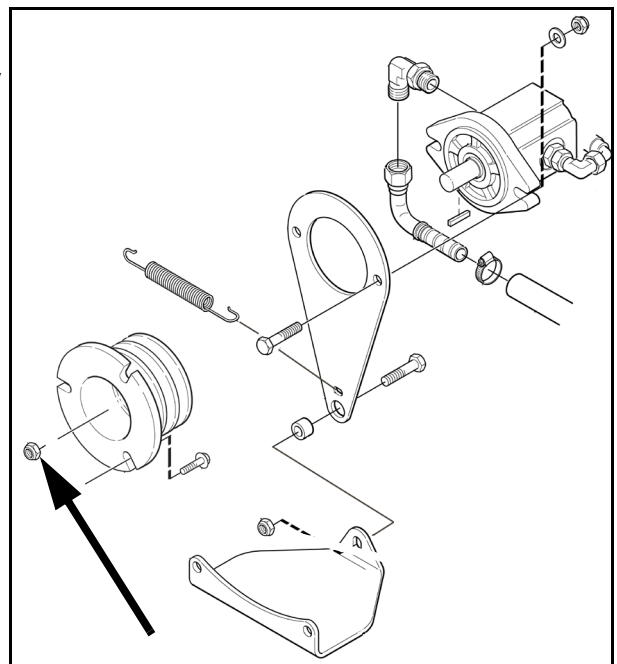

Edition	Manual	Chapter	Page
2008-10-23	Workshop Manual, Stiga Titan	4 Hydraulic system	39

4.7.5 Changing of O-rings in the steering servo

Disassembly

1. Disassemble the steering servo from the machine. See section 3.
2. Clean thoroughly the steering servo.
3. Prepare a clean surface on the working bench and cover with a clean paper or similar.



No contaminants must enter the hydraulic system. This causes serious damage to components of the systems.

4. Set up the steering servo in a vise. The unit must be set entirely vertical. See the note below.
5. Disassemble the 5 connections (A).
6. Lift carefully up the following parts and place them on the clean surface:
 - C. Connection plate
 - D. Distance shaft
 - E. Impeller
 - F. Impeller shaft
 - H. Pump body
 - J. Flow disc

Note! Be sure to keep the body entirely vertical when removing the valve shaft (K). If not, the locking pin (L) can move and lock the unit inside the body.

K. Valve shaft. Do not remove the locking pin (L). Secure it with tape or similar after removal.

M. Damper rod.

N. Axial bearing (roller cage and two support washers).

7. If the O-ring at the pressure limiting valve (Q) shall be replaced, also disassemble the valve.

Note! If the pressure limiting valve has been touched, the pressure must be readjusted to 125 bar.

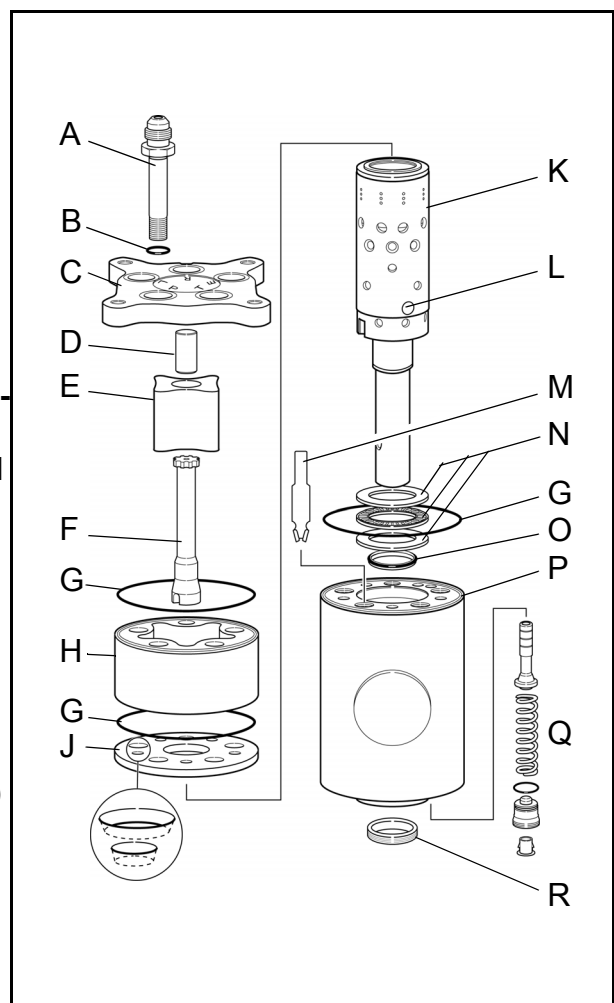
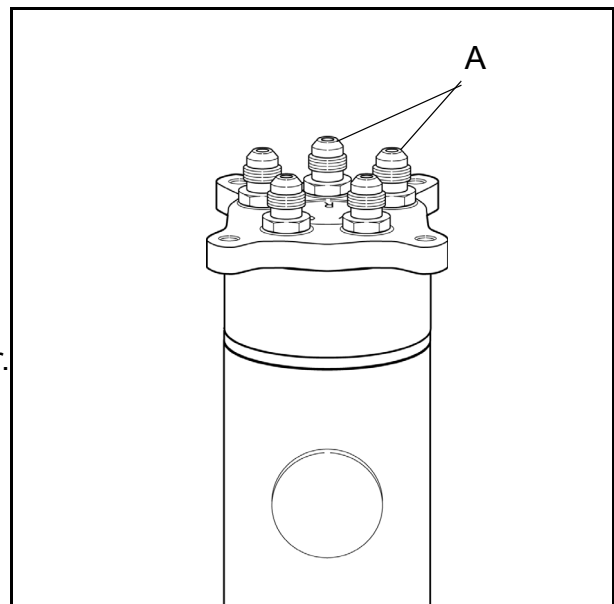

Edition	Manual	Chapter	Page
2008-10-23	Workshop Manual, Stiga Titan	4 Hydraulic system	40

Changing of sealing rings

1. Remove the body from the vise.
2. Note the fittings of the two sealing rings (O and R) and remove them with a screwdriver or similar.
3. Fit the new sealing rings in the same direction as noted above. Use a sleeve with the same diameter as the sealing rings.
4. If necessary, replace the O-ring at the pressure limiting valve (Q).

Assembly of the steering servo

1. Set up the steering servo in a vise. The unit must be set entirely vertical. See below.



No contaminants must enter the hydraulic system. This causes serious damage to components of the systems.

2. Assemble all parts in the reverse order. Replace all O-rings (3xG, 5xB) with new one during the assembly. Remark the following important advises during the assembly:
 - Apply some motor oil on the sealing ring surfaces.
 - Check that the locking pin in the valve shaft not protrude during the insertion. If not, there is a risk of locking in the body grooves.
 - The damper rod shall be fitted in hole (P). See the relation to the oval at the body.
 - The flow disc (J) shall be turned with the bigger diameter of the holes upwards.
 - The connection plate shall be turned with connection (P) in hole (P). See the relation to the oval at the body.
3. If the O-ring at the pressure limiting valve (B) is replaced, the pressure must be readjusted to 125 bar.
4. Assemble the steering servo to the machine. See section 3.

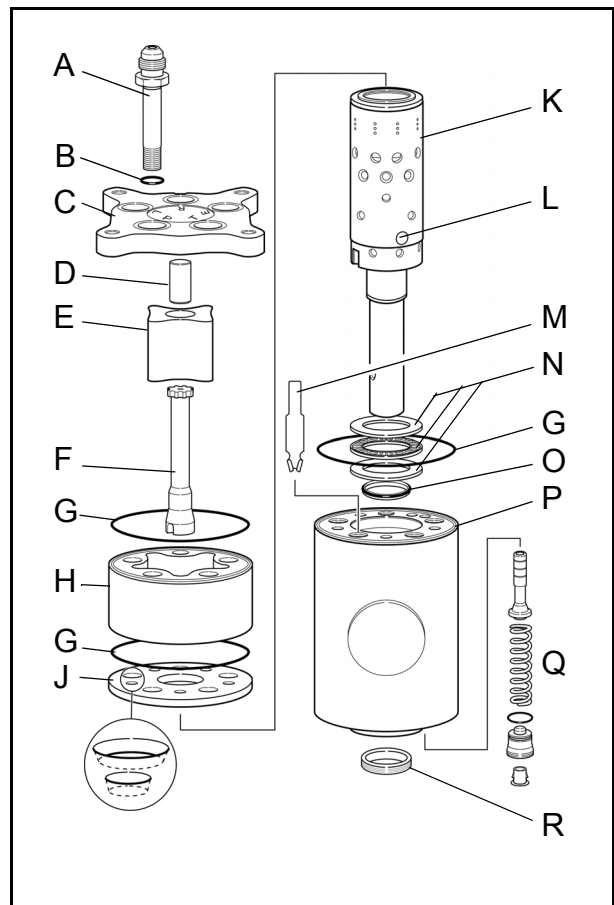
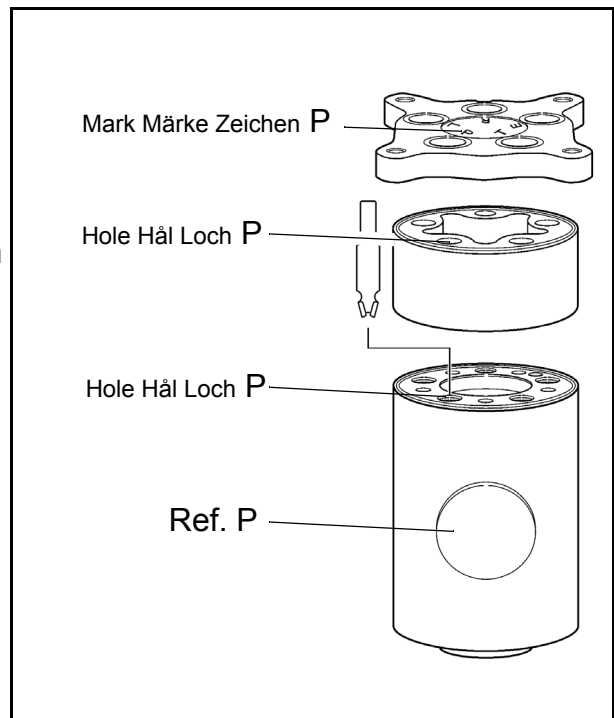

Edition	Manual	Chapter	Page
2008-10-23	Workshop Manual, Stiga Titan	4 Hydraulic system	41

4.7.6 Changing of O-rings in hydraulic cylinders

Note! This information is valid for the steering cylinder and for the lifting cylinder.

Disassembly

1. Disassemble the actual hydraulic cylinder from the machine. See section 3.
2. Clean thoroughly the steering servo.

3. Prepare a clean surface on the working bench and cover with a clean paper or similar.



No contaminants must enter the hydraulic system. This causes serious damage to components of the systems.

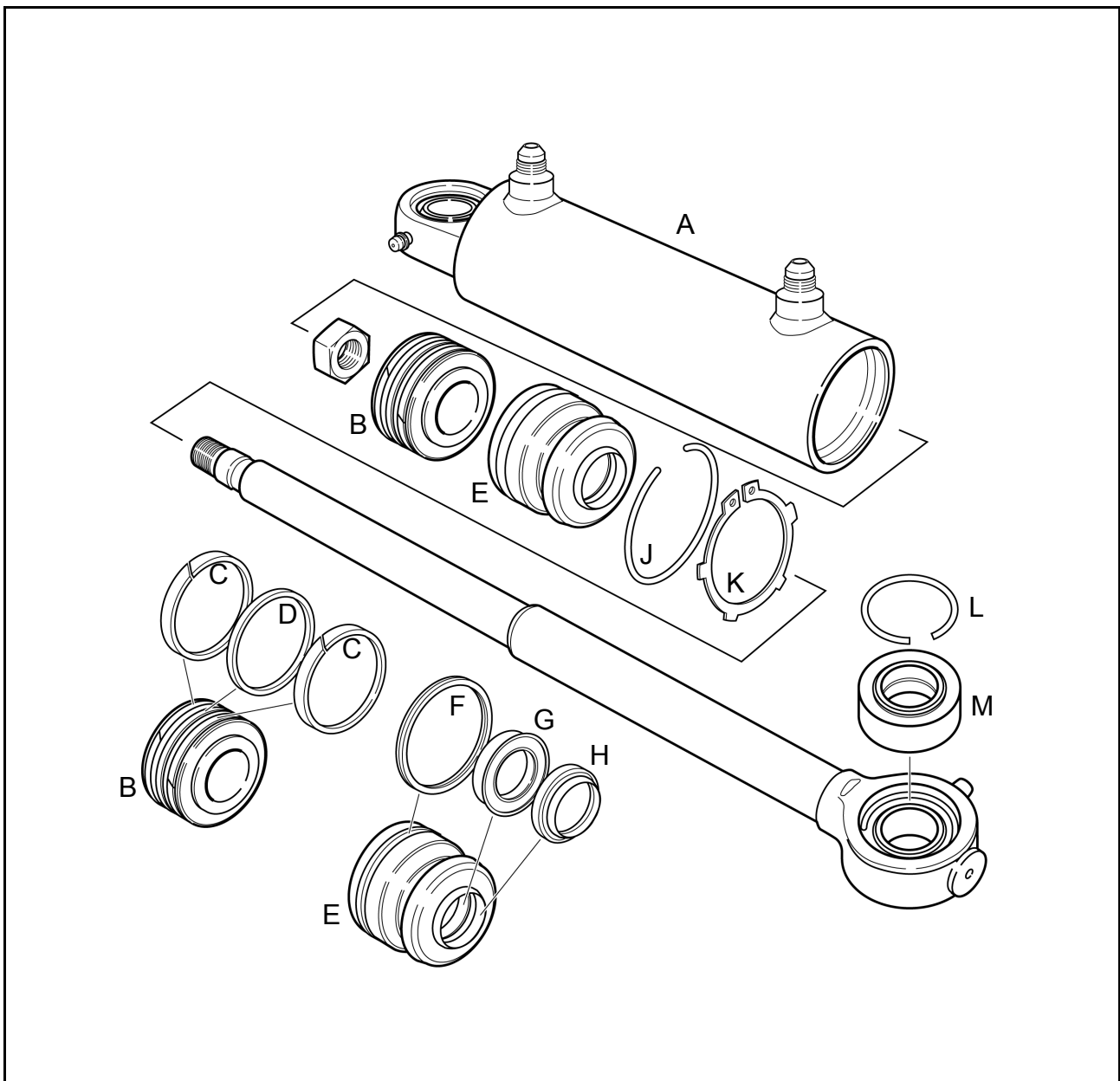

Edition	Manual	Chapter	Page
2008-10-23	Workshop Manual, Stiga Titan	4 Hydraulic system	42

4. For an easier and safer work, place the cylinder in a vise.
5. Remove the locking ring (K) and let it remain over the piston rod.
6. Push the sealing plug (E) inwards ca 10 mm and pull out the locking ring (J).
7. Pull out the entire piston with sealing plug.

Changing of sealing rings

1. Remove the sealing rings to be replaced.
2. Fit carefully the new sealing rings in the actual places.

Replacing the link bearing (M)

If the link bearings shall be replaced, take out the locking ring (L) and press out the bearing.

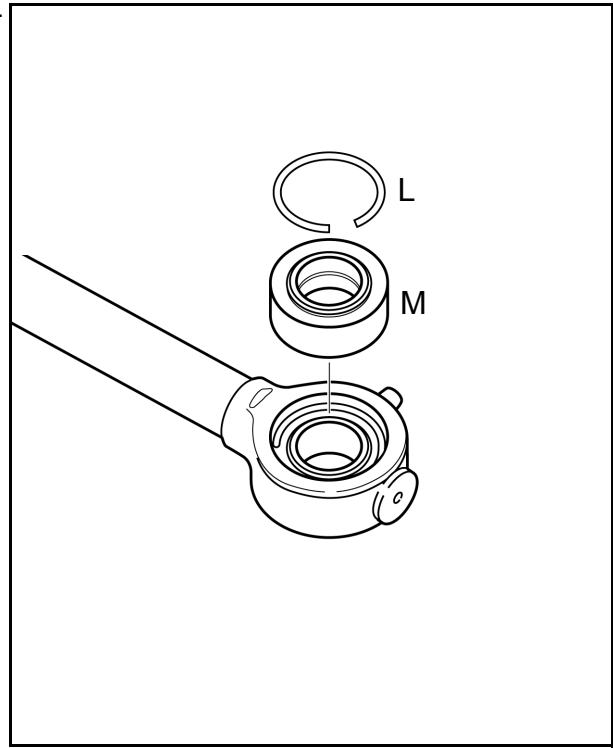

Assembly of the hydraulic cylinder

1. Set preferably up the hydraulic cylinder in a vise.



No contaminants must enter the hydraulic system. This causes serious damage to components of the systems.

2. Assemble all parts in the reverse order.
Remark the following important advises during the assembly:
 - Apply some motor oil on the sealing ring surfaces.
 - Be carefully when inserting rods, cylinder walls etc. against the sealing ring not to damage them.
3. Assemble the cylinder to the machine. See section 3.

Edition	Manual	Chapter	Page
2008-10-23	Workshop Manual, Stiga Titan	4 Hydraulic system	43

4.8 Adjustments

4.8.1 Pressures, PTO drive, 26H, 26HS

The PTO drive has two adjustable pressures:

- Max pressure, adjusted to 125 bar at factory.
- Brake pressure, adjusted to 10 bar at factory.

Items at the PTO valve:

1. MT1, measure terminal for the max pressure.
2. Adjustment of brake pressure.
3. Adjustment of max pressure
4. MP, measure terminal for the brake pressure.

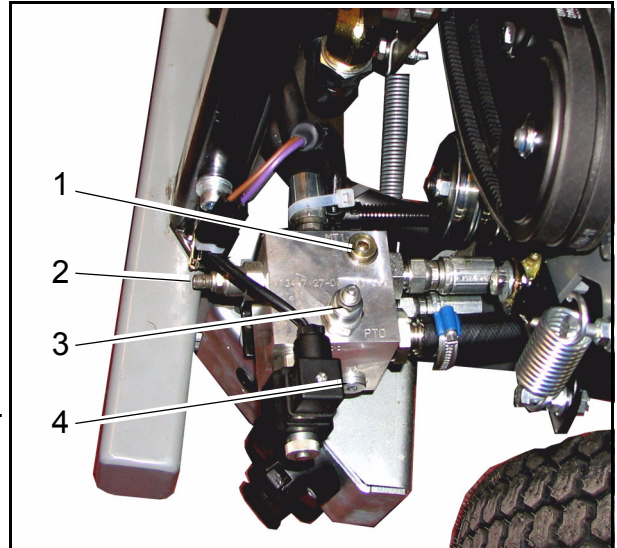

Adjustment of max pressure

1. Connect a manometer to measure terminal MT1.
2. Start the motor and activate the PTO without any implement connected.
3. Adjust the pressure with valve 3 and read the pressure at the manometer.

Adjustment of brake pressure

1. Connect a manometer to measure terminal MP.
2. Start the motor and activate the PTO with an implement connected.
3. Switch off the implement and read the brake pressure at the manometer.
4. Adjust valve 2 and repeat the reading until desired brake pressure and stop time is obtained.



Edition	Manual	Chapter	Page
2008-10-17	Workshop Manual, Stiga Titan	5 Mechanical power transmissions	1

5 Mechanical power transmissions

Contents in this chapter

5.1 Belt theory.....	2	5.4 Hydraulic pumps belts,	
5.1.1 Why it is so important to use original belts from the retail dealer?	2	26H, 26HS	8
5.2 PTO belt, 20B, 26B	4	5.4.1 Description	8
5.2.1 Description	4	5.4.2 Disassembly	8
5.2.2 Disassembly	4	5.4.3 Inspections	10
5.2.3 Inspections	5	5.4.4 Assembly	10
5.2.4 Assembly	6	5.5 PTO pulley with bearing,	
5.3 Hydraulic pumps belts,		20B, 26B	11
20B, 26B	6	5.5.1 Description	11
5.3.1 Description	6	5.5.2 Disassembly	11
5.3.2 Disassembly	7	5.5.3 Assembly	12
5.3.3 Inspections	7		
5.3.4 Assembly	7		

General

The mechanical power transmission consists of all parts involved to transmit the motor power to the respective consumer item. These are as follows:

- The hydraulic pumps drive at all machines.
- The articulation point pulley at machines with belt driven PTO.

This chapter describes the mechanical power transmissions. It also describes the replacement procedures of belts, clutch and bearings. There are no adjustment procedures involved in this system. All adjustments are performed automatic with spring loaded tension arms.

Edition	Manual	Chapter	Page
2008-10-17	Workshop Manual, Stiga Titan	5 Mechanical power transmissions	2

5.1 Belt theory



5.1.1 Why it is so important to use original belts from the retail dealer?

The table below shows the demands on normal commercial grade belts compared to demands on original spare parts belts from the retail dealer. The later are designed and manufactured in close connection between the subcontractor and the rider manufacturer.

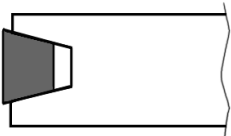
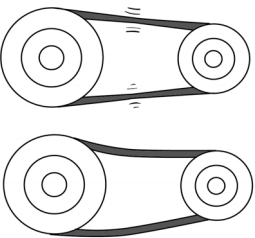
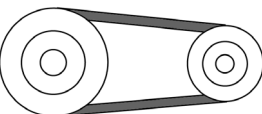
The table is intended to display the importance to use the original belts.

Case	Commercial grade belts	Original spare parts belts	Remarks
Fitness to pulleys. 	The belt shall rest with its angled sides against the pulleys. There must be a space between belt and pulley bottom.	The belt shall rest with its angled sides against the pulleys. There must be a space between belt and pulley bottom.	Same demands. Original belts guarantee that the belt fits against the pulleys.
Length	Manufactured in standard lengths in steps.. 	Manufactured in predefined lengths to fit between the pulleys.. 	The distance between the pulleys is fix. The belt tensioner gives the original belt an optimal tension.

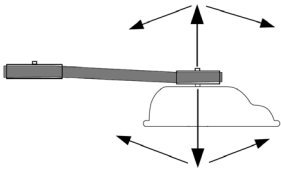
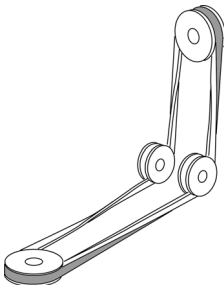
Edition	Manual	Chapter	Page
2008-10-17	Workshop Manual, Stiga Titan	5 Mechanical power transmissions	3

<p data-bbox="156 383 405 450">Floating pulley at the implement.</p> 	<p data-bbox="475 383 724 562">Designed to transmit power between aligned, parallel and fixed pulleys.</p>	<p data-bbox="770 383 1050 636">The original PTO belt is designed to operate, even if the pulleys are moving up and down and are tilting at the same time</p>	<p data-bbox="1090 383 1410 524">The implement follows the ground which involves that its pulley is constant moving.</p> <p data-bbox="1090 546 1410 725">To resist the excessive operating conditions, the original belts are made of fibre reinforced rubber.</p>
<p data-bbox="156 750 373 817">Bending in two directions</p> 	<p data-bbox="475 750 730 860">Designed to bend around pulleys in one direction only</p>	<p data-bbox="770 750 1050 1115">Most of the belts at the machine have tension rollers, actuating from the outside of the belt. This means the the belt has to bend both inwards and outwards during the operation.</p>	<p data-bbox="1090 750 1410 1039">All original belts which operate with tension rollers actuating from the outside have reinforcements. The reinforcement is special designed for the actual case.</p>
<p data-bbox="156 1137 245 1169">Noise</p> 	<p data-bbox="475 1137 730 1285">Manufactured without any special respect to the actual case.</p>	<p data-bbox="770 1137 1050 1397">The original belts are carefully selected to give the lowest noise increment to the machine during operation.</p>	<p data-bbox="1090 1137 1410 1285">Depending on the function of the belt, any of the following belt types are itemised:</p> <ul data-bbox="1090 1285 1299 1397" style="list-style-type: none"> • Wrapped • Non-friction • Raw-edge

Edition	Manual	Chapter	Page
2008-10-17	Workshop Manual, Stiga Titan	5 Mechanical power transmissions	4

5.2 PTO belt, 20B, 26B

5.2.1 Description

The PTO belt transmits the motor power to the articulating pulley via an electromagnetic clutch, PTO clutch. The belt is angled over two pulleys of which one is the tensioning pulley, fitted to a spring loaded lever. Such the belt is automatic tensioned.

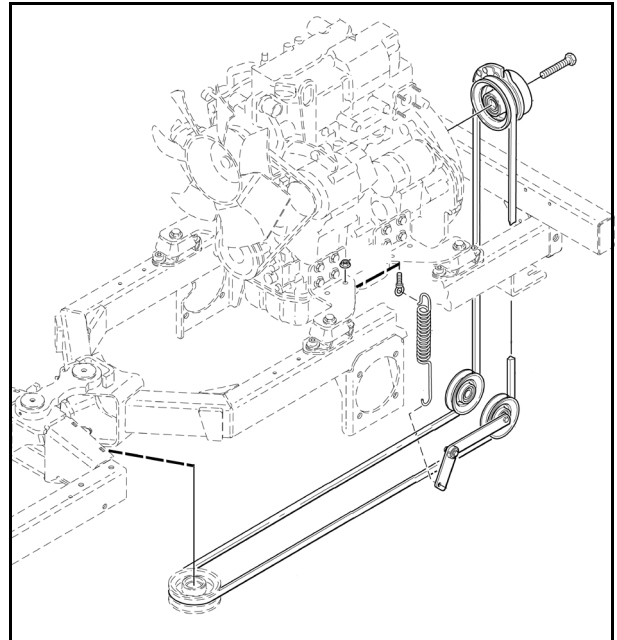

5.2.2 Disassembly

Dismantle the PTO belt as follows:

1. Dismantle all eventual implements from the machine. See the respective instructions.
2. Remove the rear motor hood (C):
 - Turn and remove the screws (A).
 - Unhook the straps (B).
 - Lift up and remove the hood (C).

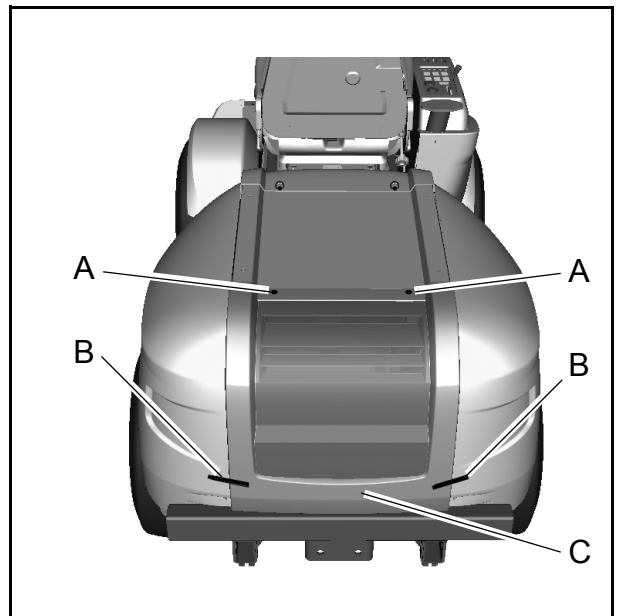

Edition	Manual	Chapter	Page
2008-10-17	Workshop Manual, Stiga Titan	5 Mechanical power transmissions	5

2. Slacken the belt by force the lever (D) backwards to rise the tension pulley (E). In this position, take off the belt from the pulley (E).
3. Remove the belt from the articulation point pulley.

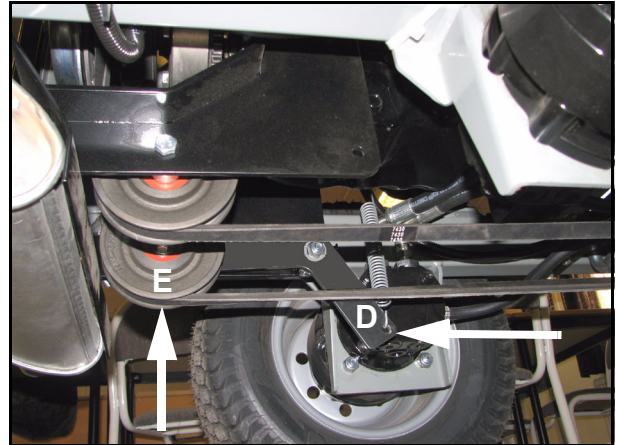

4. Remove the clutch locking screw (F) with its two nuts. Use two 13 mm spanners.
5. Disconnect the clutch cables (G).
6. Turn the clutch somewhat to the left and take out the belt.

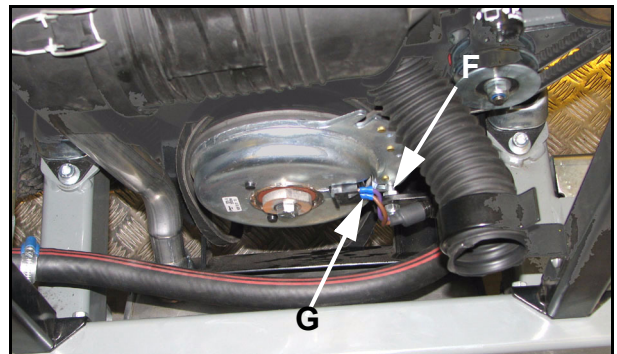

5.2.3 Inspections

Check the belt according to “2 Belt theory”.

Check the pulley bearings. All defective parts shall be replaced

Item	Check instruction
Bearing noise	Rotate the pulley and listen for abnormal noise and feel if any uneven resistance exists. If any abnormal noise is heard or if any uneven resistance exists shall the bearing be replaced.
Bearing play	Force the pulley radially. No radial play shall exist
Bearing sealings	Check visually the bearing sealings. All sealings shall be intact.

Edition	Manual	Chapter	Page
2008-10-17	Workshop Manual, Stiga Titan	5 Mechanical power transmissions	6

5.2.4 Assembly

Assemble all parts in the reverse order as follows:



Warning!

Never spill any oil on any belt. Oil on belts will destroy the friction and shorten the durability.

1. Lubricate the tension lever pivot point with machine oil.
2. Fit the belt to all pulleys without the tension pulley.
3. Fit the spring (H) to its eyebolt and hole in the lever.
4. Force the lever (D) backwards until pulley (E) have risen enough and apply the belt to the pulley.
5. Assemble the remaining parts.

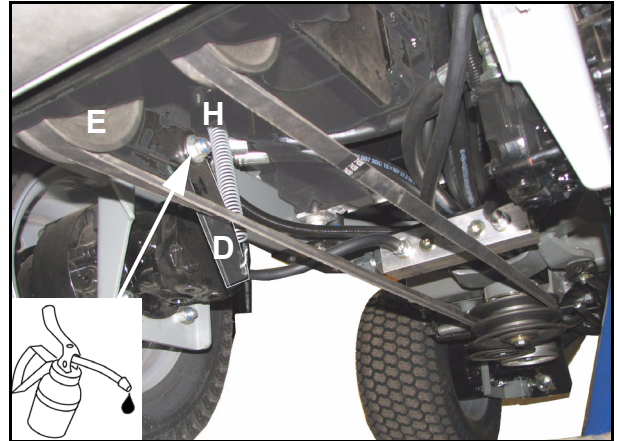

5.3 Hydraulic pumps belts, 20B, 26B

5.3.1 Description

The hydraulic pumps belts consist of two parallel belts which transmit the motor power to the driving system and external hydraulics pumps. The belts are automatic tensioned by a spring loaded lever with tensioning pulleys.

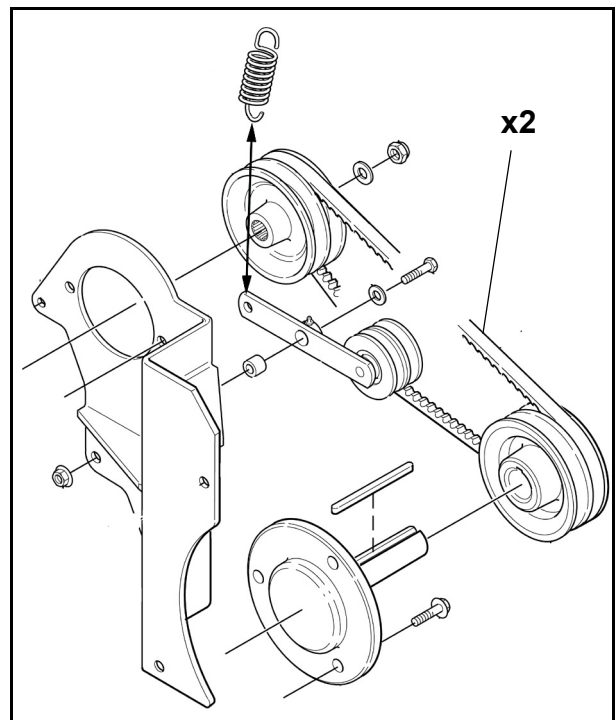

Edition	Manual	Chapter	Page
2008-10-17	Workshop Manual, Stiga Titan	5 Mechanical power transmissions	7

5.3.2 Disassembly

Dismantle the pumps belts as follows:

1. Dismantle the PTO belt. See “4 PTO belt, 20B, 26B”.
2. Remove the right motor hood.
3. Insert a screwdriver or similar and turn the lever to slacken the belts.



Warning!

Be carefully not to slip with the screwdriver. Risk for hand injuries.

4. Work off the belts from the tensioning pulleys while forcing the screwdriver downwards.
5. Work off the belts from the pump pulleys.
6. Remove the belts.

5.3.3 Inspections

Check the belt according to “2 Belt theory”.

5.3.4 Assembly

Assemble all parts in the reverse order:



Note!
The belts are delivered in a set of two belts which are matched together.

Never replace only one belt.

Never mix belts from different sets.

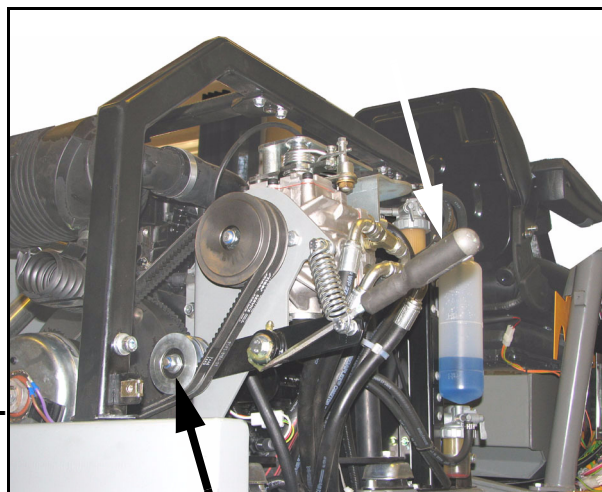

Edition	Manual	Chapter	Page
2008-10-17	Workshop Manual, Stiga Titan	5 Mechanical power transmissions	8

5.4 Hydraulic pumps belts, 26H, 26HS

5.4.1 Description

The hydraulic pumps belts consist of two parallel belts which transmit the motor power to the driving system and external hydraulics pumps. The belts are automatic tensioned by a spring loaded lever with tensioning pulleys.

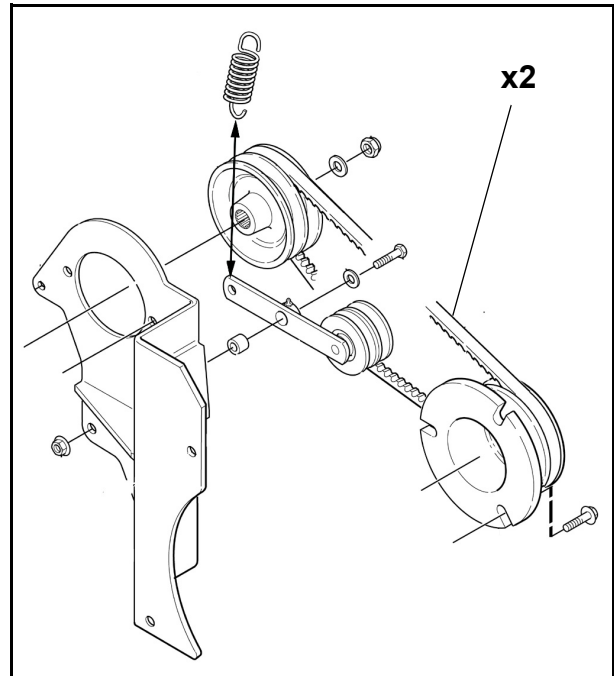

5.4.2 Disassembly

Dismantle the hydraulic pumps belts as follows:

1. Remove the rear motor hood (C):
 - Turn and remove the screws (A).
 - Unhook the straps (B).
 - Lift up and remove the hood (C).
2. Remove the right motor hood (D).

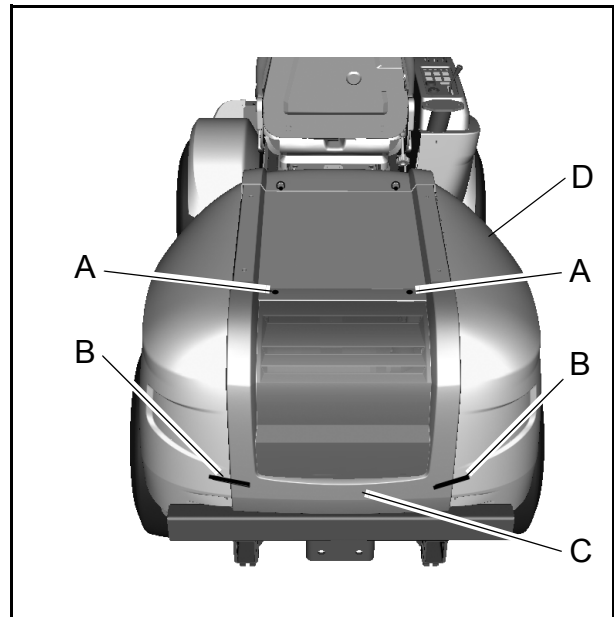

Edition	Manual	Chapter	Page
2008-10-17	Workshop Manual, Stiga Titan	5 Mechanical power transmissions	9

3. Insert a screwdriver or similar and turn the lever to slacken the belts.



Warning!

Be carefully not to slip with the screwdriver. Risk for hand injuries.

4. Work off the belts from the tensioning pulleys while forcing the screwdriver downwards.

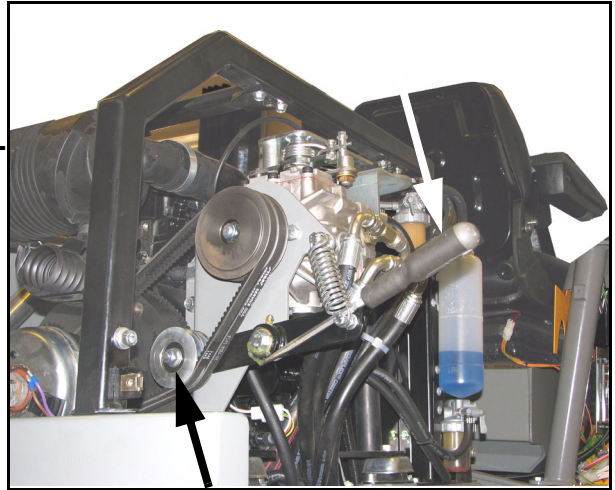

5. Unscrew the nut from the screw and remove the following parts, located under the pump:

- Nut (G)
- Distance (F)
- Screw (E)

Use two 17 mm keys

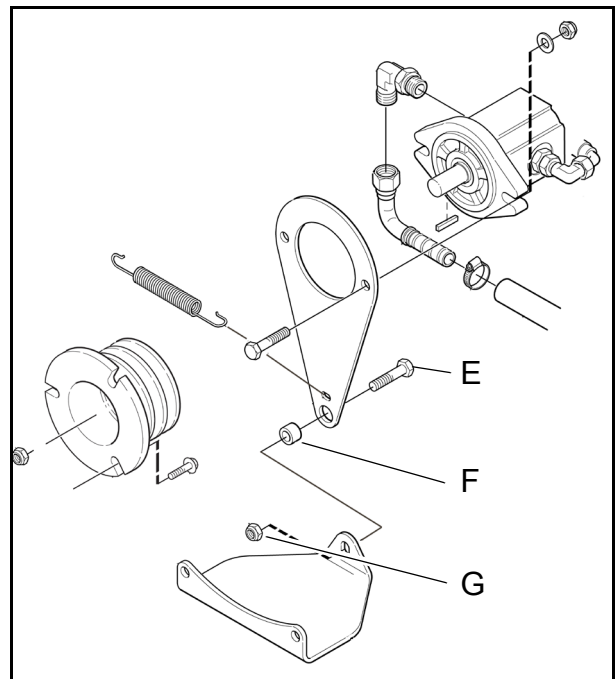

6. Unscrew the two upper screws and loosen the hose clamp and remove the air cleaner.

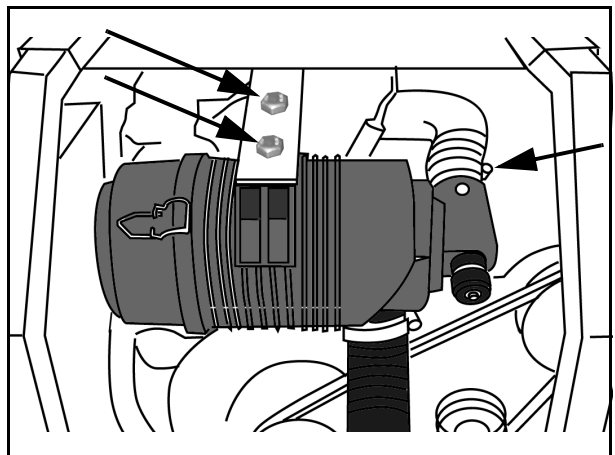

Edition	Manual	Chapter	Page
2008-10-17	Workshop Manual, Stiga Titan	5 Mechanical power transmissions	10

7. Unscrew the three M10 screws holding the carrier plate/pulley to the flywheel as follows:

- Block the flywheel with a screwdriver or similar when loosening the screws.
- Screw out all three screws half way in a first step.
- Thereafter, turn the flywheel once again and remove the screws.

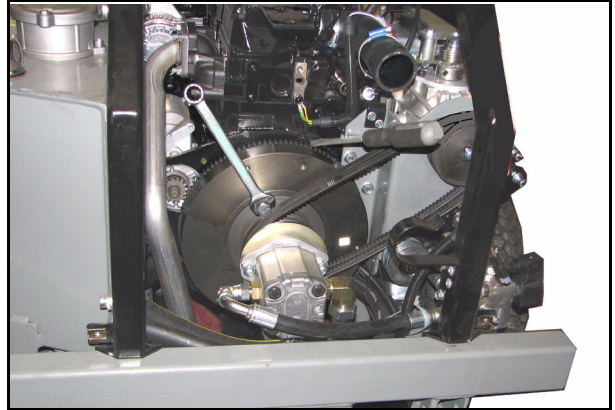

8. Pull out the pump with the carrier plate/pulley. Work off the belts and thread them between the carrier plate and the flywheel.

5.4.3 Inspections

Check the belt according to “2 Belt theory”.

5.4.4 Assembly

Assemble all parts in the reverse order:

- ! Note!
The belts are delivered in a set of two belts which are matched together.
Never replace only one belt.
Never mix belts from different sets.

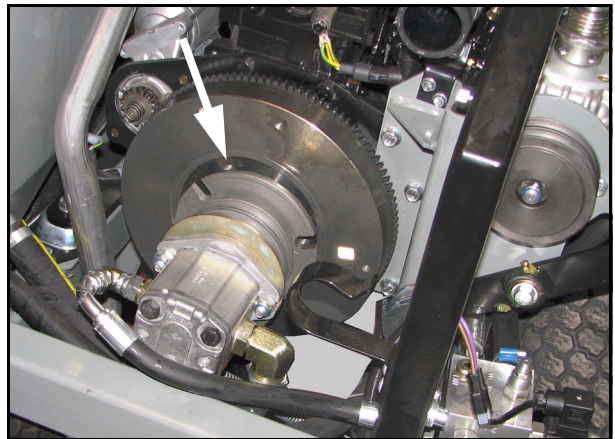

Edition	Manual	Chapter	Page
2008-10-17	Workshop Manual, Stiga Titan	5 Mechanical power transmissions	11

5.5 PTO pulley with bearing, 20B, 26B

5.5.1 Description

The PTO pulley is driven on its upper track via a belt from the motor. The PTO is performed from the lower track.

5.5.2 Disassembly

Dismantle the PTO pulley as follows:

1. Disassembly the PTO belt. See "4 PTO belt, 20B, 26B".
2. Unscrew the screw and take out the pulley assy. Use a 17 mm key.
3. Disassemble the shaft.

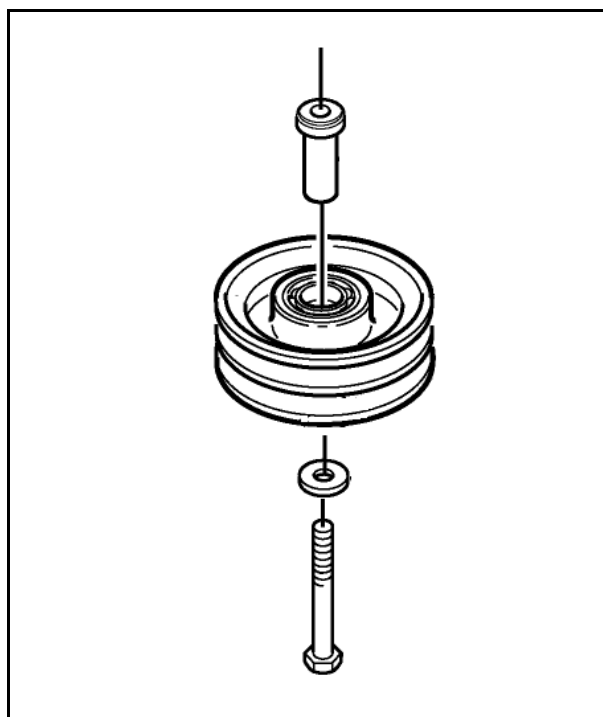
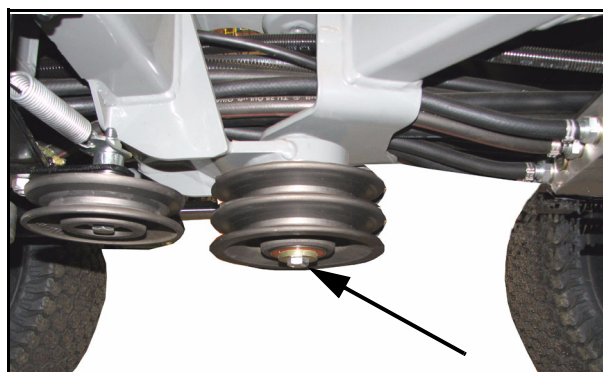

Edition	Manual	Chapter	Page
2008-10-17	Workshop Manual, Stiga Titan	5 Mechanical power transmissions	12

5.6 Checks

When all parts are disassembled, check the following items.

All defective parts shall be replaced.

Item	Check instruction
Bearing noise	Rotate the the bearing and listen for abnormal noise and feel if any uneven resistance exists. If any abnormal noise is heard or if any uneven resistance exists shall the bearing be replaced.
Bearing play	Force the inner ring radially. No radial play shell exist
Bearing sealings	Check visually the bearing sealings. All sealings shall be intact.

5.6.1 Assembly

All parts shall be assembled in reverse order. Note the following during the assembly:



Warning!

Never knock or press against the bearing inner ring. It will destroy the bearing before it is even used.

- If new bearings shall be assembled, use a press and press only against the bearing outer ring.
- Don't forget the bearing distance (D).

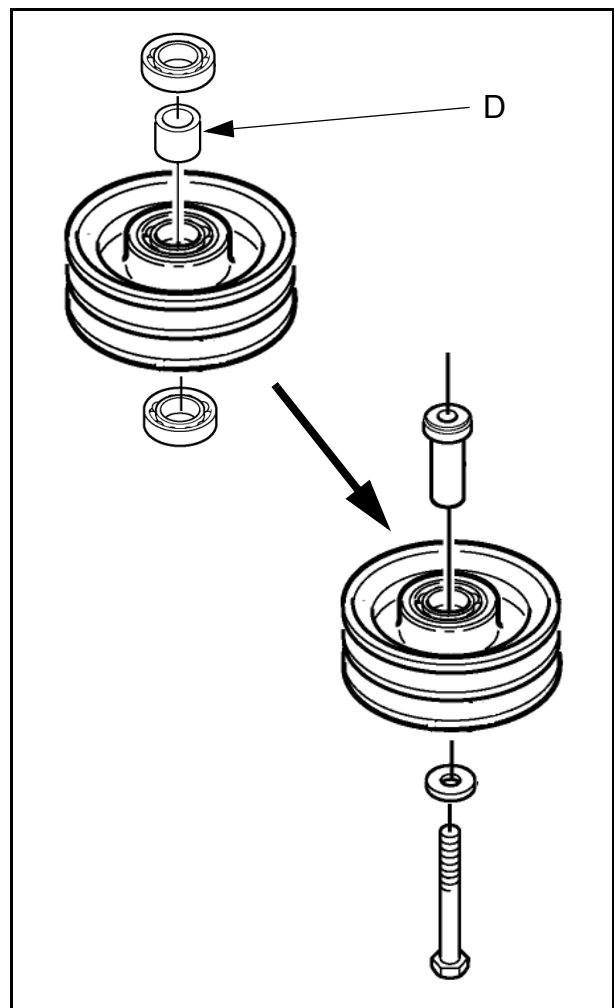

Edition	Manual	Chapter	Page
2008-10-17	Workshop Manual, Stiga Titan	6 Control wires	1

6 Control Wires

Contents in this chapter

6.1 Description	2	6.3 Brake wires	6
6.1.1 General.....	2	6.3.1 Description.....	6
6.1.2 Elbow links	2	6.3.2 Disassembly	6
6.1.3 Cable holders	2	6.3.3 Inspections.....	7
6.2 Drive wire	4	6.3.4 Assembly	7
6.2.1 Description	4	6.3.5 Adjustment.....	8
6.2.2 Disassembly	4	6.4 Throttle wire	8
6.2.3 Inspections	5	6.4.1 Description.....	8
6.2.4 Assembly.....	5	6.4.2 Disassembly	9
6.2.5 Adjustment	5	6.4.3 Assembly	10
		6.4.4 Adjustment.....	10

General

All the manoeuvring functions are incorporated on the control panel. This is an excellent solution in terms of ergonomics and comfort. It also simplifies the service work since all the controls and adjustments can be accessed in one place.

All mechanical control movements from the operator to the respective device on the machine are conducted by wires.

This chapter gives a brief description of the equipments and describes their repair and replacements.



Edition	Manual	Chapter	Page
2008-10-17	Workshop Manual, Stiga Titan	6 Control wires	2

6.1 Description

6.1.1 General

All wires consist of a wire and a conduit. In the wire ends one part, the wire or the conduit, is fastened to the body and the other part to a lever. The levers are connected to the operator control and to the controlled device. I.e. PTO wire, throttle wire, etc.

The wires are also in most cases fitted with adjustments sleeves with locking nuts or angle links at one or both ends.

Maintenance of wires:

Drop a little engine oil or lubricating spray in the ends of the control wires two or three times a year.

6.1.2 Elbow links

In many cases there are elbow links mounted at the wire ends. The elbow links have two functions as follows:

- To transmit the movement to/from the actual lever.
- For wire adjustment purpose. The wire tension is adjusted by screwing the link on/off the threaded rod at the wire.

! Note!
At the adjustment, at least 5 threads shall be engaged.

To change a elbow link

1. Loosen the nut (3) with a 8 mm wrench.
2. Remove the nut (1) with a 8 mm wrench. Hold the elbow stud with a 7 mm wrench.
3. Screw the elbow link off the rod.
4. The assembly is performed in the reverse order.
5. After the assembly, adjust the wire.

6.1.3 Cable holders



Warning!

It is essential that all cable holders are fitted properly. If not, there is risk of short circuit and fire.

All wires, electrical cables and other conductors are fitted to the chassis with cable holders. Always, after removal or replacement of wires, new cable holders shall be fitted in places where they were original mounted.

Loose wires and cables cause unnecessary wear of components which finally result in electrical short circuit, paint removal and damages of plastic covers etc.

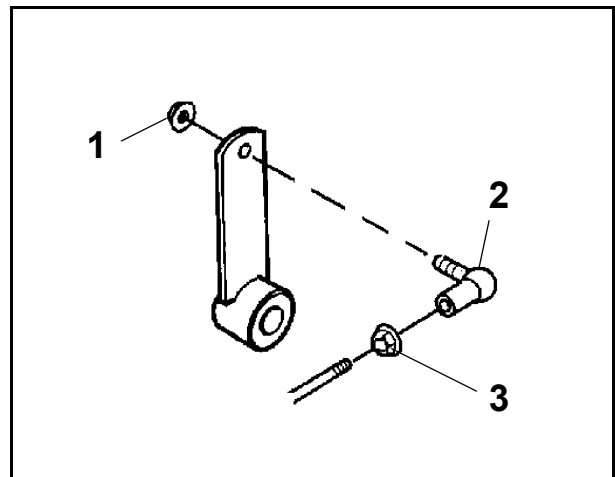

Edition	Manual	Chapter	Page
2008-10-17	Workshop Manual, Stiga Titan	6 Control wires	3

To apart a elbow link

1. Fold up the circlip (4) from the elbow link body.
2. Pull out the circlip.
3. Pry off the link body from the stud sphere by help of a screwdriver or similar.
4. The assembly is performed in the reverse order. The link body is pressed onto the sphere by help of a polygrip or similar.

! Note!
It is important that the circlip (4) is inserted in both holes in the elbow link body, otherwise the link will separate during operation.

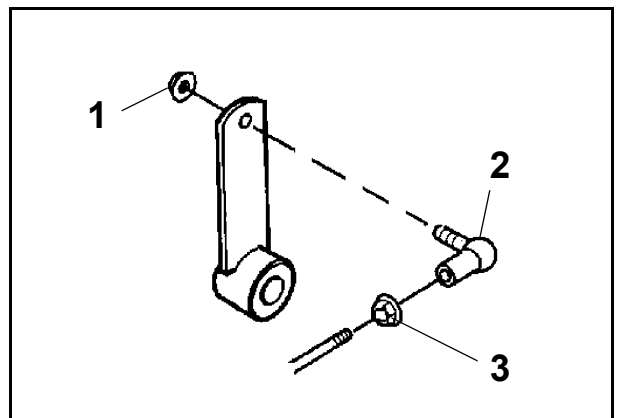
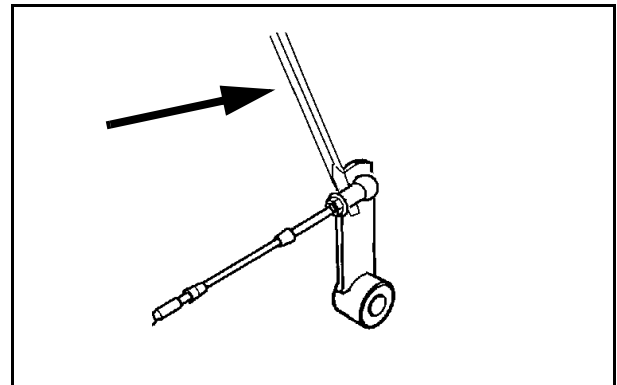
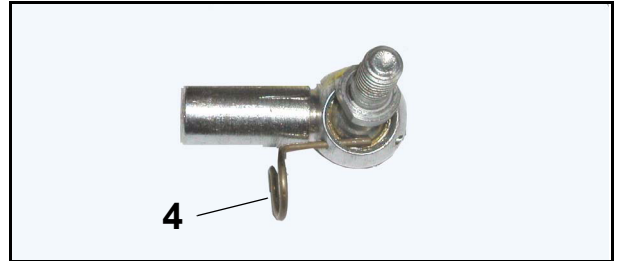

Adjustment

1. Loosen the nut (3) with a 8 mm wrench.
2. Apart the elbow link as described above.
3. Screw the link body in the desired direction on the wire stud. If necessary, move the nut (3) on the stud.
4. Check the adjustment result by pressing on the elbow link onto the sphere and without assembling the circlip.
5. After adjustment, assemble in the reverse order and tighten the nut (3) against the elbow link body.

! Note!
It is important that the circlip (4) is inserted in both holes in the elbow link body, otherwise the link will separate during operation.

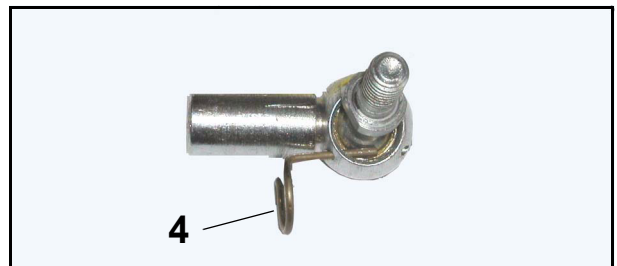

Edition	Manual	Chapter	Page
2008-10-17	Workshop Manual, Stiga Titan	6 Control wires	4

6.2 Drive wire

6.2.1 Description

The drive wire is intended to transmit the pedal movement to the pump lever. As the pedal also acts as service brake it is very important that the wire is moving easily in its conduit.

The wire transmits both pulling and pushing forces.

6.2.2 Disassembly

1. Loosen the wire and its conduit at the hydraulic pump. See "2.3 Cruise control".
2. Remove the floor mat and dismantle the front floor by unscrewing its four screws.
3. Loosen the wire and its conduit at the front end.
3. Loosen all attachment straps and remove the wire from the machine. Observe how the wire is located at the machine for the assembly purpose.

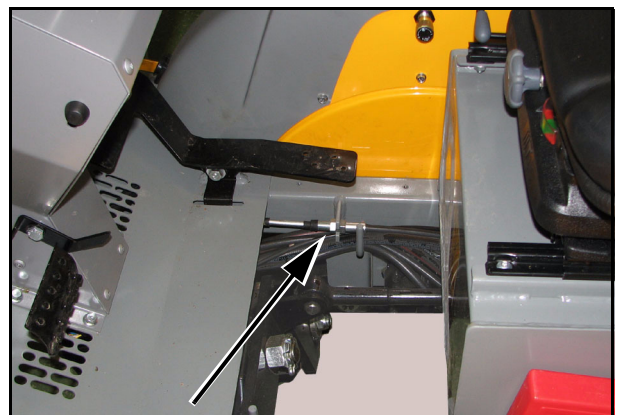
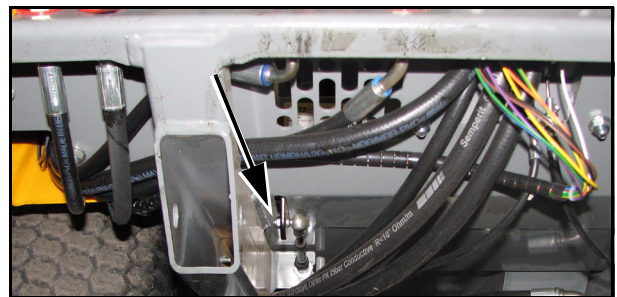
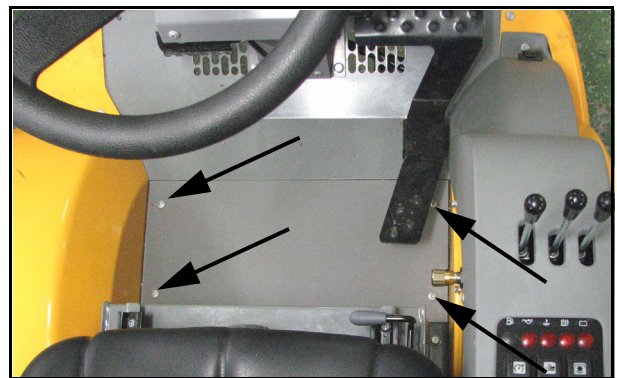
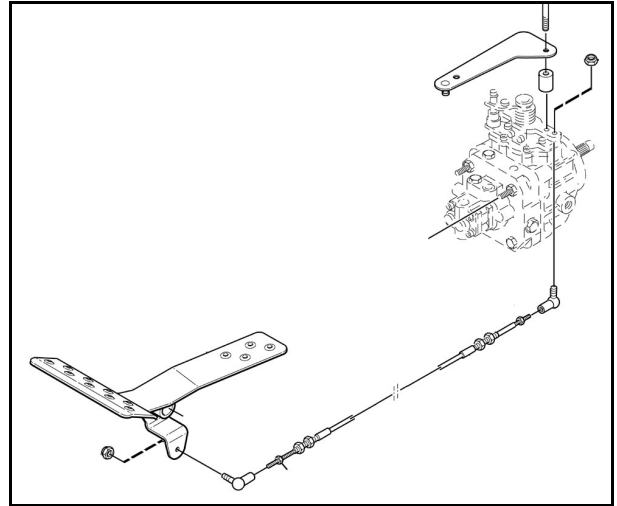

Edition	Manual	Chapter	Page
2008-10-17	Workshop Manual, Stiga Titan	6 Control wires	5

6.2.3 Inspections

- Check that the wire can be easily moved in its conduit during the entire stroke.
- Check that the conduit is free from sharp bends and other damages. The conduit outer cover must be intact to prevent water to enter the wire.
- Check that the conduit end sealings are intact.

6.2.4 Assembly

1. Lubricate the wire through its end sealings. Use machine oil. Slide the wire between its end positions until the oil has reached the entire wire.
2. Fit the wire to the machine as observed during the disassembly. See also the figure.
3. Adjust the wire. See below.

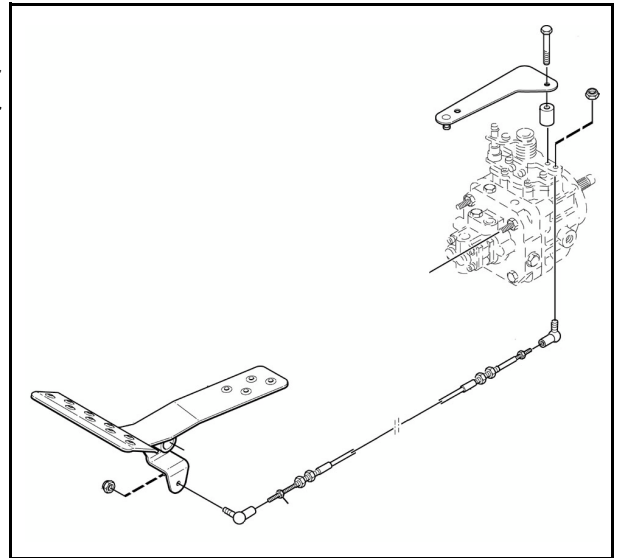

6.2.5 Adjustment

It is important that the drive wire is correct adjusted, otherwise the max backward/forward positions can not be reached and the wire is exposed for excessive stress.

Adjust the wire as follows:

1. Remove the right and top motor hoods.
2. Block the drive pedal in its max speed forward position. Use a piece of wood or similar.
3. Try to move the pump lever further inwards. It shall not be possible. If it is possible, adjust the wire conduit until the play is zero.

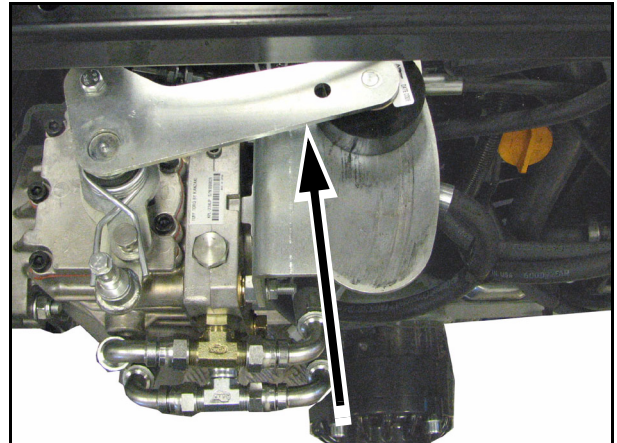

Edition	Manual	Chapter	Page
2008-10-17	Workshop Manual, Stiga Titan	6 Control wires	6

4. Block the drive pedal in its max speed backward position. Use a piece of wood or similar.
5. Try to move the pump lever further outwards. It shall not be possible. If it is possible, adjust the wire conduit until the play is zero.
6. Conclusion; No further play on the pump lever when the drive pedal is in its max positions.
7. Refit the motor hoods.

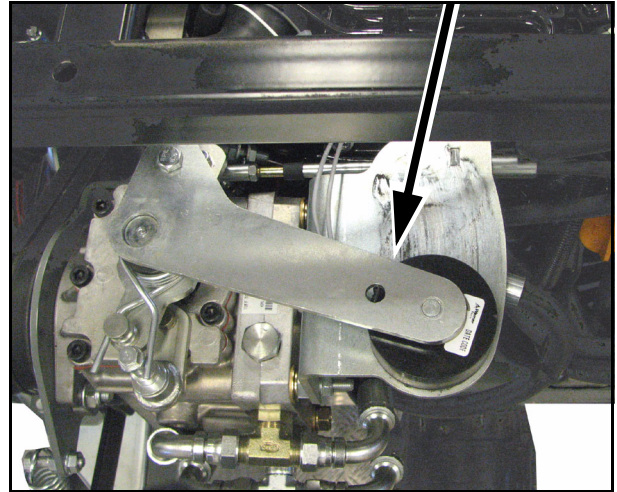

6.3 Brake wires

6.3.1 Description

The brake wires are transmitting the movement from the brake pedal lever to the front wheel motors brake lever. Since the brakes belong to the machine safety system, It is of great importance that the brake wires are faultless and correct adjusted.



Warning!

Never use a machine with faulty brakes.

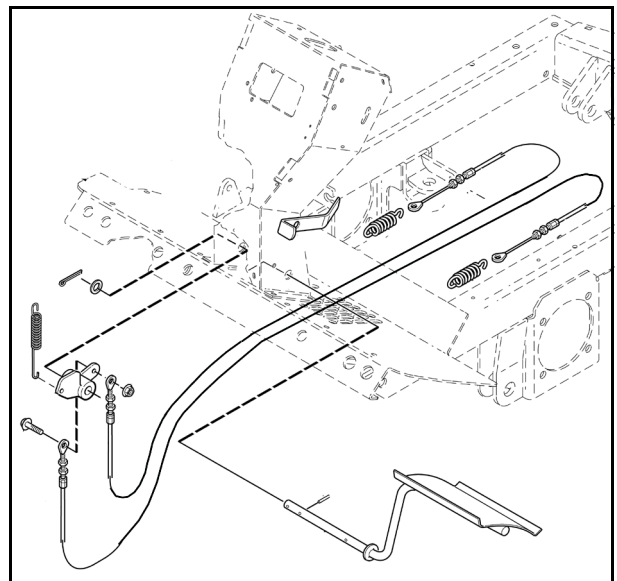

6.3.2 Disassembly

1. Dismantle the steering bracket rear cover by unscrewing the four screws.

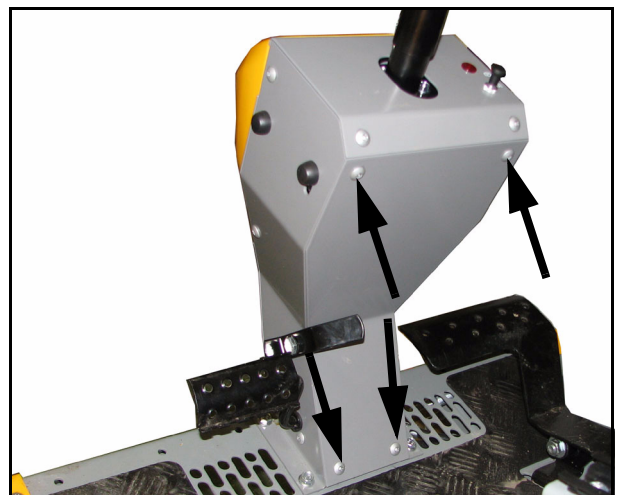

Edition	Manual	Chapter	Page
2008-10-17	Workshop Manual, Stiga Titan	6 Control wires	7

2. Loosen the wire attachment screw and release the wire ends.
3. Loosen the adjustment sleeve nuts and release the wire conduits.

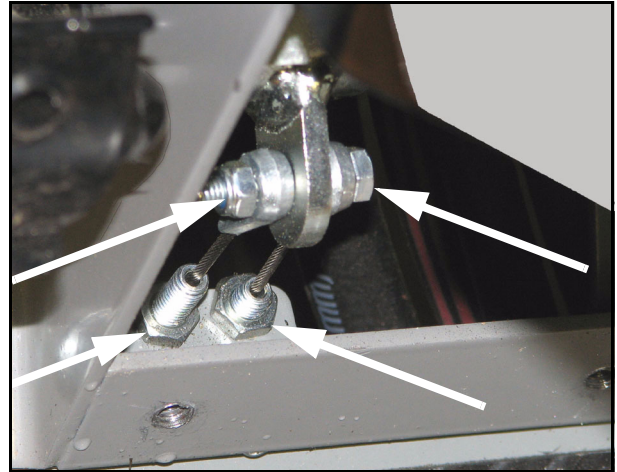

4. Loosen the wires under the machine by unscrewing the adjustment sleeve nuts and unhook from the springs.

6.3.3 Inspections

- Check that the wire can be easily moved in its conduit during the entire stroke.
- Check that the conduit is free from sharp bends and other damages. The conduit outer cover must be intact to prevent water to enter the wire.
- Check that the conduit end sealings are intact.

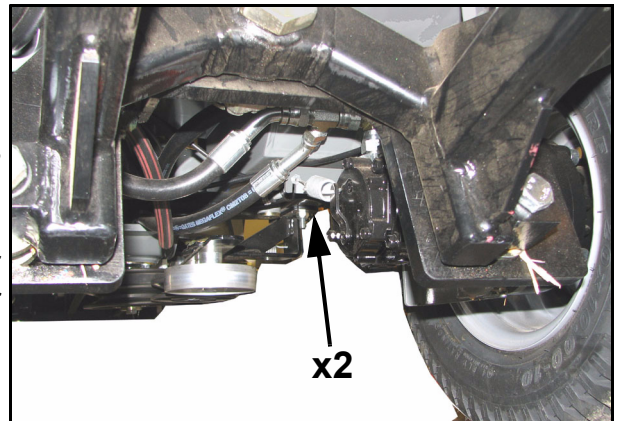

6.3.4 Assembly

1. Lubricate the wire through its end sealings. Use machine oil. Slide the wire between its end positions until the oil has reached the entire wire.
2. Fit the wire to the machine as observed during the disassembly. See also the figure.
3. Adjust the wire. See below.

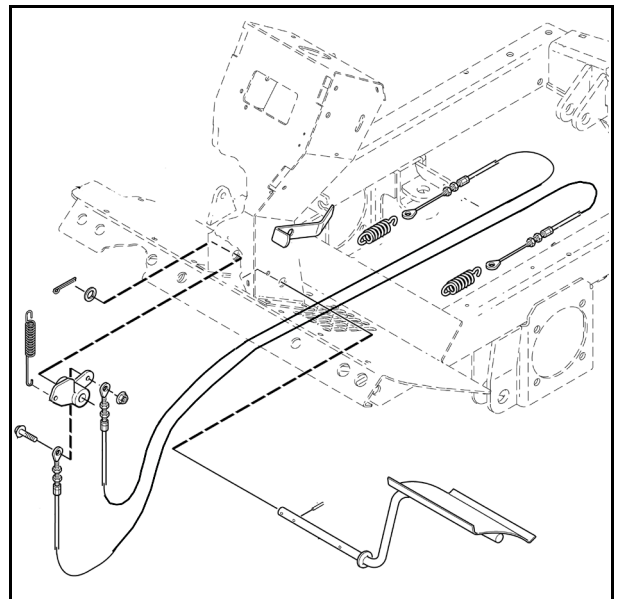

Edition	Manual	Chapter	Page
2008-10-17	Workshop Manual, Stiga Titan	6 Control wires	8

6.3.5 Adjustment



Warning!

Never use a machine with faulty adjusted brakes.

It is important that the brake wires are correct adjusted, otherwise the emergency brake / parking brak may not work correct.

Adjust the brake wires as follows:

1. Measure the spring length at not actuated brakes. The length shall be 56 mm.
2. Actuate and lock the brake.
3. Now, the spring length shall be 60 mm.
4. Adjust both wires at their adjustment sleeves until the measurement above is fulfilled.
Note! The wires can be adjusted in their both ends.
5. Lock the adjustment sleeves with their lock nuts after the adjustment.

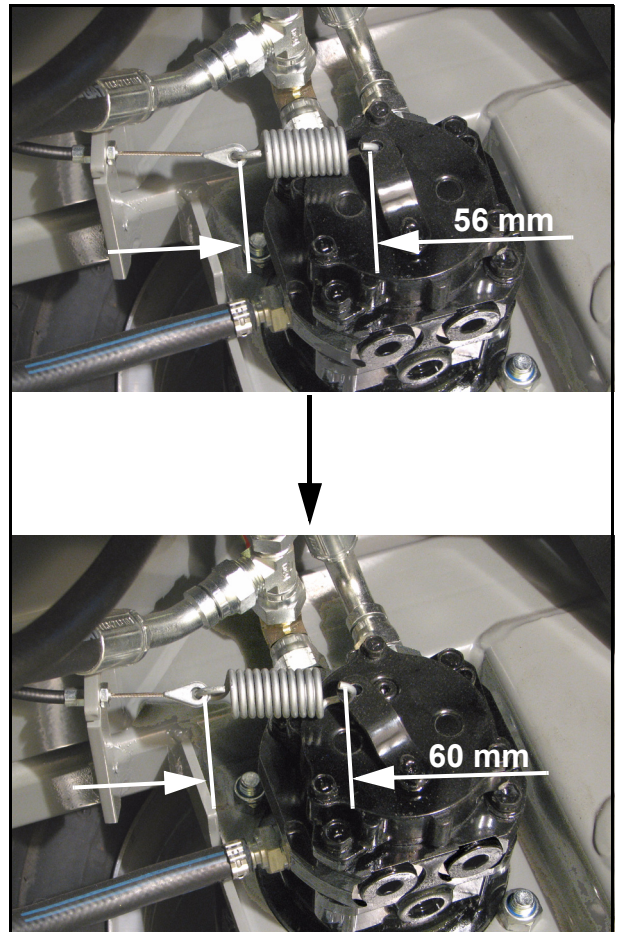

6.4 Throttle wire

6.4.1 Description

The trottle wire is integrated with the throttle lever and will be replaced as a complete unit.

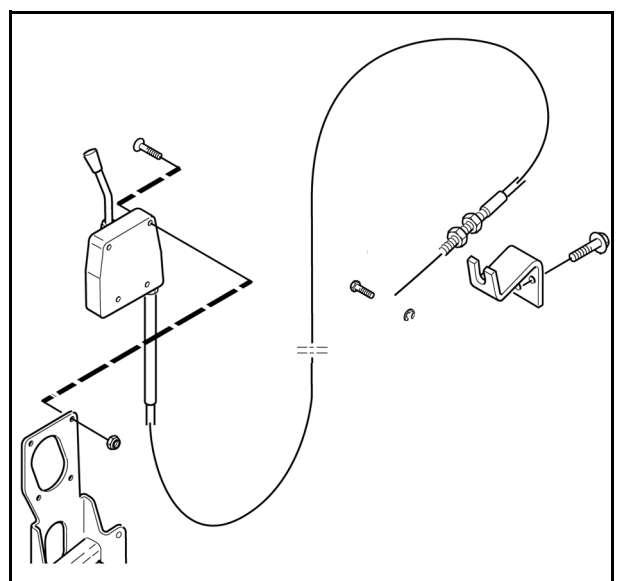

Edition	Manual	Chapter	Page
2008-10-17	Workshop Manual, Stiga Titan	6 Control wires	9

6.4.2 Disassembly

1 Disassemble the three lever knobs by unscrewing them and simultaneously pull them upwards.

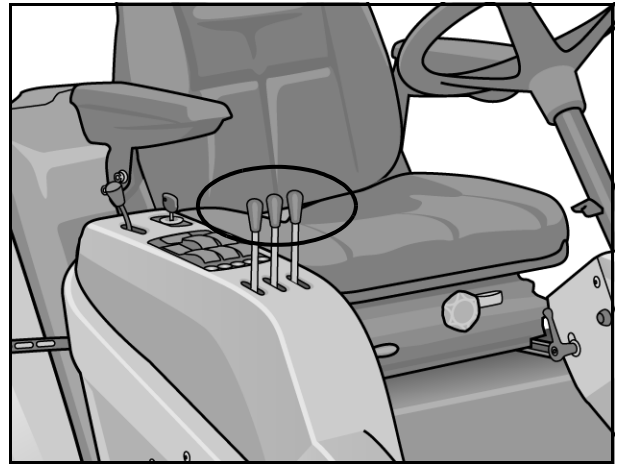

2. Remove the control panel casings by unscrewing the 11 screws in the figure.

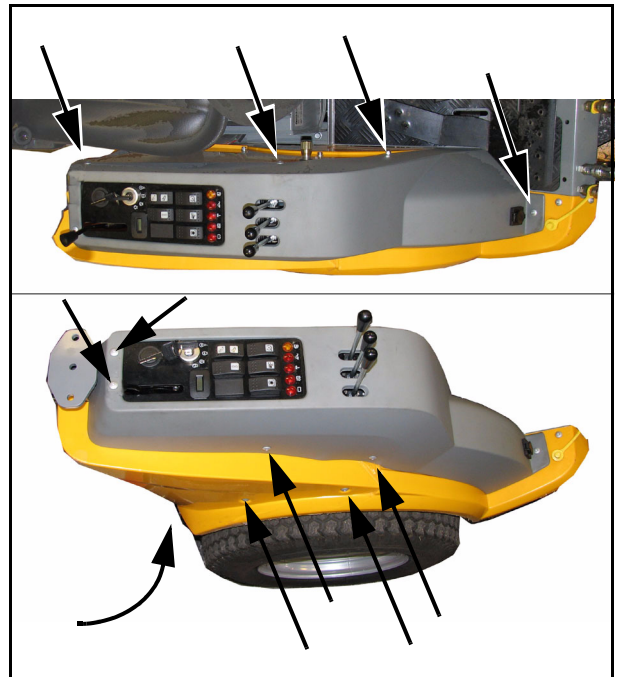

3. Disassemble the lever knob by unscrewing it and simultaneously pull it upwards.

4. Disassemble the four attachment screws with their nuts.

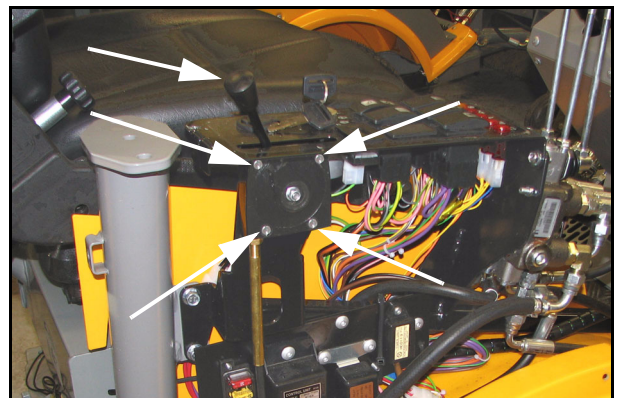

Edition	Manual	Chapter	Page
2008-10-17	Workshop Manual, Stiga Titan	6 Control wires	10

5. Disassemble the wire from the motor by loosen the conduit nuts and disassemble from the pump lever.
6. Observe the wire location in the machine and remove it, by drawing it forwards.

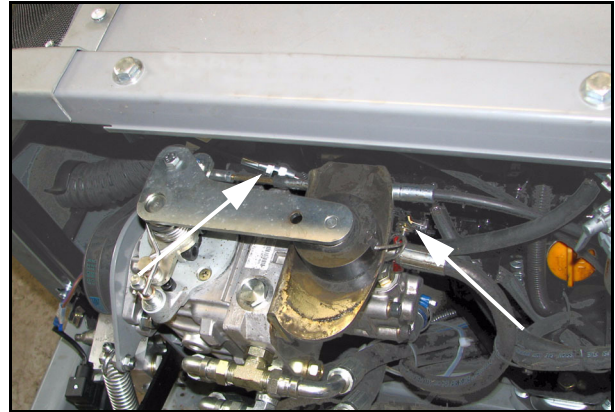

6.4.3 Assembly

1. Fit the wire to the machine as observed during the disassembly. See also the figure.
2. Assemble remaining parts in the reverse order.
3. Adjust the wire. See below.

6.4.4 Adjustment

It is important that the lever can set the pump lever in its end positions. Adjust the wire as follows:

- Set the throttle lever in full throttle position. In this position, it shall not be possible to move the pump lever further.
- Set the throttle lever in idle position. In this position, it shall not be possible to move the pump lever further against idle position.

Adjust the wire conduit nuts until the above is fulfilled.

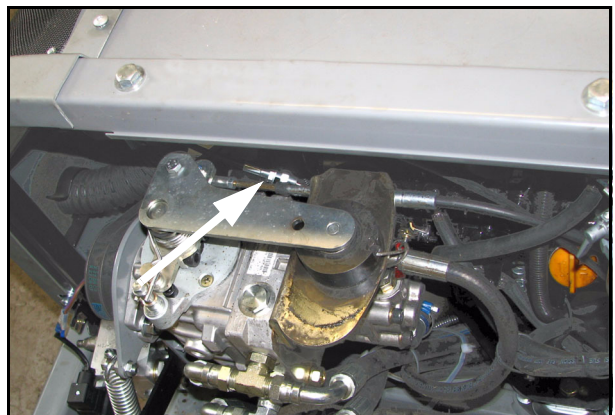
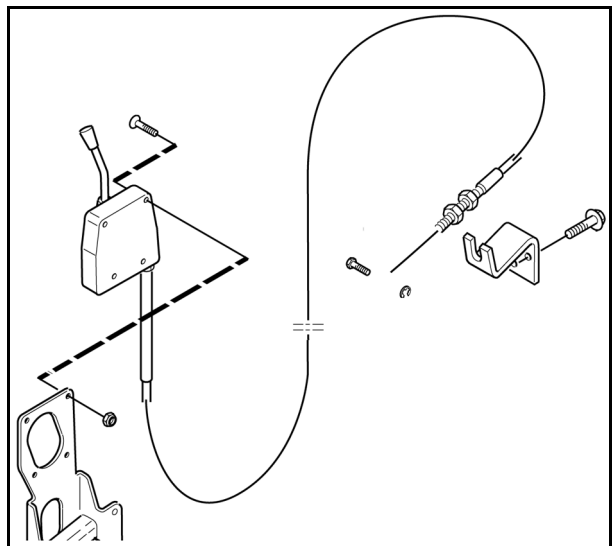



Edition	Manual	Chapter	Page
2008-10-20	Workshop Manual, Stiga Titan	7 Electrical System	1

7 Electrical System

Contents in this chapter

7.1 Description	2
7.2 Trouble Shooting	3
7.2.1 The starter does not rotate.....	4
7.2.2 The starter rotate but the motor do not start	5
7.2.3 The battery runs repeatedly empty	6
7.2.4 The motor does not stop	6
7.2.5 The speed cruiser does not work	7
7.2.6 The PTO does not work	8
7.2.7 The electrical cutting height adjustment does not work	9
7.2.8 The sand spreader does not work	9
7.2.9 The electrical rear height adjustment does not work.....	10
7.2.10 The motor can be started without the brake pedal pressed	10
7.2.11 The starter can rotate when the motor is running	10
7.3 Repair and replacements	11
7.3.1 Electrical compartment	11
7.3.2 Replacement of switches	12
7.3.3 Replacement of switch knob	12
7.3.4 Connections	13
7.3.5 Replacing headlamps	14

General

The electrical system has two main duties, to maintain the machine safety and to make the different functions easy to handle.

The main part of this chapter consists of trouble shooting of the electrical system to isolate faults and to give information about corrective measures. The electrical system is also described. There are also given instructions about general repair and replacement procedures.

Edition	Manual	Chapter	Page
2008-10-20	Workshop Manual, Stiga Titan	7 Electrical System	2

7.1 Description

The electrical components are connected with cables, integrated in two complete insulated harnesses, one front harness and one rear harness. The harnesses are connected at the articulating point with three 9-pole connector sockets. Thus the cables are protected against wear, contaminations and other stresses. The cables are connected to the actual components with tab or screw connectors and in some cases with multi-contact connectors.

The electrical system contains several safety circuits. Therefore actual levers and pedals are provided with micro switches. The micro switches are shown in the figure below. The signals from the micro switches are used to interlock the actual circuit in case of a forbidden manoeuvre attempt. Some manual switches and relays have also built in interlocks, related to the safety system.

The wiring diagrams are presented separately in the respective spare parts manual. To achieve a complete understanding of the electrical system for a certain machine, read also the actual wiring diagram.

All current consumption circuits except the start circuit are protected by fuses.

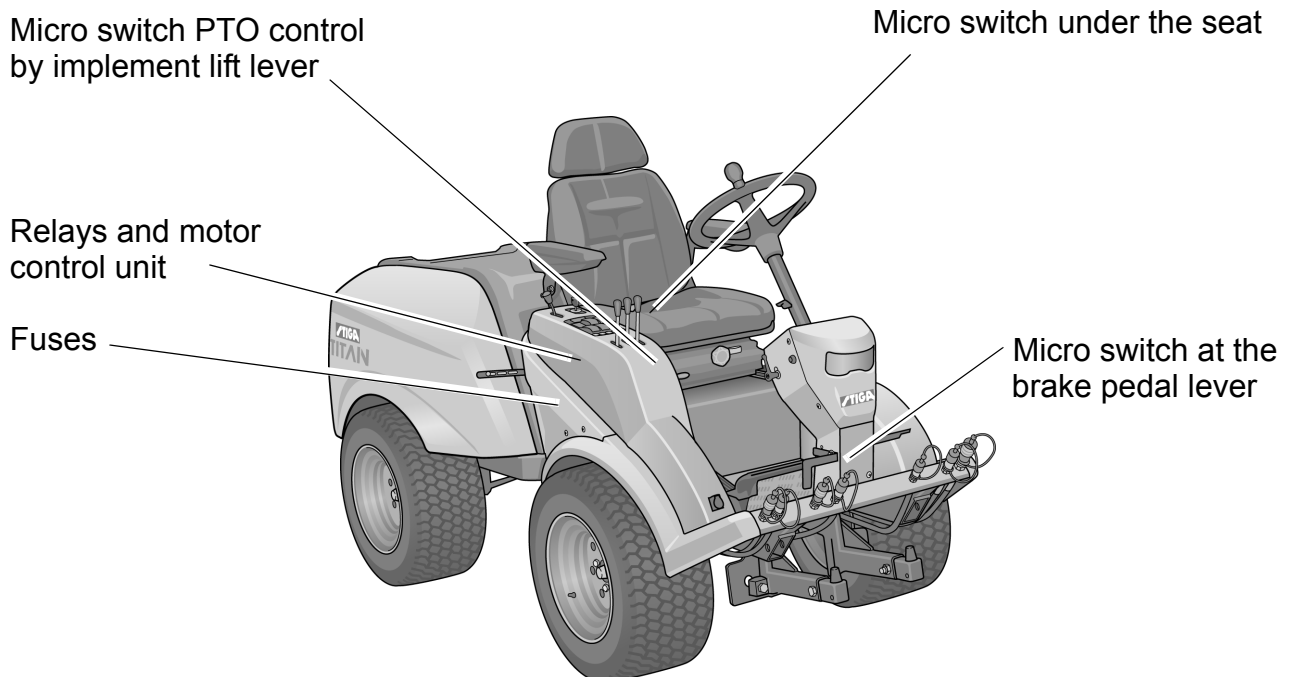

See also ““Repair and replacements” at page 11.

Edition	Manual	Chapter	Page
2008-10-20	Workshop Manual, Stiga Titan	7 Electrical System	3

7.2 Trouble Shooting



Warning!

Do not wear rings, metallic bracelet, chain round the neck or similar metal objects when working with the electrical system. It can cause short-circuit, burns and fire.

This section describes the trouble shooting procedures in absence of an electrical function. It also describes the correction measures in each actual case. When following the trouble shooting schedules, it is provided that the following states are fulfilled:

- All fuses are checked and, if necessary replaced.
- The battery shall be charged.
- The requirements for the actual measure shall be fulfilled. E.g. if it is advised to perform a start attempt, the operator shall sit down on the seat and press the brake pedal.

When following the trouble shooting schedules, it is in normal cases assumed that conductors and connectors to conductors are OK. However, in some cases, after a long period of use or in case of mechanical damages, the cables at the articulating point can be damaged. The circuit diagrams are presented in the respective spare parts manual.

Edition	Manual	Chapter	Page
2008-10-20	Workshop Manual, Stiga Titan	7 Electrical System	4

7.2.1 The starter does not rotate

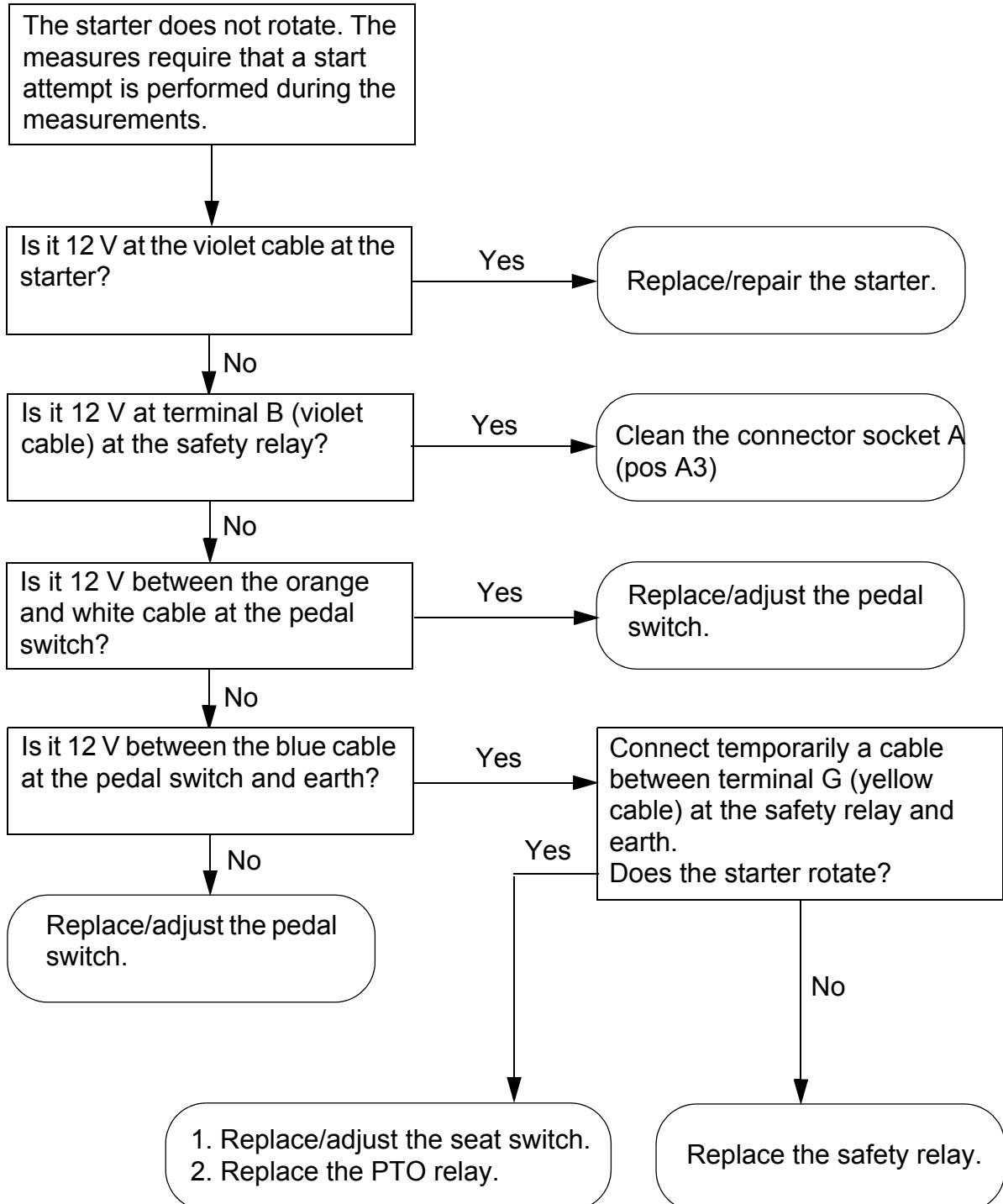

Edition	Manual	Chapter	Page
2008-10-20	Workshop Manual, Stiga Titan	7 Electrical System	5

7.2.2 The starter rotate but the motor does not start

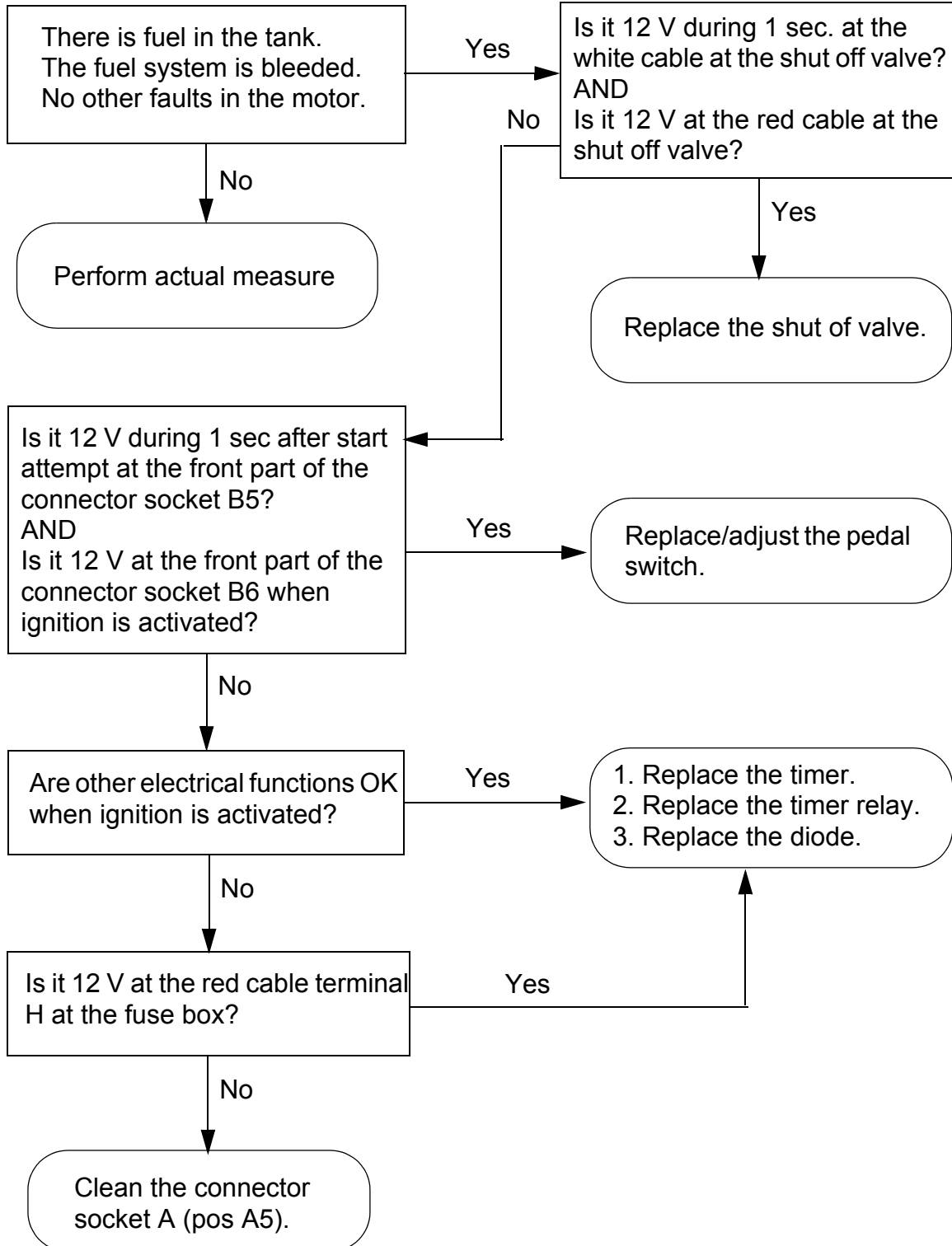

Edition	Manual	Chapter	Page
2008-10-20	Workshop Manual, Stiga Titan	7 Electrical System	6

7.2.3 The battery runs repeatedly empty

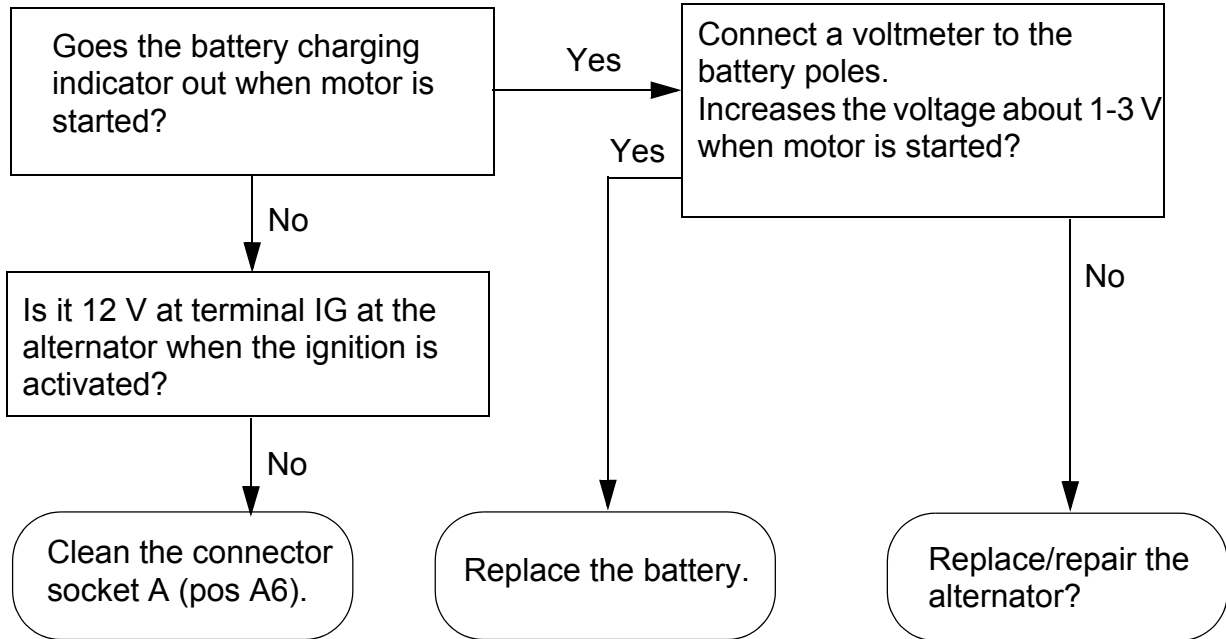

7.2.4 The motor does not stop

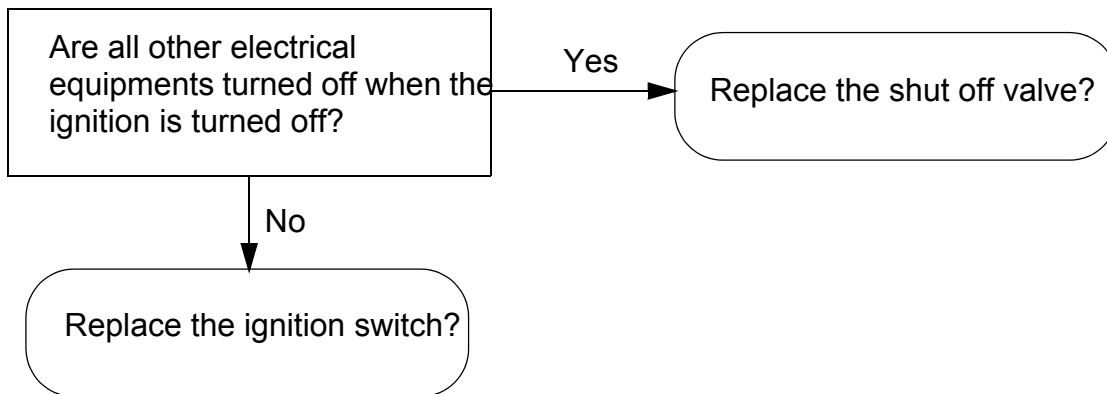

Edition	Manual	Chapter	Page
2008-10-20	Workshop Manual, Stiga Titan	7 Electrical System	7

7.2.5 The speed cruiser does not work

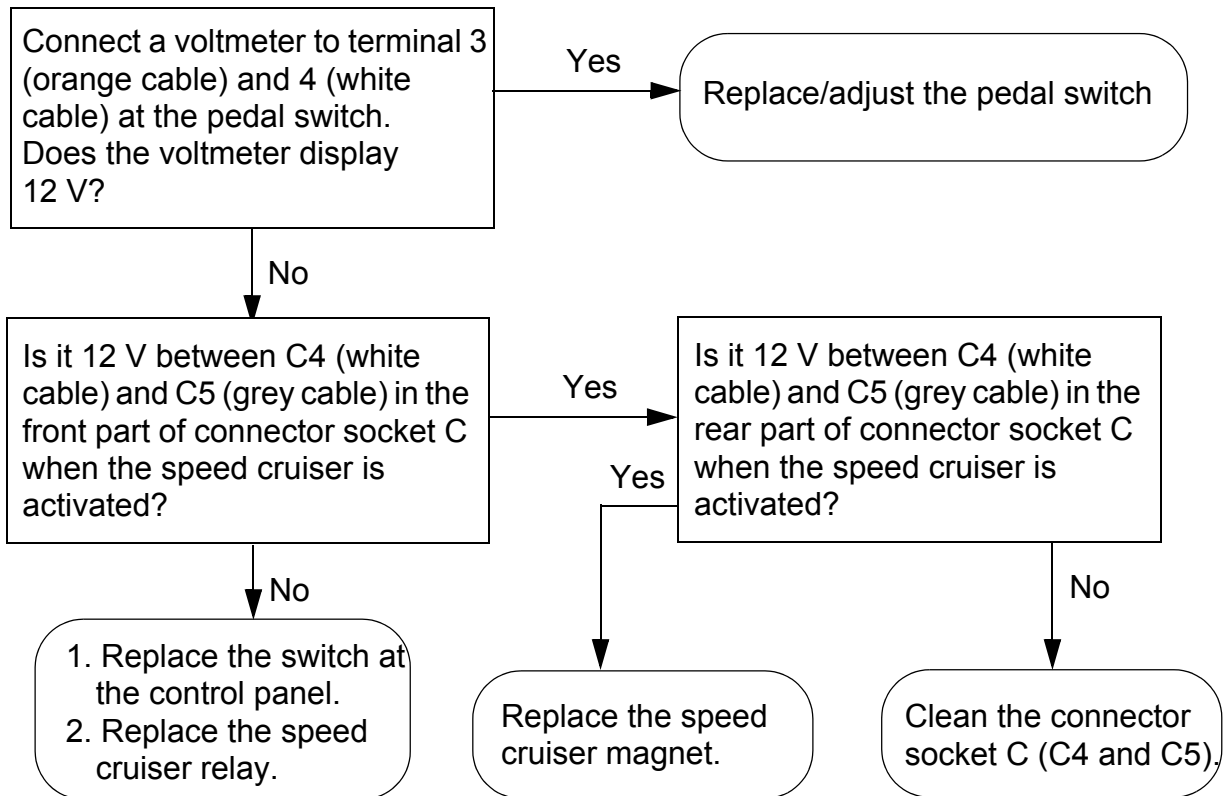

Edition	Manual	Chapter	Page
2008-10-20	Workshop Manual, Stiga Titan	7 Electrical System	8

7.2.6 The PTO does not work

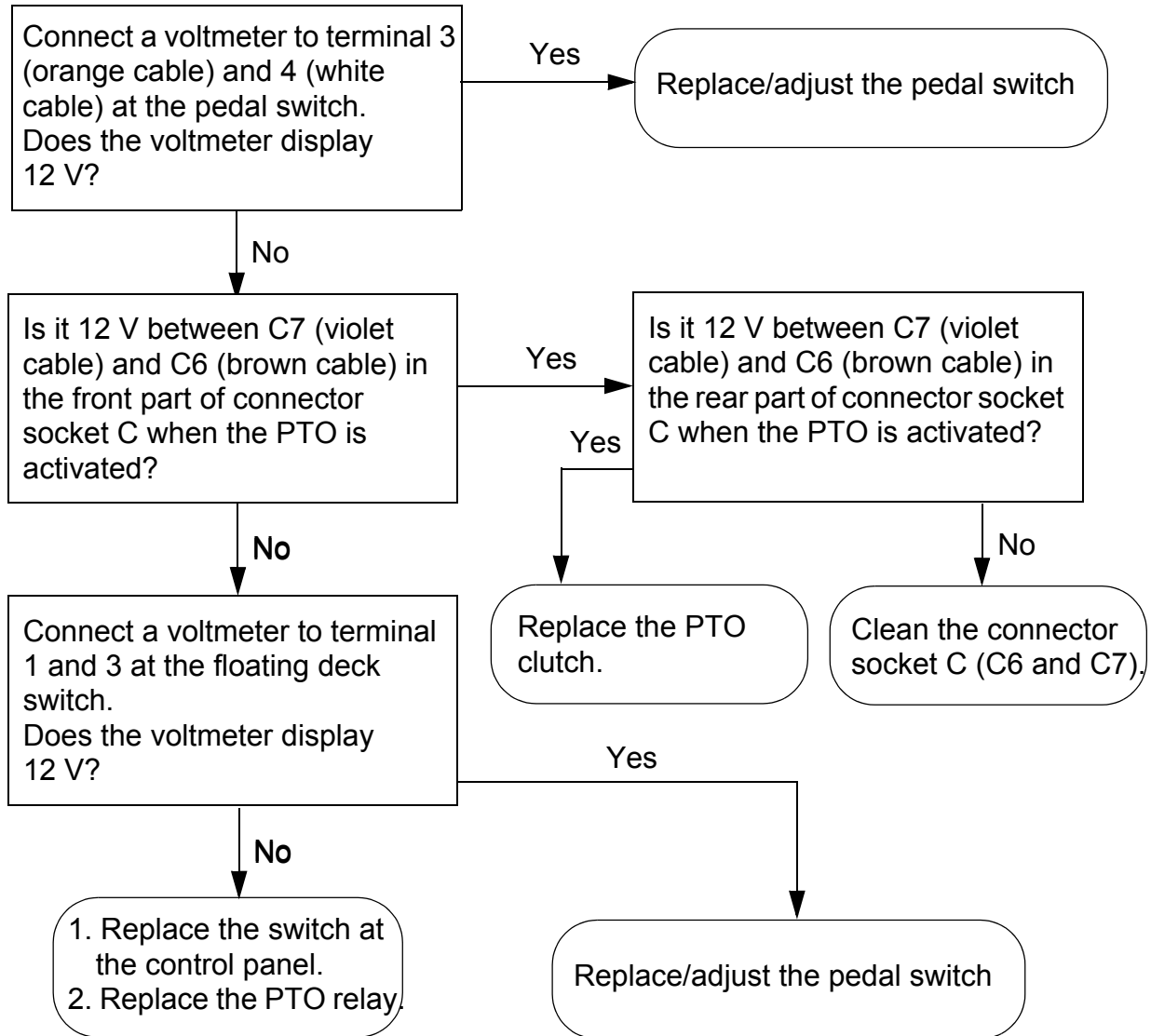

Edition	Manual	Chapter	Page
2008-10-20	Workshop Manual, Stiga Titan	7 Electrical System	9

7.2.7 The electrical cutting height adjustment does not work

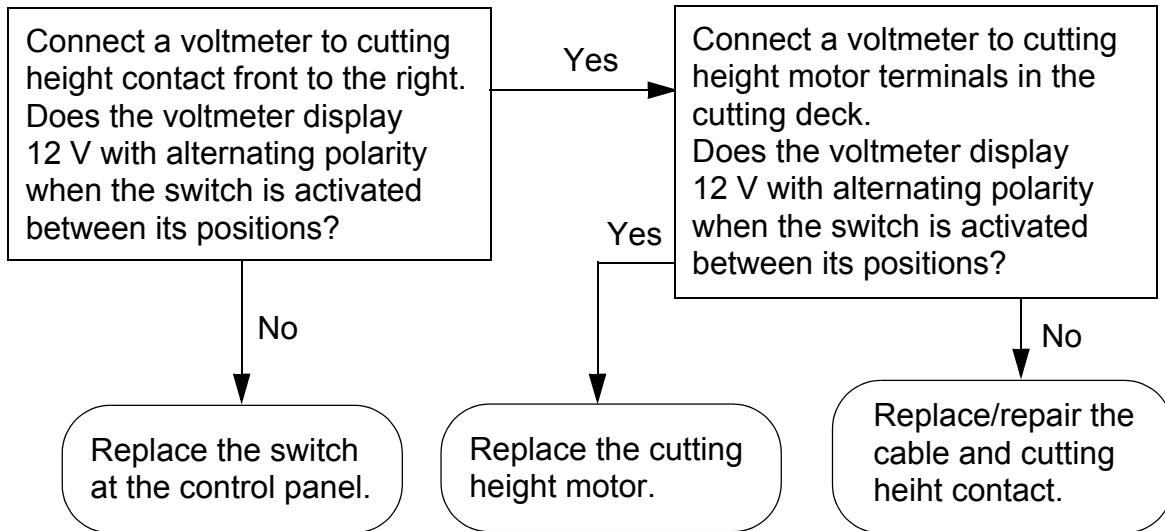

7.2.8 The sand spreader does not work

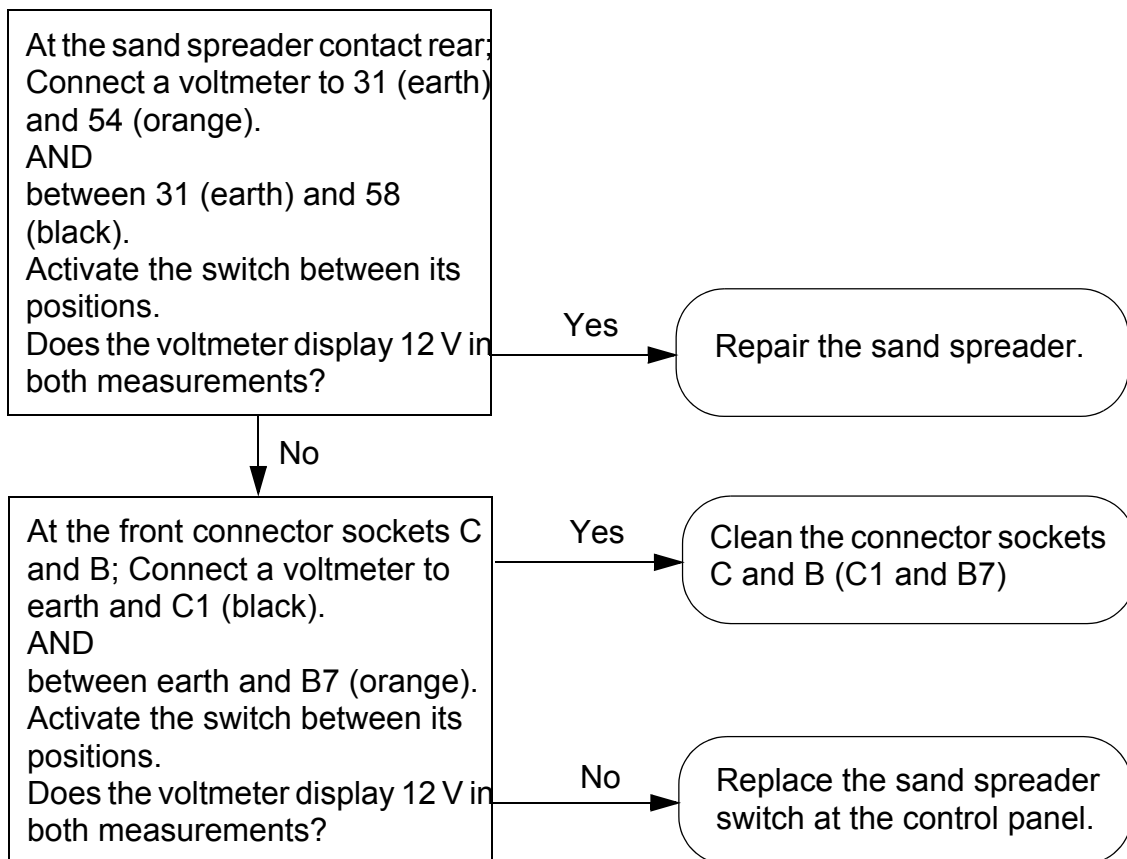

Edition	Manual	Chapter	Page
2008-10-20	Workshop Manual, Stiga Titan	7 Electrical System	10

7.2.9 The electrical rear height adjustment does not work

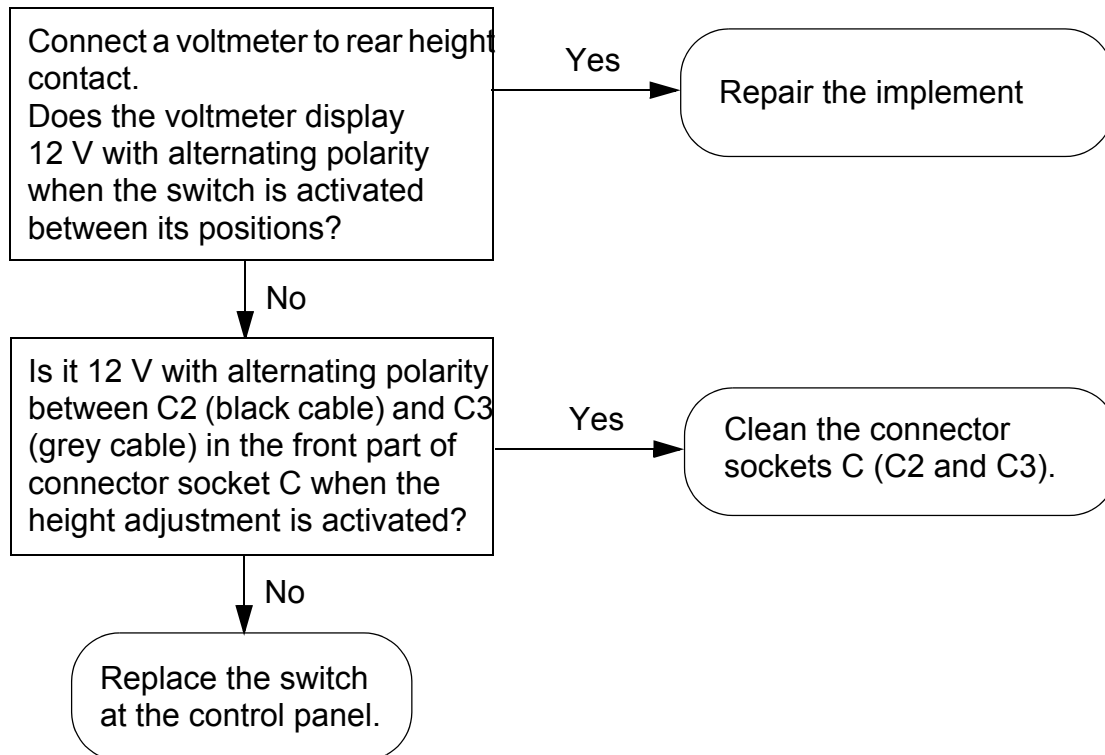

7.2.10 The motor can be started without the brake pedal pressed

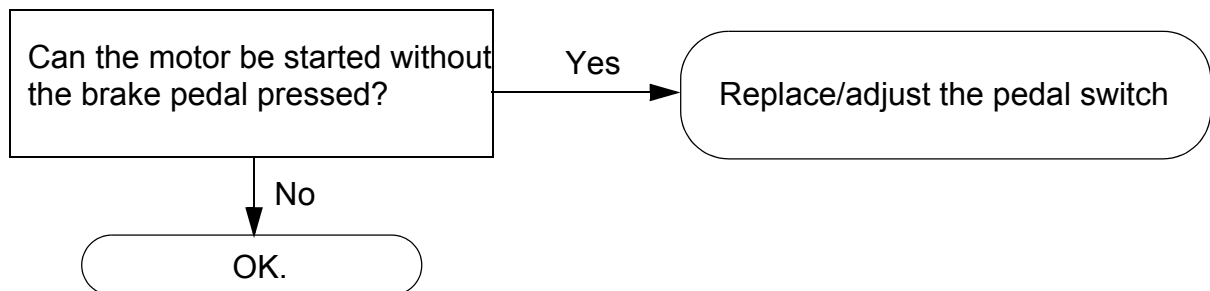

7.2.11 The starter can rotate when the motor is running

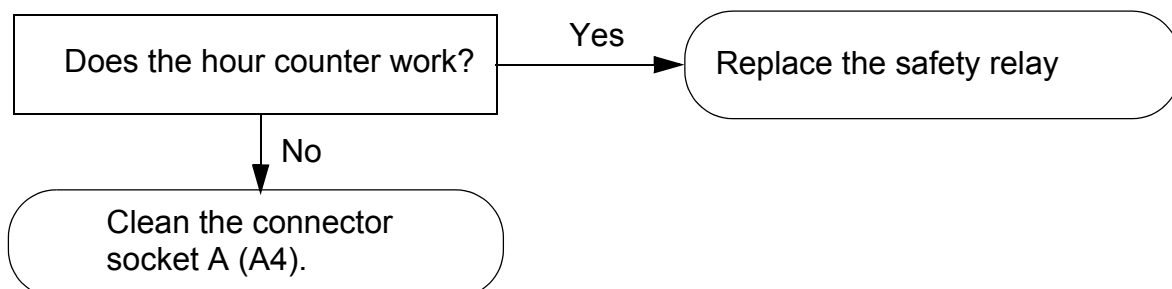

Edition	Manual	Chapter	Page
2008-10-20	Workshop Manual, Stiga Titan	7 Electrical System	11

7.3 Repair and replacements



Warning

Do not wear rings, metallic bracelet, chain round the neck or similar metal objects when working with the electrical system. It can cause short-circuit, burns and fire.

7.3.1 Electrical compartment

The main electrical components are accessible under the two casings at the control panel.

Get access to the electrical components as follows:

- 1 Disassemble the three lever knobs by unscrewing them and simultaneously pull them upwards.
2. Remove the casings by unscrewing the 11 screws in the figure.

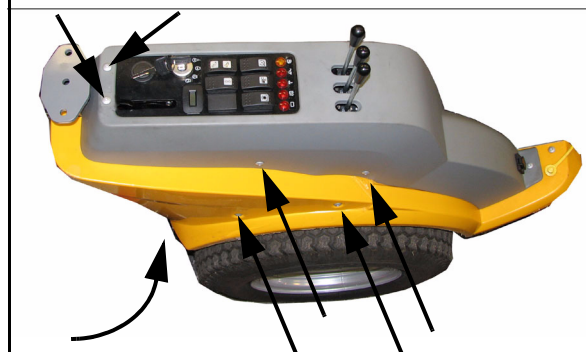
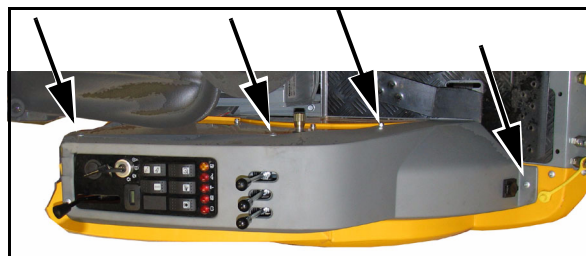
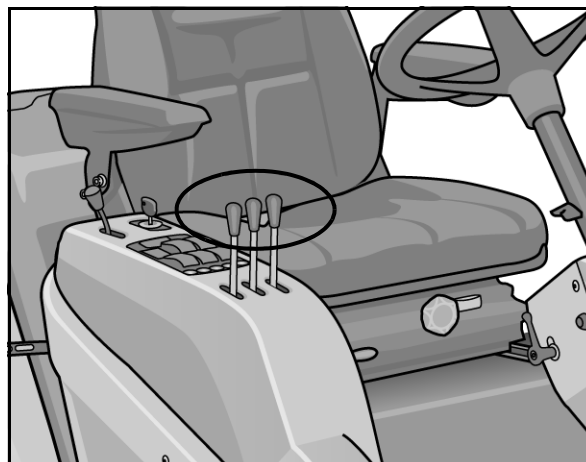

Relay locations:

The relays are located as follows:

- A. PTO relay and speed cruiser relay at the rear side of the plate. See the circuit diagram and compare cable colours to define the relays.
- B. Safety relay.
- C. Timer relay
- D. Timer

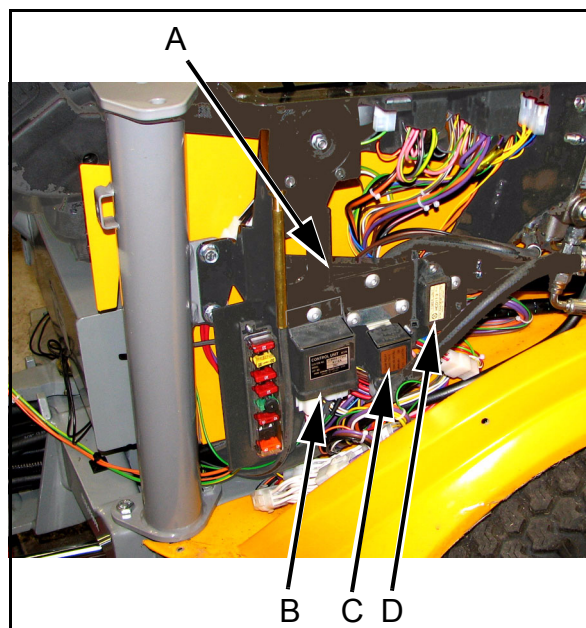

Edition	Manual	Chapter	Page
2008-10-20	Workshop Manual, Stiga Titan	7 Electrical System	12

7.3.2 Replacement of switches

All switches are pressed into place in their rectangular holes at the control panel. To change a switch proceed as follows:

1. Remove the actual cover to get access to the switch.
2. Press the fixation pig at the connector and pull the connector from the switch. See the figure. Some connectors have 2 pigs.
3. Press the fixation tongues on both sides of the switch against the switch. Use a screwdriver or similar and work up the switch. See the figure.

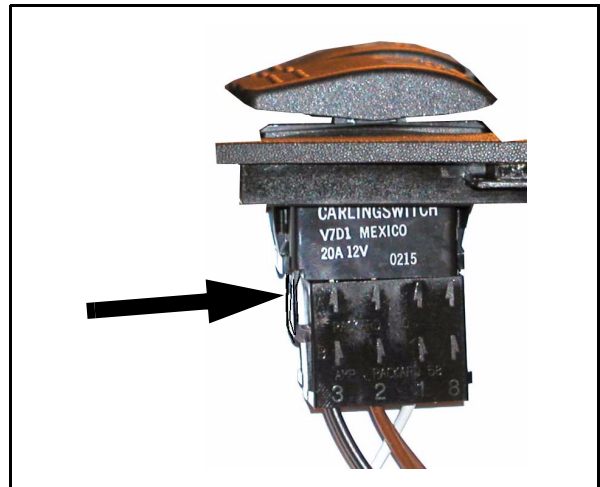

7.3.3 Replacement of switch knob

To replace the switch knob, there is a special tool available. Regarding reference number, see the spare parts list

Remove the knob by pushing in the tool backwards and press until the knob jumps up.

The knob is easily assembled by pressing it down in its hole in the switch.

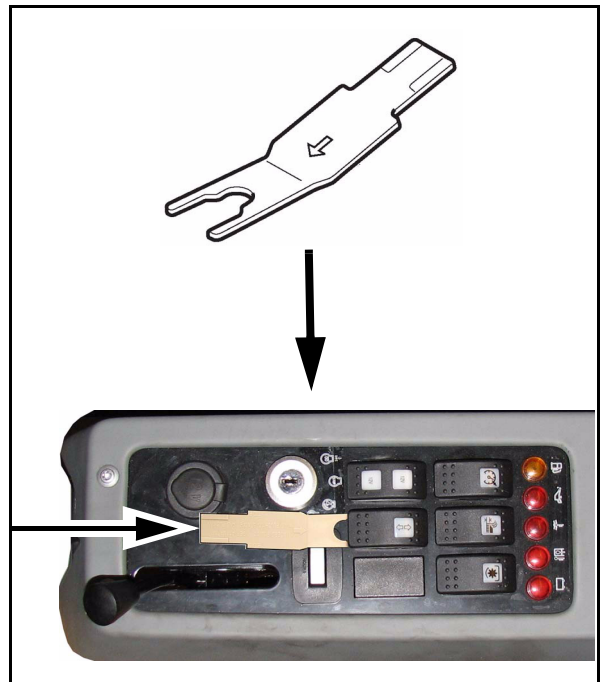

Edition	Manual	Chapter	Page
2008-10-20	Workshop Manual, Stiga Titan	7 Electrical System	13

7.3.4 Connections

The machine is equipped with three kinds of connectors:

- Fixed connectors in plastic holders.
- Tab connectors
- Screw connectors

All connectors shall be kept free from contamination, corrosion and damp.

Fixed connectors in plastic holders

To remove the connectors from the plastic holder, put a small screwdriver behind the connector, hold the cable and pull out the connector.

See the figure.

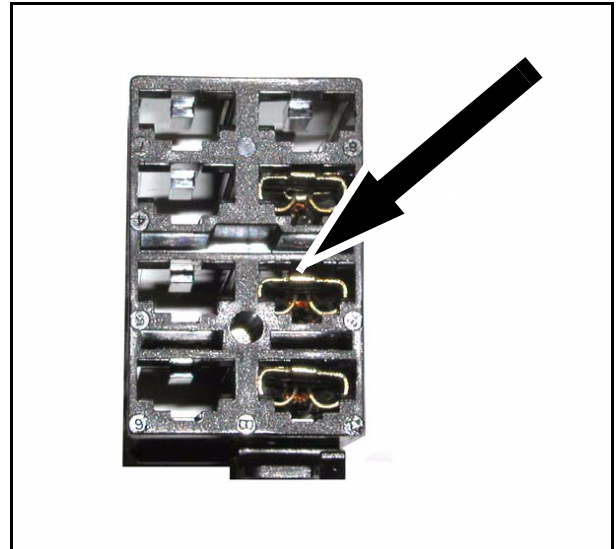

Tab connectors

To restore tab connectors if bad crimp forces occur, e.g. after a long time of use, the connector can be pinched by a pliers.

See the figure.

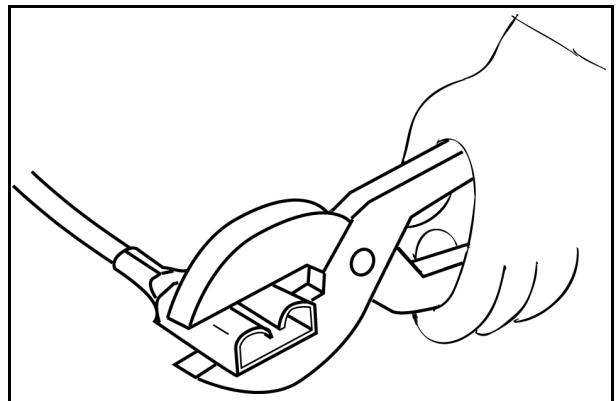

Screw connectors

When cables shall be connected into screw connectors, the cable shall be stripped off 5 mm only. No metallic conductor is allowed to be exposed outside the terminal.



Warning!
Exposed conductors can cause short-circuit and fire.

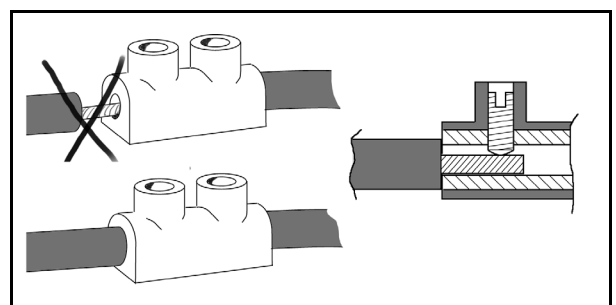

Edition	Manual	Chapter	Page
2008-10-20	Workshop Manual, Stiga Titan	7 Electrical System	14

7.3.5 Replacing headlamps

The machine is provided by two 12 V 20 W bulbs, apared 15° from each other. Replace the bulbs as follows:

1. Dismantle the front cover by unscrewing the four screws.
2. Replace the respective bulb by losening the two screws and disconnect the socket.
3. Reassemble the parts in the reverse order.



- ! Note!
Avoid to touch the bulb front with bare fingers. This will decrease the light intensity and shorten the bulb duration.

