

N...92

N...92 hydro

WORKSHOP MANUAL

Rel. 2.0

YEAR OF MANUFACTURE **2008**

The Manufacture reserves the right to make any improvements to the product of a technical or commercial nature that may be necessary. There may be, therefore, differences between the various series of machines and that described here, though the basic features and various repair methods will remain the same.

© by GLOBAL GARDEN PRODUCTS - No use of the illustrations or duplication, reproduction or translation, even partial, of the texts in this document may be made without explicit authorization.

CONTENTS

1. Rules and procedures for Service Centres

This chapter covers all the main aspects of the relationship between the manufacturer and the service centres.

A close collaboration between the manufacturer and the service centres is conclusive for solving problems in the most effective way as well as maintaining an image of efficiency and reliability. Compliance with these brief and simple guidelines will facilitate this task and prevent general misunderstandings and time-wasting for both the manufacturer and the service centre.

2. General and safety regulations

This chapter covers the main aspects of a servicing procedure and the general rules for guaranteeing a successful service which protects the environment and respects the safety of both the serviceman and the user of the apparatus.

3. Maintenance

This chapter deals with the criteria for routine maintenance.

4. Adjustments and tuning

This chapter deals with the adjustments to be made to remedy the more frequent performance failures and are usually resolved by quick checks and tunings.

5. Removal of external parts and main assemblies

For doing more difficult jobs, greater accessibility may be required. This can be done by taking the unit concerned off and working at the bench, or by removing the cover or other external parts. Whether or not this will be useful is at the discretion of the mechanic's experience.

6. Repairs

This chapter deals with all the more complex work connected with the replacement or repair of malfunctioning or worn parts.

The descriptions must follow a logical sequence and can include operations not specifically connected to a particular type of repair.

In this case, careful reading of the entire procedure can help you omit all those operations not connected with the case in hand without, however, overlooking anything that may be necessary.

7. Electrical system

This chapter deals with the problems and checks connected with the electrical system.

All work can be done using a tester without having to use special equipment.

The electrical diagrams can be useful to you for understanding how the system functions and to facilitate the pinpointing of any problems.

8. Technical specifications

This chapter summarises all the main information regarding the machine.

GENERAL INDEX

1.1	0	Identification and procedures
2.1	0	Safety regulations
2.2	0	Tools
2.3	1	Lifting
2.4	0	Vertical position
2.5	0	Practical hints
3.1	0	Criteria for maintenance
4.1	0	Adjusting the engagement and checking thr blade brake
4.2	0	Brake adjustment
4.3	0	Drive belt adjustment

INDEX

i
1

from 2007 to
page 2 / 2

- 4.4 0 Drive pedal adjustment (► *Hydrostatic drive models*)
- 4.5 0 Aligning the cutting deck
- 4.6 0 Adjusting the steering play
- 4.7 0 Steering geometry adjustment
- 4.8 0 Checking blades alignment
- 4.9 0 Removing, sharpening and balancing the blades

- 5.1 0 Removal of front hood
- 5.2 0 Removal of wheels cover
- 5.3 0 Removing the ejection conveyor
- 5.4 0 Removing the tank and replacing the fuel pipe
- 5.4a 1 Removing the tank (front type) and replacing the fuel pipe
- 5.5 0 Removal of the engine
- 5.6 1 Removal of the rear axle
- 5.7 0 Removal of the cutting deck

- 6.1 0 Replacement of tyres and wheels
- 6.2 0 Replacement of front wheel bearings
- 6.3 0 Dismantling of the steering components
- 6.4 1 Replacement of the drive belt
- 6.5 0 Replacement of the small wheels for the drive belt
- 6.6 1 Replacement of the blades belt
- 6.7 0 Replacement of the supports and shafts of the blades
- 6.8 0 Replacement of the accelerator
- 6.9 0 Replacement of the brake pads and disc (► *Mechanical drive models*)

- 7.1 1 Guide to the identification of problems in the electrical system
- 7.2 1 Summary table for the cutting in of the safety devices
- 7.3 0 Safety microswitches and switches operation check
- 7.4 0 Terminal board supply check
- 7.5 0 Electromagnetic clutch operation check
- 7.6 0 Starter relay operation check
- 7.7 0 Electronic card operation check
- 7.8 0 Recharge circuit check
- 7.9 0 Care and maintenance of the sealed battery
- 7.10 0 Fitting safety microswitches
- 7.11 1 Electrical diagrams

- 8.1 0 Tightening torques and adjustments summary
- 8.2 0 Summary of main assembly amounts and checks

INTRODUCTION

This manual has been compiled to help Service Centres with the maintenance, dismantling and repair of the following versions of the J92 lawn-tractor:

- mechanical drive with gear box;
- hydrostatic drive (hydro).

Each page of this manual states the following information:

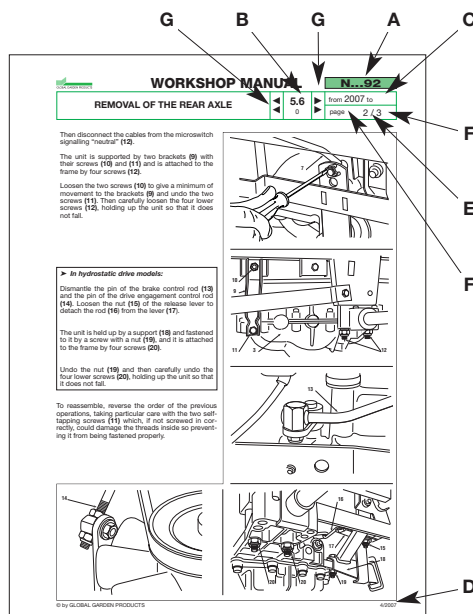

- A)** Machine or machine series to which the page applies.
- B)** Page number, specifically:
 - the first two figures separated by a point indicate the section and the chapter
 - the third figure indicates the modification index.
- C)** Temporary validity of the page, with reference to the year of manufacture or serial numbers.
- D)** Date of release.
- E)** Page number and total number of pages dedicated to the subject.
- F)** Any previous or ensuing pages dedicated to the subject.
- G)** Any chapters before or after the current one.

The manual refers to the following symbols:

Warns of operations that should be carried out with utmost care to avoid impairing the functionality and safety of the lawnmower.

Warns of operations that should be carried out with utmost care to avoid injury to the operator.

Reference to another procedure or part of the manual.

This symbol highlights all those operations that require different working methods depending on the type of machine, subsequent modifications or accessories fitted.

NOTE
Whenever a reference is made to a position on the machine "front", "back", "left" or "right" hand side, this is determined by facing the direction of forward travel.

The manual has left out the simplest and quickest operations that can be handled by a good mechanic, while concentrating more on specific aspects and the best servicing procedures.

You are asked to read through this manual to acquire a basic understanding of the machine, which is necessary for working rationally without making errors or wasting time.

All problems related to use are fully covered in the user manual.

1.1 IDENTIFICATION AND PROCEDURES

A) Identification

1) Machine

Each machine has a label attached **(1)** under the driver's seat which shows the technical specifications, the model and the serial number.

The model and serial number must be shown on each repair sheet when requests are made under guarantee, and are indispensable for spare part orders.

2) Transmission (Rear axle)

The transmission unit (both mechanical and hydrostatic) is made up of an engine block including the rear axle. This unit is made by another manufacturer to our precise technical specifications which differentiate it from similar items by this same Manufacturer.

The serial number on the label (2) clearly identifies the product and its specifications. This number must always be quoted when requesting spare parts or any information from the Manufacturer.

3) Engine

The engine is made to precise technical specifications which differentiate it from similar items by this same Manufacturer.

The serial number on the label clearly identifies the product and its specifications. This number must always be quoted when requesting spare parts or any information from the Manufacturer.

B) Guarantee validity

The guarantee is supplied under the terms and the limits of the contractual relations in being. As far as the engine and the transmission unit are concerned, the conditions given by their respective manufacturers apply.

C) Service repairs after guarantee period

The Service Centre has to make out a report containing the machine's serial number, a summary of

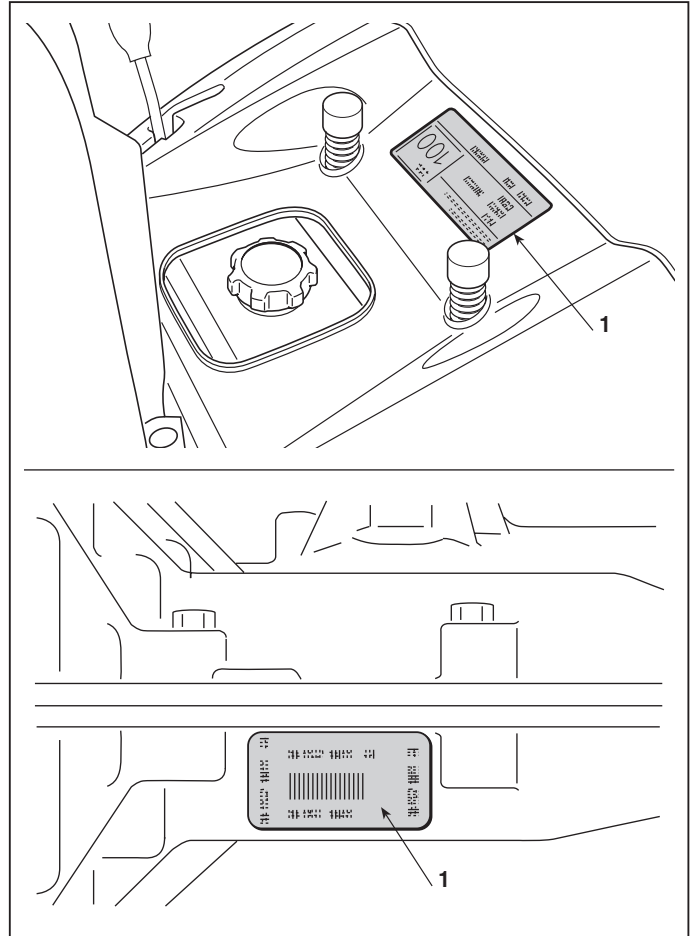

the problem, the repairs carried out and any spare parts used for each repair done on the machine.

A copy of this report must be retained to be made available to the Manufacturer together with the parts in case of any subsequent disputes with Customers.

D) Fault notification

The Manufacturer welcomes any notifications of faults that recur with particular frequency. It gives the opportunity for a careful inspection of the problem and the implementation of corrective action at production level.

Similarly, the Manufacturer will notify of any faults discovered on the machines produced, with recommendations for the most suitable procedures for their remedy.

E) Spare parts request

When requesting spare parts, the code number must be given, referring to the exploded charts for the year of manufacture, shown on the identification label [point A].

2.1 SAFETY REGULATIONS

A) Qualification of operators

All maintenance, disassembly and repairs must be carried out by expert mechanics who are familiar with all the accident prevention and safety regulations after reading through the procedures in this manual.

B) Safety measures

All the machines are manufactured in accordance with the strict European safety regulations in force. To maintain these levels of safety in the longer term, the Service Centres should work to this end by making appropriate checks every time there is the chance to do so.

Particularly, every time there is work done on the machine the Service Centre should:

1) check:

- that safety microswitches are working correctly [see 7.3];
- that the casings and protection covers have not been removed;
- that the labels with instructions or provisions have not been removed or have become illegible (these form an integral part of the safety system).

2) they should also:

- restore to proper working order any safety devices which have been manipulated or removed;
- reattach inefficient, damaged or missing casings and protection covers;
- replace illegible labels;
- not endorse any repair or modification on the machine or the engine which results in a change in performance or use that is incorrect or different from the purpose for which it was designed and approved;
- warn the Customer that the failure to comply with the above points results in the automatic annulment of the Guarantee and the Manufacturer declines all responsibility, as also shown in chapter 1 of the Instruction Booklet.

C) Precautions during servicing

The operations described in this manual do not entail particularly hazardous situations besides the

normal hazard related to mechanical operations and that can be avoided by taking the necessary care and attention normally required for this type of work.

As well as following the usual accident prevention regulations that apply to most repair shops, we recommend you:

- taking out the ignition key before beginning any repair work.
- protect hands with suitable working gloves, especially when working near the cutting unit;
- check that you do not cause accidental petrol leaks or other losses;
- do not smoke when working on the tank or when handling petrol;
- do not inhale oil or petrol fumes;
- clean up all traces of spilt petrol immediately;
- test the engine in a well-ventilated environment or where there are adequate exhaust fume extraction systems;
- do not pollute the environment with oil, petrol or other waste and dispose of all waste in accordance with the laws in force;
- ensure that other persons cannot accidentally carry out actions that may physically endanger those working on the machine.

D) Necessary equipment

All the operations can be carried out with the tools normally used in a good garage.

Some operations require special equipment and tools [➡ 2.2].

E) Symbols and terms used for safety purposes

Some paragraphs in this manual are preceded by symbols which indicate the following:



Operations that should be carried out with utmost care to avoid impairing the functionality and safety of the lawnmower.



Operations that should be carried out with utmost care to avoid injury to operators.

“WARNING” stresses the risk of injury to oneself and others if instructions and regulations are not observed

TOOLS

2.2
0

from 2007 to
page 1 / 1

2.2 TOOLS

All work can be carried out using the tools normally available from a good workshop. However, it is advisable to have a set of special tools (**1 ÷ 5**).

These tools (**1 ÷ 5**) are to be used whenever is given in this text.

1. Blocks H = 26 mm for adjusting the cutting deck
2. Blocks H = 32 mm for adjusting the cutting deck
3. Bush for assembly of blades bearings
4. Stopper for assembly of wheel bearings
5. Pulley extractor

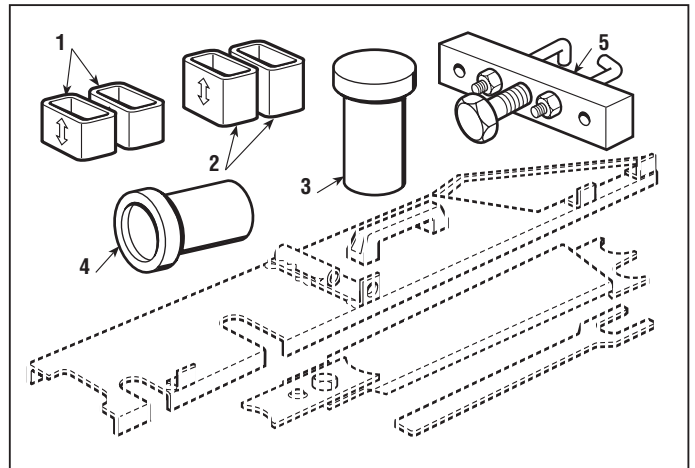

LIFTING

2.3

1

from 2007 to

page 1 / 1

2.3 LIFTING



The machine must never be lifted using a hoist or other lifting equipment which uses cables.



A) Front

ONCE THE PARKING BRAKE HAS BEEN ENGAGED, the lawn-tractor can be lifted using a jack which pushes on the underside of the frame, placing a wood block **(1)** between the base of the jack and the frame and checking to see that the free movement of the front spring equaliser has not been obstructed.

B) Rear

Place two suitable blocks **(2)** beneath the lower edge of the plate.

In any case, an appropriately sized wedge **(3)** should be placed behind the opposite wheels to stop the lawn-tractor from accidentally moving backwards.

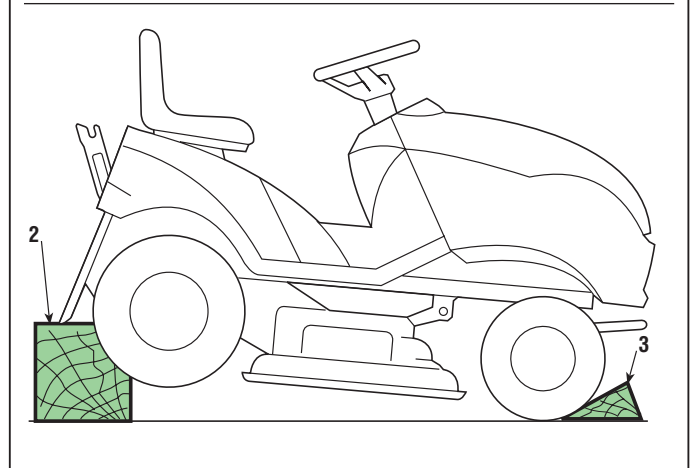
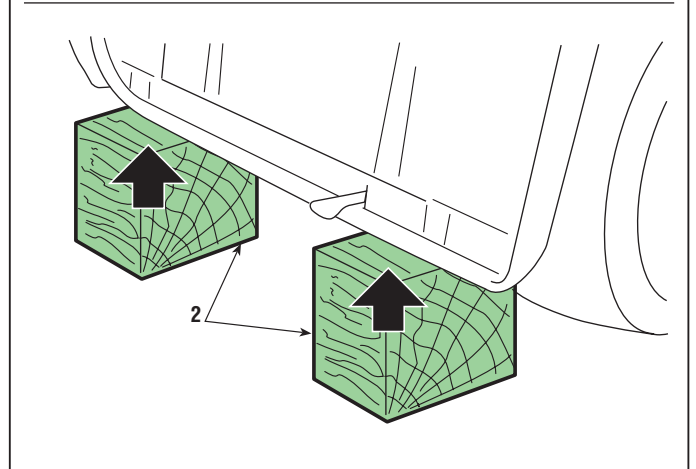
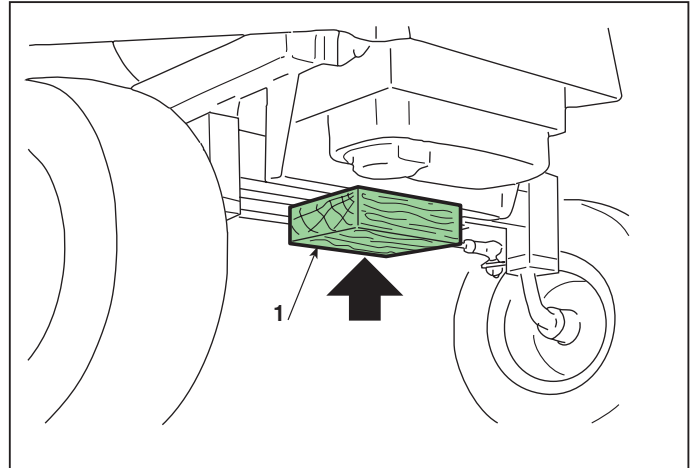

VERTICAL POSITIONING



2.4
0



from 2007 to
page 1 / 1

2.4 VERTICAL POSITIONING



WARNING! Two people will be needed for this operation. When lifting and tipping backwards, only solid parts should be gripped (steering wheel, frame, rear plate, etc.) and **NEVER** parts of the bodywork in plastic.

The tank must be checked before putting the lawn-tractor in a vertical position to make sure that there is no more than 2 litres of fuel inside.

To assure full stability, the lawn-tractor must only be rested on the points shown, inserting a block **(1)** of about 120 mm under the lower edge of the plate and taking care not to damage the parts in plastic and the grass-catcher mounts **(2)**.



WARNING! Before carrying out any type of work make sure that the machine is completely stable, and avoid operations that could cause it to fall over.



WARNING! Be just as careful when putting the machine back on a flat surface; two people are needed for this operation.

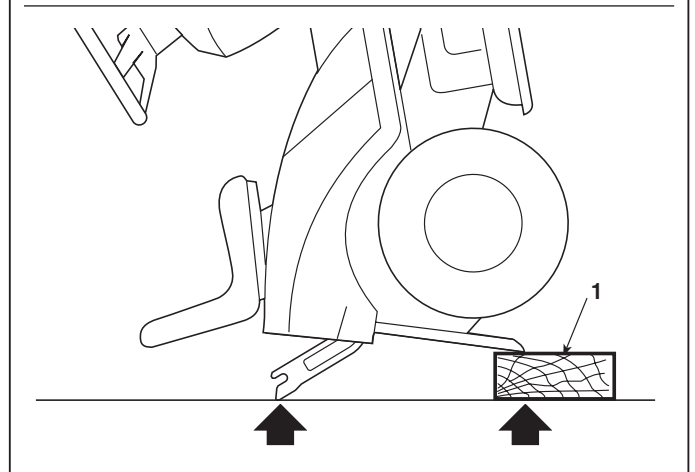
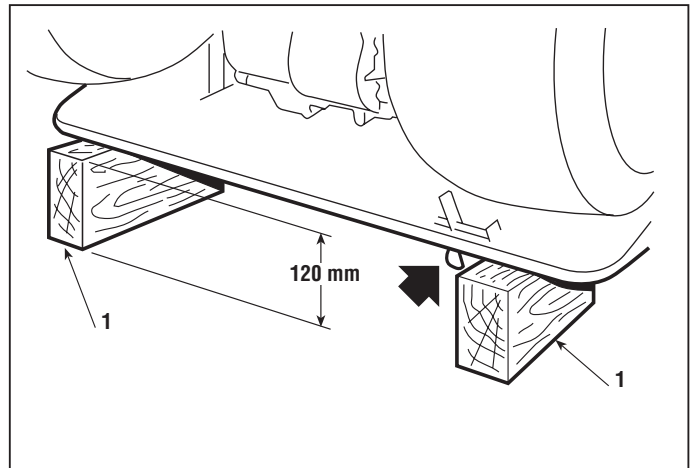

2.5 PRACTICAL HINTS

A) Fitting snap rings

One side of the “Benzing” snap rings (1) has a rounded edge and the other a sharp edge.

For maximum grip the rounded part needs to be facing towards the element to be held (2), with the sharp edges on the outside.

B) Joint pivot pins

There are a large number of pivot pins, usually connected to rods, that need to be able to move in various directions.

A typical situation has the pin (3) fixed by a self-locking nut (4) with two anti-friction washers (5) in between the pin (3) and the support element, and between this and the nut (4).

Since these are joints, the nut must never be tightened completely but only so much that it can ensure the free rotational movement of the pin on its axis without, however, creating excessive free play which could result in the parts concerned becoming misaligned and failing to work correctly.

C) Crown fasteners

Some pin ends (6) are secured by crown fasteners (7). During dismantling, these fasteners are always damaged and lose their hold, **so they should never be reused.**

On assembly, make sure it is inserted in the right direction and push the fastener (7) onto the pin using a pipe or socket spanner (8) with the right diameter, so that it can be fitted without deforming the fastener “crown”.

A deformed fastener should always be replaced.

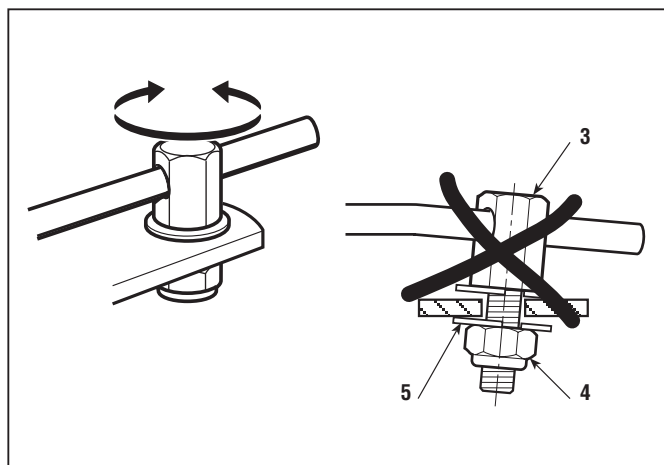
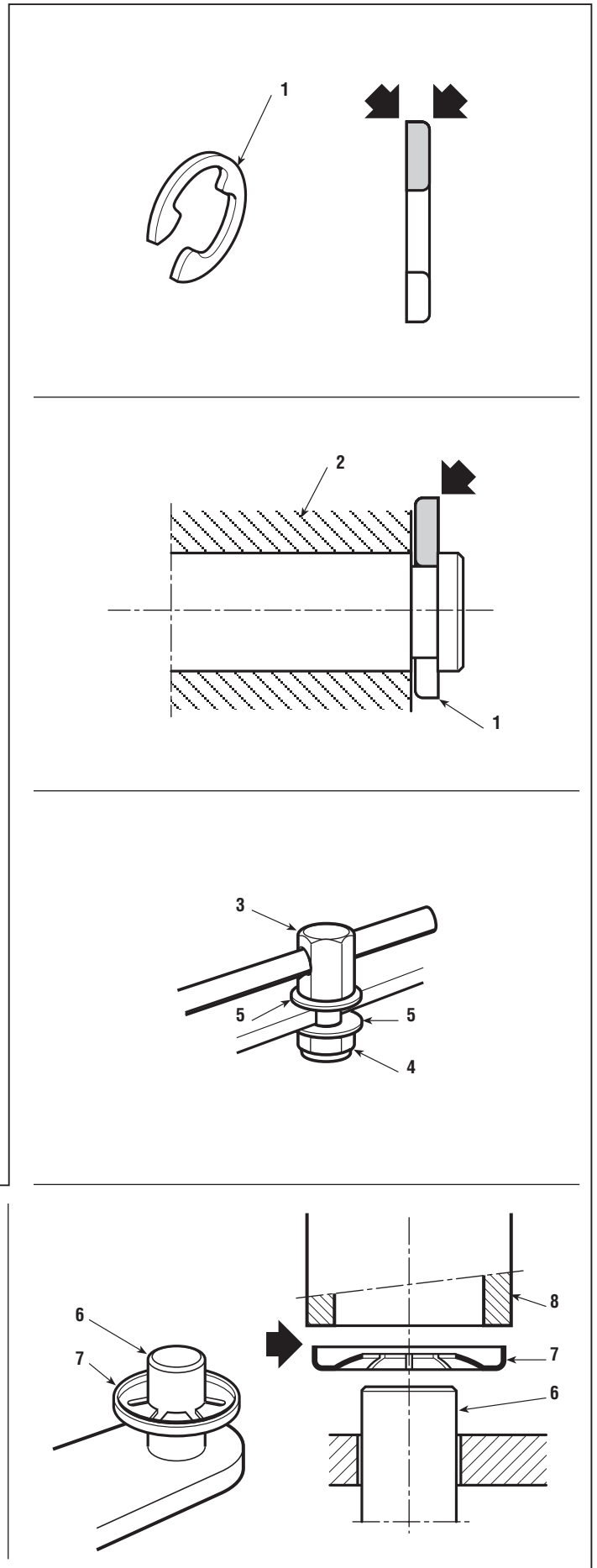

3.1 CRITERIA FOR MAINTENANCE

The Instruction Handbook has a number of operations to be carried out by the Customer for a minimum of basic maintenance, and other operations not always within his capacity.

For this reason the Service Centre should undertake to keep the machine in perfect working order in two ways:

- a) Tuning the machine whenever possible.
- b) Proposing a regular maintenance programme to the Customer to be carried out at prearranged intervals (for example, at the end of the summer or prior to a long period of inactivity).

a) Occasional tuning

- Check working order of safety devices and renew illegible or missing labels
- Check tyre pressures
- Clean air filter
- Check engine oil level
- Check for fuel leaks
- Align cutting deck
- Sharpen and balance the blades and check the condition of the hubs
- Check for wear in the belts
- Check the blade brake engagement
- Grease front wheels lever joint pins and bushes
- Check tightness of engine screws
- Check all those items indicated in the engine manual

b) Regular maintenance

- **All work carried out in section a), plus:**
- Check battery charge
- Check tension of belts
- Adjust drive engagement (► *mechanical drive models*)
- Adjust brake
- Adjust blade engagement
- Adjust blades brake
- Check steering allowance
- Check front bearings
- General lubrication
- Clean away grass cuttings and wash exterior
- Clean and wash inside cutting deck and collector channel
- Clean and wash grass-catcher
- Touching up of any damaged paint

ADJUSTING THE ENGAGEMENT AND CHECKING THE BLADE BRAKE

◀ 4.1 ▶
◀ 0 ▶

from 2007 to
page 1 / 1

4.1 ADJUSTING THE ENGAGEMENT AND CHECKING THE BLADE BRAKE

The blades are driven by the engine by means of a "V" belt and are engaged by an electromagnetic clutch.

After a certain period of use possible dimensional changes in the length of the belt could lead to operating irregularities, namely:

- belt slipping = belt elongated
- disengagement difficulties with the blades that will not stop = belt shortened.

The tension regulator must be adjusted in both cases.

Disengaging the blades causes the cutting in of a brake, incorporated in the electromagnetic clutch, whose task is to stop the blades from rotating within five seconds.

A) Adjusting blade engagement

N.B. – When adjusting the engagement it could be necessary to remove the belt guards; in this case **the guards must always be replaced after adjustment.**

With the cutting deck in its lowest position, look for the adjuster **(1)** which can be reached from the wheel arch of the right-hand rear wheel. Turn the nuts until the spring **(2)** reaches the length 97 ÷ 99 mm, measured from the outer edge of the eyelet with the blades engaged.

B) Checking the blade brake



Correct operation of the brake, which must ensure that the blades stop within 5 seconds of disengagement; **longer stopping times do not comply with the safety standards.**

If the blades do not stop within 5 seconds from disengagement, appropriate checks must be made to the electrical system [see 7.3 and 7.5] and the clutch must be replaced if no result is achieved.

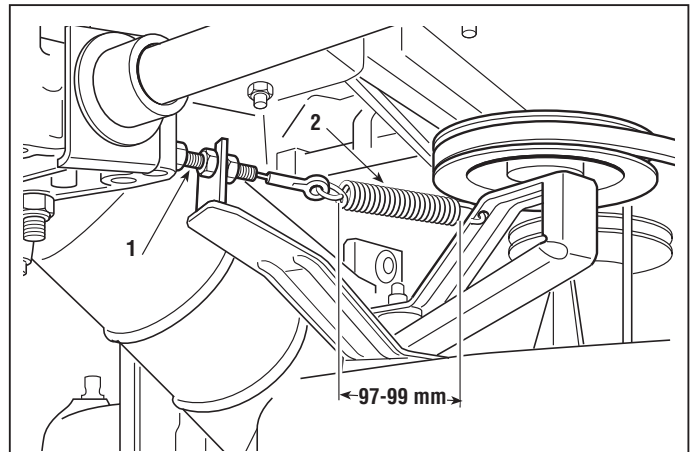

BRAKE ADJUSTMENT



4.2
0



from 2007 to
page 1 / 2

4.2 BRAKE ADJUSTMENT

Reduced braking power is corrected by adjusting the spring on the brake rod.

The brake adjustment spring can be accessed by removing the inspection hatch (1).

The adjustment is to be made with the parking brake engaged and consists of altering the length of the spring (2) to the best measurement. The braking capacity is increased by screwing the nut down on the rod (and thus shortening the length of the spring).

Loosen the nut (4) which retains the bracket (5) and then turn the nut (6) so that the length «A» of the spring (2) is:

- 43,5 ÷ 45,5 mm ► *In mechanical drive models*
- 45 ÷ 47 mm ► *In hydrostatic drive models*

measured from the inside of the washers. When the adjustment has been made, tighten the nut (4).

Never go under these amounts to avoid overloading the brake unit.



When the adjustments have been made, the parking brake should prevent the lawn-tractor from moving on a slope of 30% (16°) with the driver in position.

► ***In mechanical drive models:***



If braking is still poor or uneven even after having made the adjustment, remove the control rod (3) from the lever (7) and check that this lever has a free movement of 20 mm (measured vertically next to the pin rod) before beginning the braking action. If this is not the case, the free movement can be adjusted with the screw (8), unless the brake pads or discs are so worn that they need replacing [see 6.9].

When connecting the rod (3) be sure to use the uppermost hole in the lever (7) and then check the length of the spring again (2).

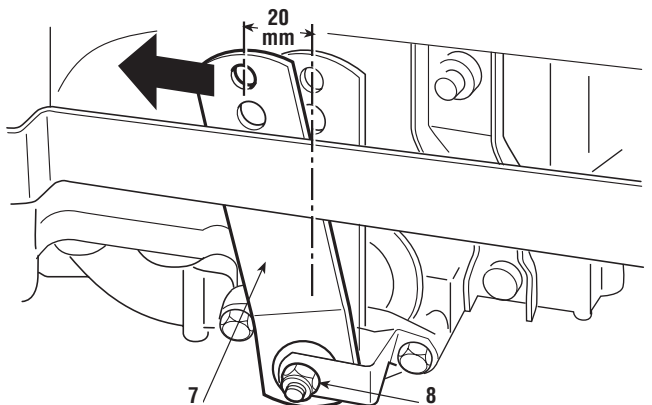
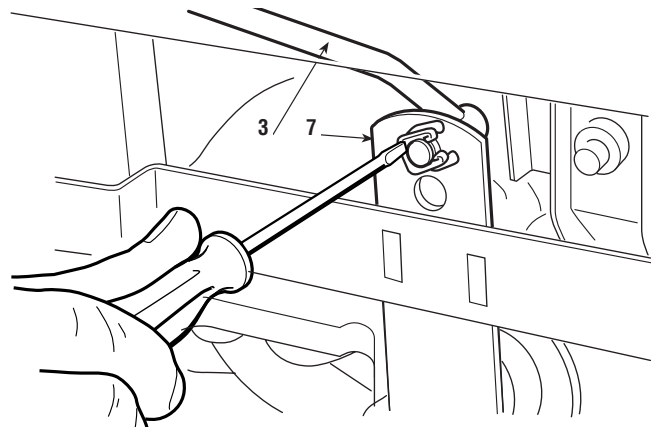
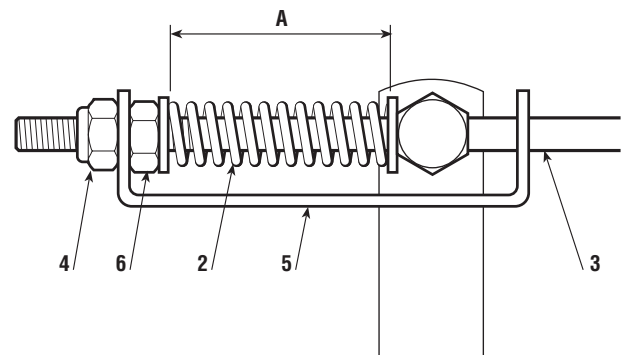
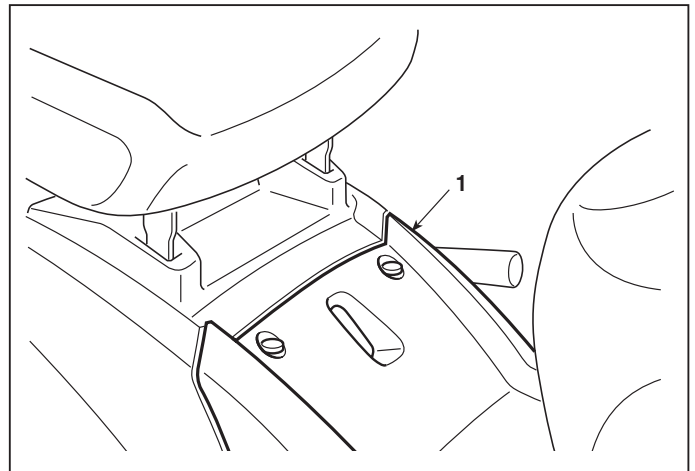

BRAKE ADJUSTMENT

4.2
0

from 2007 to

page ◀ 2 / 2

► ***In the hydrostatic drive models:***

If braking is still poor or unsteady even after making the adjustment, you cannot make any further adjustments from the outside. Therefore you need to dismantle the whole rear axle of the machine [see 5.6] and contact one of the manufacturer's Service Centres.

DRIVE BELT ADJUSTMENT

4.3
0

from 2007 to
page 1 / 1

4.3 DRIVE BELT ADJUSTMENT

If it seems that the forward drive is not working properly after a long period of use or after replacing the belt, this may be caused by a change in the length of the belt.

- A loose belt reduces output from the transmission and limits forward movement power;
- a belt which is too tight increases noise and results in jerky movements or tipping up when engaging the drive.

In these cases the stretcher will need to be adjusted.

The tension regulator can be accessed by removing the inspection hatch.

Adjust the tension of the spring **(1)** by suitable working on the nuts **(2)** until a measure of 119 ÷ 121 mm is obtained, measured on the outside of the turns, with the transmission controls in neutral.

Lock the nuts **(2)** when the adjustment has been made.

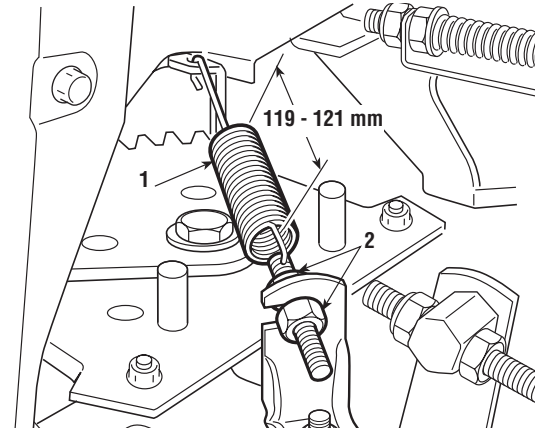

DRIVE PEDAL ADJUSTMENT

4.4

0

from 2007 to

page 1 / 1

4.4 DRIVE PEDAL ADJUSTMENT (► Hydrostatic drive models)

This operation should be carried out every time the rear axle, the pedal or the control rod is removed in order to get the correct travel for the pedal and to enable reaching the envisaged speeds both forwards and in reverse.

A) Adjusting the pedal in the “neutral” position

The pedal position is to be adjusted starting with the lever (1) of the hydrostatic unit in the “neutral” position. This position «N» is easily recognised, since it is held fast by a check ball.

The pedal (2) is in its best position when, with the hydrostatic group lever (1) in “neutral”, the lower edge of the front inclined section of the pedal itself is at 85 mm from the metal edge of the footboard (3).

This is obtained by opening the inspection hatch beneath the seat and by turning the nuts (4) appropriately until the required measurement is reached. Take care not to accidentally modify the position of the lever (1) during the adjustment.

B) Adjusting the “neutral” position of the micro-switch



IMPORTANT!

This is a very important adjustment for the correct operation of the safety devices for starting and stopping of the machine during work.

The “neutral” position «N» is indicated by the microswitch (5) of the cam (6), which is reached by the inspection hatch beneath the seat.

After having ensured that adjustment “A” has been made correctly, with the pedal released and thus in neutral position «N», slacken off the microswitch fixing screws (7) and position it in line with the tip of the cam, so that it remains pressed [see 7.10].

By moving the pedal in the forward, neutral and reverse positions, make sure that the push-button clicks at every position change before the wheels start moving.

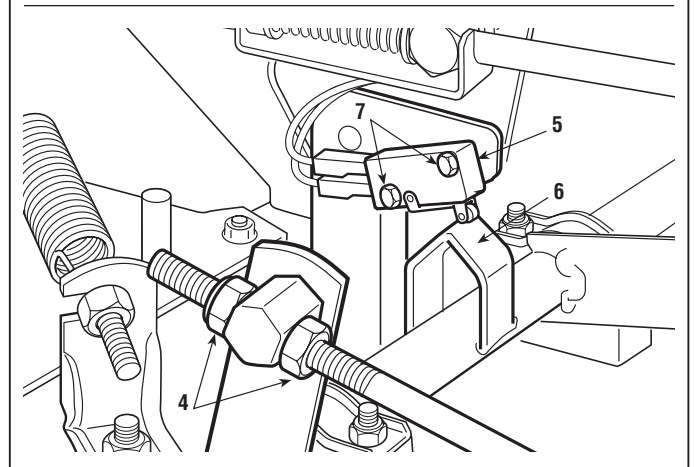
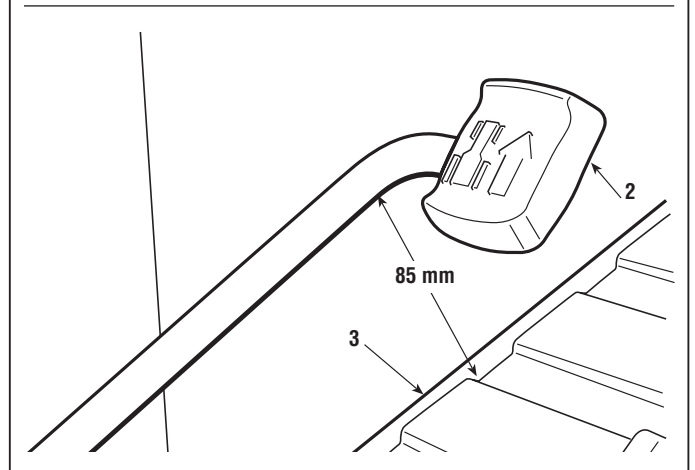
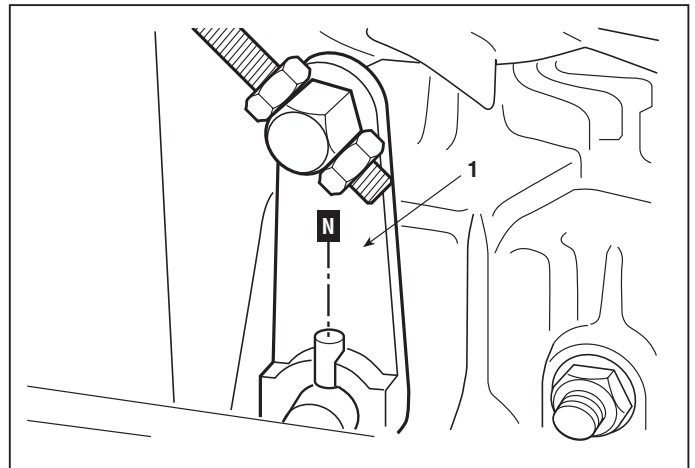

ALIGNING THE CUTTING DECK

4.5

0

from 2007 to

page 1 / 2

4.5 ALIGNING THE CUTTING DECK

Lowering of the cutting deck is controlled by a linkage operated by the lever and is guided by two front articulation connecting rods.

In order to get a good cut it is essential that the cutting deck is parallel with the ground crosswise, and slightly lower at the front.

- a) a combined adjustment to the parallel and the minimum height front and back
- b) adjusting the regularity of raising and lowering

Check the tyre pressures. If one or more tyres have been replaced or you find differences in diameter, **do not attempt to compensate these differences by giving different tyre pressures**, but make the adjustments as in point "A".

N.B. – When aligning the cutting plate it could be necessary to remove the belt guards; in this case **the guards must always be replaced after adjustment**.

A) The combined adjustment to the parallel and the minimum height front and back

Put the lawn-tractor onto a flat and stable surface (such as a work bench) and put blocks beneath the cutting deck in line with the centre lines of the blades:

- at the front 26 mm (1)
- at the rear 32 mm (2)

Put the height lever in position «1».

Unscrew the nuts (3 - 5 - 7) and locknuts (4 - 6 - 8) so that the deck rests on the blocks.

Turn the nuts (9) (first remove the central covering) so that the rear left connecting rod (10) starts moving at the slightest movement of the lifting lever, and then secure it in place.

Screw down the rear left nut (3) until the rear edge of the cutting deck begins to rise,

Screw down the front nuts (5 - 7) until the front edge of the cutting deck begins to rise evenly, both on the right and left side.

Screw down the three locknuts (4 - 6 - 8).

Check that the deck rises and lowers regularly as indicated in point "B".

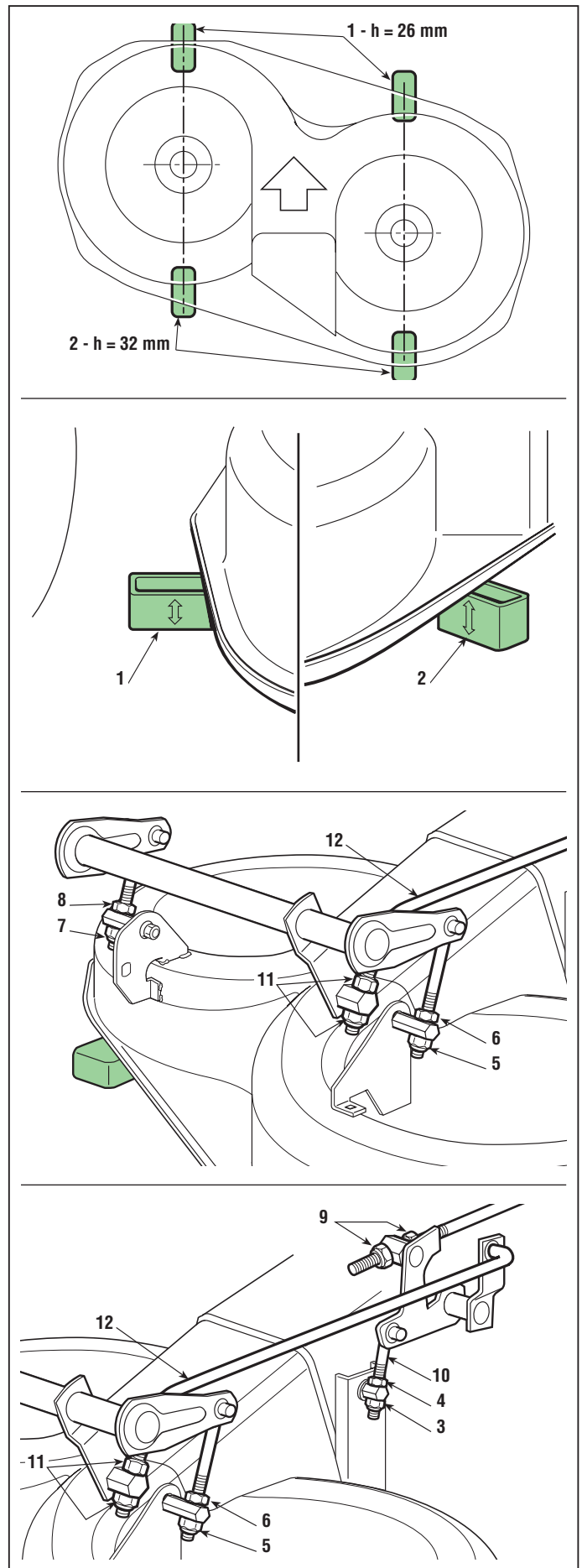

ALIGNING THE CUTTING DECK



4.5
0



from 2007 to

page ◀ 2 / 2

B) Adjusting the regularity of rising and lowering

When the adjustment as at point “A” has been made, put the control lever in 2 or 3 different positions and check that the deck rises evenly and that at each position it constantly maintains the difference in height from the ground between the front and back edges.

If the front edge tends to rise before or after the back edge, turn the nuts **(11)** on the connecting rod **(12)**; tighten the nuts, the front edge will rise first, while if you loosen them, the back edge rises first.

When you have finished the adjustment, always check that all the nuts and locknuts are tightened securely.

ADJUSTING THE STEERING PLAY

4.6

0

from 2007 to

page 1 / 1

4.6 ADJUSTING THE STEERING PLAY

Steering play must never be excessive in order not to effect driving precision.

Check that the steering play is not caused by the slackening off of the tie-rod system and fully tighten all the tie-rod and ball joint nuts.

If the play is due to the crown wheel/pinion pairing, the position of the spacer, fitted to lift the crown wheel and reduce the gap between the teeth, must be changed.

To make the adjustment, remove the inspection hatch, slacken off the register (1) and unhook the spring (2) of the traction guide pulley.

Working from the bottom of the machine, unscrew the nut (3), being careful to adequately support the crown wheel axle components to prevent them from unthreading themselves completely.

Remove the screw (4) below which the spacer (5) is located.

Remove the crown wheel (6) and fit the spacer (5) under it so as to place it in a higher position with respect to the pinion (7), reducing the gap between the teeth.



Refit the crown wheel (6), matching up reference (→), punched in the centre, with reference (I) of the pinion

Refit screw (4) and nut (3), tightening it to the pre-scribed value.

Replace the traction guide pulley spring (2) and ...

➡ Adjust the traction engagement [see 4.3].

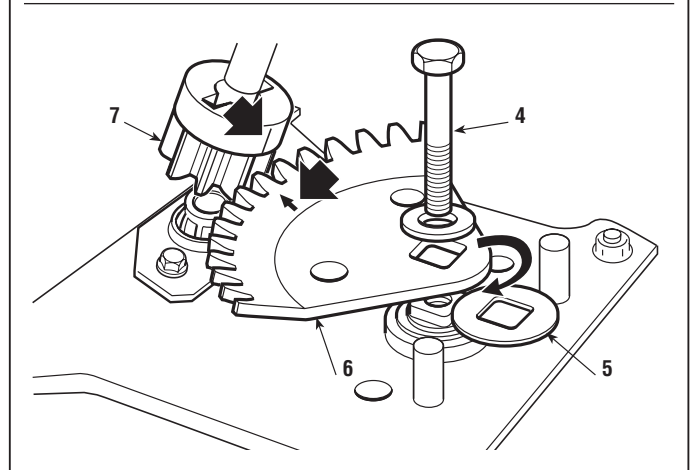
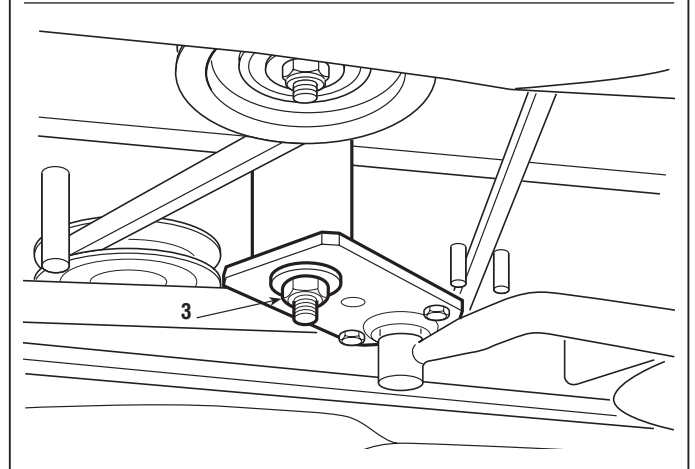
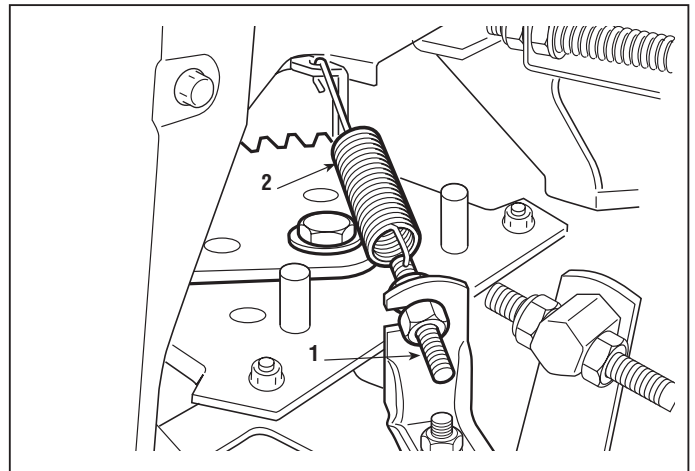

Tightening torque

3 Nut for ring gear 45 ÷ 50 Nm

STEERING GEOMETRY ADJUSTMENT

4.7
0

from 2007 to
page 1 / 1

4.7 STEERING GEOMETRY ADJUSTMENT

The correct steering geometry is given by the values of the intercentre distance between the joints of the tension rod and the wheel connecting rod. Any faults caused by knocks or accidents result in reduced driving precision and increased wear on the tyres. These can be overcome as follows:

- uneven or excessive wear on the front tyres = toe-in adjustment
- the lawn-tractor does not maintain a straight line when the steering wheel is straight = adjustment of tie-rods.

NOTE

Before any other action, check that the joint fastenings have not become loose.

A) Toe-in adjustment

The exact toe-in is obtained with a track of 483-485 mm, measured between the centres of the pins (1) of the wheel connection rod (2).

If a different value is detected, suitably adjust the nuts and locknuts (3 - 4), from one or both sides, screwing them in or out on the rod by the amount needed.

Having made the adjustment check that the nuts and locknuts (3 - 4) are fully tightened.

B) Adjustment of the steering wheel

First check the toe-in (point "A") and align the front wheels.

If the steering wheel is not straight, suitably adjust the nuts and locknuts (5 - 6), screwing them in or out on the rod (7) by the amount needed.

Having made the adjustment check that the nuts and locknuts (5 - 6) are fully tightened.

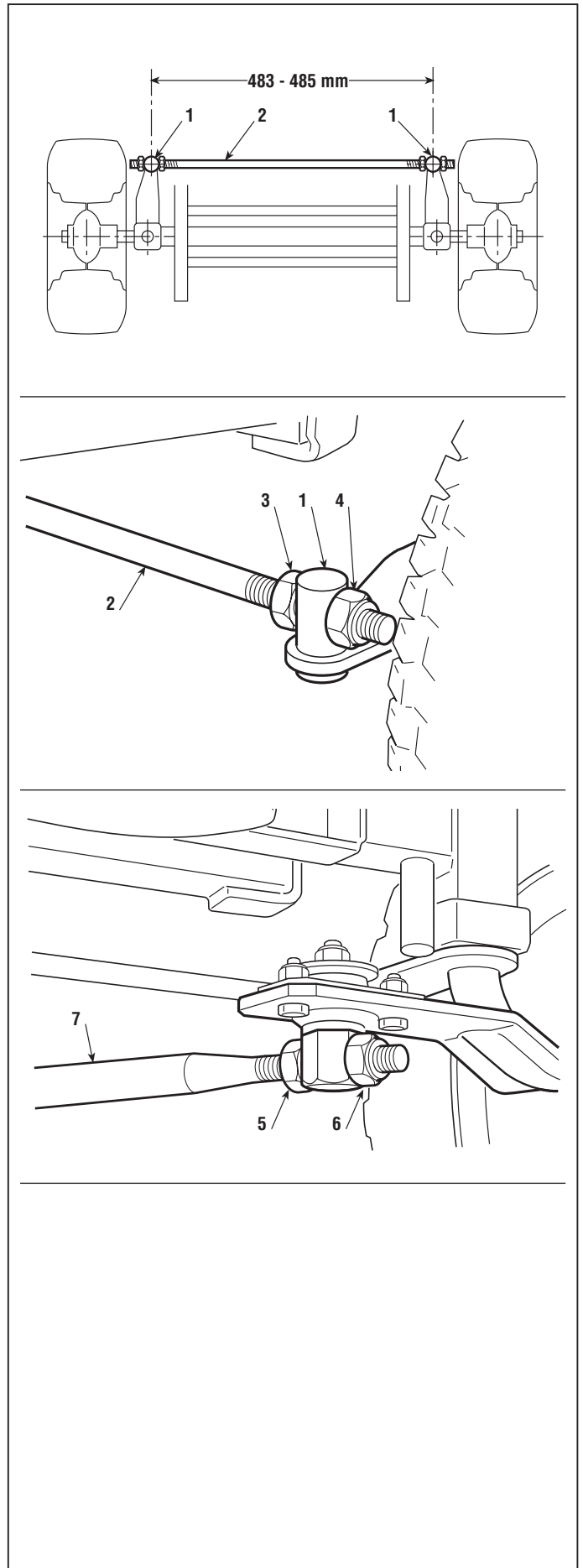

Tightening torques

3 - 4 - 5 - 6 Nuts and Locknuts 18 ÷ 20 Nm

CHECKING BLADES ALIGNMENT

4.8
0

from 2007 to
page 1 / 1

4.8 CHECKING BLADES ALIGNMENT

Excessive vibration when cutting and an uneven cut can be due to misalignment of the blades owing to deformation of the flanges or the shafts as a result of accidental knocks.

- ➡ Put the lawn-tractor into a vertical position [see 2.4].



Always wear strong gloves when handling the blades.

With the blades disengaged, firmly hold each blade and bring the cutting edges together in the various positions possible (A-B; A-B1; A1-B1; A1-B). At each position they should be aligned to within 2 mm.

If higher amounts are found, check that the blades are not distorted. If this is not the case, check the supports or the shafts for the blades [see 6.9], replacing if necessary, and check the condition of the point where the flange rests on the cutting deck.



IMPORTANT!

Always replace damaged blades and do not attempt to repair or straighten them. Always use manufacturer's genuine spare parts!

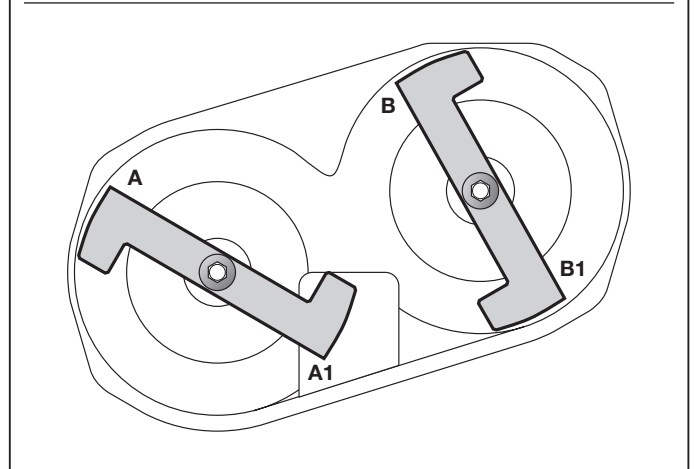
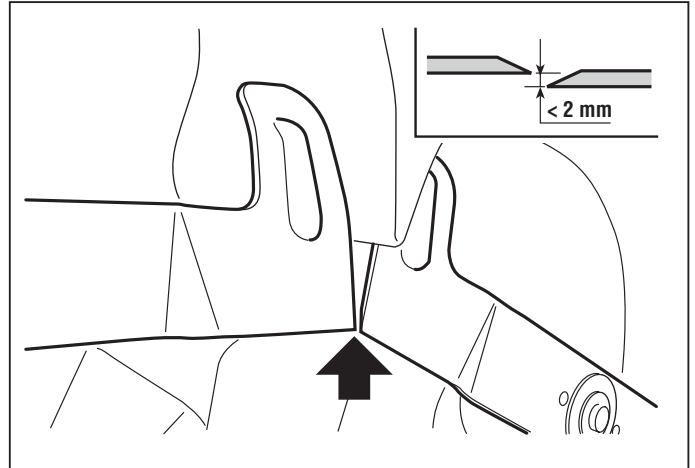

REMOVING, SHARPENING AND BALANCING THE BLADES

4.9
0

from 2007 to
page 1 / 1

4.9 REMOVING, SHARPENING AND BALANCING THE BLADES

A badly sharpened blade causes grass to become yellow and reduces grass collection capability. If not balanced, excessive vibration can be caused during use.



Always wear protective gloves when handling the blades and protect eyes when sharpening.

A) Removing and reassembling

For removing a blade it must be firmly held and the central screw **(1)** undone, bearing in mind that:

- the screw on the left blade **(1a)** is unscrewed anti-clockwise
- the screw on the right blade **(1b)** is unscrewed clockwise.



On assembly, be careful to:

- correctly position the keys **(3)** on the shafts;
- correctly locate the right and left blades, with the fins facing towards the inside of the plate;
- fit the flexible disc **(4)** so that the concave part is pressing against the knife;
- tighten the screws **(1 - 1a)** with a torque wrench set to 45-50 Nm.

B) Sharpening and balancing

Always sharpen both cutting edges of the blade **(2)** using a medium grade grinder. Sharpening must only be done from the rounded side, removing as little as possible.

The blade is to be replaced when the cutting edge has worn down to 10 mm.

Using the appropriate equipment, check the balance to make sure that there is a maximum difference of 2 grams between one side and the other.

Tightening torques

1a	Screw for left blade	45 ÷ 50 Nm
1b	Screw for right blade	45 ÷ 50 Nm

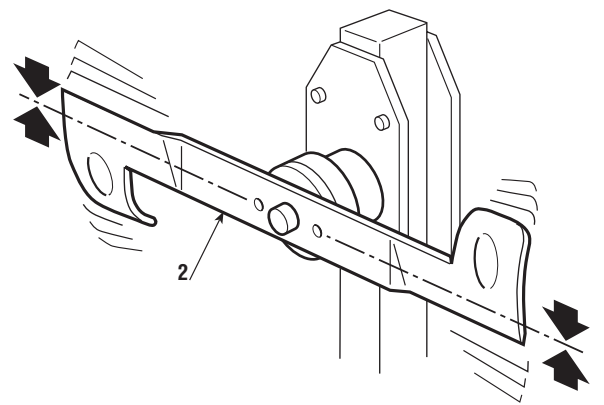
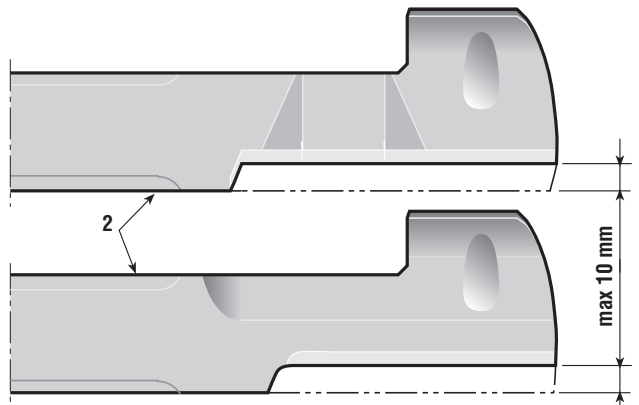
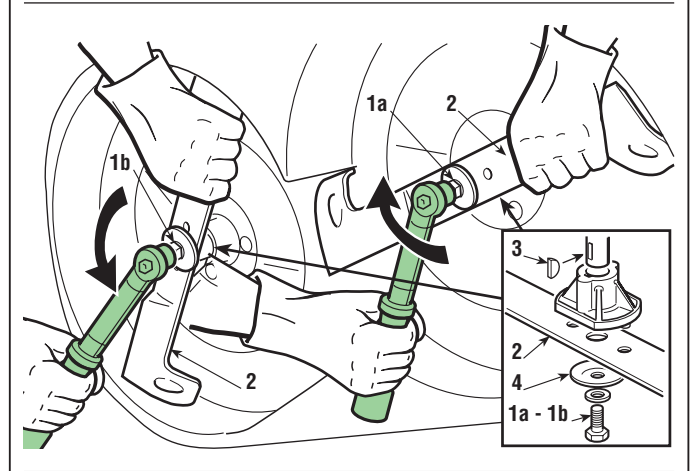
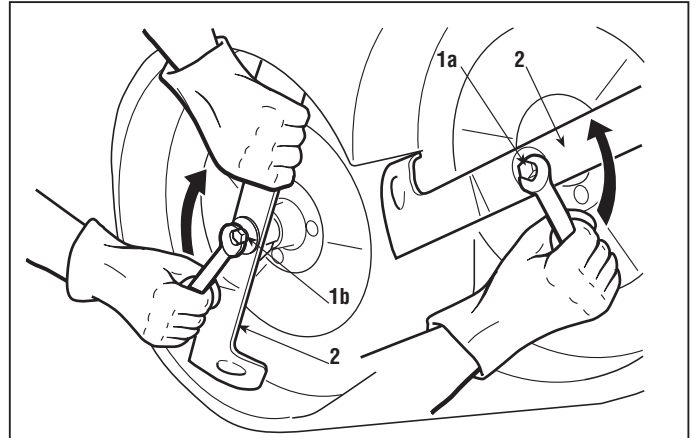

REMOVAL OF FRONT HOOD

5.1
0

from 2007 to
page 1 / 1

5.1 REMOVAL OF FRONT HOOD

The removal of the front hood gives greater accessibility to:

- the engine and its accessories
- the silencer and protection devices

► **In models with lights:**

Disconnect the connector (1).

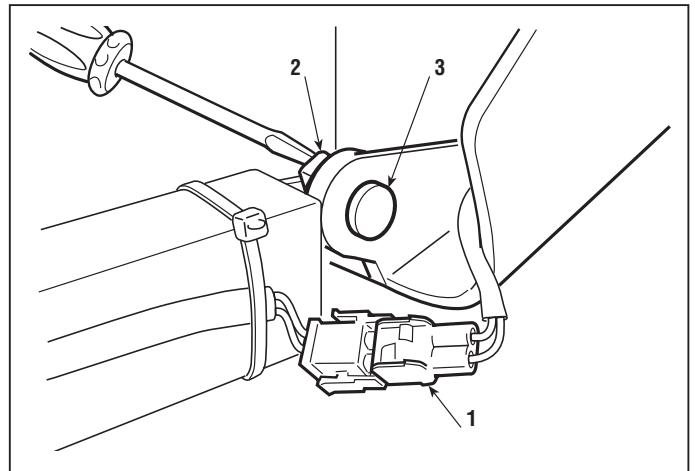

The hood can be secured in two ways.

A) Fixing with springs

Unhook the two fastener springs (2) and pull out the pins (3).

B) Fixing with a split pin

Take out the split pin (4) from the right-hand side and remove the hood by moving it to the right.

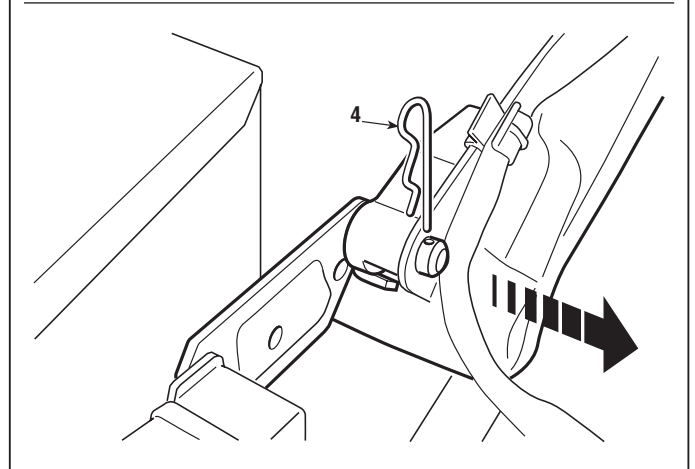

REMOVAL OF THE WHEEL COVER

5.2

1

from 2007 to

page 1 / 2

5.2 REMOVAL OF THE WHEEL COVER

Removal of the wheel cover, apart from its replacement or particular operations, is only necessary for accessing the fuel tank (Rear type).

Remove the inspection hatch (1).

Remove the spring covering plugs (2) and dismantle the two pins (3) to remove the seat.

Unscrew the screw (4) and remove the bag present signal microswitch guard (5).

► In models with mechanical transmission: unscrew the gear lever knob (6).

The cover (7) is fixed by:

- 2 lower screws (8) (1 for each side) located under
- 6 rear screws (9) (3 for each side), for fixing on the rear plate.

The cover can be removed after the cutting height adjustment lever has been set to position "7".

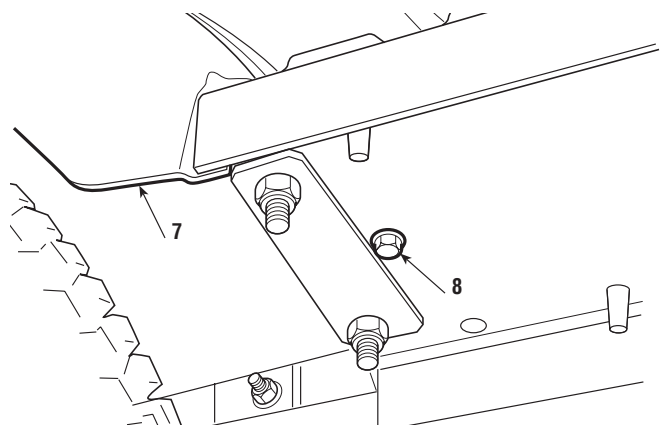
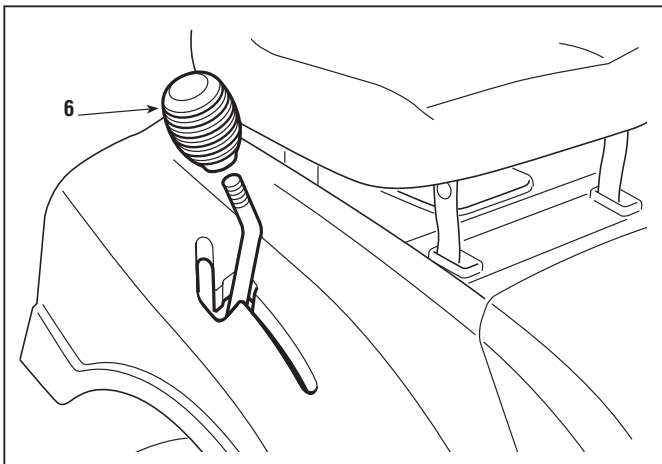
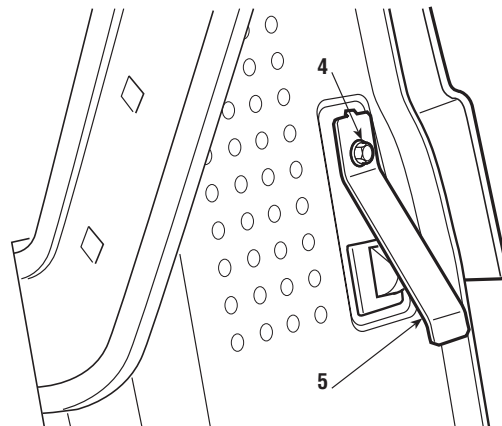
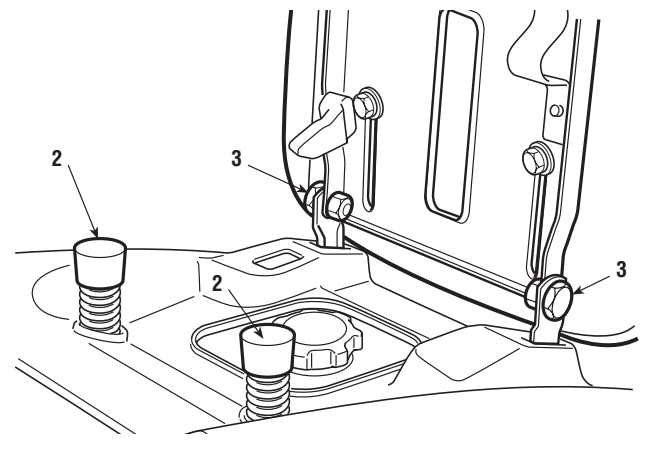
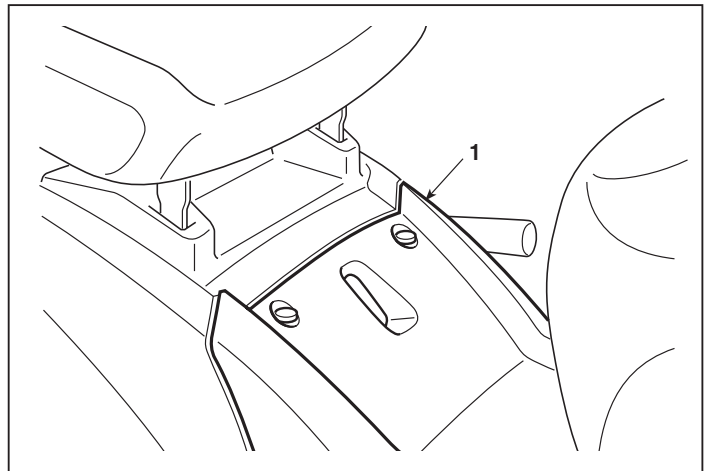

REMOVAL OF THE WHEEL COVER



5.2
0



from 2007 to

page 2 / 2

For reassembly, follow the procedure described above in reverse, being careful to correctly insert the two side tongues (10) of the cover in the housings in the footboards.



IMPORTANT! – Check the correct assembly of the bag present microswitch guard (5), so as to ensure regular operation of the safety systems.

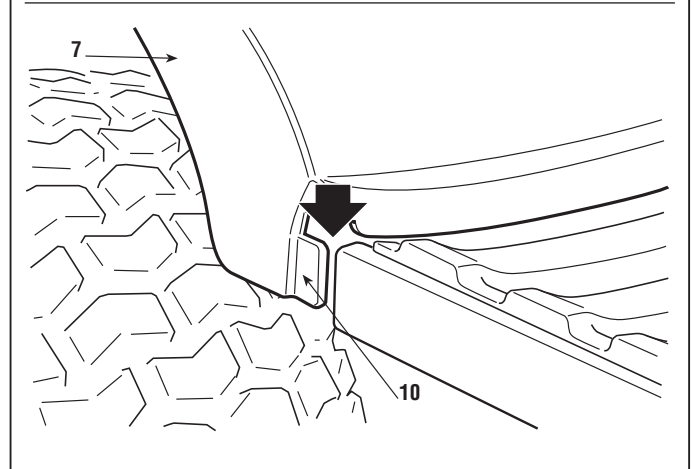
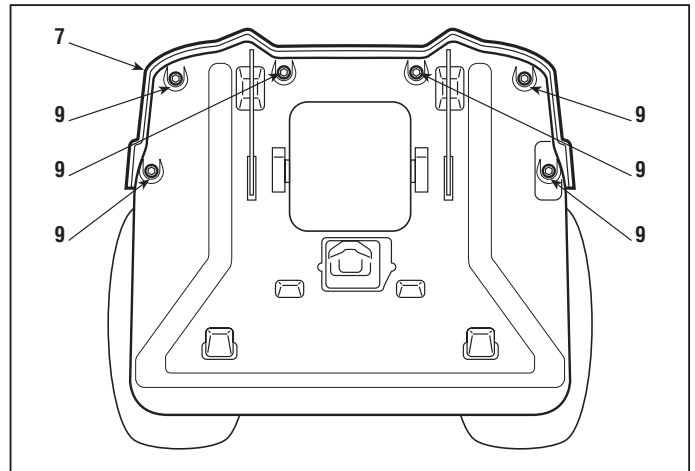

REMOVING THE EJECTION CONVEYOR

5.3
0

from 2007 to
page 1 / 1

5.3 REMOVING THE EJECTION CONVEYOR

Removing the conveyor gives access to:

- *the small side wheels and the transmission belt,*
- *the joints of the cutting plate lifting lever.*

The conveyor **(1)** is connected to the rear plate **(2)** by two plastic clamps **(3)**, removable with the help of a screwdriver.

On assembly, ensure the free vibration of the conveyor at each plate height variation.

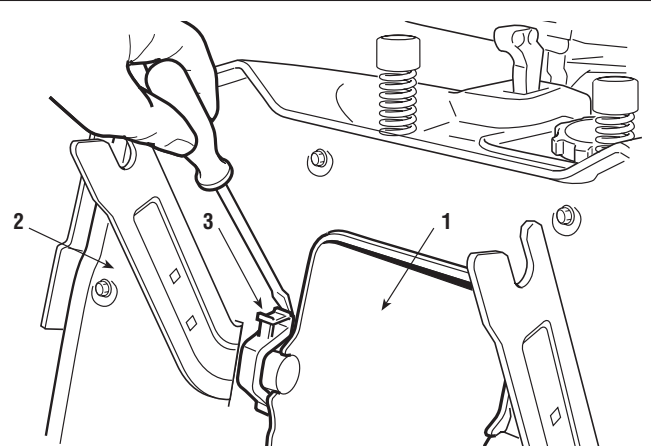

REMOVING THE TANK AND REPLACING THE FUEL PIPE

5.4
0

from 2007 to
page 1 / 1

5.4 REMOVING THE TANK AND REPLACING THE FUEL PIPE

Removing the tank is only necessary for its replacement; part of this procedure must be followed in the case of fuel pipe replacement.

➡ Remove the wheel cover [see 5.2].

Disconnect the fuel pipe (1) from the two cable clamps (2), accessible from the inspection hatch.



Remove the clip (3), unthread the pipe (1) from the fuel filter entry (4) and empty the tank completely, **suitably saving all the petrol it contains and being careful not to leak it in the work area.**

Remove the clip (5) and unthread the pipe (1) from the tank outlet union (6).

Take out the plug (7) and remove the cup (8).

Unscrew the four nuts (9) and remove the rear seat support (10).

Unscrew the two fixing nuts (11) and remove the tank (6).



For reassembly follow the operations described above in reverse, being careful to:

- always replace the fuel pipe;
- remember to reposition the fixing clips and to fix the pipe to the cable clamps;
- **check that there are no fuel leaks.**

N.B. - The fuel pipe is supplied in sections of 1 metre, which must be cut to the specific length required by the various types of engine, according to the following table:

Engine	Pipe length (mm)
B&S 13 - 15 HP	650
TECUMSEH 13 HP	650
HONDA GVC 520	650
KOHLER 16 - 18 HP	750

➡ Replace the wheel cover [see 5.2].

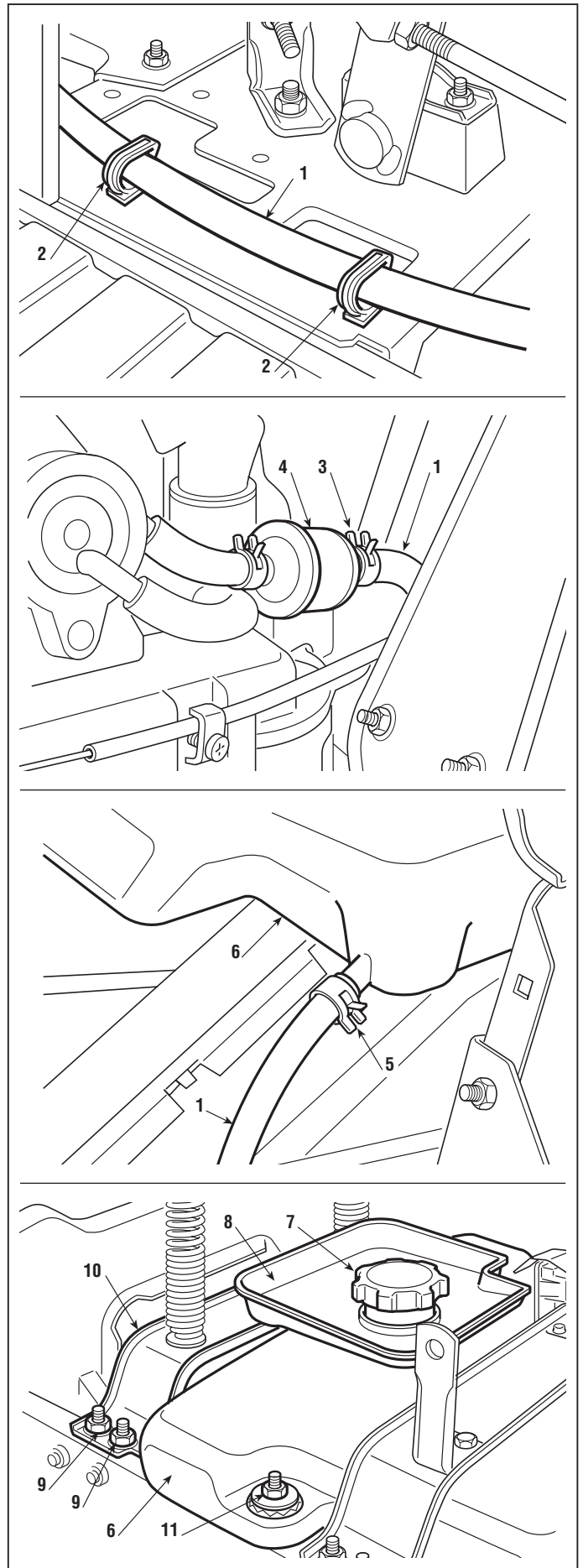

REMOVING THE TANK (Front type) AND REPLACING THE FUEL PIPE

◀ 5.4a ▶
◀ 0 ▶

from 2008 to
page 1 / 1

5.4a REMOVING THE TANK (Front type) AND REPLACING THE FUEL PIPE

Removing the tank is only necessary for its replacement; part of this procedure must be followed in the case of fuel pipe replacement.



Remove the clip (1), unthread the pipe (2) from the fuel filter entry (4) and empty the tank completely, **suitably saving all the petrol it contains and being careful not to leak it in the work area.**

Remove the clip (4) and unthread the pipe (2) from the tank outlet union (5).

Loosen the fixing screw (6) and remove the tank (5).



For reassembly follow the operations described above in reverse, being careful to:

- always replace the fuel pipe;
- remember to reposition the fixing clips and to fix the pipe to the cable clamps;
- **check that there are no fuel leaks.**

N.B. – The fuel pipe is supplied in sections of 1 metre, which must be cut to the specific length required by the various types of engine, according to the following table:

Engine	Pipe length (mm)
B&S 13 - 15 HP	200
TECUMSEH 13 HP	200
HONDA GVC 520	200
KOHLER 16 - 18 HP	200

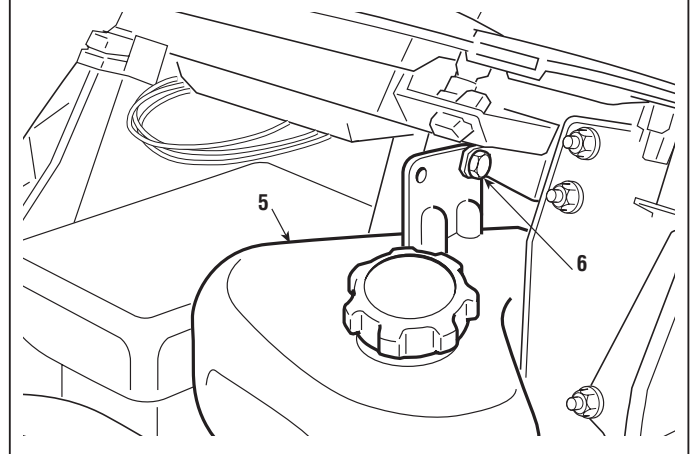
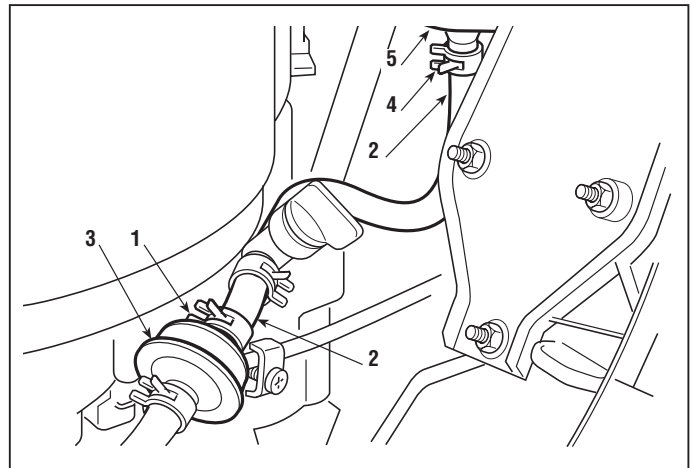

REMOVAL OF THE ENGINE



5.5
0



from 2007 to

page 1 / 2

5.5 REMOVAL OF THE ENGINE

Since there are different types of drive, the stages described here refer to those shared or similar in all types of engine.

➡ Remove the front hood [see 5.1].

For greater operating convenience it is recommended that the transmission belt is slackened off; this is done by ...

➤ **In mechanical transmission models:** engaging the parking brake.

➤ **In hydrostatic transmission models:** slackening off the tension regulator [see 4.3].



FIRST disconnect the black earth cable from the battery, and THEN the red cable, to prevent possible short circuits and dangerous situations.

Free the blade belt (1) from the clutch pulley (2).

Disconnect the connectors (3) from the clutch contacts (2), unhook the return spring (4) from the clutch side and unscrew the central screw (5) with the help of a power screwdriver.

Remove the clutch (2) from the shaft, together with the transmission command pulley (6) and the spacer (7).

Remove the exhaust guard (8) and disconnect the accelerator cable control and all the electric cables.



Remove the clip (9), unthread the pipe (10) from the fuel filter entry (11) and empty the tank completely, suitably saving all the petrol it contains and being careful not to leak it in the work area.

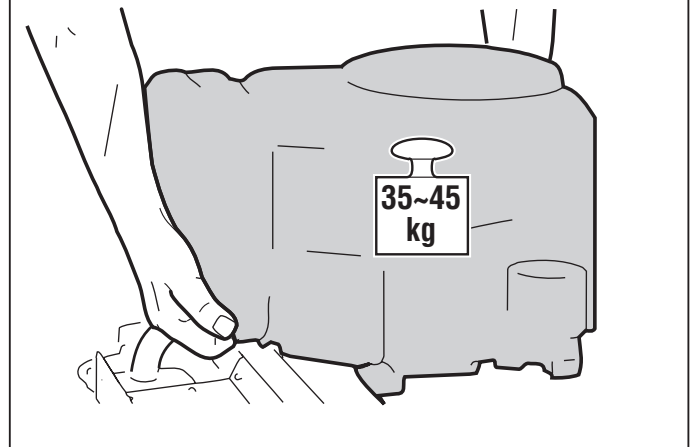
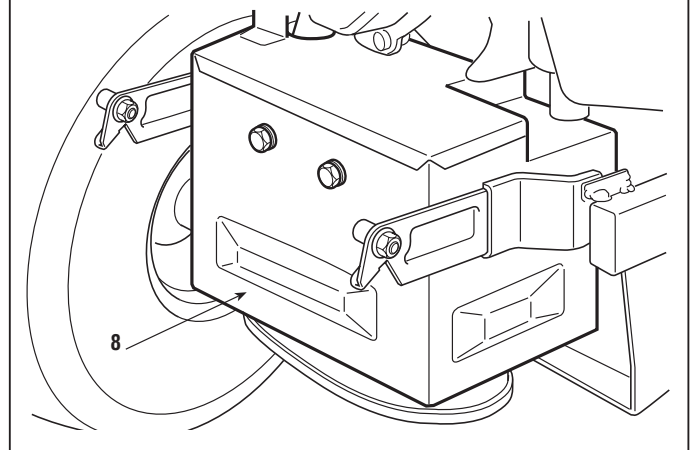
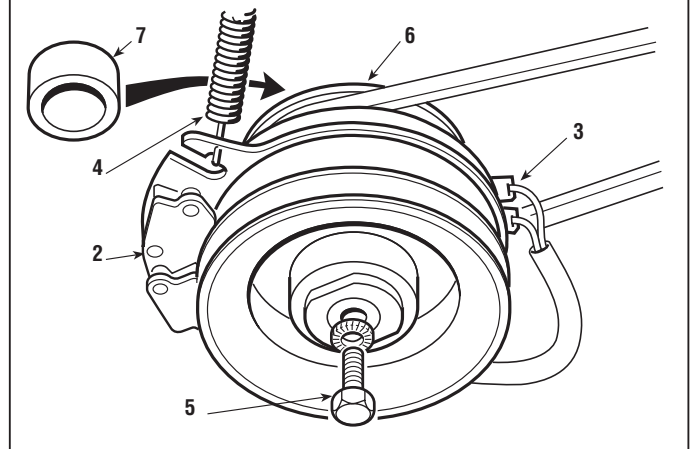
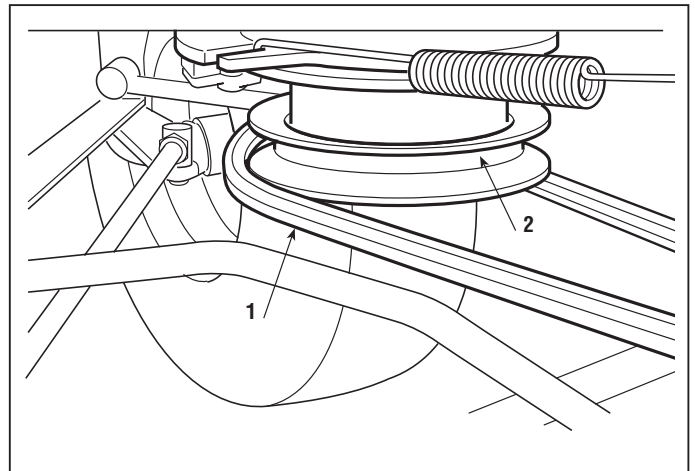

REMOVAL OF THE ENGINE

◀ 5.5 ▶
0 ▶

from 2007 to
page ◀ 2 / 2

Having identified the screws fixing the engine to the chassis, grasp the former firmly and lift it with due care, remembering that it weighs about 35-45 kg.

N.B.

Some types of engine can be fixed with screws of a different length and in a different position, so it is advisable to mark them, to prevent errors on reassembly.

For reassembly follow the operations described above in reverse.

Ensure that the pin (12) is inserted in the groove in the clutch (2) and remember to replace the spring (4).

Fully tighten the engine and pulley fixing screws to the prescribed values.



Remember to replace the fuel pipe fastening clamps and **check that there are no leaks**. Carefully restore all electric and earth contacts and always refit the exhaust guard (8).

Refit the accelerator cable and...

- ➡ Adjust the "TICK-OVER" position [see 6.8].
- ➡ Refit the front bonnet [see 5.1].

➤ **In hydrostatic transmission models:** restore the tension in the tension regulator spring if it has slackened off [see 4.3].

Tightening torques

5 Screw for pulley	45 ÷ 50 Nm
- Screws for engine fastening	25 ÷ 30 Nm

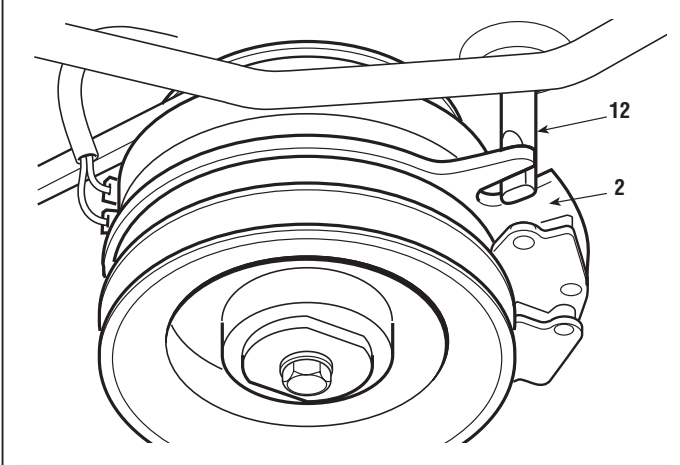
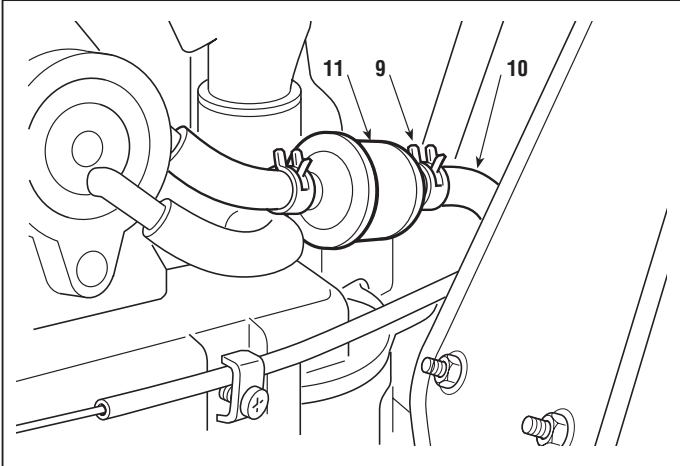

REMOVAL OF THE REAR AXLE

5.6

1

from 2007 to

page 1 / 3

5.6 REMOVAL OF THE REAR AXLE

The rear axle (Transaxle) is made up of single maintenance free sealed unit which includes the transmission unit (➤ mechanical or ➤ hydrostatic) and the differential.

It only needs to be removed to be replaced or for an overhaul by the Manufacturer's Service Centre.

➤ Remove the collector channel [see 5.3].

Place two spacers **(1)** of approximately 160 mm under the rear plate.

➤ Remove the rear wheels [see 6.1].

For greater operating convenience it is recommended that the transmission belt is slackened off; this is done by ...

➤ **In mechanical transmission models:** engaging the parking brake.

➤ **In hydrostatic transmission models:** grasping the two branches of the belt **(2)**, pulling it just enough to free it from the pulley throat **(3)**, overcoming the resistance of the tension regulator guide pulley.

The dismantling procedure has slight differences according to the various types of transmission used.

➤ **In mechanical transmission models:**

Dismantle the belt guide **(4)** from the rear plate and disconnect the gear control shaft **(5)** slackening off the brake control screw **(6)** and rod **(7)**.

Disconnect the "neutral" signal microswitch **(8)** cables.

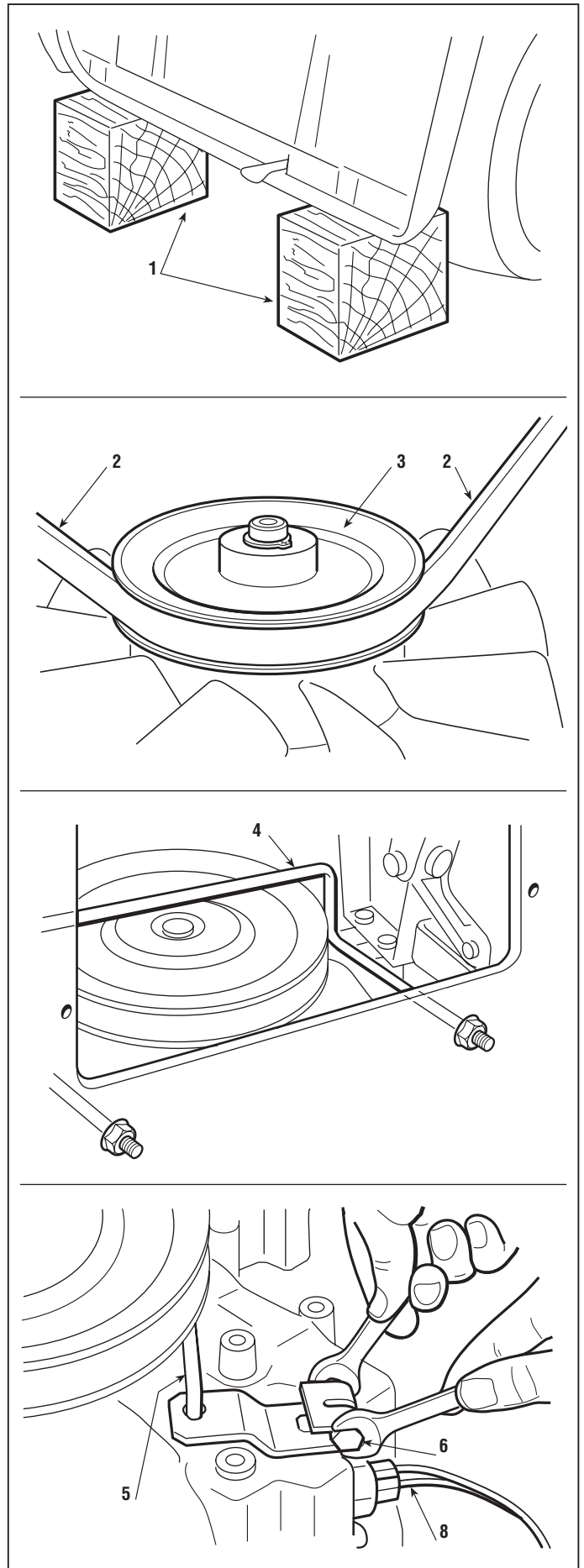

REMOVAL OF THE REAR AXLE



5.6
1



from 2007 to
page 2 / 3

The unit is supported by two brackets (9) with their screws (10) and (11) and is attached to the frame by four screws (12).

Loosen the two screws (10) to give a minimum of movement to the brackets (9) and undo the two screws (11). Then carefully loosen the four lower screws (12), holding up the unit so that it does not fall.

► **In hydrostatic drive models:**

Dismantle the pin of the brake control rod (13) and the pin of the drive engagement control rod (14). Loosen the nut (15) of the release lever to detach the rod (16) from the lever (17).

The unit is held up by a support (18) and fastened to it by a screw with a nut (19), and it is attached to the frame by four screws (20).

Undo the nut (19) and then carefully undo the four lower screws (20), holding up the unit so that it does not fall.

To reassemble, reverse the order of the previous operations, taking particular care with the two self-tapping screws (11) which, if not screwed in correctly, could damage the threads inside so preventing it from being fastened properly.

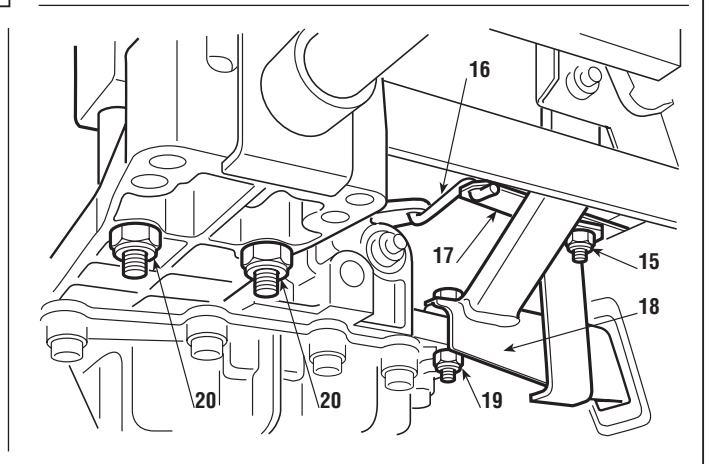
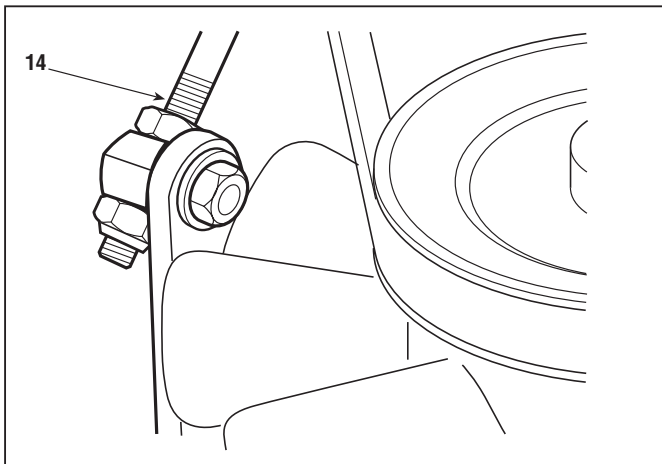
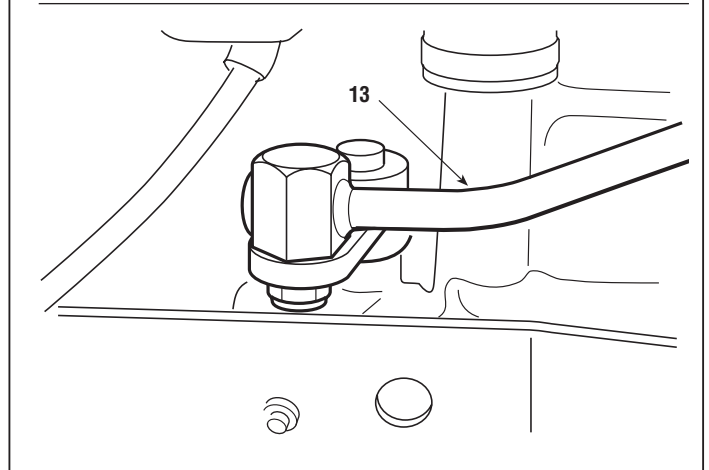
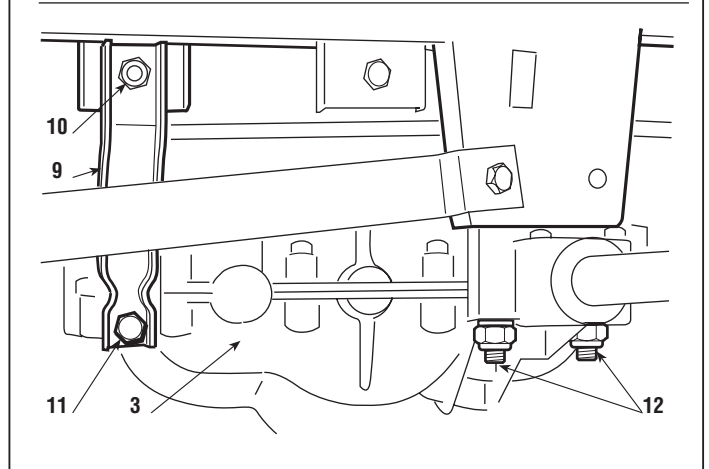
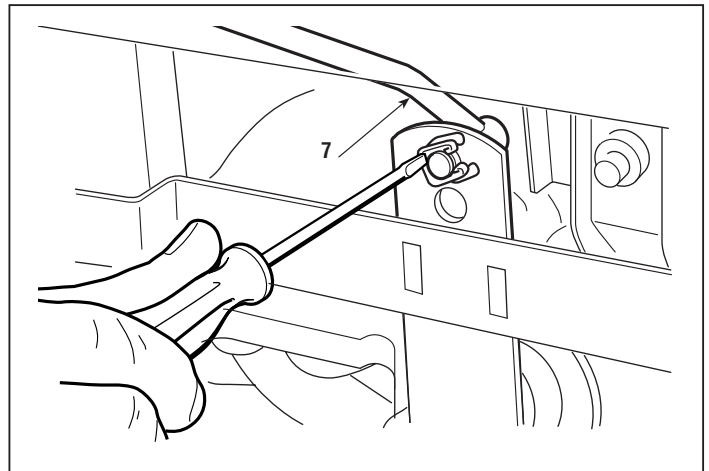

REMOVAL OF THE REAR AXLE

5.6

1

from 2007 to

page 3 / 3

Check that the spacers (21 – 22 – 23) are correctly fitted to the shafts, in the sequence given.

Reattach all the connections, and then ...

☛ Check the brake [see 4.2]

► **In hydrostatic drive models:** if the control rod has been replaced or completely pulled down:

☛ Adjust the travel and the position of “neutral” for the pedal [see 4.4].

When assembly is completed ...

☛ Refit the collector channel [see 5.3].

☛ Refit the rear wheels [see 6.1].

► **In mechanical drive models:**



IMPORTANT

If the Dana group needs to be replaced with a Peerless group or vice versa, ALWAYS also replace:

- the gear control shaft (5);
- the fastening screws (12);
- the spacers (21 - 22);

as indicated in the Spare parts catalogue.

Furthermore, ALWAYS:

☛ Proceed with the brake adjustment [vedi 4.2]

☛ Adjust the drive engagement [vedi 4.3].

► **In mechanical transmission models:**

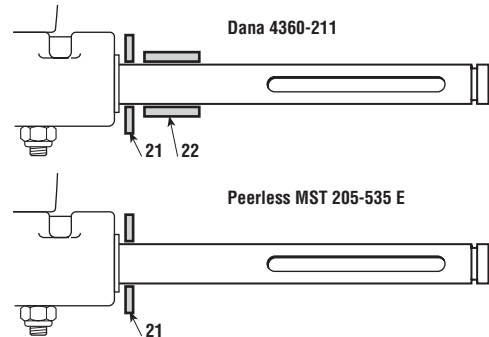

► **In hydrostatic transmission models:**

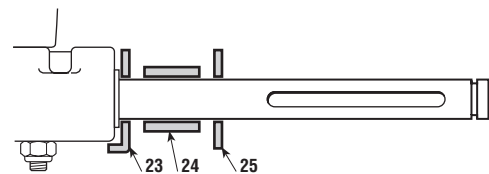

Tightening torques

10	Screws for brackets	25 ÷ 30 Nm
11	Self-tapping screws	25 ÷ 30 Nm
12-20	Screws for rear axle fastening ..	25 ÷ 30 Nm
19	Rear axle locknut	25 ÷ 30 Nm

REMOVAL OF THE CUTTING DECK

5.7
0

from 2007 to
page 1 / 1

5.7 REMOVAL OF THE CUTTING DECK

*Removing the cutting deck facilitates all the overhaul and replacement of hubs, bearings and blade shafts.
With some practice and experience it is possible to do this work with the deck still in position.*

➡ Remove the collector channel [see 5.3]

Free the blade belt (1) from the clutch pulley (2) and set the cutting height adjustment lever to position "1".

Unscrew the nut (3) and disconnect the steering rod (4) to allow the passage of the belt.

Uncouple the two front flexible split pins (5) and the three flexible split pins (6) of the lifting tie-bars.

Having checked that there are no obstacles, the plate can be removed, slightly rotating it anticlockwise, so that all the pins come out of their housings.

For reassembly perform the operations described above in reverse, making sure that the blade control belt (1) remains above the steering rod (4).

IMPORTANT – It is always advisable to replace the nut (3) whenever it is dismantled.

When assembly is completed ...

➡ Reattach the collector channel [see 5.3].

➡ Check the alignment of the cutting deck [see 4.5].

Tightening torque

3 Steering rod fixing nut 18 ÷ 20 Nm

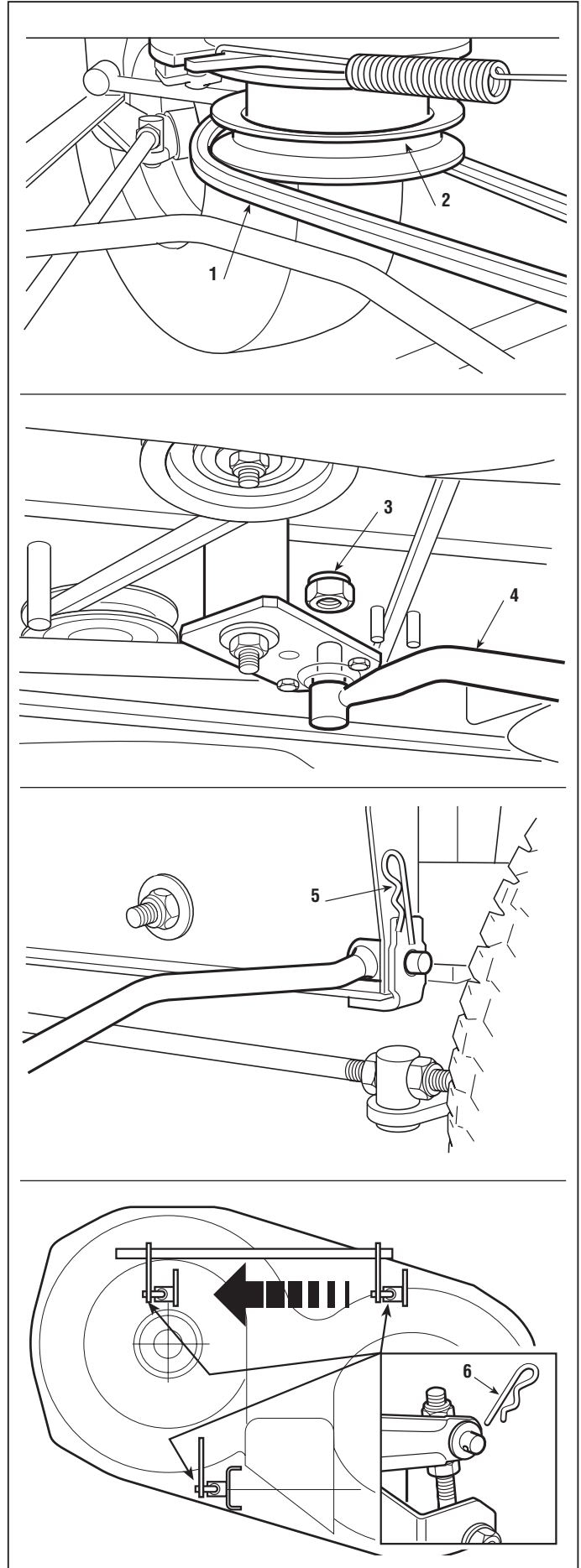

REPLACEMENT OF TYRES AND WHEELS

6.1
0

from 2007 to
page 1 / 1

6.1 REPLACEMENT OF TYRES AND WHEELS

A) Tyres

The tyres used are of the «Tubeless» type and so every repair of a hole in the tyre must be done by a tyre specialist according to the methods used for this type of tyre.

After replacing one or more tyres or the wheels, it is always necessary to check the pressure and to check the alignment of the cutting deck [see 4.5].



WARNING

Replace distorted wheel rims as they could impair the tyre's hold.

B) Wheels

The wheels are held by a snap ring (1) which can be removed with the help of a screwdriver.

NOTE

If a wheel is jammed onto the shaft, use a releasing spray directing around the splining hole.

On assembly it is advisable to spread grease on the shaft to facilitate the next wheel removal.

For the front wheels: replace the shoulder washer (2) and the flexible ring (1) with the bevel facing inwards.

For the rear wheels: replace the shoulder washer (2) and the flexible ring (1) with the bevel facing inwards and check the axial gap of the wheel on the shaft; if it is greater than 3 mm, a spacer (3) must be fitted between the wheel hub and the shoulder washer (2).

Tyre pressures

Front	(Tyres 13 x 5.00-6) 1,5 Bar
	(Tyres 15 x 5.00-6) 1,0 Bar
Rear	1,2 Bar

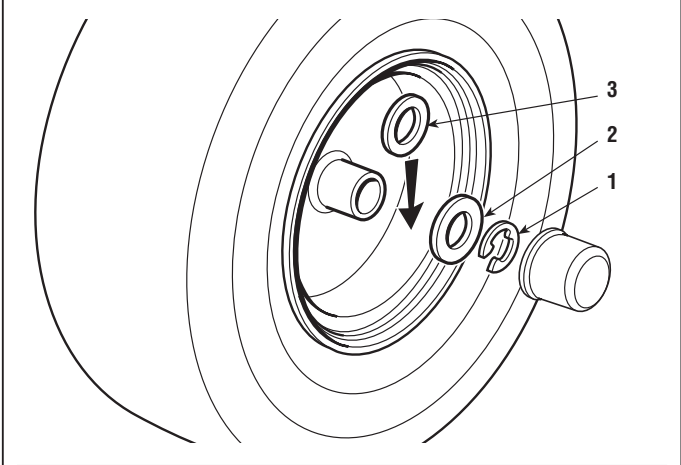
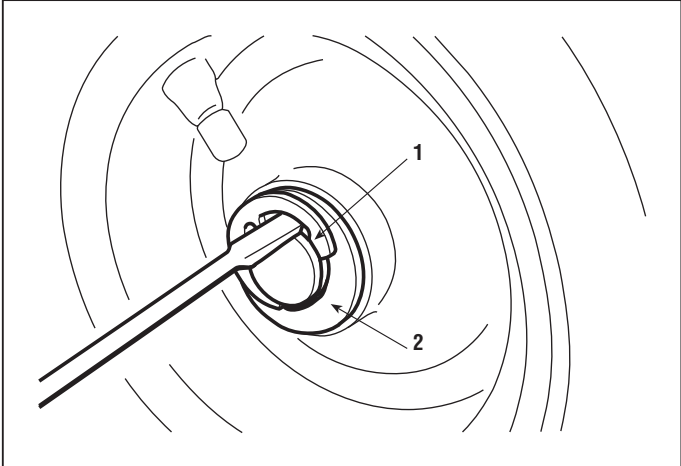

6.2 REPLACEMENT OF FRONT WHEEL BEARINGS

➡ Dismantle the front wheel [see 6.1].

The front wheel bearings (1) are force splined into the front wheel hub.

To be able to remove a bearing a 10 - 12 mm round bar (2) is needed. Insert this from the opposite side and hammer it on various points around the internal circumference of the bearing.

The new bearing must be inserted with the help of a plastic mallet or a bronze pad (3) **working only on the outer ring of the bearing.**

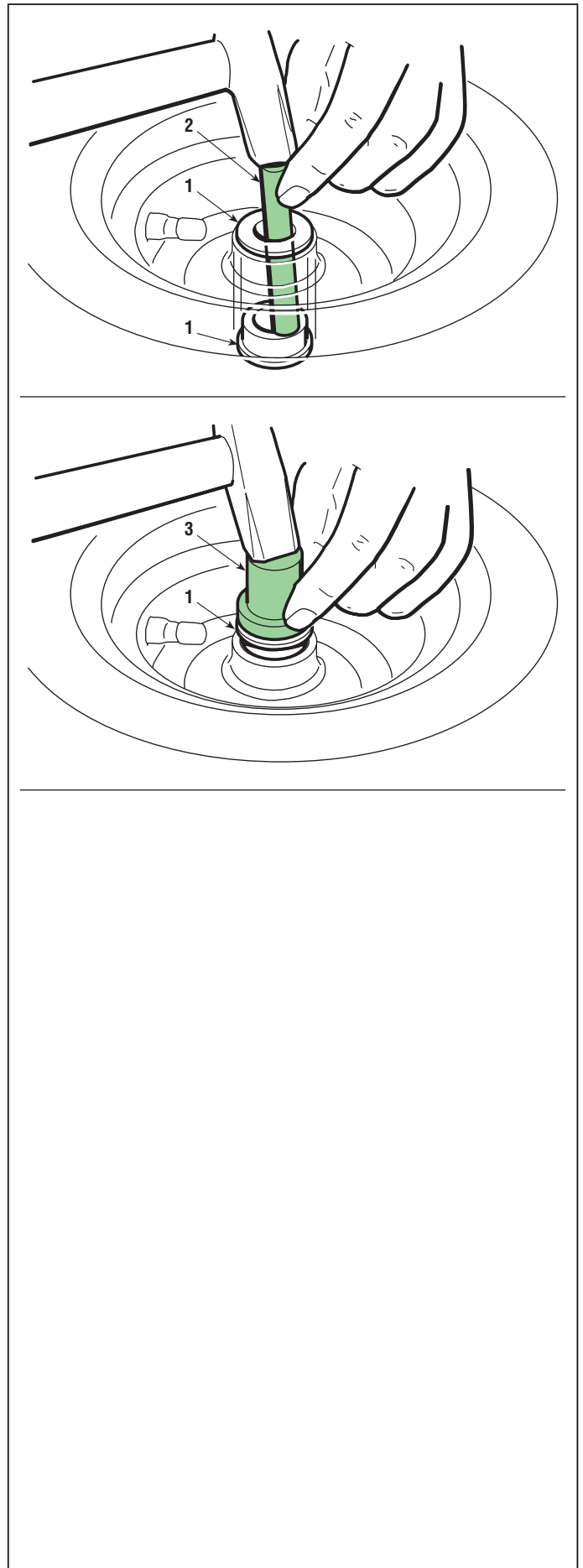

DISMANTLING OF THE STEERING COMPONENTS

6.3

0

from 2007 to

page 1 / 2

6.3 DISMANTLING STEERING COMPONENTS

Remove the inspection hatch, slacken off the register (1) and unhook the spring (2) of the traction pulley guide.

Uncouple the spring (3) and lift the steering column (4) by enough to be able to remove the pinion (5).

A) Dismantling the steering crown wheel and pinion.

Working from the bottom of the machine, unscrew the nut (3), being careful to adequately support the crown wheel axle components to prevent them from unthreading themselves completely.

Remove the screw (7) and washer (8) dismantle the crown wheel (9).

In the case of replacement of the crown wheel and pinion, the 0.8 mm spacer (10) (that might have been placed under the crown wheel previously) must be recovered.

On assembly, check the grease charge inside the sleeve (11) and top it up, if necessary, through the grease nipple (12).

With the new crown wheel and pinion, the spacer (10) must be placed between the crown wheel (9) and the washer (8), so that it can be used subsequently for taking up the play between the teeth; should the same components be refitted, the play between the teeth must be evaluated and the spacer (10) possibly fitted below the crown wheel (9) should it be necessary to reduce the play.

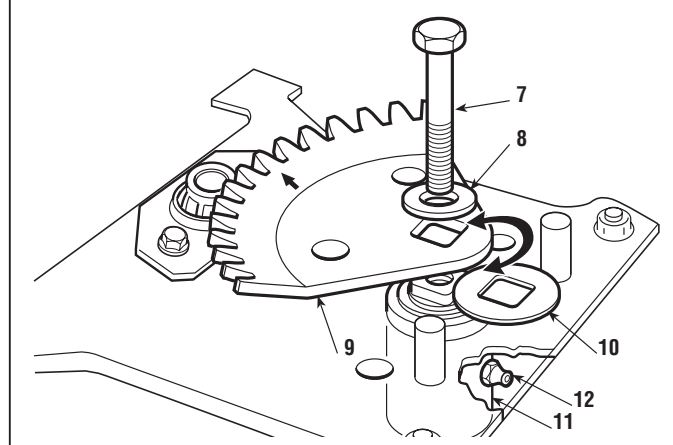
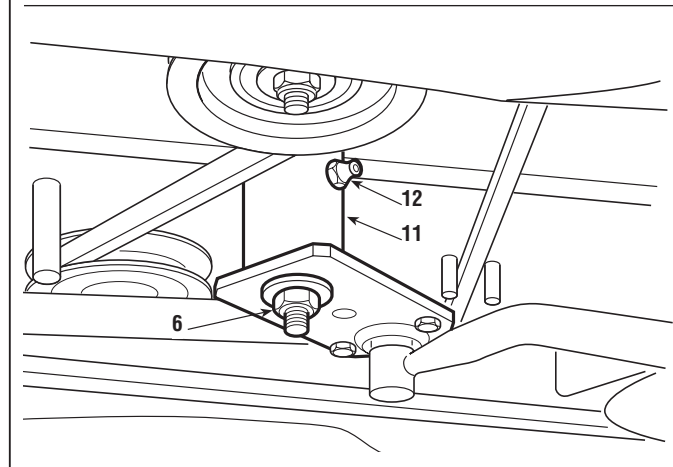
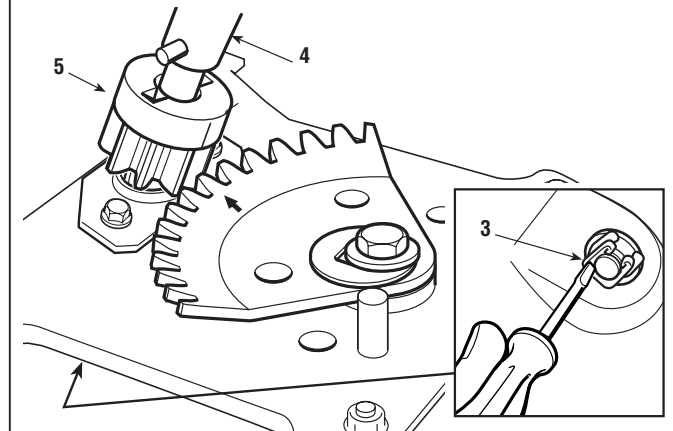
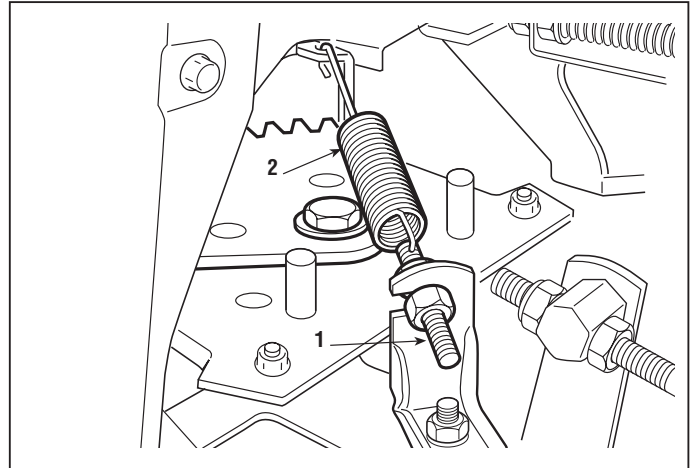

DISMANTLING OF THE STEERING COMPONENTS

6.3
0

from 2007 to
page 2 / 2



Refit the crown wheel (9), matching up reference (→), punched in the centre, with reference (I) of the pinion (5).

Refit screw (7) and nut (6), tightening it to the pre-scribed value.

B) Lower bush replacement

Use a universal socket wrench to unscrew the two screws (14) that fix the plate (15) and remove the spherical lower bush (16).

On reassembly ensure that the bush (16) is fitted with the protuberant part upwards.

Refit the plate (15) without tightening the screws (14).

Align the pinion with the crown wheel [see 6.3.A] and insert the end of the steering wheel column (3) in the hole in the spherical bush (16); fully tighten the screws (14) after having checked the correct alignment and regular rotation of the steering wheel column.

Replace the traction guide pulley spring (2) and ...

➡ Adjust the traction engagement [see 4.3].

➡ Check the steering geometry [see 4.7].

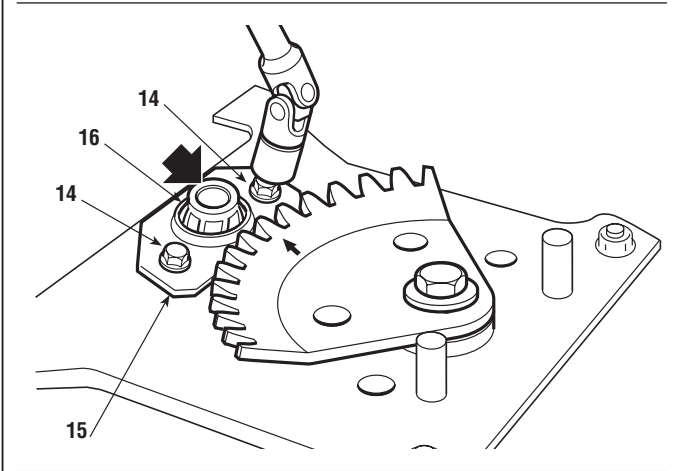
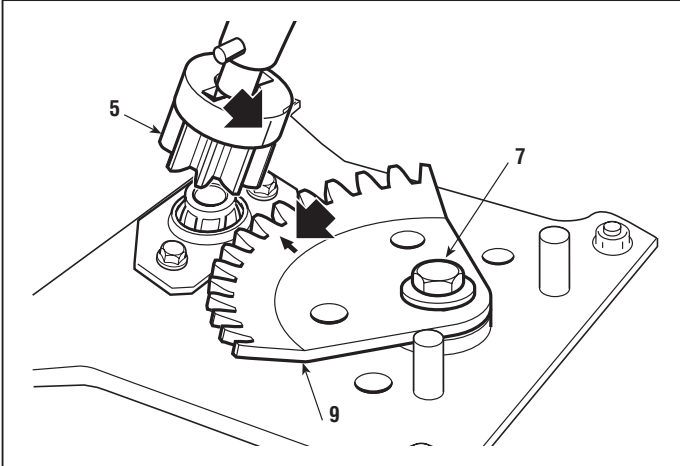

Tightening torques

6	Nut for Ring gear	35 ÷ 40 Nm
---	-------------------------	------------

REPLACEMENT OF THE DRIVE BELT

6.4

1

from 2008 to

page 1 / 1

6.4 REPLACEMENT OF THE DRIVE BELT

- Remove the collector channel [see 5.3].
- Dismantle the engine pulley and the clutch [see 5.5] to free the belt.

To allow removal of the belt and subsequent passage of the new belt also requires:

- unscrewing the nut **(1)** and disconnecting the steering rod **(2)**;

Loosen the nuts **(5)** holding the small side wheels **(6)** in order to release the belt, take off the drive pulley **(7)** and the stretcher pulley **(8)** held on by the nuts **(9)** and **(10)**.

➤ **In mechanical drive models:** you need to dismantle the guide pulley **(11)** attached to the rear plate.

When reassembling, make sure that the belt **(12)** is correctly positioned in the pulleys inside the rims, taking particular notice of where it passes through the fork **(13)**.

IMPORTANT – It is always advisable to replace the nut **(1)** whenever it is dismantled.

When reassembled, ...

- Refit the engine pulley and the clutch [see 5.5].
- Adjust the drive engagement [see 4.3].
- Refit the collector channel [see 5.3].

Tightening torques

1 Steering rod fixing nut.....	18 ÷ 20 Nm
5 Nuts for small wheels.....	25 ÷ 30 Nm
9 - 10 Nuts for pulleys	25 ÷ 30 Nm

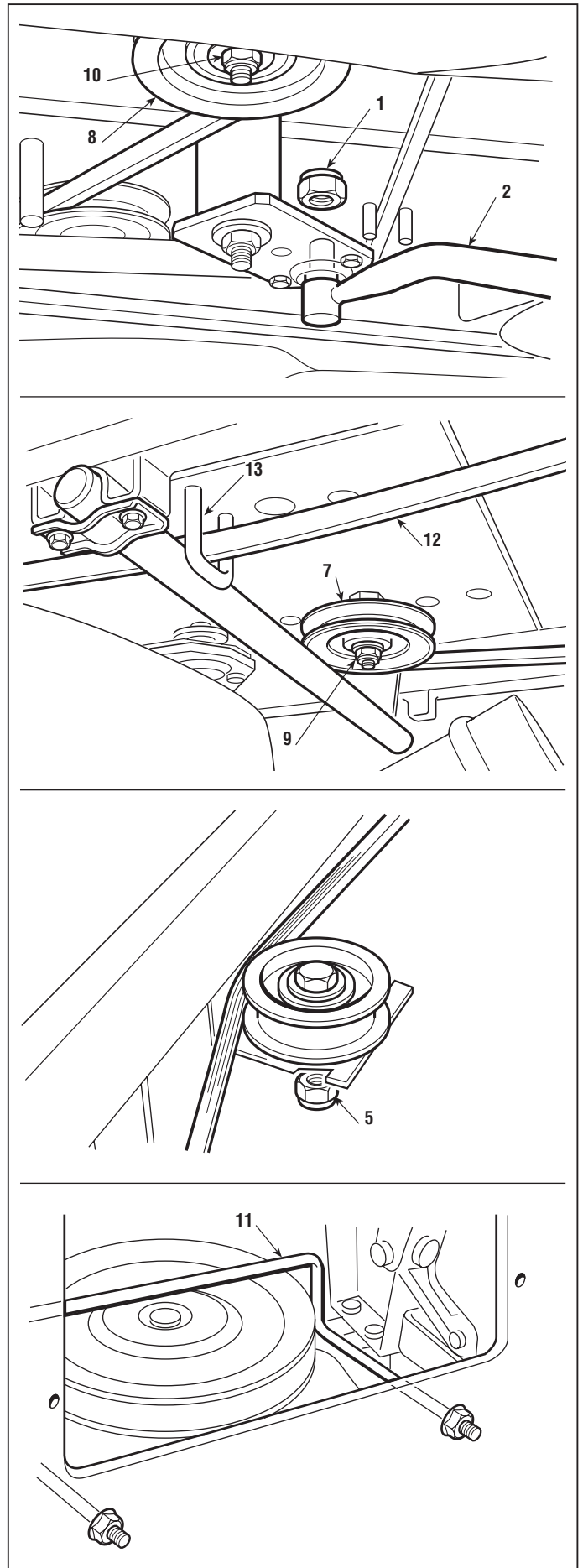

REPLACEMENT OF THE SMALL WHEELS FOR THE DRIVE BELT

6.5
0

from 2007 to
page 1 / 1

6.5 REPLACEMENT OF THE SMALL WHEELS FOR THE DRIVE BELT

➡ Remove the collector channel [see 5.3].

For greater operating convenience it is recommended that the transmission belt is slackened off; this is done by ...

➤ **In mechanical transmission models:** In mechanical transmission models: engaging the parking brake.

➤ **In hydrostatic transmission models:** grasping the two branches of the belt (2), pulling it just enough to free it from the pulley throat (3), overcoming the resistance of the tension regulator guide pulley.

The two wheels (3) are held onto the frame by two nuts (4), with a spacer in between (5).

When reassembling, there should be kept in mind that:

- the tall spacer (5a) is to be fitted beneath the right-hand wheel (3a);
- the short spacer (5b) is to be fitted beneath the left-hand wheel (3b);

When reassembly is completed, tighten the nuts (4) to the amounts shown.

At the end...

➡ Adjust the drive engagement [see 4.3].

➡ Refit the collector channel [see 5.3].

Tightening torque

4 Nuts for small wheels.....	25 ÷ 30 Nm
------------------------------	------------

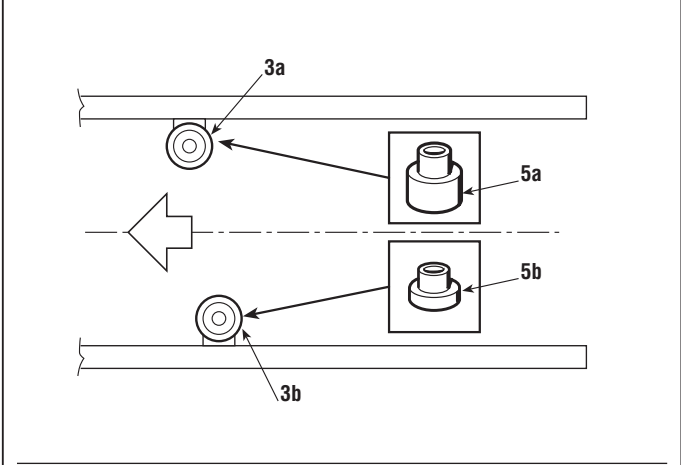
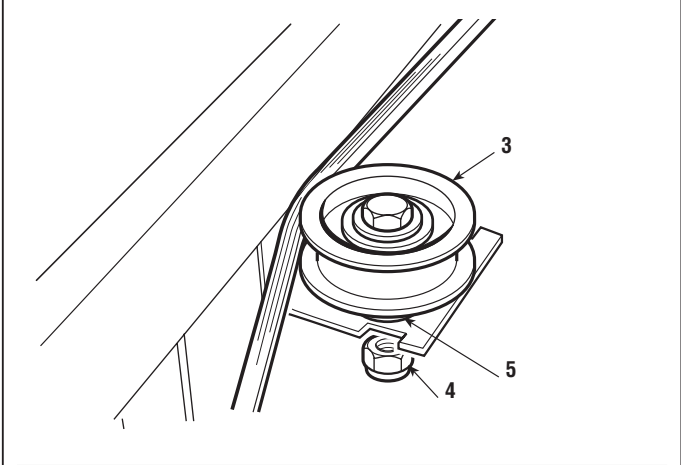
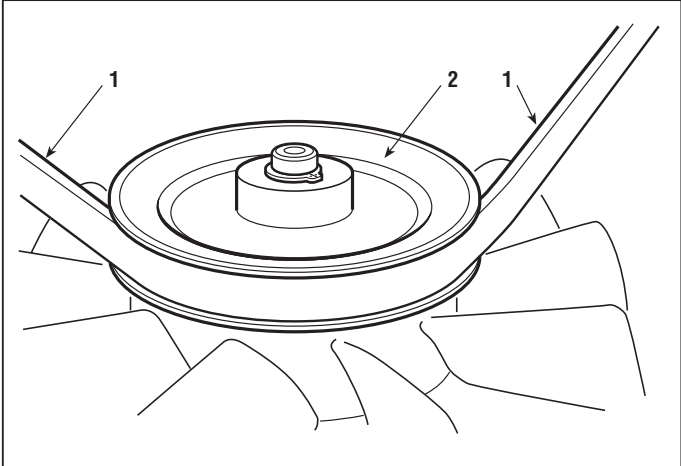

REPLACEMENT OF THE BLADES BELT

6.6

1

from 2007 to

page 1 / 1

6.6 REPLACEMENT OF THE BLADES BELT

Remove the right (1) and left (2) guards fixed by the relative screws and/or nuts.

N.B. – The blade guards could have different configurations and fixings; in any case they must both be removed, after having identified all the fixing points.

Free the blade belt (3) from the clutch pulley (4).

Unscrew the nut (5) and disconnect the steering rod (6) to allow passage of the belt.

Loosen the left belt guide (7) fixed by two nuts (8).

At this point the tension regulator guide pulley can be distanced manually and the belt (9) unthreaded and replaced.

For reassembly perform the operations described above in reverse, making sure that the blade control belt (9) remains above the steering rod (6).

IMPORTANT – It is always advisable to replace the nut (5) whenever it is dismantled.

Once assembly is completed ...

➔ Adjust the blade engagement [see 4.1].

Tightening torque

15 Steering rod fixing nut 18 ÷ 20 Nm

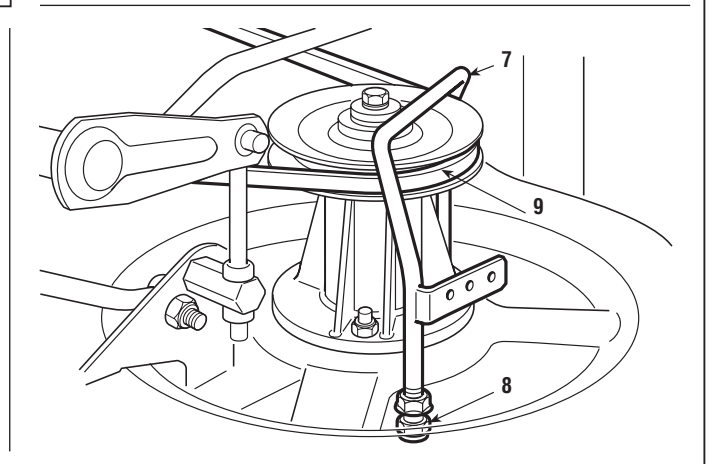
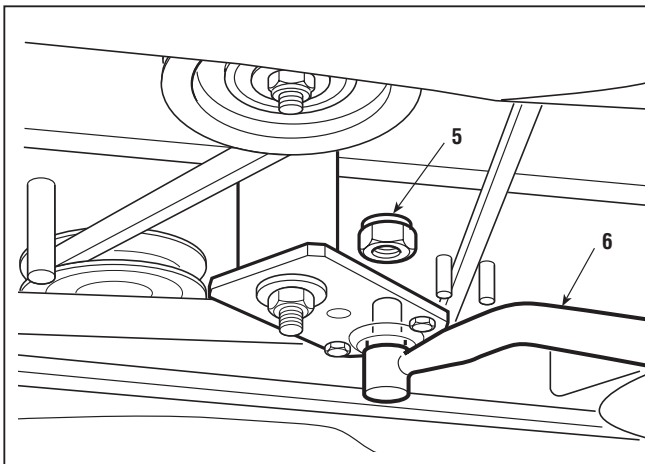
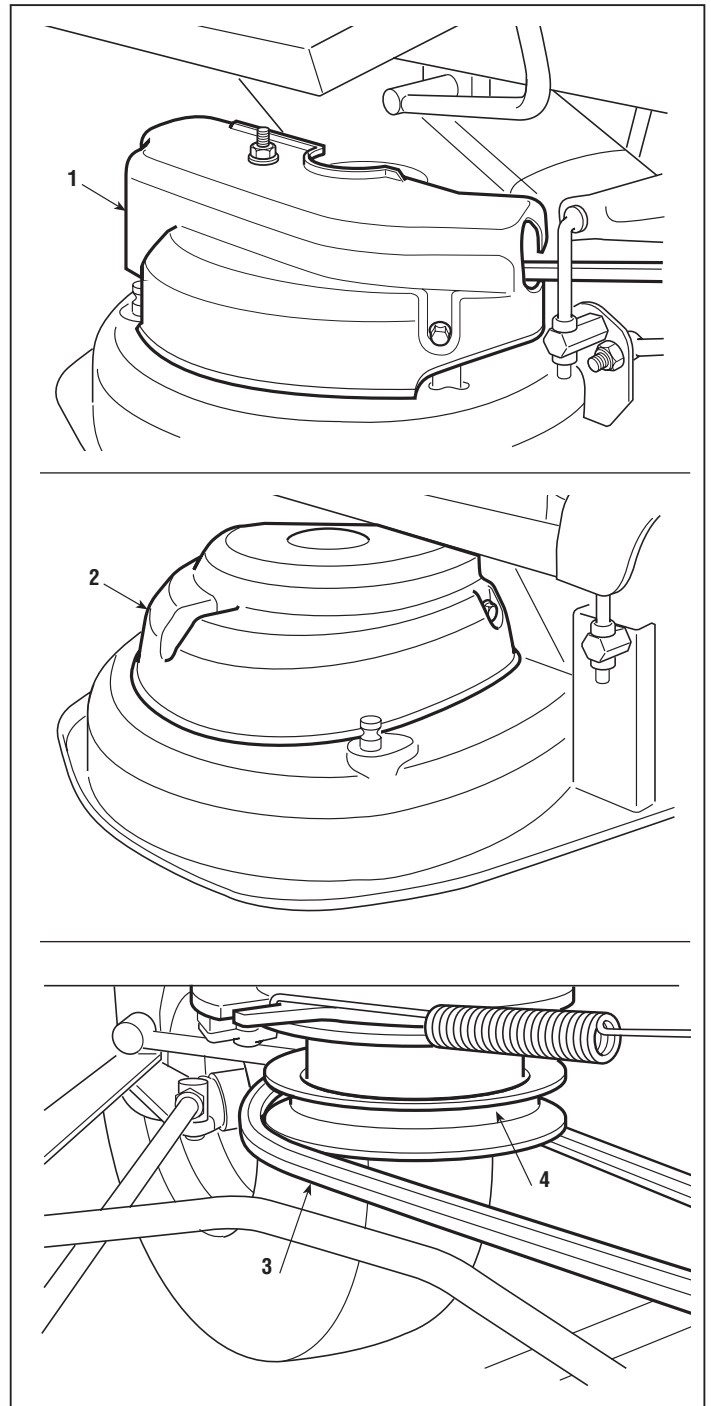

REPLACEMENT OF THE SUPPORTS AND SHAFTS OF THE BLADES

6.7
0

from 2007 to
page 1 / 2

6.7 REPLACEMENT OF THE SUPPORTS AND SHAFTS OF THE BLADES

➡ Remove the cutting deck [see 5.7].

NOTE

This operation is not strictly necessary since, with a little practice and experience, it is possible to dismantle the deck supports without removing the deck.

➡ Remove the blades [see 4.9] and take off the hubs.

Remove the right (1) and left (2) guards fixed by the relative screws and/or nuts.

N.B. – The blade guards could have different configurations and fixings; in any case they must both be removed, after having identified all the fixing points.

Free the blade belt (3) from the clutch pulley (4) and set the cutting height adjustment lever to position "1".

Remove the left belt guide (5) fixed by two nuts (6).

Unscrew the central screws (7) and unthread the pulleys (8).

Dismantle the flange support (9) by unscrewing the three nuts (10).

The entire support (11), including shafts and bearings, is a spare part available as single assembly unit.

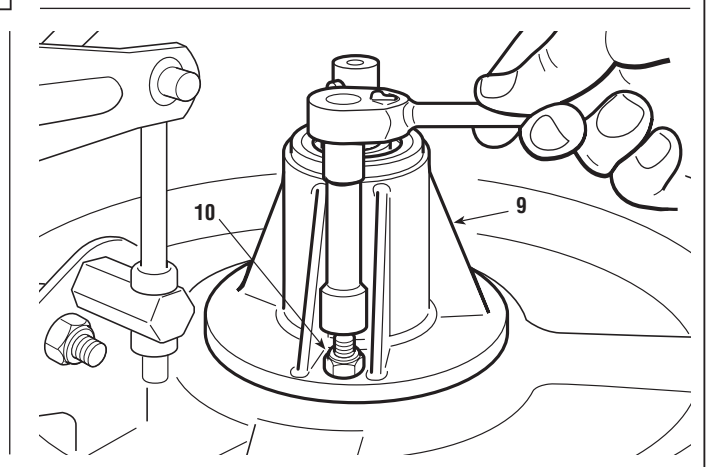
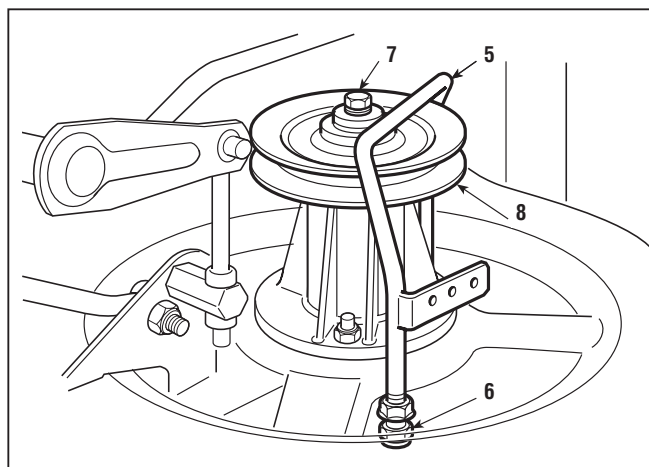
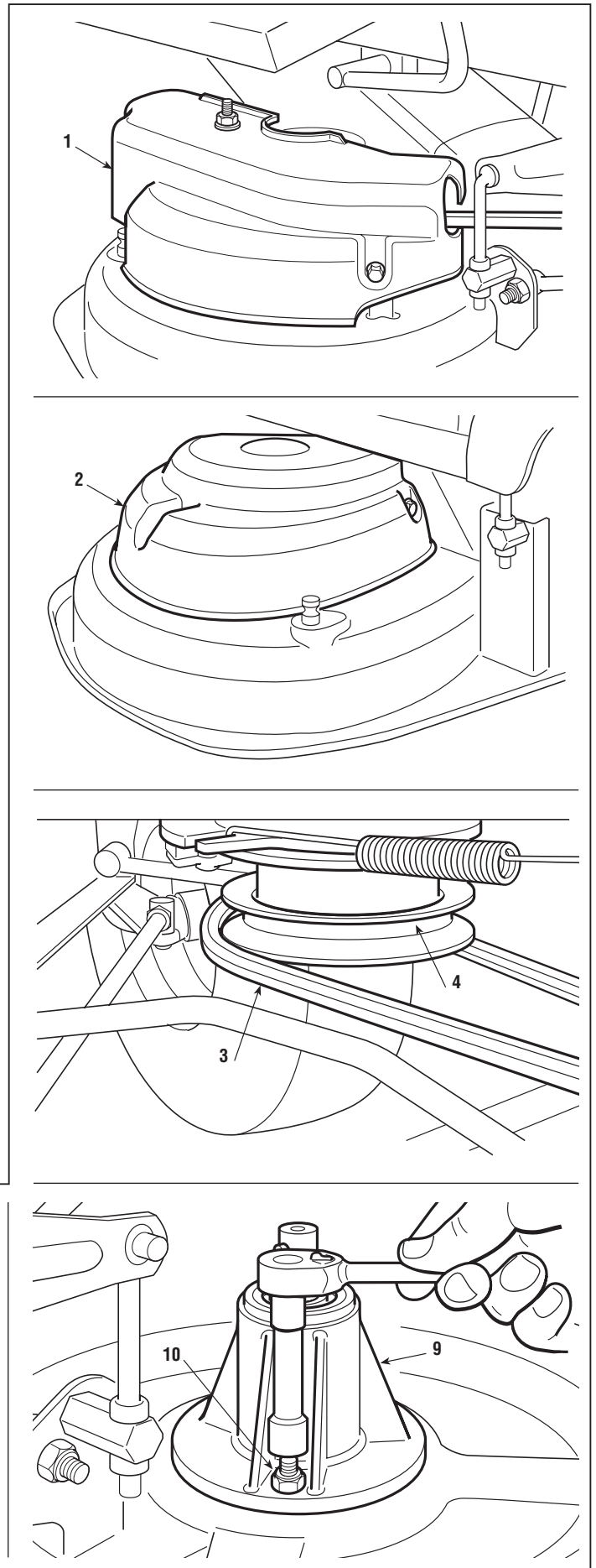

REPLACEMENT OF THE SUPPORTS AND SHAFTS OF THE BLADES

6.7
0

from 2007 to
page 2 / 2

If you should want to just replace the shaft or bearings, remove the key (11) and hit the shaft with a plastic mallet on the pulley side in order to remove the shaft together with the lower bearing (12).

After having removed the snap ring (13), the dust cover (14) and the spline (15), the bearing (12) splined onto the shaft can be removed using a normal extractor, taking care to close up the threaded hole (16) with a screw to prevent the point of the extractor from damaging the thread.

The second bearing still in place must be removed by hitting it from the inside of the flange using a 12 ÷ 15 mm diameter round bar (17).

On reassembling, first put the shaft into the hole of the lower bearing and insert this into the support. Fit on the upper bearing and, using the special bush (18) which works on the inner ring, hit it squarely with a mallet until the bearing is fully driven home.

The right and left shafts seem to be the same, but can be differentiated as follows:

- **right shaft:** red paint on the pulley side;
- **left shaft:** green paint on the pulley side.

Before refitting the support assembly, check that these positions are correct.

Fit the flange supports onto the deck, **fully tightening the nuts (10)**.

On completion of assembly of the supports, ...

➡ Reassemble the hubs and start sharpening, balancing and assembling the blades [see 4.9].

Tightening torques

7 Screws for pulleys fastening	20 ÷ 25 Nm
10 Nuts for flanged support	25 ÷ 30 Nm

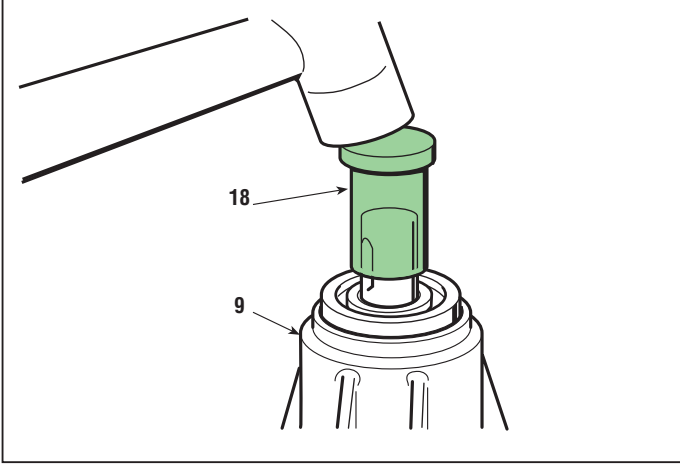
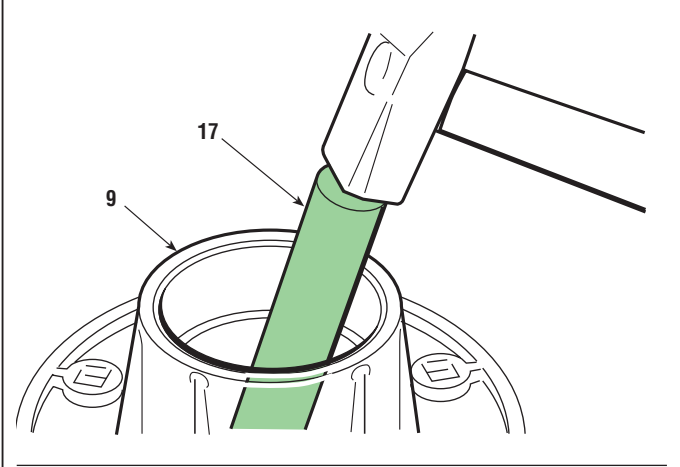
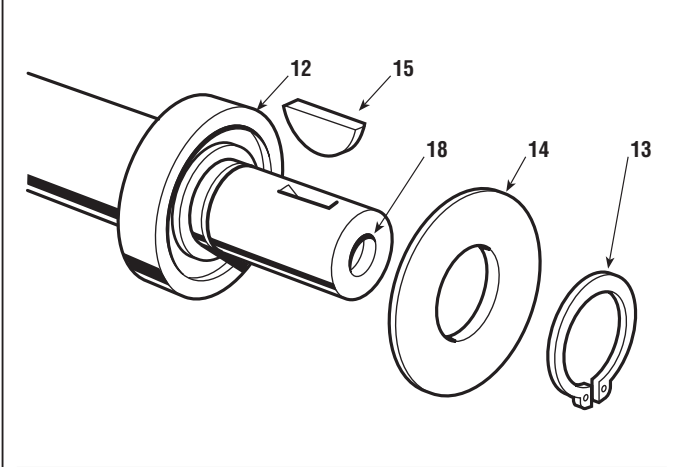
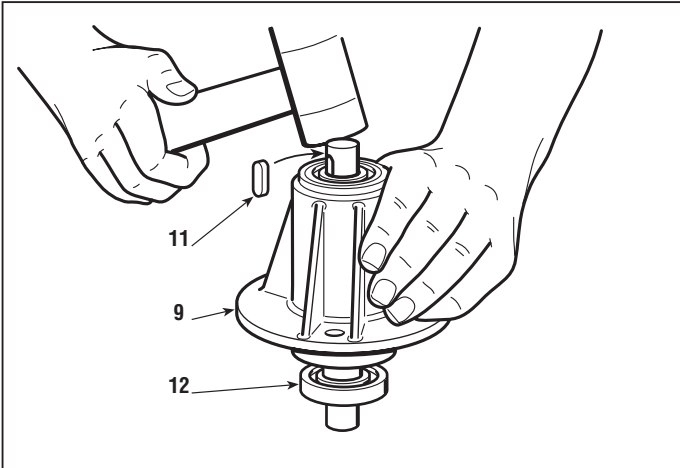

REPLACEMENT OF THE ACCELERATOR

6.8

1

from 2007 to

page 1 / 1

6.8 REPLACEMENT OF THE ACCELERATOR

Remove the steering wheel, unthreading the pin (1).

Remove the small knob (2) and disconnect the end of the cable (3) from the engine connection terminal (4).

The dashboard is fixed by two screws (5) from the seat side and another two screws (6) inside the engine compartment.

Move the dashboard by the amount necessary to access the screws (taking care over the electric cables), unscrew the two fixing screws (7) and unthread the accelerator (8) together with the cable.

On assembling, put the accelerator lever in the «MINIMUM» position, connect the end of the wire (5) to the terminal (6) on the engine after having moved the cursor (9) in the same «MINIMUM» position specific to each type of engine and shown in the instruction booklet.

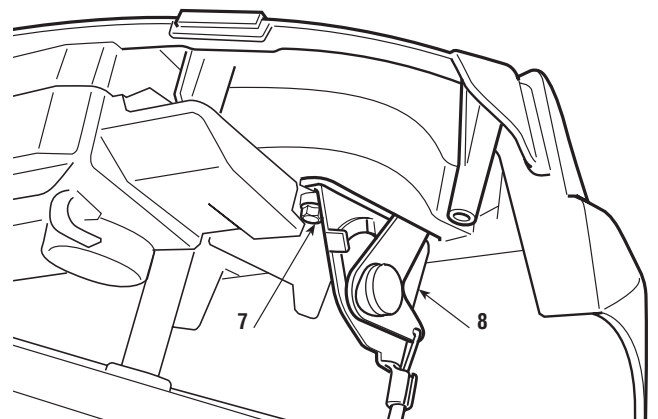
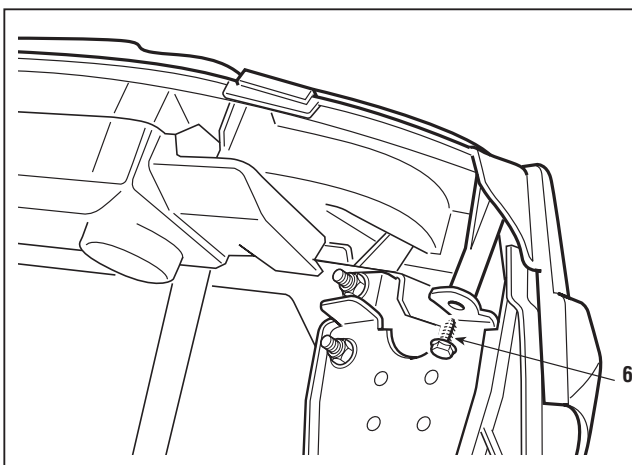
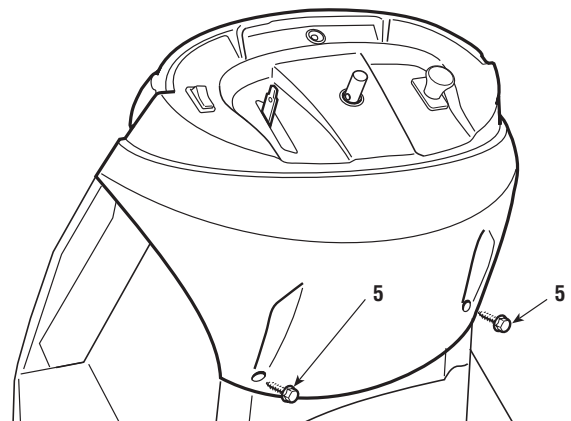
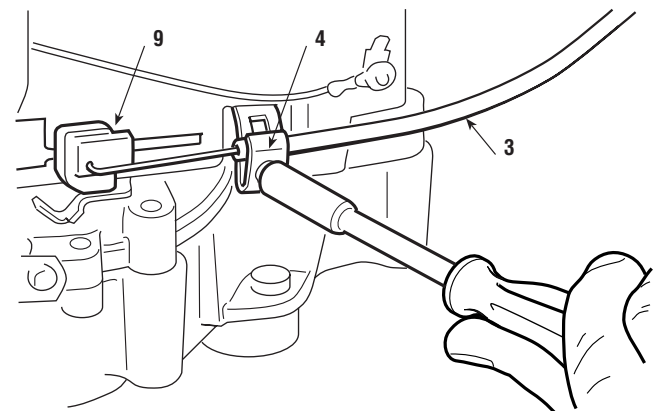
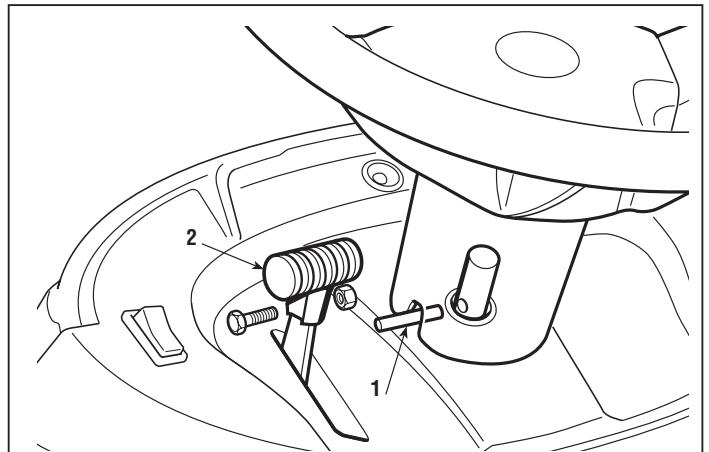

REPLACEMENT OF THE BRAKE PADS AND DISC

6.9

0

from 2007 to

page 1 / 1

6.9 REPLACEMENT OF THE BRAKE PADS AND DISC (► *In mechanical drive models*)

➡ Remove the left-hand rear wheel [see 6.1].

Disconnect the control rod (1) from the lever (2) and undo the two screws (3) which hold on the support (4).

The support (4) contains a pad (5a) separated from the control pistons (6) by a plate (7).

The other pad (5b) can be reached by taking off the disc (8).

If there is oil on the pads, clean with solvent and go over them with fine-grade abrasive paper.



Both pads should be replaced if the depth of either of them is less than 5 mm.



Renew the disc if it is damaged, distorted or less than 4 mm thick.

On reassembly, carefully reposition all the components and refit the complete support. When connecting the rod (1) be sure to use the upper hole in the lever (2).

NOTE

During all these operations it is better to not unscrew or loosen the central screw (9) to avoid altering the calibration of the cam driving the pistons.

If it has been moved, the lever's free movement will have to be checked [see 4.2].

When fully reassembled ...

➡ Check the brake adjustment [see 4.2].

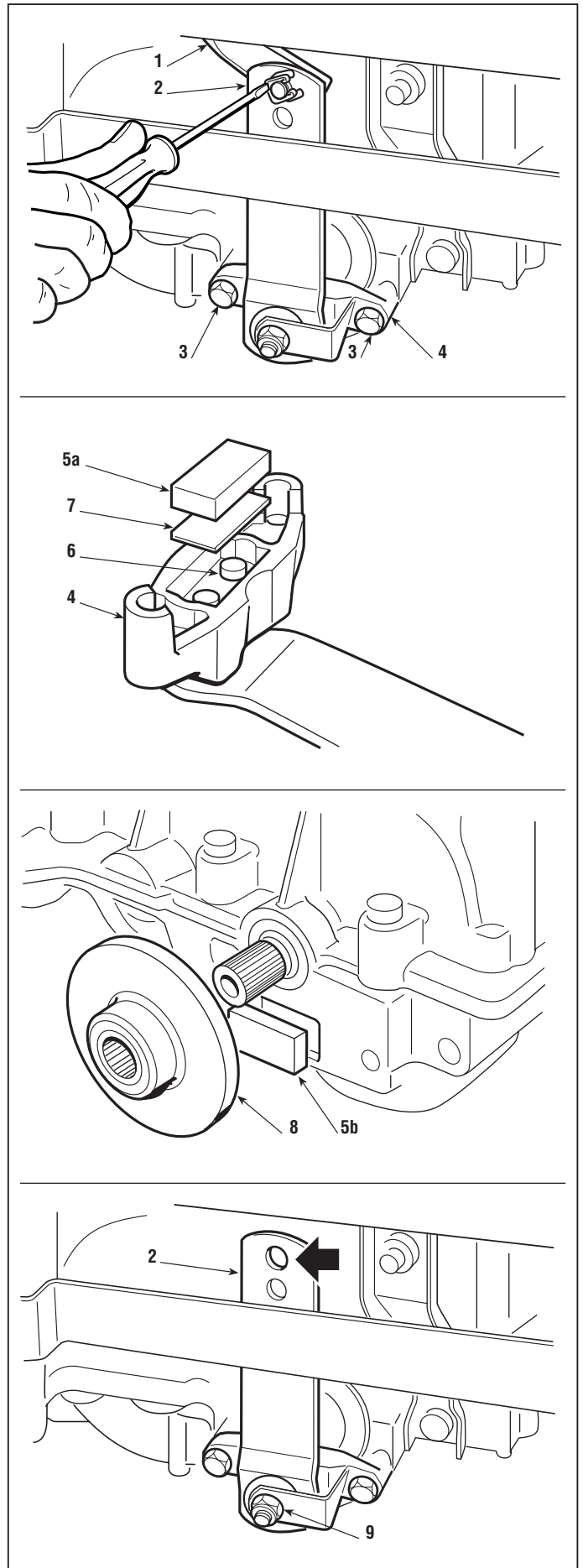

GUIDE TO THE IDENTIFICATION OF PROBLEMS IN THE ELECTRICAL SYSTEM	◀	7.1	▶	from 2008 to
	◀	1	▶	page 1 / 3 ▷

7.1 GUIDE TO THE IDENTIFICATION OF PROBLEMS IN THE ELECTRICAL SYSTEM

In the following some of the problems connected to the malfunctioning of the electrical system are shown, with their probable cause and the remedial action to be taken. Should the problem continue after the appropriate checks, seek assistance from your local Service Centre.

Faulty electronic cards must always be replaced without trying to repair them or replace single components.

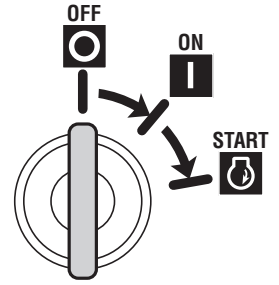

PROBLEM	CAUSE	REMEDY
1. Activation of the self-resetting protection ¹⁾		
a).... on inserting the key in position «ON»	Battery terminal crossed	Check the battery connections
	Short circuit to earth	Check the connectors and wiring of the microswitches.
b) ... in position «START» or after a few seconds' use:	Sulphated battery (it no longer accepts recharging)	Replace the battery
	Faulty or wet electronic card	Check and dry with low pressure tepid air (hair-dryer)
	Disconnected or missing battery	Reconnect the battery, which must always be connected
	Battery terminals corroded or with poor contact	Check and clean the connections
c) ... after several minutes' use:	Poor or missing earth contact on the charge regulator	Check the earth connections and the screws fastening the regulator
	Overvoltage from a malfunction in the regulator	Check the recharge circuit [see 7.8]
	Battery disconnected or faulty during use	Check the battery or wiring
2. With the key in the "ON" position the pilot lamp (led 1) or dashboard (led 6) remain off	The battery is not supplying the card	Check the connection cables Check the battery's condition [see 7.9]
	Battery or card not earthed to frame	Check and put right
	10 A fuse blown	Replace fuse
	Battery terminal crossed	Check connections.
3. The pilot lamp (led 1) or dashboard (led 6) come on but, with the key in the "START" position, the starter motor does not turn or lacks power (poor starting)	The battery is not supplying sufficient current	Recharge the battery [see 7.9]
	Badly earthed battery, or the starter relay or motor not earthed	Check and put right
	Defect in the starter relay	Check that the starter relay is activated [see 7.6]

¹⁾ Activation of the self-resetting protection of the electronic card is signalled by the failure of the LED to light, by it switching off during work, by the engine running erratically or stopping.

GUIDE TO THE IDENTIFICATION OF PROBLEMS IN THE ELECTRICAL SYSTEM

7.1

1

from 2008 to

page ◀ 2 / 3 ▶

PROBLEM	CAUSE	REMEDY
4. The pilot lamp (1 led) is flashing with the key in the "START" position and the starter motor does not turn	Starting not permitted [see summary logic table 7.2]	After checking that the conditions are met, check all the microswitches [see 7.3] and the relative wiring.
	No fuel flow	Check the leads for the carburettor solenoid valve opening control (if provided) or check the fuel stopcock and filter.
5. The starter motor turns but the engine does not start	Impaired starter system	Check that spark plug caps are positioned correctly
		Check that the spark plug electrodes are clean and have the correct gap.
6. The starter motor continues to turn after engine has started, and does not stop when the key is removed	Mechanical difficulties with the contact breakers of the starter relay	Replace the starter relay.
	Starter works erratically for mechanical or electrical reasons taking excessive current and causing binding of relay contacts	Check the starter motor
7. The starter motor operates as soon as the key is in the «ON» position, and can be turned off only by removing the key (pilot lamp on)	Fault in the card	Replace the card
	Starter block operating faults	Replace the block
8. The pilot lamp (led 1) or dashboard (led 6) become weak after several hours' work and the engine goes off	Insufficient charge	Check that the charging cable has not detached
		Check that there are no current leakages caused by cables with damaged insulation
		Check that the regulator is working properly [see 7.8]
	Charger fuse blown	Replace fuse (25 A) and check the recharge circuit [see 7.8]
9. The engine stops while in use for reasons not due to the safety devices cutting in	The safety devices have cut in or are faulty	Check the microswitch's operation and the relevant wiring [see 7.3 and 7.7]
	Accidental detaching of an electrical wire	Check all wiring
	Starting of engine not permitted [see summary logic table 7.2]	After checking that the conditions are met, check all the microswitches [see 7.3] and the relative wiring.

GUIDE TO THE IDENTIFICATION OF PROBLEMS IN THE ELECTRICAL SYSTEM



7.1
0



from 2007 to
page 3 / 3

PROBLEM	CAUSE	REMEDY
10. The 10 A fuse blows	Short circuit or overload on the power side of the electronic card (start-up unit, starter relay) lights and recharger connector	Find and replace the defective user [see 7.4 and 7.6]
	Short circuit or damage to the electronic card protection (power side)	Try changing the card with one that is known to work. If the problem stops, replace the faulty card
11. The 25 A fuse blows	Faults in the battery charging circuit	Replace fuse (25 A) and check the recharge circuit [see 7.8]
12. No audible signal for the "grass-catcher full" condition	Malfunctioning or faulty blade switch or microswitch and grass-catcher signalling	Check the switch, the microswitch and wiring. WARNING! – Check that the blade switch stops the engine or prevents it from being started if the acknowledgement conditions are not met [see 7.2].
	Malfunctioning or faulty electronic card	Try changing the card with one that is known to work. If the problem stops, replace the faulty card.

SUMMARY TABLE FOR THE CUTTING IN OF THE SAFETY DEVICES

7.2

1

from 2008 to

page 1 / 1

7.2 SUMMARY TABLE FOR THE CUTTING IN OF THE SAFETY DEVICES



The following tables show the various situations in which the safety devices intervene.

• **Machines with 1 led**

-/- = Uninfluential

A) STARTING («START» position)

OPERATOR	GRASS-CATCHER	BLADES	DRIVE	PARKING	ENGINE	PILOT LAMP
-/-	-/-	-/-	Engaged	-/-	DOES NOT start	Flashing
-/-	-/-	Engaged	-/-	-/-	DOES NOT start	Flashing
Absent	-/-	-/-	-/-	Disengaged	DOES NOT start	Flashing

B) WHILE CUTTING

OPERATOR	GRASS-CATCHER	BLADES	DRIVE	PARKING	ENGINE	PILOT LAMP
Absent	-/-	-/-	Engaged	-/-	Stops	ON
Absent	-/-	Engaged	-/-	-/-	Stops	ON
-/-	Missing	Engaged	-/-	-/-	Stops	ON
-/-	-/-	Engaged	-/-	Engaged	Stops	ON
Absent	-/-	-/-	-/-	Disengaged	Stops	ON

• **Machines with the dashboard with 6 led**

- Pilot lamp on
- Pilot lamp off
- * Pilot lamp uninfluential

-/- = Uninfluential

A) STARTING («START» position)



OPERATOR	GRASS-CATCHER	BLADES	DRIVE	PARKING	ENGINE	PILOT LAMPS
-/-	-/-	-/-	Engaged	-/-	DOES NOT start	*** **○
-/-	-/-	Engaged	-/-	-/-	DOES NOT start	*●* ***
Absent	-/-	-/-	-/-	Disengaged	DOES NOT start	○*** ●**

B) WHILE CUTTING



OPERATORE	GRASS-CATCHER	BLADES	DRIVE	PARKING	ENGINE	PILOT LAMPS
Absent	-/-	-/-	Engaged	-/-	Stops	*** ●○*
Absent	-/-	Engaged	-/-	-/-	Stops	**● ●**
-/-	Missing	Engaged	-/-	-/-	Stops	*●● ***
-/-	-/-	Engaged	-/-	Engaged	Stops	●*● ***
Absent	-/-	-/-	-/-	Disengaged	Stops	○*** ●**

SAFETY MICROSWITCHES AND SWITCHES OPERATION CHECK AND SWITCHES

7.3
0

from 2007 to
page 1 / 1

7.3 SAFETY MICROSWITCHES AND SWITCHES OPERATION CHECK

This check is done by disconnecting the connector and using the tester in Ohmmeter mode. This operation should be done, without the driver on board, by making contact with the ferrules on the contacts of the connector of the wiring (1) and should give this result:

N° Contacts	Tester reading and condition		
GRASS-CATCHER ATTACHED MICROSWITCH			
10 - 6	∞ (without g.catc.)	O (with g.catcher)	
SEAT MICROSWITCH			
10 - 14	∞ (absent)	O (seated)	
PARKING MICROSWITCH			
10 - 17	O (free)	∞ (engaged)	
BLADE SWITCH			
10 - 16	∞ (engaged)	O (disengaged)	
"IN NEUTRAL" SIGNAL			
10 - 7	∞ (drive)	O (neutral)	
GRASS-CATCHER FULL MICROSWITCH			
13 - Earth	O (full)	∞ (empty)	
STARTER UNIT			
+ Battery - 11	∞ (OFF)	O (ON)	O (START)
+ Battery - 11	∞ (OFF)	∞ (ON)	O (START)

ENGINE STOP

This operation must be done by keeping the connector (1) attached and should give this result:

N° Contacts	Tester reading and condition
3 - Earth	O (Always)

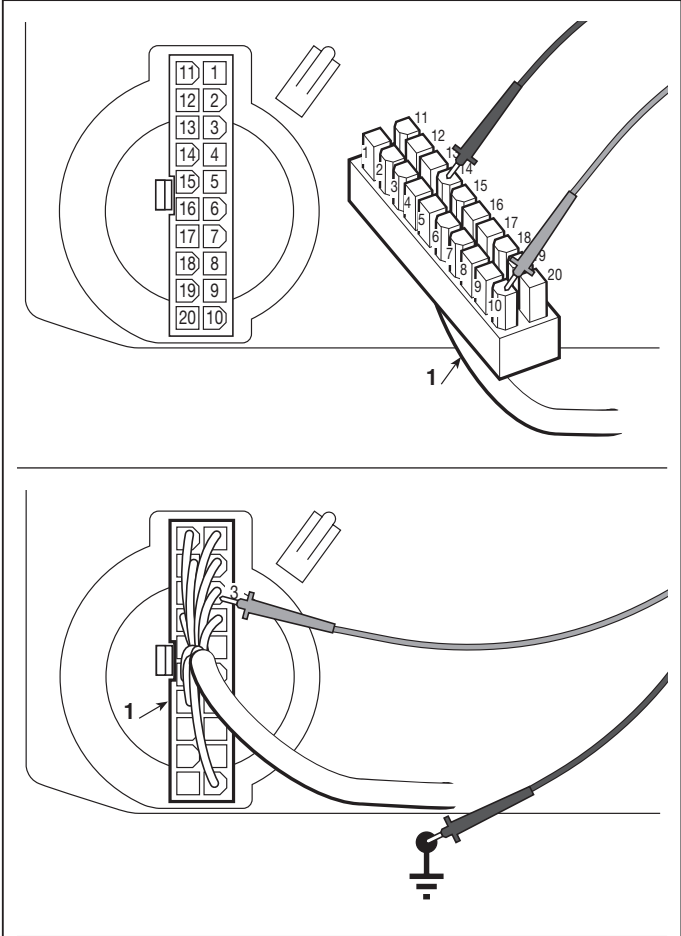

TERMINAL BOARD SUPPLY CHECK

7.4
0

from 2007 to
page 1 / 1

7.4 TERMINAL BOARD SUPPLY CHECK

This check is done with the tester in Voltmeter function (Volt DC 0 ÷ 20), with the black ferrule on terminal 1 and the red ferrule on terminal 11 of the wiring connector **(1)**.

- The key in the «ON» position.

The reading shows the battery voltage, which should never go below 11 Volts.

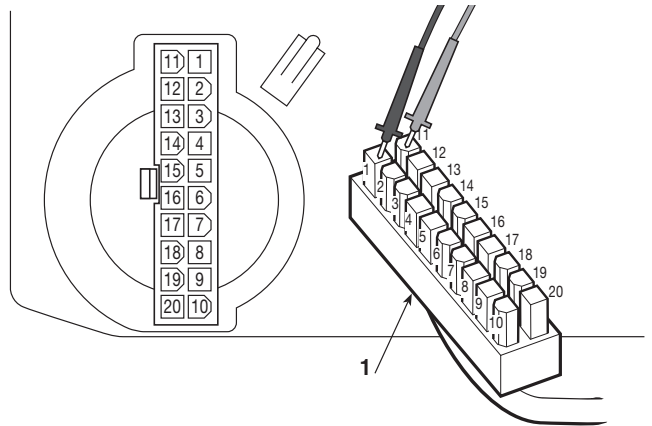

ELECTROMAGNETIC CLUTCH OPERATION CHECK



7.5
0



from 2007 to
page 1 / 1

7.5 ELECTROMAGNETIC CLUTCH OPERATION CHECK



WARNING! – This check must be made with the engine off.

Disconnect connector and bridge terminals 2 and 11 of cabling connector **(1)**.

With the key set to «ON», when the switch is operated a click must be heard from the moving part of the clutch, due to excitation of the electric wiring.

If this is not so, check the operation of the cabling and control switch [see 7.3].

The clutch must be replaced if engagement does not take place after these checks.

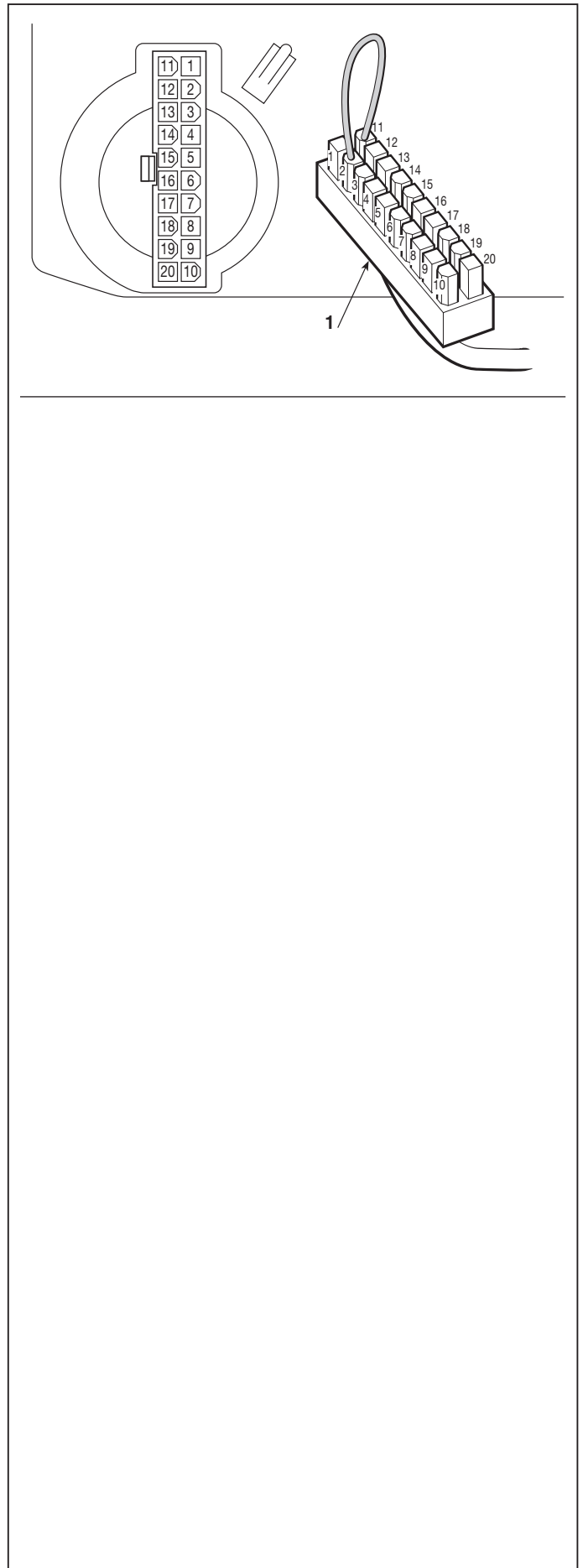

STARTER RELAY OPERATION CHECK

7.6
0

from 2007 to
page 1 / 1

7.6 STARTER RELAY OPERATION CHECK



WARNING! – Remove the cap of the sparking plug (or plugs), since the safety systems that normally prevent accidental starting of the engine are cut out when the checking procedure is carried out.

To do this requires:

- engaging the parking brake;
- disengaging the blade;
- the key in the «ON» position.

Disconnect the connector **(1)**.

In making a bridge between the terminals 11 and 4 of the wiring connector **(1)**, the click of the relay bobbin should be heard and the starter motor should come into action.

► **Only with B&S and Tecumseh engines:**

If the relay clicks but the starter motor does not go, make a bridge **(2)** with a large section cable (5 mm²) between the power contacts of the relay.

If the starter motor comes into operation, look for the fault within the relay or replace it. Otherwise, check the starter motor together with its wiring.

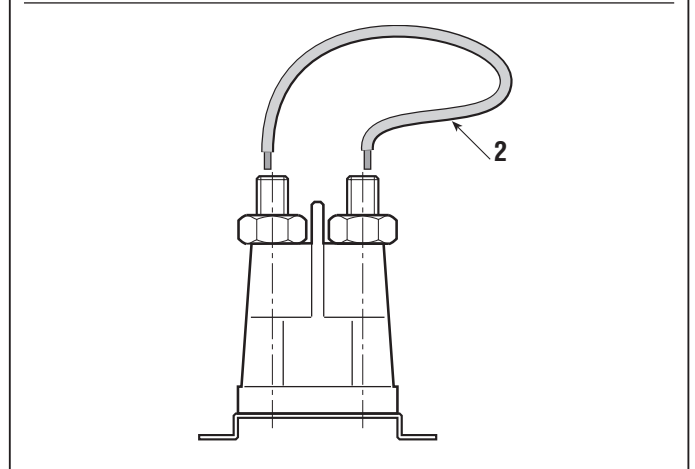
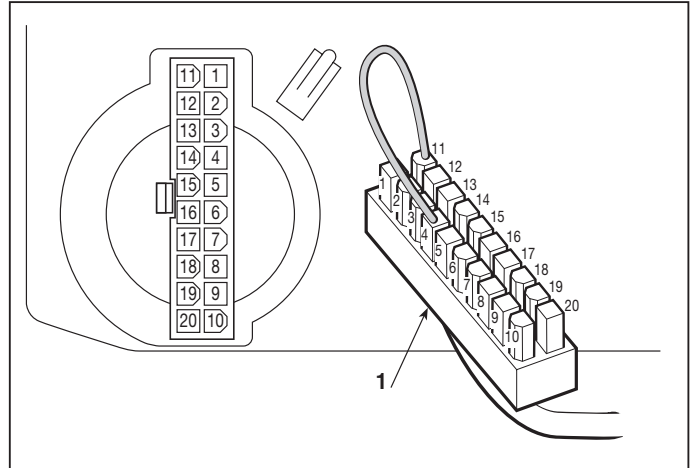

7.7 ELECTRONIC CARD OPERATION CHECK

A) Card supply

To make this test it is necessary to have:

- The key in the «ON» position
- Connector **(1)** connected to the card.

In this situation the pilot lamp should come on.

This check is done with the tester in Voltmeter function (Volt DC 0 ÷ 20), with the black ferrule on terminal 1 and the red ferrule on terminal 11 of the wiring connector **(1)**.

The reading on the tester shows the battery's voltage.

B) Safety and service supply check

To make this test it is necessary to have:

- The key in the «ON» position
- Connector **(1)** connected to the card.

This check is done with the tester in Voltmeter function (Volt DC 0 ÷ 20), with the black ferrule **to earth** and the red ferrule on terminal 10 of the wiring connector **(1)**.

C) Checking the operation of the self-setting protection

For this test, put everything in the same situation as in point "A".

By connecting terminal 10 of the connector **(1)** to the frame's earth, the pilot lamp should go out due to the protection cutting in; eliminating the connection to earth, the pilot lamp should come on again.

NOTE

During this test, the self-setting protection reaches very high temperatures (around 160 °C) which are to be considered normal. Similarly, there might be some smoke inside the transparent box which is due to the overheating of the powder inside.



WARNING! Do not touch this component of the card until it has cooled down.

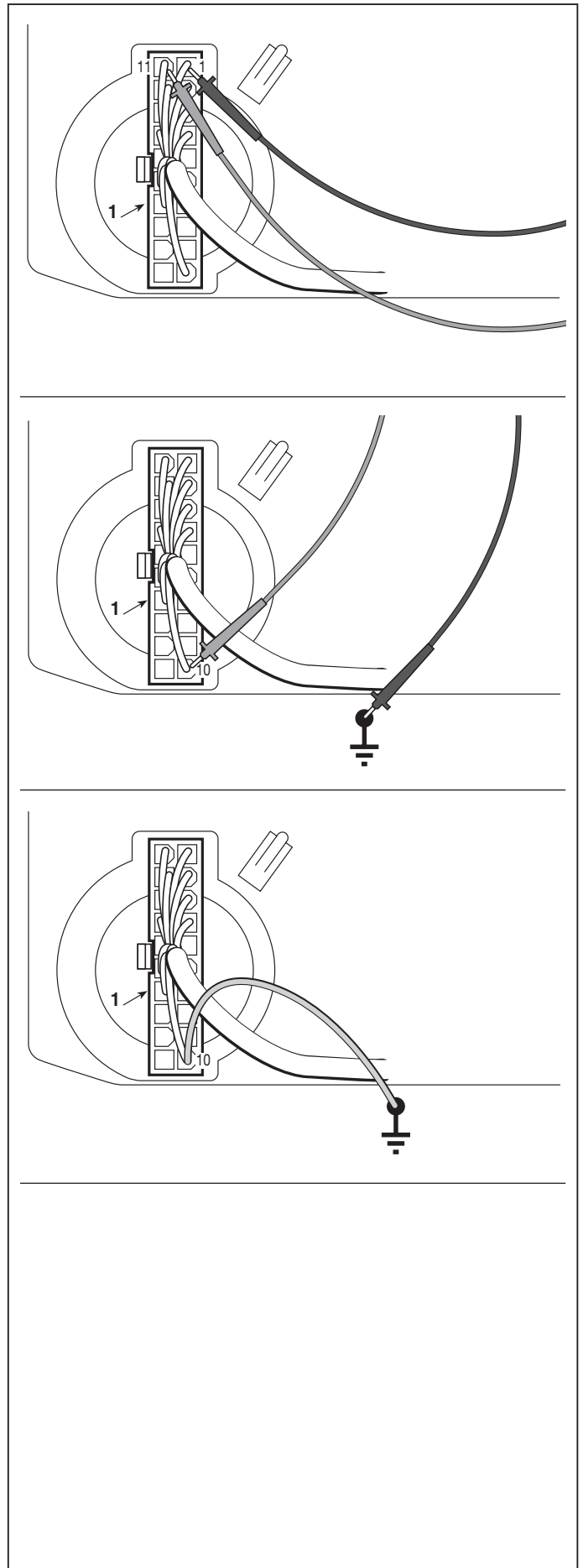

RECHARGE CIRCUIT CHECK

 7.8
0

from 2007 to

page 1 / 1

7.8 RECHARGE CIRCUIT CHECK

The job of the voltage regulator is to supply a flow of current to the battery at a constant voltage of about 14 - 15 Volts, cutting in every time that the output voltage from the generator exceeds this threshold.

A faulty regulator may recharge the battery insufficiently (therefore needing frequent recharging) or, otherwise, may supply overloading that causes the self-resetting protection to cut in.

Before checking the recharge circuit, make sure that:

- all connections are correct;
- the earth connections are firmly connected, especially the earth connections to the regulator;
- the battery is charged and not sulphated [see 7.9];
- the charger fuse is not blown.

A) Checking the lower charging limit

Start the engine and keep running at minimum (with the headlights on - ► *if fitted*).

With the voltmeter tester, measure the voltage at the battery terminals. If the value does not rise but tends to fall, even slowly, it means that the regulator is not charging sufficiently and must be replaced.

If the voltmeter shows no value it means that the charger fuse is blown.

► **Only with a Honda engine:** check the recharge relay. On moving the key from «OFF» to «ON» and vice versa, the ticking of the relay contacts should be heard; otherwise it should be replaced.

B) Checking the upper charging limit

Start the engine and take it to maximum speed. With the tester in the voltmeter function, measure the voltage at the battery terminals. The amount should rise and settle at 14-15 Volts after about 10-15 minutes.

If this level is exceeded to a point where the engine stops due to the self-resetting protection device cutting in (at about 16 Volts), it means that the regulator is charging too much and must be replaced.

7.9 CARE AND MAINTENANCE OF THE SEALED BATTERY

A) General information

In a sealed “dual” battery, the electrolyte for each element is carefully measured out during manufacture and sealed at source, in order to ensure maximum performance during the battery’s entire life.

With a battery of this type, it is not necessary to add water or acid, and the cover must never be opened or removed.

B) Recommendations for correct use

To keep the battery performing at optimum levels and to increase its life, various precautions should be taken:

- always keep the battery fully charged;
- always recharge a flat battery within 1 month, otherwise the elements could be damaged and no longer able to take the charge (sulphated);
- always recharge the battery before and after periods of prolonged inactivity or storage.

C) Rules for recharging the battery

Recharging is a particularly important operation for the life of the battery and must be carried out according to these instructions:

- do not recharge the battery when its case is broken or damaged;
- carefully read the instructions for using the battery charger and the battery;
- use the appropriate battery charger;
- recharge at a room temperature of between 10° and 30°C;
- check that the battery does not heat to beyond 50°C while recharging. If it should do so, stop recharging immediately and dispose of the battery since it will be unusable.

With the battery disconnected (and at rest for at least 12 hours) and the tester in voltmeter function, measure the voltage between the terminals. The amount given (open circuit voltage) gives an indication of the operations to be carried out, as per the following table:

Battery voltage with open circuit	Battery state	Operation to be carried out
> 12.6 Volts	Fully charged	None
< 12.4 Volts	Low charge	Recharge

Check the battery voltage at least 12-24 hours after recharging.

FITTING SAFETY MICROSWITCHES

7.10
0

from 2007 to
page 1 / 1

7.10 FITTING SAFETY MICROSWITCHES



IMPORTANT

If the microswitches are to function correctly, it is important to follow the exact assembly positions by referring to the drawings that indicate the various usages of each type.

A = Free

B = Activated

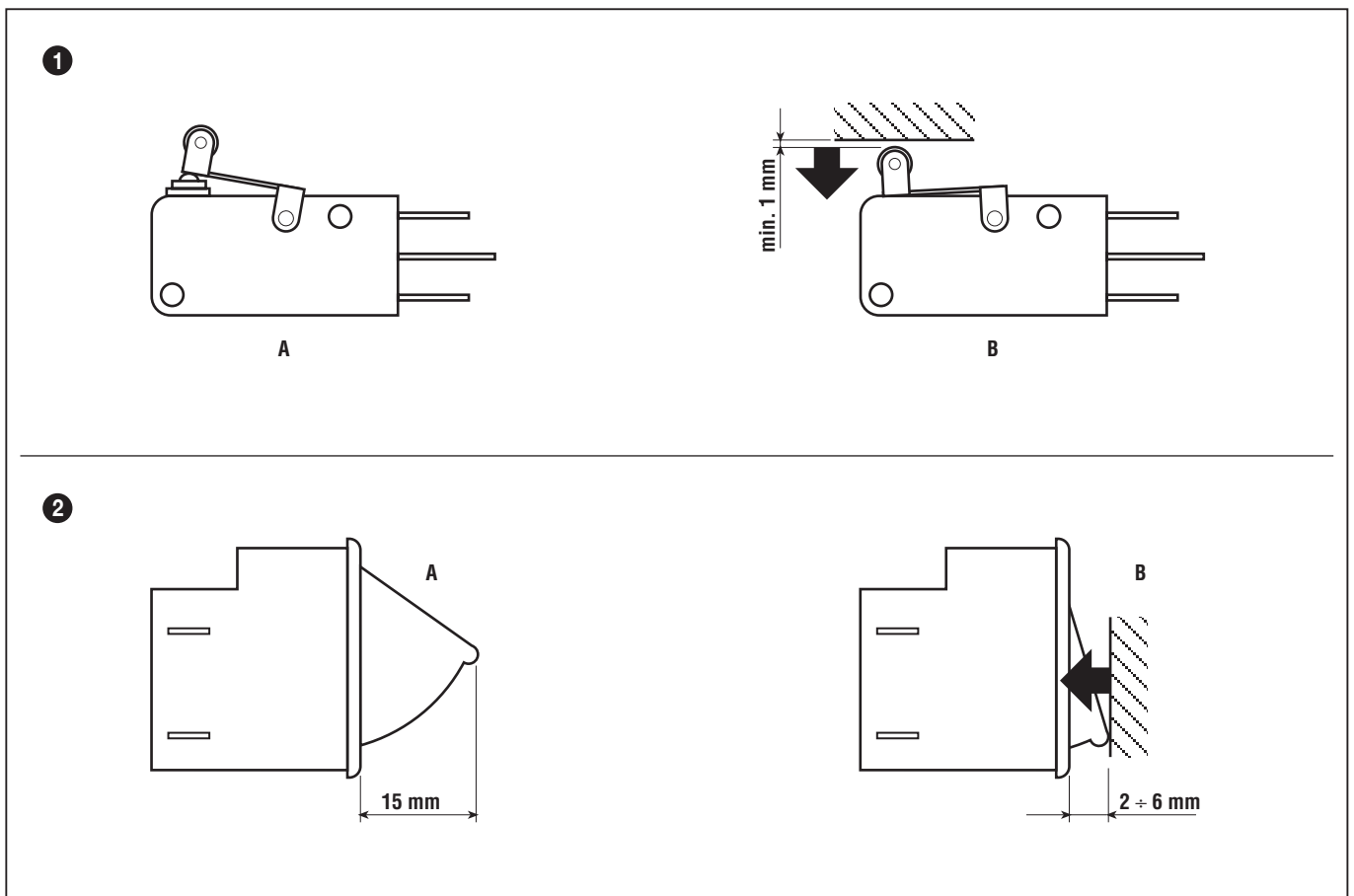

Adjust the seat safety microswitch **(1)** only by changing the position of the cam **(2)**, after loosening the two fixing screws **(3)**.

This adjustment is correct when you have checked the following:

A = seat free: the lower edge of the cam **(2)** should be touching the microswitch button without activating it.

B = seat with the driver in position: the lateral edge of the cam **(2)** should press the push-button, leaving at least 2-3 mm more travel.

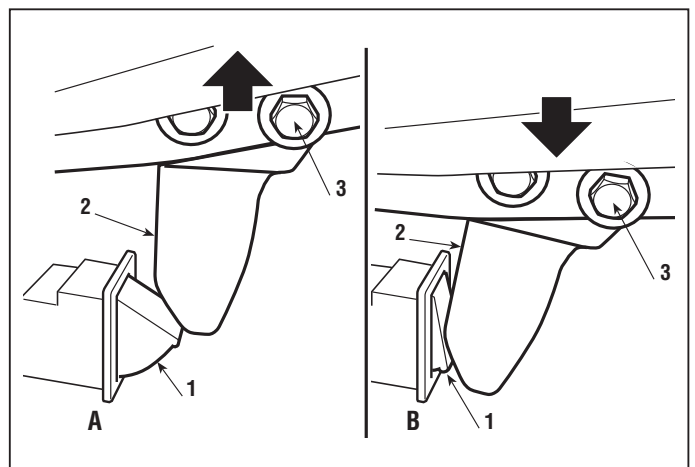

1 Engines B&S - Tecumseh - Kohler

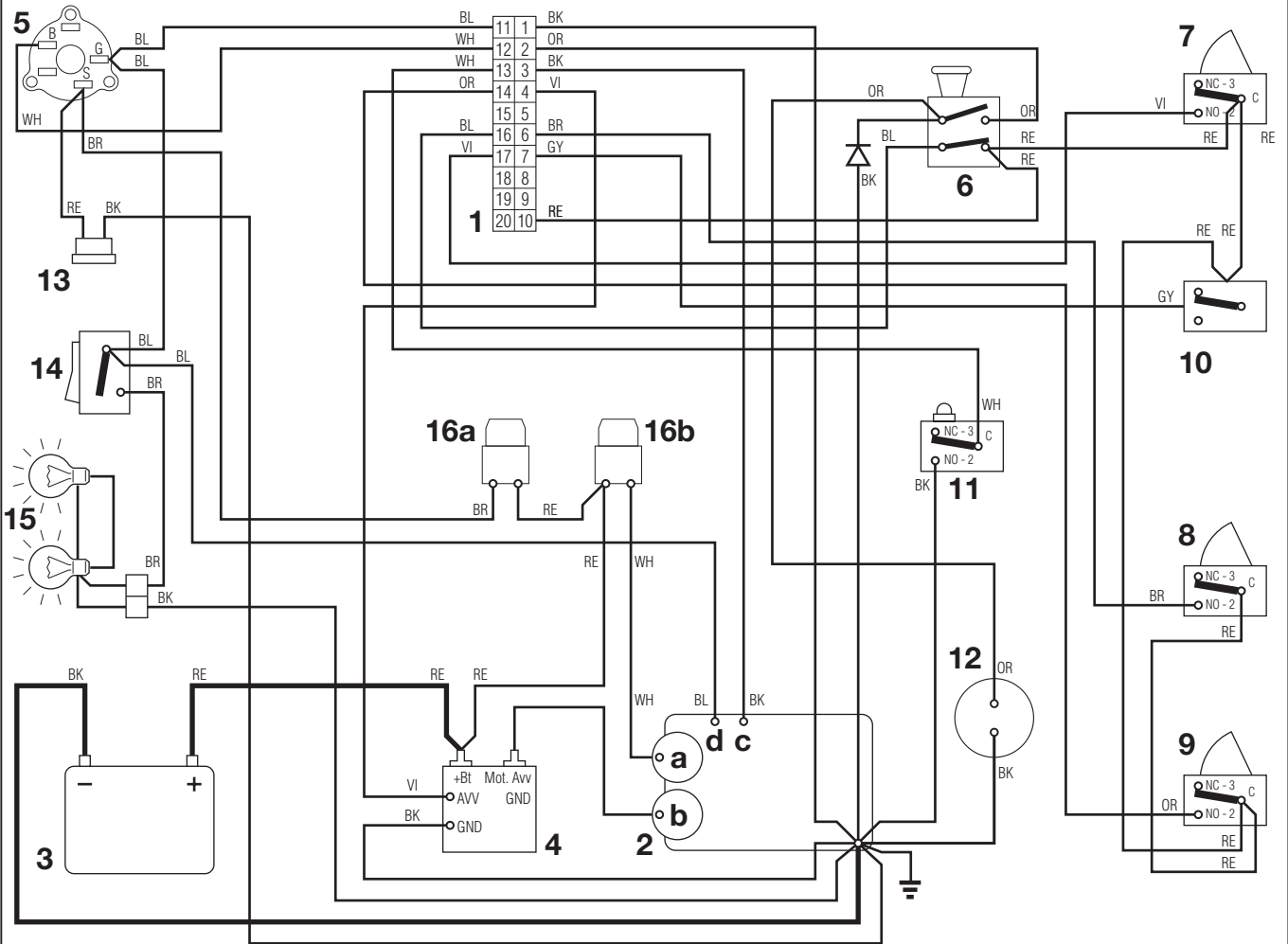

- 1 Electronic card
- 2 Engine
- 2a Generator
- 2b Starter motor
- 2c Engine stop
- 2d Carburettor
- 3 Battery
- 4 Starter relay
- 5 Key ignition switch
- 6 Blades switch
- 7 Brake microswitch
- 8 Grasscatcher microswitch
- 9 Seat microswitch
- 10 Neutral microswitch
- 11 Grasscatcher full microswitch
- 12 Clutch
- 13 Recharge connector
- 14 Headlight switch
- 15 Headlight
- 16a 10 A fuse
- 16b 25 A fuse

- CABLE COLOURS**
- BK** Black
 - BL** Blue
 - BR** Brown
 - GY** Grey
 - OR** Orange
 - RE** Red
 - VI** Violet
 - WH** White

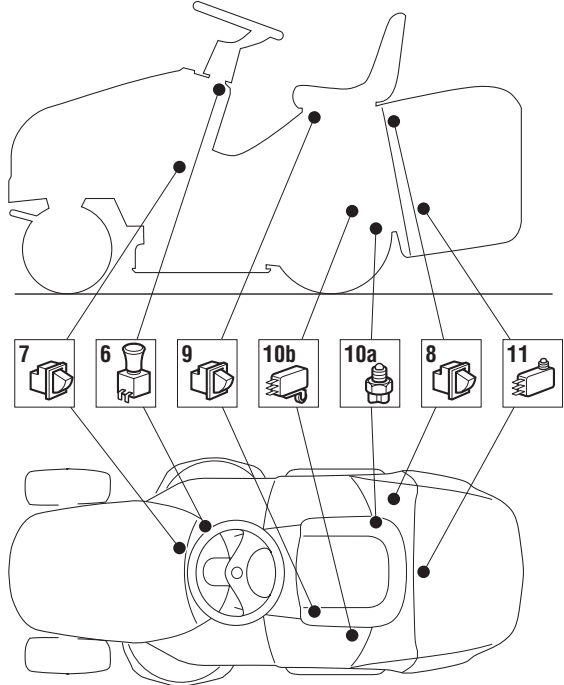

2 Engines Honda

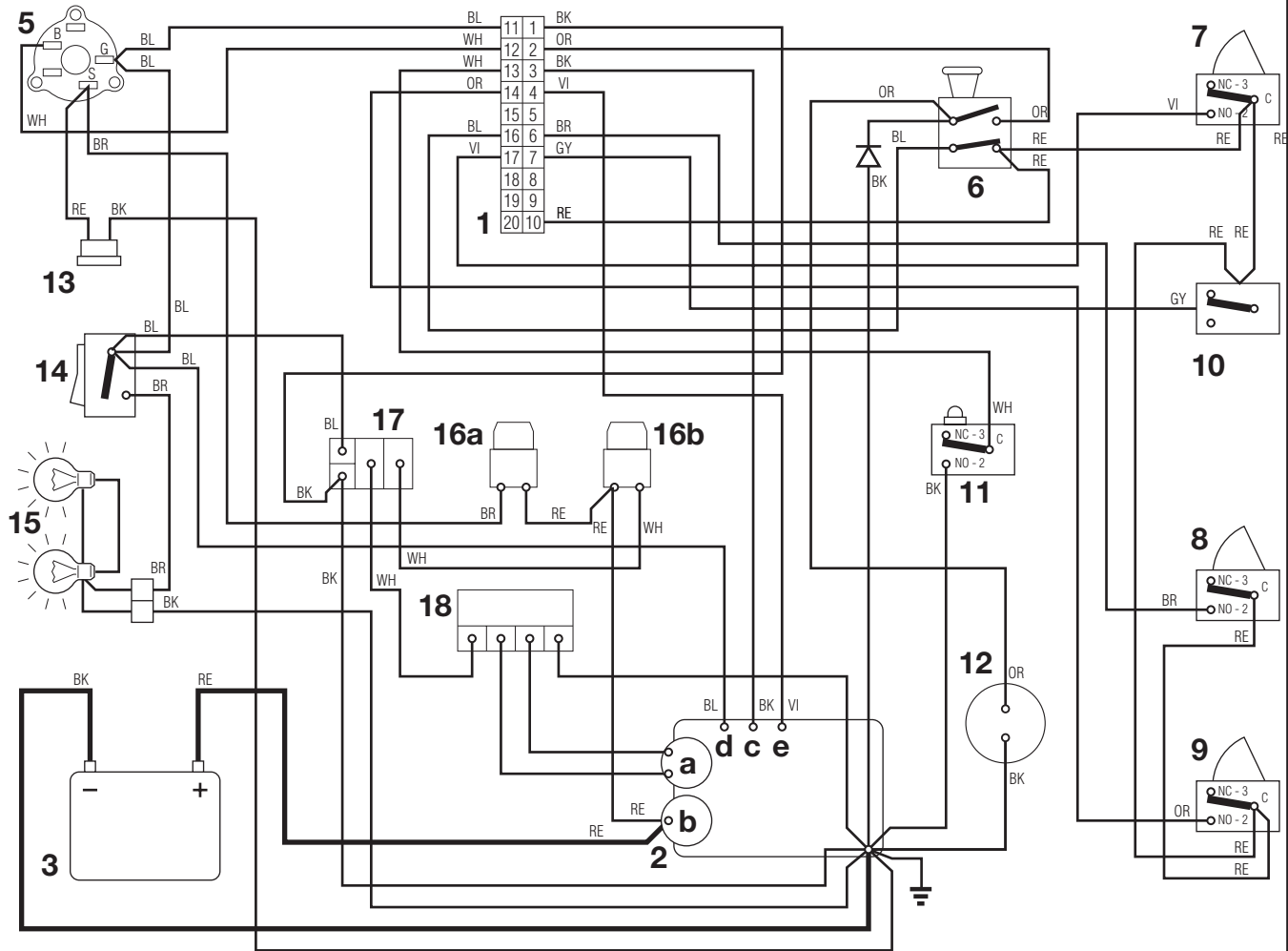

- 1 Electronic card
- 2 Engine
- 2a Generator
- 2b Starter motor
- 2c Engine stop
- 2d Carburettor
- 2e Starter relay
- 3 Battery
- 4 Starter relay
- 5 Key ignition switch
- 6 Blades switch
- 7 Brake microswitch
- 8 Grasscatcher microswitch
- 9 Seat microswitch
- 10 Neutral microswitch
- 11 Grasscatcher full microswitch
- 12 Clutch
- 13 Recharge connector
- 14 Headlight switch
- 15 Headlight
- 16a 10 A fuse
- 16b 25 A fuse
- 17 Recharge relay
- 18 Recharge regulator

- CABLE COLOURS**
- BK Black
 - BL Blue
 - BR Brown
 - GY Grey
 - OR Orange
 - RE Red
 - VI Violet
 - WH White

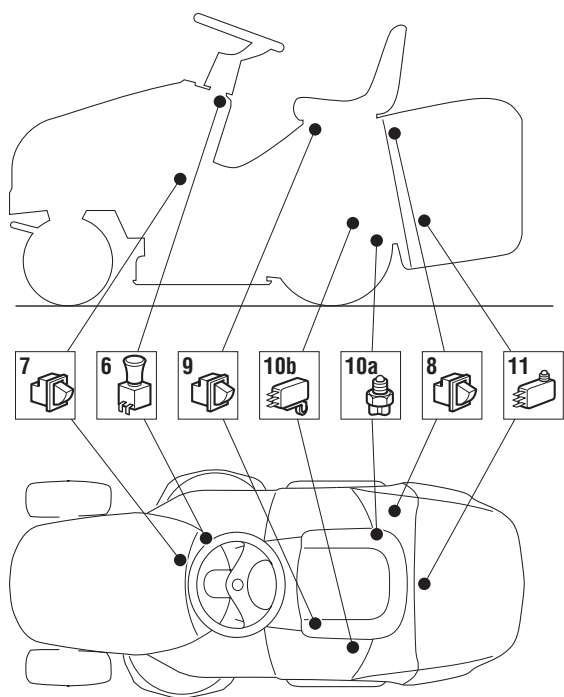

TIGHTENING TORQUES AND ADJUSTMENTS SUMMARY	◀	8.1	▶	from 2007 to
	◀	0	▶	page 1 / 1

8.1 TIGHTENING TORQUES AND ADJUSTMENTS SUMMARY

A) Tightening torques

Below are the specified tightening torques for the fixing bolts on the main parts.

- 1 Screws for engine fastening 25 ÷ 30 Nm
- 2 Screw for engine pulley 45 ÷ 50 Nm
- 3 Rear axle locknut 25 ÷ 30 Nm
- 4 Screws for blades pulleys fastening . 25 ÷ 30 Nm
- 5 Nuts for flange support 25 ÷ 30 Nm
- 6 Screw for blades 45 ÷ 50 Nm

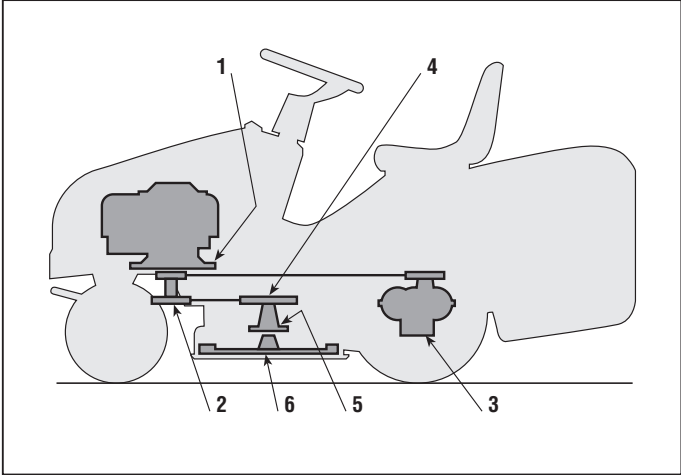

Every section in this manual gives values for all the components involved in each operation.

B) Adjustments

Operation	Position	Position of controls	Adjustment
a) Brake adjustment [see 4.2]			Peerless MST 205-531 E Dana 4360-211 43,5 - 45,5
			Tuff Torq K46S 45-47
b) Drive belt adjustment [see 4.3]			Peerless MST 205-531 E Dana 4360-211 119-121
			Tuff Torq K46S 119-121
c) Adjustment the engagement and checking thr blade brake [see 4.1]			97-99

SUMMARY OF MAIN ASSEMBLY AMOUNTS AND CHECKS

◀ **8.2**
▶ 0

from 2007 to
page 1 / 1

8.2 SUMMARY OF MAIN ASSEMBLY AMOUNTS AND CHECKS

- 1 Blades belt development
- 2 Drive belt development

