

STIGA



WORKSHOP MANUAL

ZT 5132 T
2017 - 2019



WORKSHOP MANUAL

ZT 5132 T

EDITION 2017

TABLE OF CONTENTS

1 -	INTRODUCTION.....	3
2 -	SERVICING RECOMMENDATIONS.....	8
3 -	TECHNICAL DATA	13
4 -	ENGINE AND FUEL TANK.....	15
5 -	STEERING SYSTEM - TRANSMISSION - WHEELS.....	19
6 -	CUTTING DECK	31
7 -	ELECTRICAL SYSTEM.....	39

INTRODUCTORY NOTES

The purpose of this manual is to provide a complete set of instructions related to the servicing, maintenance, disassembly, repair and installation of the mechanical components for model ZT 5132 T.

All trained Servicing personnel must use this manual during all adjustment, disassembly and troubleshooting activities.

IMPORTANT NOTE - The information contained herein is destined exclusively to the Service Centres and professional operators, with the required expertise to perform, and use the correct equipment, all the operations described, with the objective of safeguarding machine performance and safety.
The Manufacturer is under no circumstances liable for any damage or injuries due to interventions performed by private individuals or inadequate facilities.

This manual does not contemplate interventions and repair work on the engine and transmission units, as it is necessary to contact the Service Centres of the respective Manufacturers or obtain documentation supplied by the same.

The manual has left out the simplest and quickest operations that can be handled by a good mechanic, while concentrating more on specific aspects with tips and advice on the best servicing procedures.

Please take the time to read through this manual to acquire a basic understanding of the machine, which is necessary for working rationally without making errors or wasting time. All problems related to user procedures are fully covered in the User manual.

All the information provided refers to the original versions of the machines, excluding therefore interventions on machines which have been subject to modifications that have altered their characteristics or components.

All brands, names, logos and trademarks mentioned belong to their respective owners.

© by STIGA - No use of the illustrations or duplication, reproduction or translation, even partial, of the texts in this document may be made without explicit authorisation.

1 - INTRODUCTION

Summary

1.1	CONSULTATION GUIDE	3
1.1.1	Limitation of Responsibility	3
1.1.2	Structure of the Manual	3
1.1.3	Symbols and Definitions used	4
1.2	WORK SAFETY INSTRUCTIONS.....	5
1.2.1	Qualification of operators.....	5
1.2.2	Preparing to work.....	5
1.2.3	Precautions during servicing	5
1.2.4	Safety measures to be adopted.....	6
1.3	SERVICE CENTRE PROCEDURES	6
1.3.1	Machine registration	6
1.3.2	Interventions under Warranty.....	6
1.3.3	Exceptions to the use of the Warranty.....	6
1.3.4	Service repairs outside warranty.....	7
1.3.5	Fault notification	7
1.3.6	Spare parts requests	7
1.3.7	Non-original spare parts	7

1.1 CONSULTATION GUIDE

1.1.1 Limitation of Responsibility

Despite the efforts made to ensure accuracy in the realisation of this manual, errors and inaccuracies may be found in the content. The author is not responsible for any missing or incorrect information.

The Manufacturer reserves the right to make any modifications to the product without warning or any obligation to promptly update this manual.

The introduction of new procedures or indications in addition to those contained in this Manual are reported to the Service Centres by means of ad hoc bulletins and press releases.

All information contained herein is based on data available at the time of publication.

The drawings and photos included herein, may not correspond exactly to the machine on which the intervention is required.

1.1.2 Structure of the Manual

The manual is divided into chapters, paragraphs and sub-paragraphs.

- The front inside cover provides the table of contents indicating the various chapters.
- Each chapter is dedicated to a specific topic, and is preceded by an index that marks the various paragraphs contained therein.
- Each paragraph is further divided into sub-paragraphs, relative to a single procedure.

Cross-references to other parts of the manual are indicated by the symbol  [...] followed by the relevant chapter, paragraph or sub-paragraph number.

1.1.3 Symbols and Definitions used

a) Symbols

They are used to draw the attention of the operator, reminding him to perform the interventions with the necessary attention and caution.



Indicates operations that should be carried out with utmost care to avoid impairing the functionality and safety of the machine.



Indicates operations that should be carried out with utmost care to avoid injury to operators.

► Highlights all those operations that require different working methods depending on the type of machine, subsequent modifications and the accessories fitted.



Indicates cross-reference to other parts of the manual, followed by the number of the relevant chapter, paragraph or sub-paragraph.

b) Safety terminology and notes

Some paragraphs are preceded by a definition that highlights their importance:

NOTE *General reference for the correct maintenance execution and methods.*

IMPORTANT *Specific procedures or information necessary to avoid damage to the machine or equipment.*

WARNING! *Non-observance will result in the risk of injury to oneself or others.*

DANGER! *Non-observance will result in the risk of serious injury or death to oneself or others.*

c) Spatial References

Whenever reference is made to a position on the machine “front”, “back”, “left” or “right” side, this refers to the positions of the seated operator.

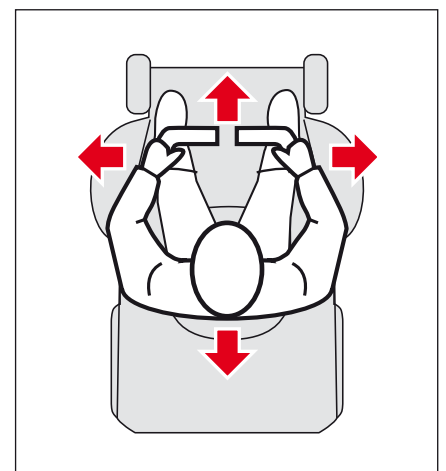

d) Abbreviations and glossary

The following abbreviations are used in this manual

Rh / Lh	= Right / Left
Min / Max	= Minimum / Maximum
Chap.	= Chapter
Par.	= Paragraph
HST	= Hydrostatic Transmission
PTO	= Power takeoff

1.2 WORK SAFETY INSTRUCTIONS

1.2.1 Qualification of operators

All maintenance, disassembly and repairs must be carried out by expert mechanics who are familiar with all the accident prevention and safety regulations after reading through the procedures in this manual.

1.2.2 Preparing to work

Before starting any work, it is very important to provide adequate preparation to achieve more efficient work. A clean work area at the beginning of each intervention makes for quicker and easier repairs.

To reduce the nuisance of having to search for tools or parts out of place, place the parts removed on a clean work surface, with all the fixing bolts arranged in their order of disassembly.

Organisation is a key element for correct reassembly. The required utensils, tools and components must be gathered before starting work.

Interrupting a job to locate tools or components is a useless waste of time.

1.2.3 Precautions during servicing

The operations described in this manual do not entail particularly hazardous situations besides the normal hazard related to mechanical operations and that can be avoided by taking the necessary care and attention normally required for this type of work.

As well as following the usual accident prevention regulations that apply to most repair shops, we recommended you:

- remove the ignition key before beginning any repair work;
- protect hands with suitable protective gloves, especially when working near the cutting unit;
- check that you do not cause accidental petrol leaks or other losses;
- do not smoke when working on the tank or when handling petrol;
- do not inhale oil or petrol fumes;
- clean up all traces of spilt petrol immediately;
- let the engine and exhaust system to cool before starting any repair or maintenance work. The engine and the exhaust system heat up considerably during operation.
- test the engine in a well-ventilated environment or where there are adequate exhaust fume extraction systems;
- do not pollute the environment with oil, petrol or other waste which has a strong impact on the environment. Dispose of all waste in accordance with the laws in force;
- ensure that other persons cannot accidentally carry out actions that may physically endanger those working on the machine.

1.2.4 Safety measures to be adopted

All the machines are manufactured in accordance with the strict European safety regulations in force. To maintain these levels of safety in the longer term, the Service Centres should work to this end by making appropriate checks every time there is the chance to do so.

In particular, every time there is work done on the machine the Service Centre should:

- check:
 - that the safety microswitches function correctly;
 - that the casings and protection covers have not been removed;
 - that the labels with instructions or provisions have not been removed or have become illegible (these form an integral part of the safety system).

- and also:
 - restore to proper working order any safety devices which have been manipulated or removed;
 - reassemble inefficient, damaged or missing casings and protection covers;
 - replace illegible labels;
 - not endorse any repair or modification on the machine or the engine which results in a change in performance or use that is incorrect or different from the purpose for which it was designed and approved;
 - warn the Customer that failure to comply with the above points automatically voids the warranty and the responsibility of the Manufacturer.

1.3 SERVICE CENTRE PROCEDURES

1.3.1 Machine registration

The Warranty registration card must be completed, signed and returned at the time of purchase. This activates the warranty card.

Claims that meet the requirements will be honoured during the limited warranty period.

1.3.2 Interventions under Warranty

The Manufacturer acknowledges the interventions performed under warranty as per the terms, procedures and limits stated in the contract.

As far as the engine and the transmission unit are concerned, the conditions provided by their respective Manufacturers apply.

1.3.3 Exceptions to the use of the Warranty

- The warranty does not cover damages caused by:
 - Lack of knowledge and familiarisation of the accompanying documentation on the part of the user.
 - Carelessness.
 - Incorrect or prohibited use or assembly.
 - Use of non-genuine spare parts.
 - Use of accessories not supplied or approved by the manufacturer.

- Furthermore, this warranty does not apply to:
 - Components subject to wear such as blades, belts, wheels, batteries and cables.
 - Normal wear and tear due to use.
 - Engine and transmission. These components are covered by the warranties of the respective manufacturers, with terms and conditions specified separately.

The purchaser is covered by national legislation of the Country he resides in. The legal rights of the laws that refer to the purchaser are not limited by this product warranty.

1.3.4 Service repairs outside warranty

The Service Centre has to make out a report containing the machine serial number, a summary of the problems, the repairs carried out and any spare parts used for each repair done on the machine.

A copy of these reports must be retained and made available to the Manufacturer together with the replaced parts in case of any subsequent disputes with Customers.

1.3.5 Fault notification

The Manufacturer welcomes any notifications of faults that recur with particular frequency. It gives the opportunity for a careful inspection of the problem and the implementation of corrective action at production level.

Similarly, the Manufacturer will report any faults discovered on the machines produced, with recommendations for the most suitable procedures for their remedy.

1.3.6 Spare parts requests

When requesting spare parts, the code number must be given, referring to the exploded charts for the year of manufacture, shown on the product identification label.

1.3.7 Non-original spare parts

Use original spare parts only. Replacement of any machine component with anything other than a part authorised by the Manufacturer can adversely affect performance, working life or safety of this machine and will void the Warranty.

The manufacturer disclaims all liability for any claims or damages, albeit under warranty, property damage, personal injury or death resulting from the use of unauthorised spare parts.

2 - SERVICING RECOMMENDATIONS

Summary

2.1	IDENTIFICATION OF THE MACHINE AND COMPONENTS	8
2.1.1	Machine identification.....	8
2.1.2	Engine identification	8
2.1.3	Transmission Unit identification	9
2.2	EQUIPMENT REQUIRED.....	9
2.2.1	Basic equipment.....	9
2.2.2	Special equipment.....	9
2.2.3	Screwing and torque tightening tools.....	9
2.3	TRANSPORTATION AND HANDLING	10
2.3.1	Machine transportation.....	10
2.3.2	Front lifting.....	10
2.3.3	Rear lifting	10
2.4	MAINTENANCE	11
2.4.1	Criteria for maintenance	11
2.4.2	Routine maintenance schedules	11
2.4.3	Control of safety devices	12

2.1 IDENTIFICATION OF THE MACHINE AND COMPONENTS

2.1.1 Machine identification

Each machine has a label (1) which shows the technical specifications, the model and the serial number.

The model and serial number must be shown on each repair sheet when requests are made under Warranty, and are indispensable for spare part orders.



2.1.2 Engine identification

The engine is made to precise technical specifications which differentiate it from similar items by this same Manufacturer.

The engine has a serial number that clearly identifies the product and its specifications; this number must always be quoted when requesting spare parts or any information from the Manufacturer.



2.1.3 Transmission Unit identification

The machine is equipped with two transmission hydrostatic units.

These units are made by another manufacturer according to precise technical specifications which differentiate them from similar items by this same Manufacturer.

The transmission units have a serial number (see transmission manual) that clearly identifies the product and its specifications; this number must always be quoted when requesting spare parts or any information from the Manufacturer.



2.2 EQUIPMENT REQUIRED

2.2.1 Basic equipment

All the operations can be carried out with the tools normally available at any good motoring Servicing Centre.

The availability of an adequate lifting platform for the weight and dimensions of the machine makes it more practical to perform the interventions in the lower area of the machine.

2.2.2 Special equipment

No special tools or equipment are required to perform standard servicing operations.

However, in order to facilitate checking the alignment of the blades, it is recommended to use to use an instrument to measure the height from the ground (1) or extensible abutments (2).

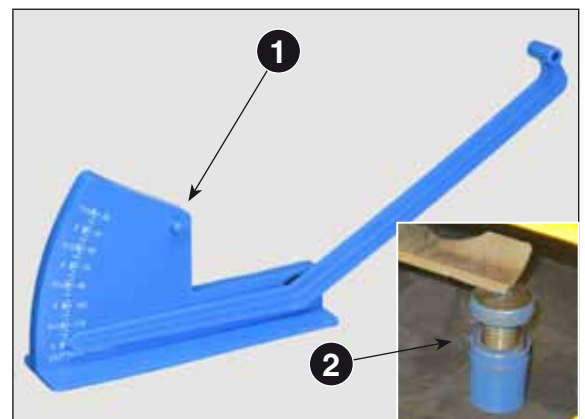

2.2.3 Screwing and torque tightening tools

The screws and nuts used on this machine are measured in inches. This entails the need to have specific wrenches and spanner sockets for screwing operations because, if the same tools foreseen for the metric screws were used, these could damage the element to be screwed and make it difficult to comply with the tightening torques provided by the Manufacturer.

The table shows the measurements of the screws and nuts used on the machine, with the indication of the correct wrench to use and the tightening torque foreseen for standard screwing (Grade 2) and for the screwing of parts subject to heavy loads (Grade 8).

Hexagonal head screws and nuts						
UNC Thread Ø		1/4-20	5/16-18	3/8-16	7/16-14	1/2-13
Key		7/16"	1/2"	9/16"	5/8"	3/4"
Torque (grade 2)	Nm	7	15	27	40	69
Torque (grade 8)	Nm	16	35	62	97	152
Hexagonal Allen grub screws						
UNC Thread Ø		1/4-20	5/16-18	3/8-16	7/16-14	1/2-13
Key		3/16"	1/4"	5/16"	3/8"	3/8"
Torque (grade 2)	Nm	7	15	27	40	69
Torque (grade 8)	Nm	16	35	62	97	152

Special tightening torques are indicated in the manual in the description of the specific procedures.

2.3 TRANSPORTATION AND HANDLING

2.3.1 Machine transportation

Pay utmost attention when loading the machine on or off a trailer or truck.

- Use the machine chassis to fasten it to the means of transport
- NEVER fasten it to bars or joints that could get damaged.
- DO NOT transport the machine with the equipment (if any) in the raised position.

2.3.2 Front lifting

Engage the parking brake to block the rear wheels and prevent any uncontrolled movement of the machine. Position a jack (1) under the front end of the footplate (2) and lift it enough to insert two stands (3) under the support arm (4) on the front wheels.

Release the jack and make sure the machine is stable before starting any work.

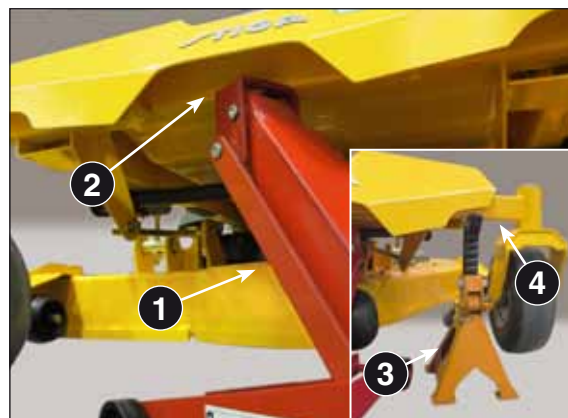

2.3.3 Rear lifting

Position two suitably sized wedges in front of the front wheels to prevent all uncontrolled movement of the machine.

Position a jack (1) in the centre of the rear beam of the chassis (2) and lift it enough to insert two stands (3) on both sides of the chassis.

Release the jack and make sure the machine is stable before starting any work.

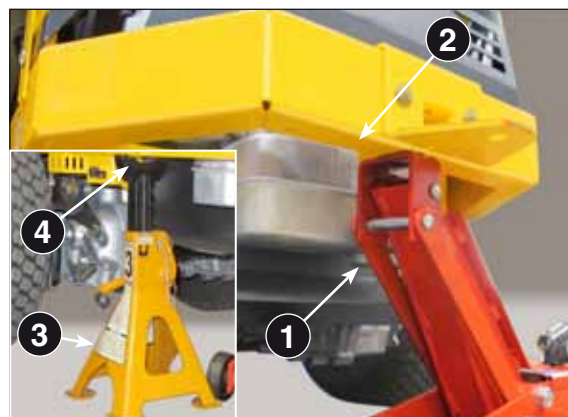











2.4 MAINTENANCE

2.4.1 Criteria for maintenance

The Instruction Handbook has a number of operations to be carried out by the Customer for a minimum of basic maintenance, and other operations not always within his capacity. For this reason the Service Centre should undertake to keep the machine in perfect working order adopting a routine maintenance schedule.

2.4.2 Routine maintenance schedules

The routine maintenance schedule includes a series of interventions, at the intervals indicated in the table below:

INTERVAL	OPERATION	ACTION
Every 25 hours or seasonally	Check the safety systems	 DANGER! <i>Failure of the safety lock system and incorrect operation of the machine can result in death or serious injury.</i> Check that the safety systems are working correctly as indicated.  7.1.2
	Check and adjust the parking brake	Apply the parking brake and engage the transmission bypass lever. Push the machine and, if it moves, adjust the parking brake accordingly.  5.2.1
	Cleaning the machine	Clean the machine (seat, cutting deck, etc. removing all dirt and debris). Do not use high pressure washers, solvents, aggressive detergents or abrasive cleaners. Restore damaged paint using STIGA paint
	Check the tyres	See the technical specifications  3.1
	Check and sharpen the cutting deck blades	Check that the blades are not worn or damaged. Sharpen and balance the blades.  6.2.5
	Check the battery	Keep the battery terminals and the battery itself clean at all times  7.2.2
	Machine lubrication	1) Apply grease to each front wheel greaser  5.3.2 2) Apply grease to the seat adjustment system, through the fissures on the underside of the driver seat plate. Distribute the grease in the mechanism by sliding the seat backwards and forwards several times.
Every 50 hours or seasonally	Check the fixing elements	Check the blades  6.2.4, the assembly nuts and bolts and the other fixing elements. Replace all missing or damaged fixing elements. Tighten the screws and nuts to the correct torque.  2.2.3
	Check the muffler and spark guard	Replace the muffler and (if present) the spark guard if there are signs of corrosion.
Every 100 hours or seasonally	Check the belts	Replace worn or deteriorated belts. Check the drive belt.  5.2.4 Check the blade control belt.  6.3.1

2.4.3 Control of safety devices

It is of utmost importance that all the safety systems present upon delivery of the machine are kept in efficient working order over time, conducting appropriate checks every time there is the chance to do so. The machine safety system includes:

a) Electric safety devices

 Always check the operation of the safety microswitches, simulating various situations of use as indicated in the specific chapter [\[7.1.2\]](#).

b) Safety labels and symbols

 These labels are considered an integral part of the safety devices. Always replace illegible and missing labels, as shown in the layout below.

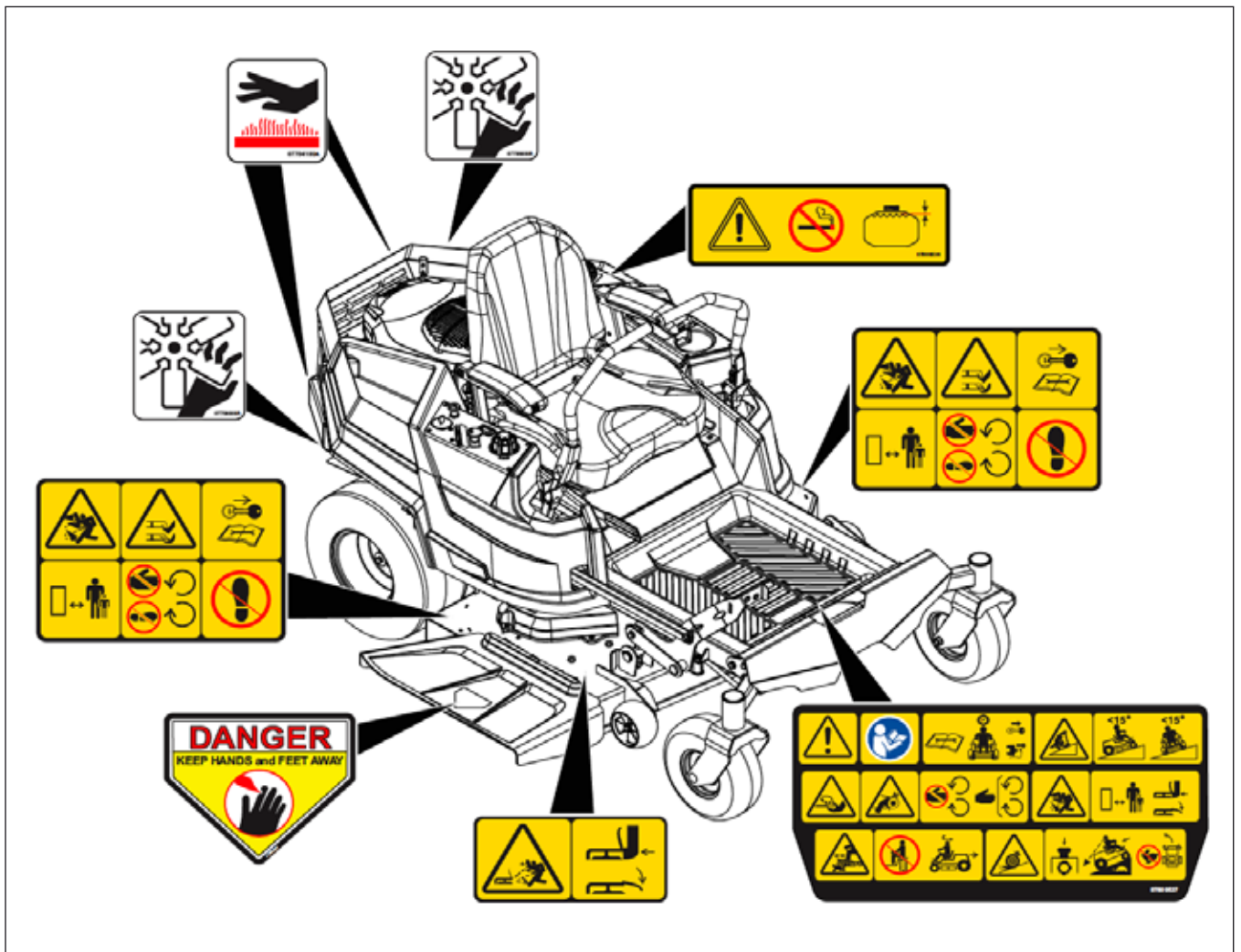

3 - TECHNICAL DATA

Summary

3.1	TECHNICAL SPECIFICATIONS	13
3.2	OVERALL DIMENSIONS	14

3.1 TECHNICAL SPECIFICATIONS

	Machine Model	Stiga ZT 5132 T
General Information	Dimensions (Length x Width x Height) (mm)	1969 x 1610 x 1039
	Machine weight (Kg)	279
Engine and Fuel tank	Engine Brand and Model	Kawasaki FR691V 726 cc
	Power and Engine Speed	16.5 kw @ 3150
	Tank capacity (litres)	10.5
Electrical system	Voltage	12V
	Battery	12 Ah - 190 CCA
Transmission	Transmission units brand and model	N.2 Hydro-Gear® EZT 2200 (1 Rh + 1 Lh)
	Maximum forward speed (km/h)	11.3
	Maximum reverse speed (km/h)	4.8
	Control belt	Trapezoidal belt section HA unwrapped
Wheels and Tyres	Front (Tubeless)	11 x 4-5
	Rear (Tubeless)	18 x 8.5-8
	Front tyre pressure (kPa)	3 bar
	Front tyre pressure (kPa)	0.7 bar
Cutting means	Cutting width (cm)	1321
	Number of blades	3
	Number of cutting heights	13
	Minimum cutting height (mm)	38
	Maximum cutting height (mm)	114
	Control belt	Trapezoidal belt section HA wrapped

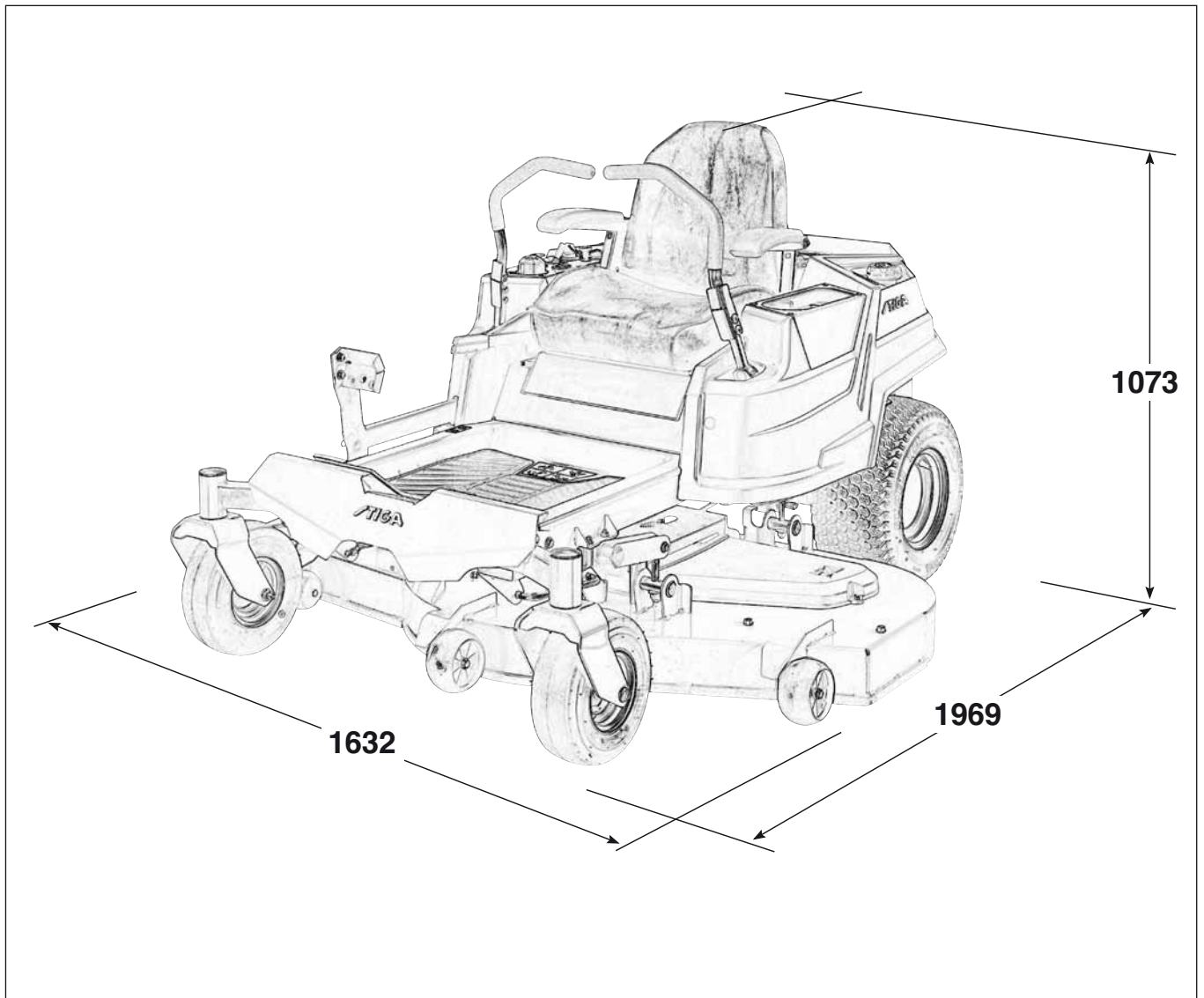
3.2 OVERALL DIMENSIONS

4 - ENGINE AND FUEL TANK

Summary

4.1	ENGINE	15
4.1.1	Engine tuning and maintenance	15
4.1.2	Removal of the engine	15
4.2	TANK	17
4.2.1	Preliminary procedures.....	17
4.2.2	Removal of the fuel tank.....	18

4.1 ENGINE

4.1.1 Engine tuning and maintenance

Kindly refer to the Manuals and the Technical Documentation supplied by the Manufacturer for information on all interventions on the engine, such as adjustments, maintenance, removal and replacement of components.

If in doubt of for any further assistance, please contact the Manufacturer or an authorised Service Centre.

4.1.2 Removal of the engine

- Follow steps 1 to 5 of the "Replacing the drive belt" procedure [5.2.4].

1. **FIRST** disconnect the black ground cable from the battery, and **THEN** the red cable, to prevent possible short circuits and dangerous situations.

2. Disconnect the fuel delivery pipe, taking care not to spill fuel.

3. Remove all engine connections:

- the accelerator cable;
- the choke cable;
- the cabling connector;
- the starter motor connector;
- the ground cables;
- the venting tube.

4. Measure the projecting part of the pin (1) in relation to the nut (2), then loosen the nut (2) and release the tensioner spring (3).

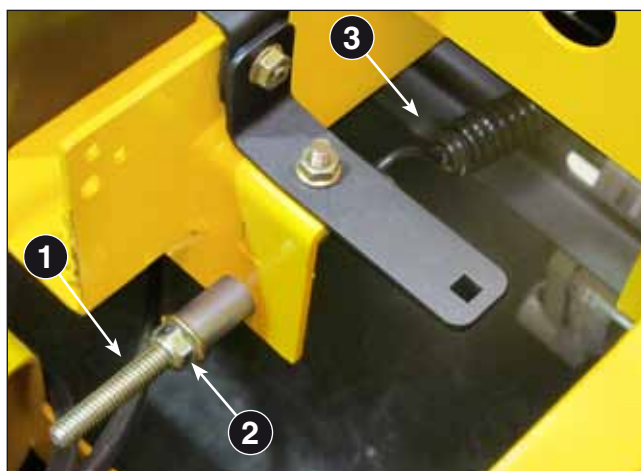

5. Move the tensioner arm to the left (4) and free the belt (5).

6. Remove the shaft with the pulley (6).

Identify and undo the screws (7) that fasten the engine to the chassis, then carefully lift and remove the engine using equipment suitable for the weight of the engine (about 45-50 kg) and the designated lifting points to guarantee safe working conditions.

NOTE *If the engine must be replaced with a new one, retain the accessories and fasteners that may not be included in the new engine supplied.*

To reassemble, follow the operations described above in the reverse order, taking care to:

- make sure that the pin (8) is correctly inserted into the hole of the reaction arm (9).
- to start with, manually tighten the engine fastening screws by 3-4 turns, then fully tighten to a torque of 31-34 Nm;
- tighten the clutch fastening screws to a torque of 43-64 Nm;
- reinstate the tension of the tensioner spring (3) returning the threaded protrusion of the pin to the previously detected value (approx. 61 mm).
- carefully reinstate all electric connections;
- reconnect the fuel pipe, making sure there are no leaks;

After reconnecting the choke (10) and the accelerator (11) cables, check that the minimum and maximum engine speeds conform to the Manufacturer's requirements.

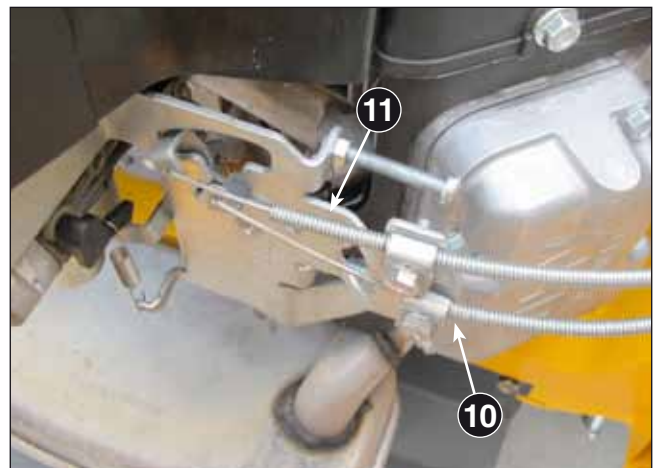
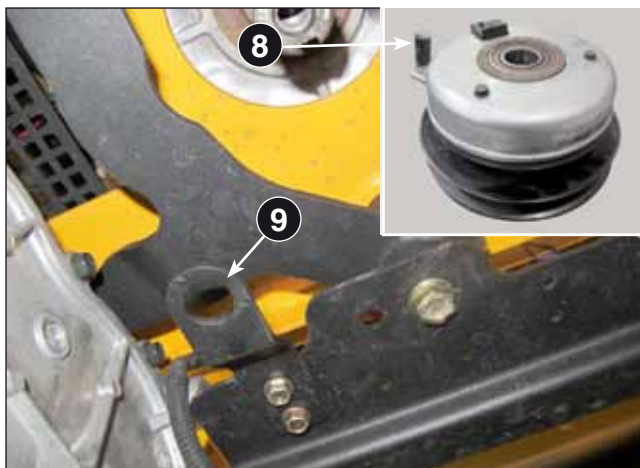
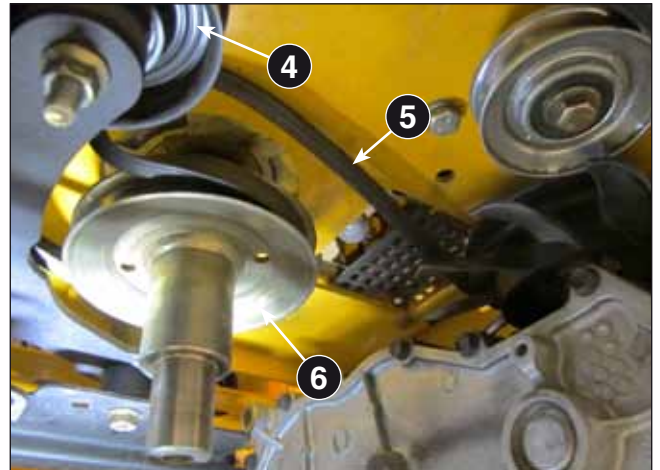

4.2 TANK

4.2.1 Preliminary procedures

It is only necessary to remove the fuel tank when replacing it, and to do so requires the removal of certain elements of the unit beforehand.

1. Unscrew the tank cap (1), disconnect the cap (1) clip (2) and fasten the wire (3) to the nozzle (4) to prevent it falling inside.



2. Remove the left cover of the chassis (5) fixed by:

- two screws (6) accessible from the front lower section;



- one screw (7) fixing the rear section in place;



- one screw (8) found inside the wheel compartment;
- one screw (9) and nut (10) found at the bottom.

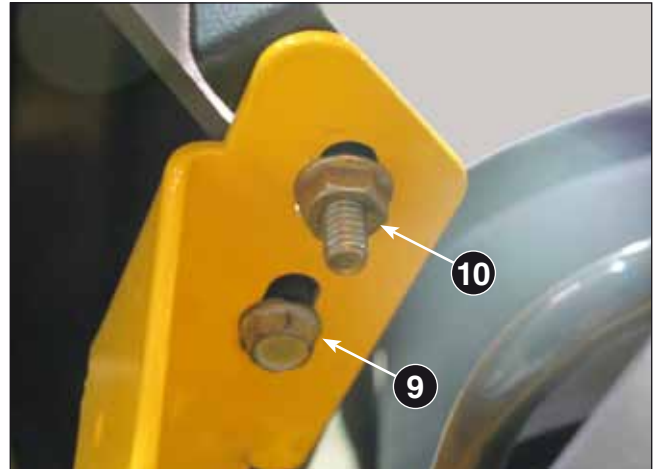
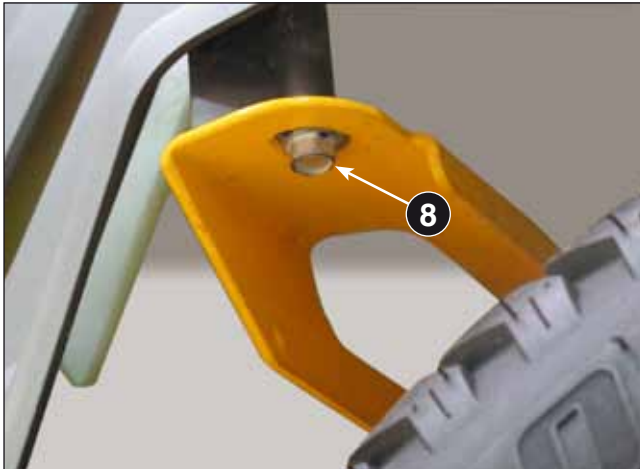



4.2.2 Removal of the fuel tank.

 Completely empty the fuel, taking care not to disperse it in the work area.

1. Remove the clamp (1) disconnect the petrol pipe (2) and the venting tube (3)
2. Grasp the tank (4) and extract it from its seat.

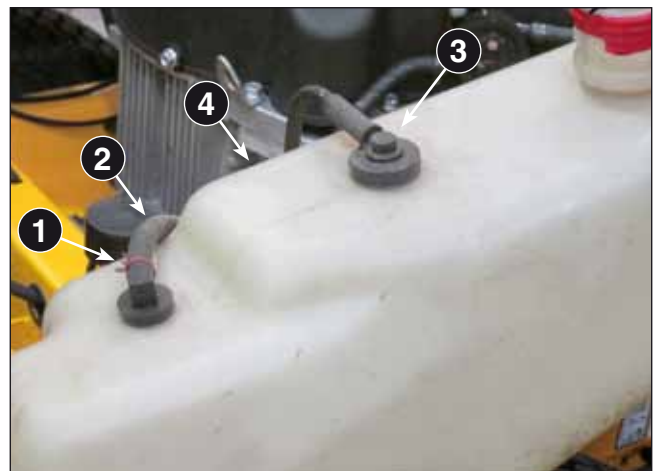
Complete the reassembly process, following the steps described above in the reverse order.



 Reconnect the fuel pipe (2), and the clamp (1) making sure there are no leaks.

5 - STEERING SYSTEM - TRANSMISSION - WHEELS

Summary

5.1 STEERING SYSTEM (DIRECTION OF TRAVEL)	19
5.1.1 General information	19
5.1.2 Ergonomic adjustment of the levers.....	19
5.1.3 Adjusting the direction of travel.....	20
5.2 TRANSMISSION	21
5.2.1 Adjusting the “neutral” system and parking brake	21
5.2.2 Adjusting maximum operating speed.....	24
5.2.3 Replacing the shock absorber	24
5.2.4 Replacing the transmission belt.....	25
5.2.5 Removing the transmission units	26
5.3 WHEELS AND TYRES	29
5.3.1 Removing and replacing the rear wheels	29
5.3.2 Replacing the front wheels	29
5.3.3 Replacing the front wheels pin bearings	30
5.3.4 Replacement and repair of tyres	30

5.1 STEERING SYSTEM (DIRECTION OF TRAVEL)

5.1.1 General information

This machine is characterised by the presence of two independent transmission units that, each controlled by a lever, control the two rear wheels in a differentiated manner.

The differentiation of the speed between the two drive wheels allows the driver to change direction, as well as the possibility to rotate the machine by 360 degrees, particularly useful in many conditions.

To achieve smooth driving of the machine, it is necessary that the two independent levers making up the handlebars are properly adjusted using two different criteria:

- **Ergonomic adjustment** = for adaptation to the physique of the driver and mechanical alignment between the two levers [👉 5.1.2].
- **Adjusting the direction of travel** = to obtain a straight forward movement of the machine with the two levers aligned with each other [👉 5.1.3].

5.1.2 Ergonomic adjustment of the levers

a) Adjustment of the height and the longitudinal position

1. Undo the two nuts (1) and move the lever (2) to the desired height, using two of the three holes provided on the control arm (3).

WARNING! *The lever must always be fixed by two screws.*

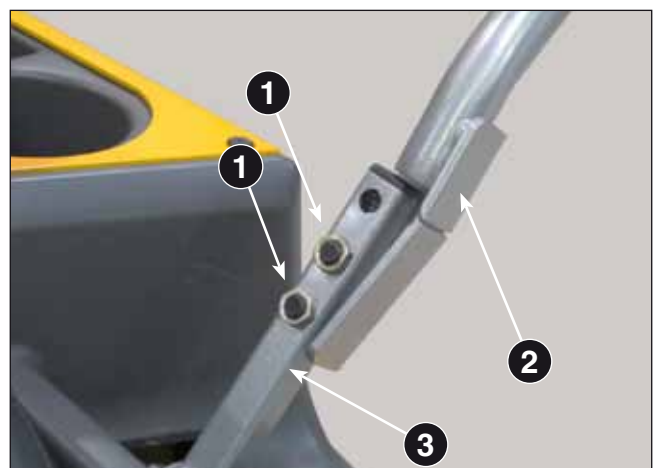

2. Before tightening the nuts, move the lever (2) forwards or backwards, until the desired distance is reached in relation to the seat.
3. Fully tighten the nuts (1).

NOTE Tighten the upper screw first.

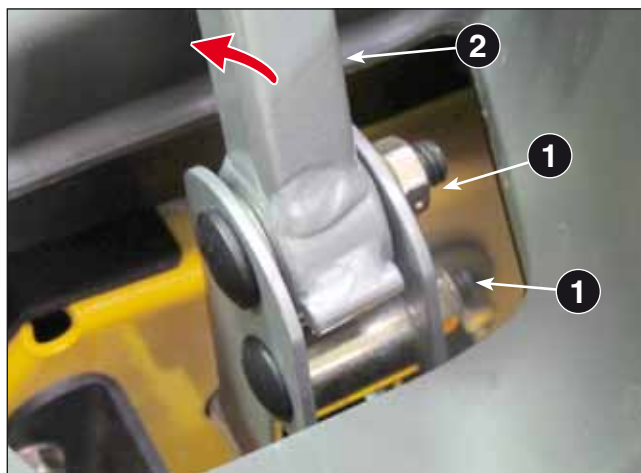

NOTE - When the adjustment has been completed, the two handgrips must be aligned with each other.

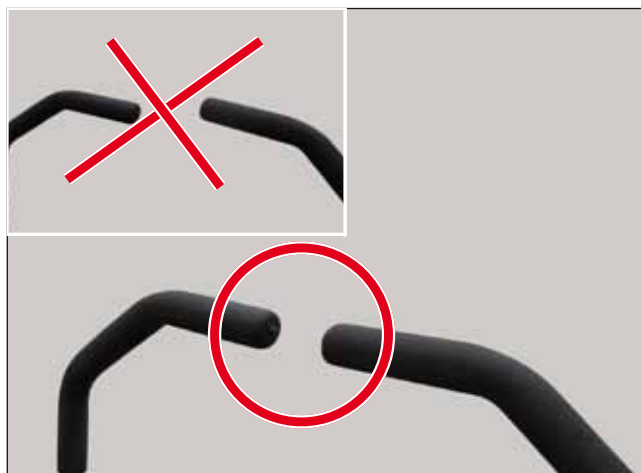

b) Adjusting the distance between the levers

1. Loosen the nuts (1) and rotate the eccentric screw (2) until the desired distance between the levers is reached, when returned to the working position.
2. Fully tighten the nuts (1).

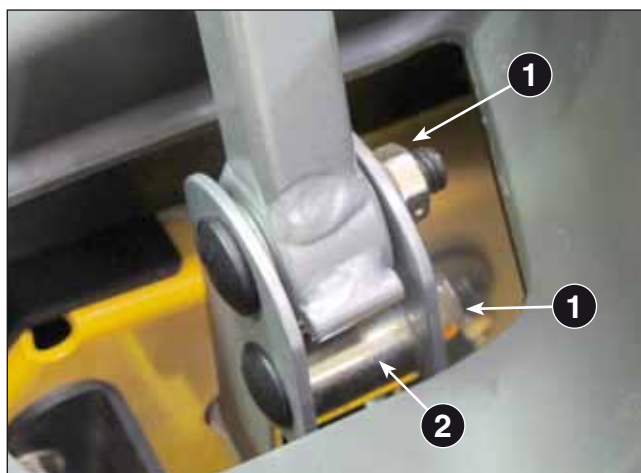

5.1.3 Adjusting the direction of travel

The stroke of the steering levers may require adjustment if the machine tends to deviate from its trajectory towards the right or left when both steering levers are pushed fully forward, at maximum speed.

The displacement of the machine should not exceed 60 cm after travelling for 9 metres.

If there is any sideways displacement of the machine, this means that the drive wheel on that side is turning slower than the opposite drive wheel.

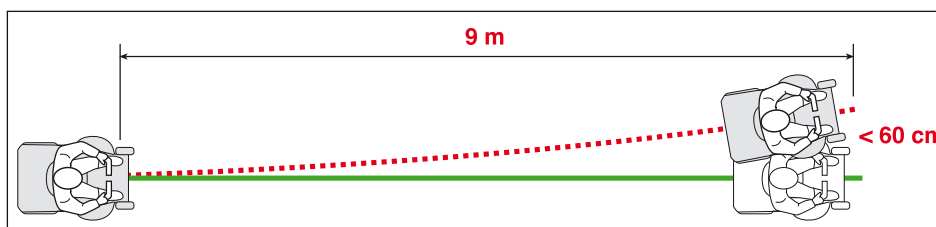

To allow the machine to travel in a straight line in a forward direction, it is necessary to decelerate the faster wheel or accelerate the slower one.

NOTE– *This adjustment can only be performed in forward gear.*

IMPORTANT - *Check the pressure of the rear tyres before making any adjustments. Incorrect or unequal pressure of the tyres can cause displacements in the direction of travel.*

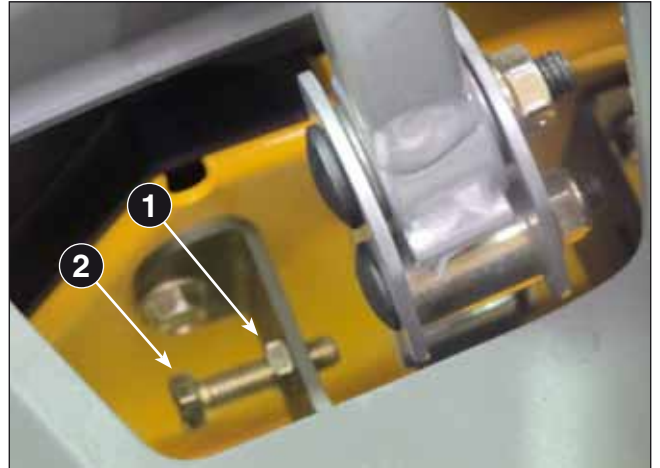

1. Determine in which direction the displacement occurs.
2. Loosen the lock nut (1) on the adjusting screw (2) on the affected side.
3. Adjust the speed:
 - Turning the screw (2) clockwise to decrease the speed of the corresponding wheel.
 - Turning it counter clockwise to increase the speed of the corresponding wheel.
4. Tighten the lock nut (1).

If, after this adjustment, the lever handles are not aligned with each other, proceed with the alignment adjustment [👉 5.1.2a].

5.2 TRANSMISSION

5.2.1 Adjusting the “neutral” system and parking brake

The "neutral" return mechanism on the transaxle is designed to move the command to a "neutral" position when the operator lets go of the controls.

Follow the procedures illustrated below to adjust the “neutral” return mechanism on the transaxle.

IMPORTANT - *Always perform the adjustment on both transmission units.*

- Lift the rear part of the machine [👉 2.3.3].
- Disassemble the rear wheels [👉 5.3.1].

B) Adjusting the “neutral” position

1. Remove the guard (1) fixed by the screws (2) and (3).
2. Release the split pin (4) and washer (5) and disconnect the parking brake rod (6).
3. Remove the starter cable (7) from the control lever.
4. Start the engine and take the accelerator to maximum speed.
5. Check the axle rotation. If the axle does not rotate, proceed to Step 6. If the axle does rotate, proceed to Step 7.
6. Stop the engine and reconnect the rod (7) and adjust the mechanical linkage of the machine.
7. Observe the direction of the axle rotation. Switch the engine off. Loosen the adjuster screw (8) so that it is possible to rotate the control arm (9). Rotate the control arm in the opposite direction to the axle rotation with small 5° increases until the axle comes to a halt.
8. Tighten the adjuster screw (8) to a torque of 20 Nm. Repeat the control as specified in steps 4 and 5.
9. Engage and disengage the parking brake and make sure that the pin (10) enters the slot correctly (11); if this is not the case, follow the instructions indicated in paragraph b).

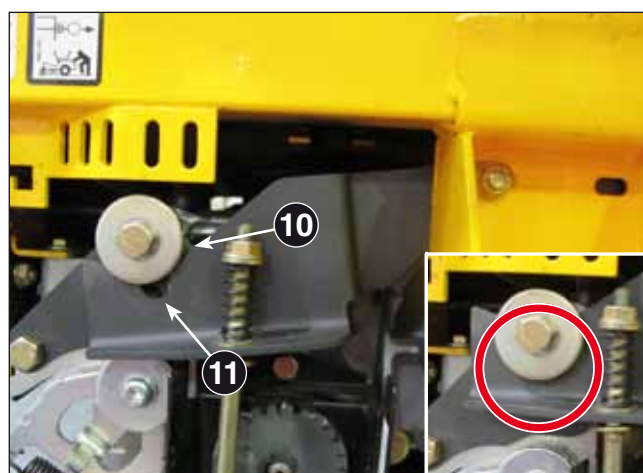
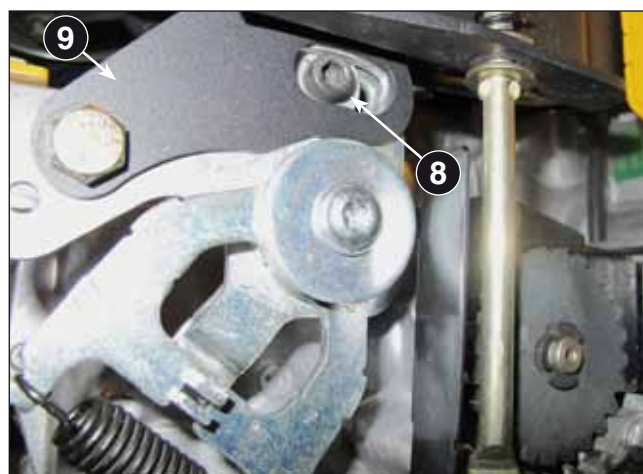
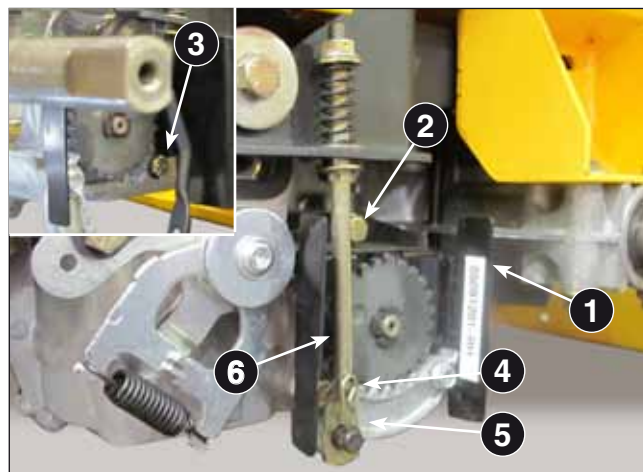

b) Adjusting the parking brake

! **WARNING!** - *When the adjustments have been made, the parking brake should prevent the machine from moving on a slope of 30% (16°) with the driver in position.*

1. Loosen the nut (12) and move the lever (13) until the pin (10) enters the slot (11) correctly.

2. Block the nut (12).

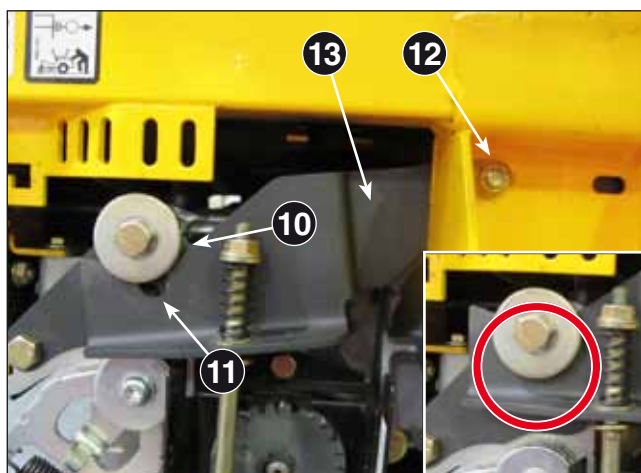

On completing the above adjustments a) and b), reassemble following the above instructions in the reverse order.

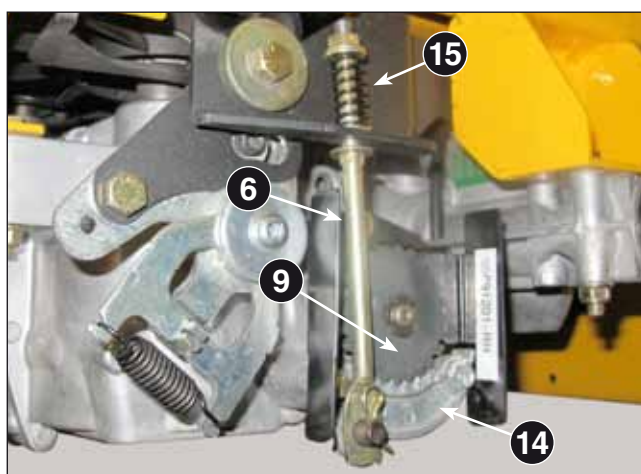

When reassembling the parking brake rod (6), check that, when the brake is engaged, the toothed section (14) remains engaged with the cogwheel (9) with a spring (15) compression of 3-4 mm with respect to its free length.

! The parking brake is adjusted correctly when it stops both the hydrostatic units and activates the safety microswitch.

c) Adjusting the parking brake microswitch

! Check that the microswitch (16) works correctly by engaging and disengaging the parking brake; if this is not the case, loosen the screws (17) and reposition it so that it opens and closes the contacts each time the lever is used.

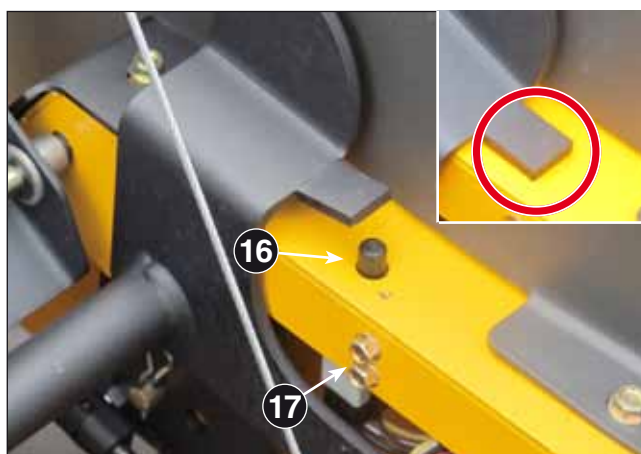

d) Adjusting the parking brake lever

The parking brake lever movement uses a spring (18), which can be adjusted to determine the force exercised to engage the lever, and the capacity to maintain the "brake engaged" position.

Loosen the locknut (19) and adjust the nut (20) to regulate the spring load:

- screwing it onto the rod (21) to decrease the force required to engage and maintain the "brake engaged" position;
- unscrewing it to achieve the opposite effect.

Remember to tighten the locknut (19) again after completing the procedure.

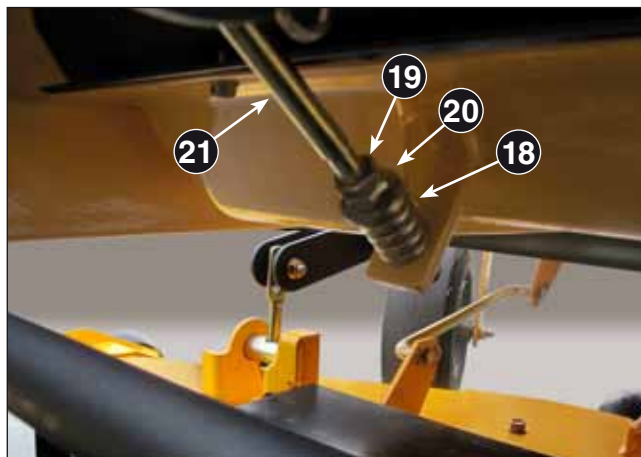

5.2.2 Adjusting maximum operating speed

NOTE The hydrostatic transmission units have a predetermined range of use, given by the sum of the maximum speeds in forward and reverse gear.

Therefore, any increase of either of the two parameters reduces the other, and vice versa.

Maximum forward gear speed is given by the distance between the holes on the two rods (1) and (2) and has a factory default setting of 670 mm.

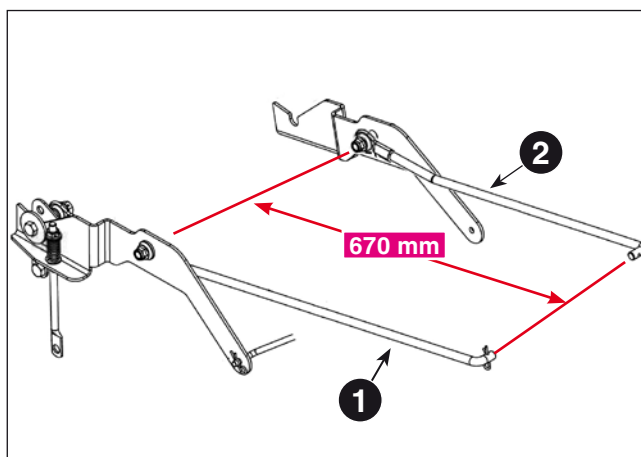

NOTE When replacing one or both rods, check that this value is complied with on both sides, to avoid calibration deviations between the two transmission units.

5.2.3 Replacing the shock absorber

The shock absorber is used to bring the corresponding lever back to the "neutral" position. If it brings it back too quickly, it is necessary to replace the shock absorber.

NOTE Always replace one shock absorber at a time.

The shock absorbers are positioned horizontally in the space under the seat.

To remove the shock absorber (1), unscrew the two nuts (2) which fasten the spherical pins on the heads in place.

During reassembly, make sure the new shock absorber is positioned with the piston crown facing the rear section of the machine.

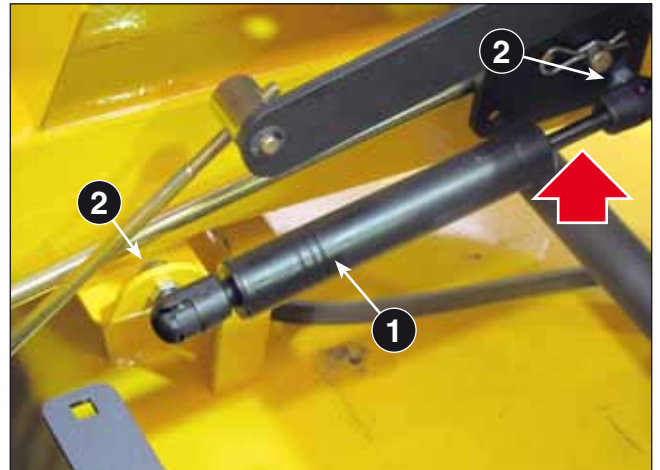

5.2.4 Replacing the transmission belt

- Follow steps 1 to 5 of the "Blade control belt replacement" procedure [👉 6.3.1].

1. Disconnect all electromagnetic clutch cables.
2. Undo the two screws (1) and remove the heatproof baffle (2) to facilitate the next operations.

3. Loosen the fixing screw (3) on the clutch (4).

4. Hold the two parts of the blade control belt (5) to release it from the clutch pulley (6).

5. Undo and remove the screw (3) and remove the clutch (4) from the engine shaft.

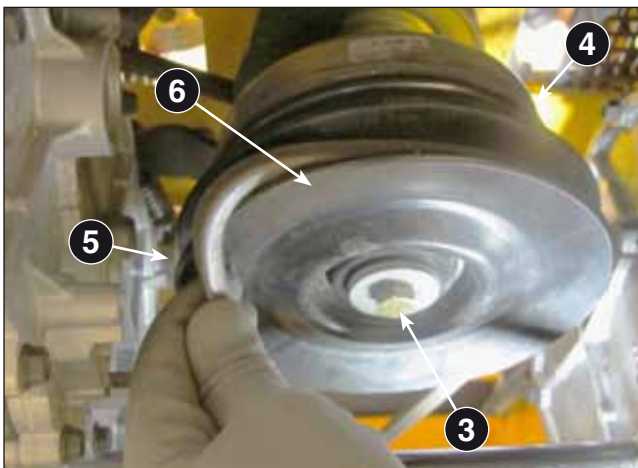
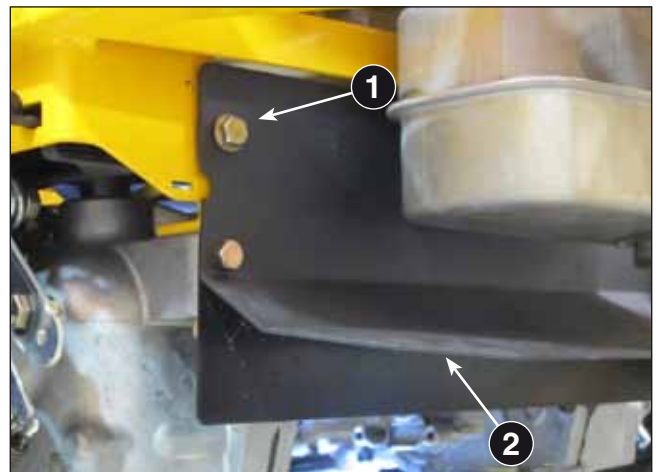

6. Free the belt (8) from transmission unit pulleys (9).

7. Fit the new belt (8) following the indications illustrated in the diagram.

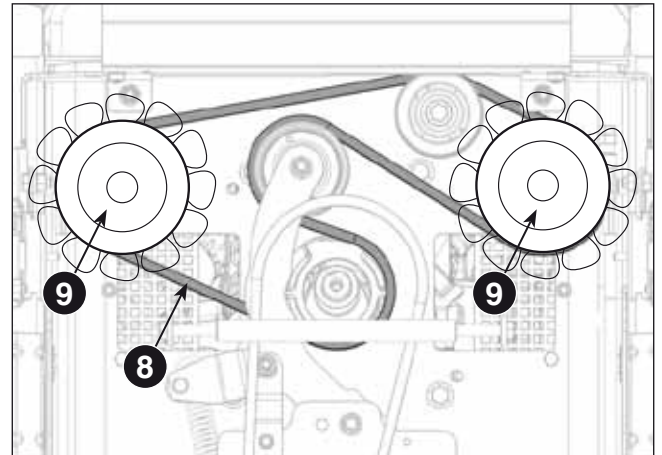

- Follow steps 1 to 5 of the "Blade control belt replacement" procedure in the reverse order to reassemble the clutch and blade control belt [👉 6.3.1].

5.2.5 Removing the transmission units

- Lift the rear part of the machine [👉 2.3.3].
- Remove the rear wheel on the side required [👉 5.3.1].

1. Undo the two screws (1) and remove the heat-proof baffle (2) to facilitate the next operations.

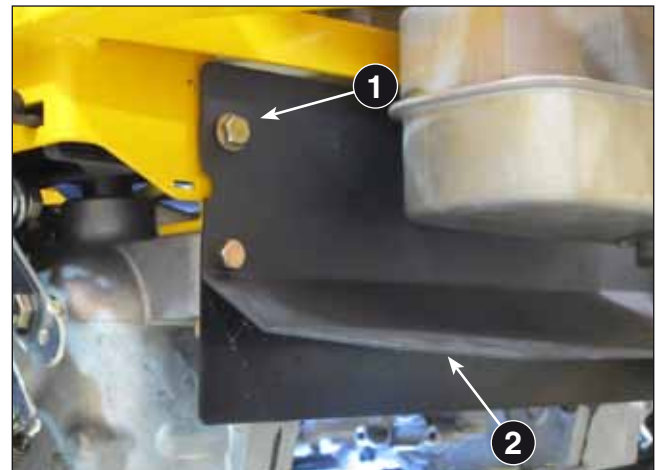

2. Loosen the tension of the drive belt on the transmissions. Measure the threaded projecting part of the pin (3) in relation to the nut (4), then loosen the nut (4) and release the tensioner spring (5).

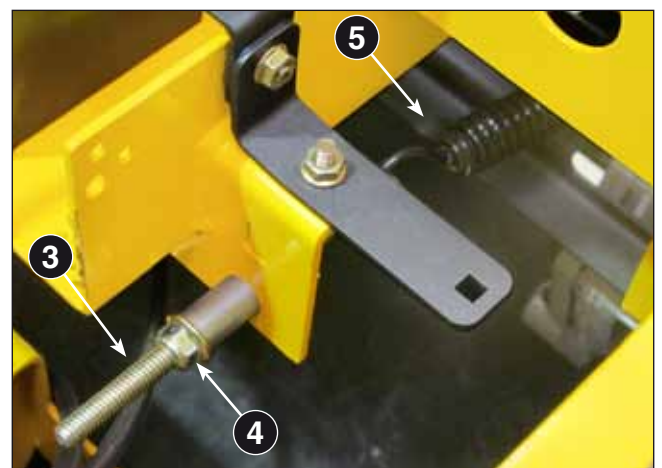

3. Free the belt (6) from the pulley (7).

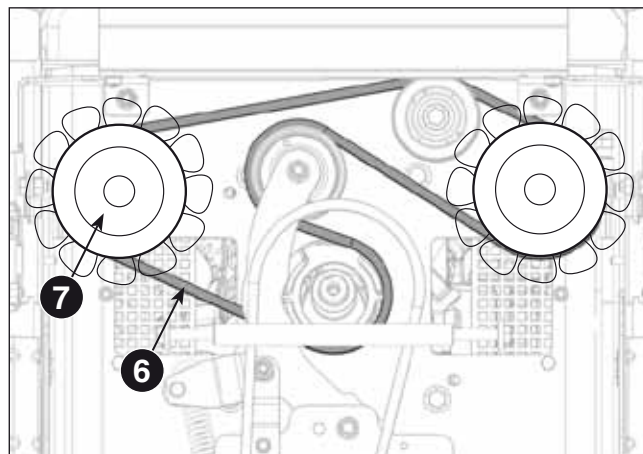

4. Undo the screw (8) fastening the connection rod (9) from the side of the transmission to be removed.

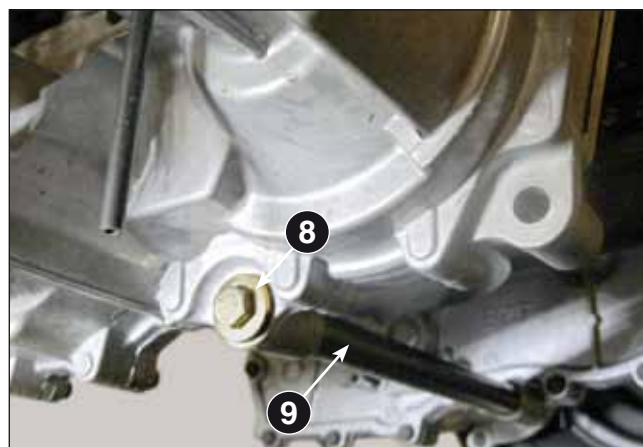

5. Release the split pin (10) and disconnect the parking brake rod (11).

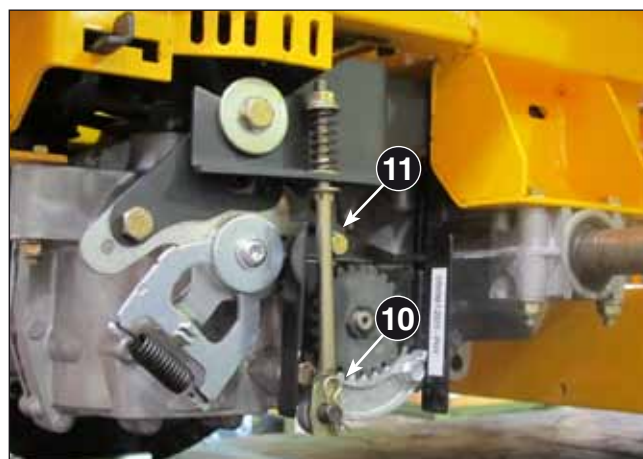

6. Undo the screw (12) and disconnect the bypass lever (13).



7. Unscrew the nut (14) and disconnect the rod joint head (15) from the drive control lever.

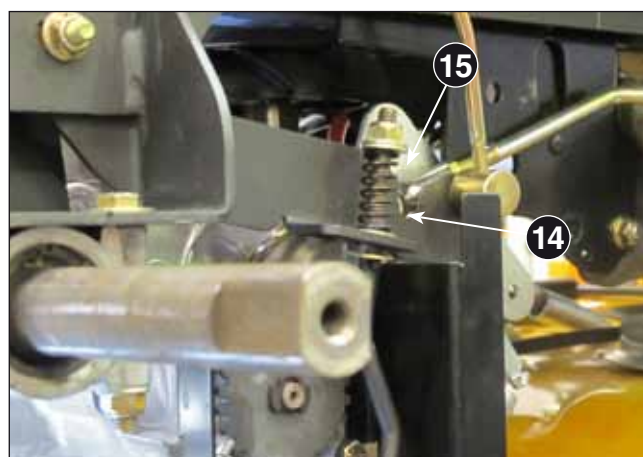

8. Undo the brake screw (16), unscrew the nut (17) and remove the plate (18).

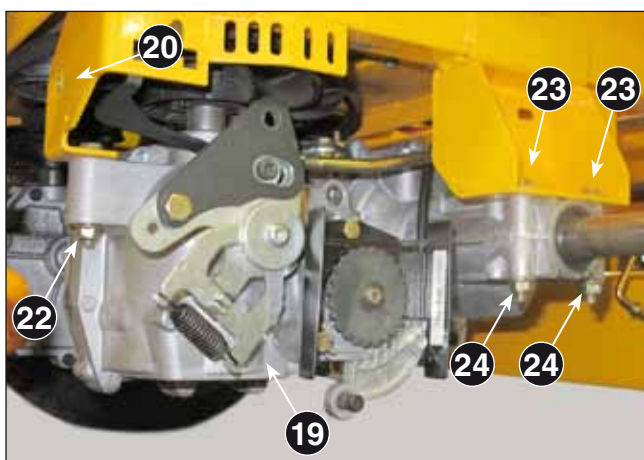
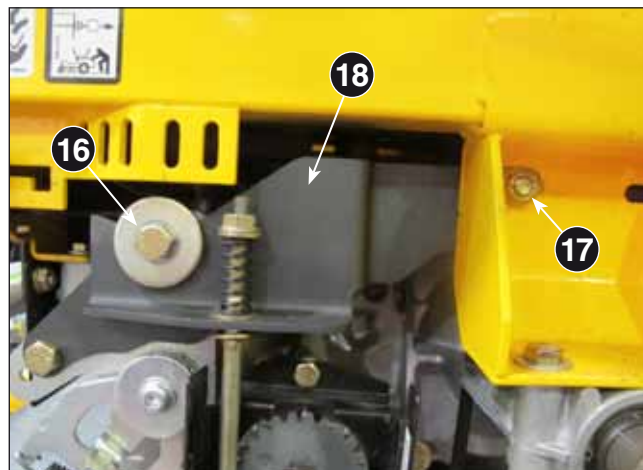

9. Each transmission unit is supported by a rear holder (19) and a front holder (21) to which it is fixed by two screws with relative nuts (22) and is fixed to the chassis by two screws (23) with relative nuts (24). Undo the nuts (22) and then carefully undo the two lower nuts (24), holding up the unit so that it does not fall.

When reassembling, perform the operations described above in the reverse order.

- Tighten the nuts (22) with a torque of 33-37 Nm.
- Tighten the nuts (24) with a torque of 33-37 Nm.

NOTE After replacing a hydrostatic unit, we recommend moving the by-pass (25) lever 5-6 times in both directions, so as to allow the redistribution of the oil inside the unit.

When assembly is complete,

- Check the parking brake works properly [👉 5.2.1b].



5.3 WHEELS AND TYRES

5.3.1 Removing and replacing the rear wheels

- Lift the rear part of the machine [2.3.3].

The rear wheels (1) are fixed to the hydrostatic unit shaft by a screw (2).

NOTE *If a wheel is jammed onto the shaft, use a release spray directing it around the press-fitting hole.*

WARNING! - *ALWAYS* replace deformed rims as they could impair the hold of the tyre.

On assembly it is advisable to spread grease on the shaft to facilitate the next wheel removal.

Tighten the screw (2) to a torque of 65-98 Nm.



5.3.2 Replacing the front wheels

- Lift the front part of the machine [2.3.2].

Undo the screw (1) and remove the wheel (2) from the support fork (3).

NOTE *The replacement wheel is available together with the tyre and to the bearings.*

On reassembling, make sure that the spacer (4) is positioned correctly and grease the bearings using the designated greaser device (5).

Tighten the screw (1) to a torque of 124 Nm.

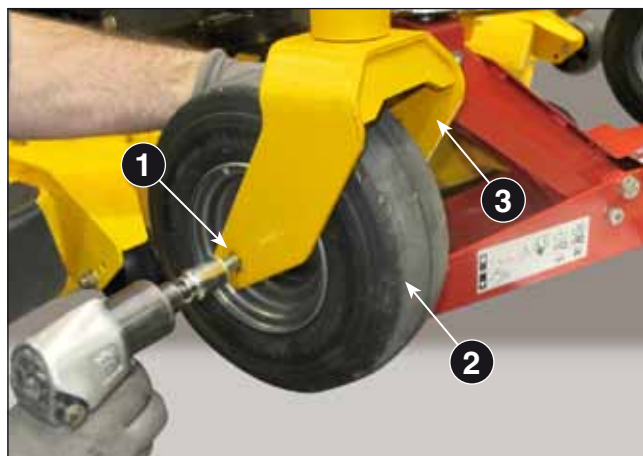

5.3.3 Replacing the front wheels pin bearings

- Remove the front wheel [5.3.2].

1. Remove the top cover (1) and undo the screw (2) to slide the fork (3) out of the hub (4).

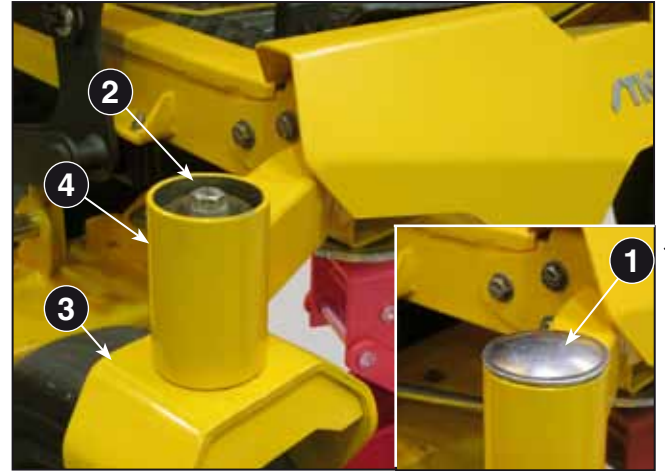

2. Remove the bearings (5) by hitting it from the inside of the hub with a round bar 12 ÷ 15 mm in diameter.

IMPORTANT *We recommend you always replace both hub bearings.*

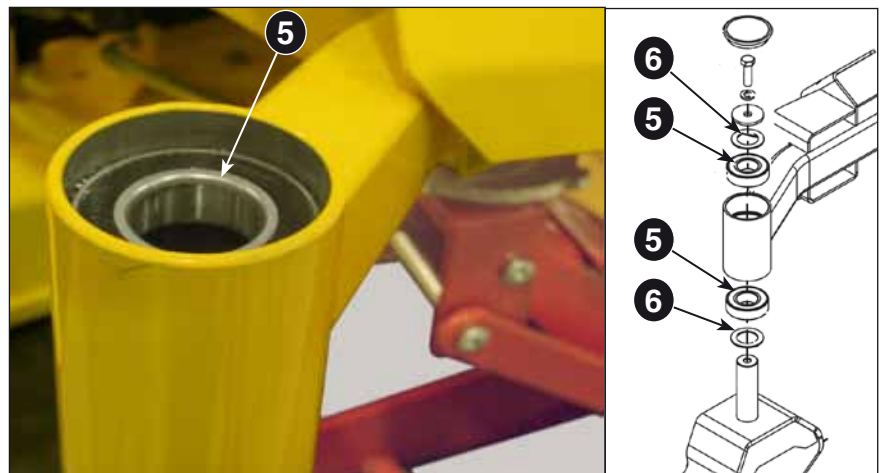

On reassembly, make sure the two shim washers (6) are positioned correctly.

Tighten the screw (2) to a torque of 124 Nm.

5.3.4 Replacement and repair of tyres

The tyres used on this machine are of the «Tubeless» type and so every repair of a hole in the tyre must be done by a tyre specialist according to the methods used for this type of tyre.

IMPORTANT *The rear tyres can have different rolling diameters, due to wear or after replacement of one of the two. These differences must never be offset by varying the inflation pressure, which must ALWAYS be the same for both.*

After the replacement of one or both tyres, it is always necessary to:

- check the tyre pressure [3.1];
- check the height of the blades from the ground [6.1.2].

6 - CUTTING DECK

Summary

6.1 ADJUSTING THE CUTTING DECK	31
6.1.1 General information	31
6.1.2 Adjusting the blade height	31
6.2 BLADE MAINTENANCE	33
6.2.1 Access to the lower section of the cutting deck	33
6.2.2 Checking blade alignment	33
6.2.3 Checking blade condition	33
6.2.4 Removing and reassembling the blades.....	34
6.2.5 Sharpening and balancing the blades	34
6.3 REPLACEMENT PROCEDURES	35
6.3.1 Blade control belt replacement	35
6.3.2 Replacement of the blade flanged supports	36
6.4 REMOVAL OF THE CUTTING DECK	37
6.4.1 General information	37
6.4.2 Removal and reassembly of the cutting deck	37

6.1 ADJUSTING THE CUTTING DECK

6.1.1 General information

Correct alignment of the cutting deck and blades is an essential condition to achieve even moving of the grass; the ideal working condition is achieved when:

- the external blades are at the same distance from the ground;
- the front end of the outer blades is 6 mm lower than the rear end.

The deck is supported by four adjustable rods, which can be used to achieve optimal alignment.

6.1.2 Adjusting the blade height

1. Check the tyre pressures.
2. Bring the cutting deck to its highest position.

NOTE *When measuring the blade heights it is recommended to use to use a suitable measuring instrument (1) or extensible abutments (2).*

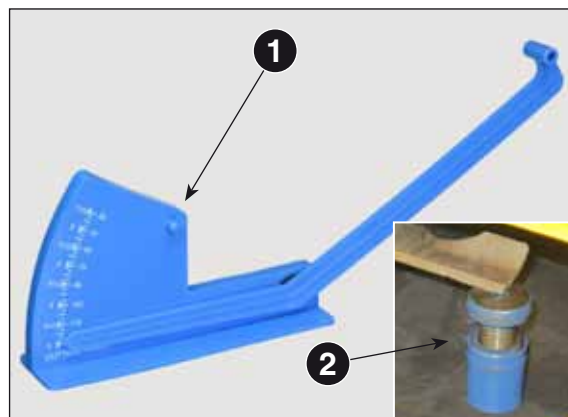

3. Manually rotate the two outer blades (3) and (4) so the tips are facing in the longitudinal direction (direction of travel).

⚠ WARNING! - Always wear protective gloves when handling the blades.

⚠ WARNING! -The blades are connected to each other; the rotation of each blade engages the rotation of the other.

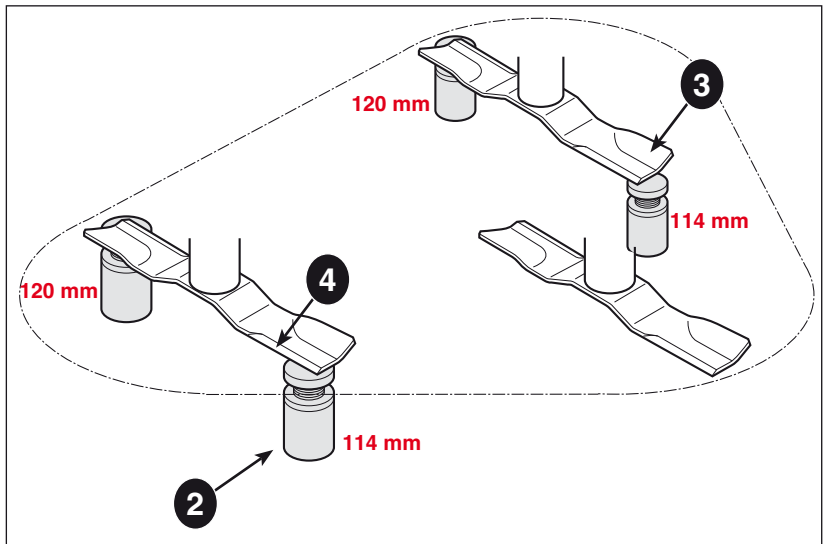

4. Place the abutments (2) under the ends of the blades, adjusted using the following values:

- 114 mm = below the front end;
- 120 mm = below the rear end.

or,
insert the measuring instrument (1) moving the feeler in line with the two ends of each blade.

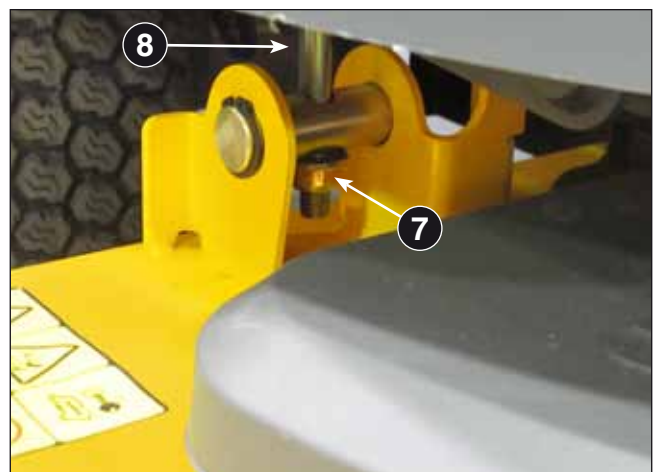
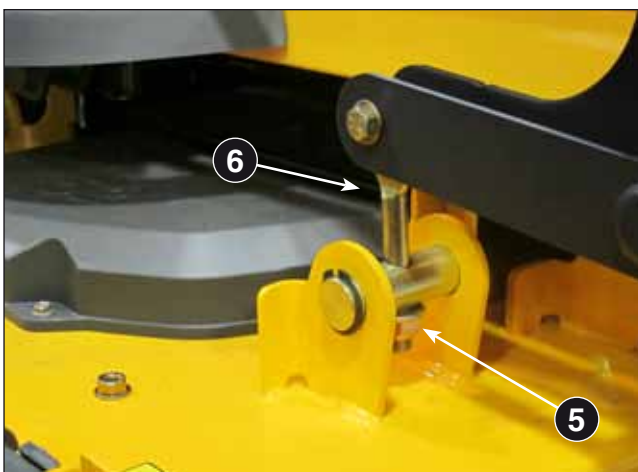
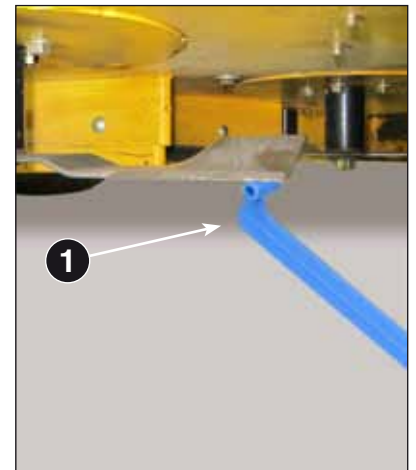
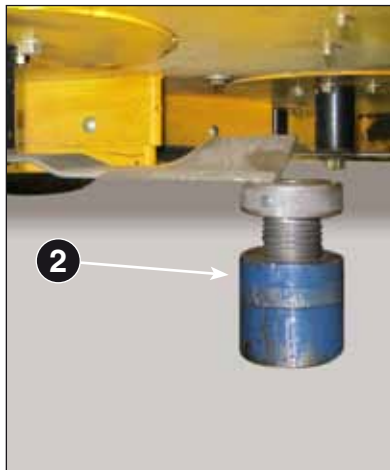

5. Adjust the lower nuts (5) on the two front rods (6) and the lower nuts (7) on the two rear rods (8), first on one side and then the other, until the two ends of the two blades reach the indicated measurements.

6.2 BLADE MAINTENANCE

6.2.1 Access to the lower section of the cutting deck

NOTE All operations described in this section can be performed without having to remove the cutting deck from the machine.

To make the lower section of the cutting deck more accessible, it is recommended to:

- Lift the front part of the machine [👉 2.3.2].

Place two blocks (1) about 50 cm high under the front wheels.

⚠ WARNING! Engage the parking brake. Do not exceed the angle of 25° when lifting the front part.



6.2.2 Checking blade alignment

⚠ WARNING! - Always wear protective gloves when handling the blades.

⚠ WARNING! - The three blades are connected to each other; the rotation of each blade engages the rotation of the other two.

1. Grasp two blades firmly together and rotate them so as to bring the cutting edges closer, then check that the gap between the two ends does not exceed 4-5 mm.
2. Repeat the operation approaching the cutting edges of the blades in the various different combinations.

Higher values can be caused by a deformation of the blades or of the flange support components. If this happens, replace all relative parts.

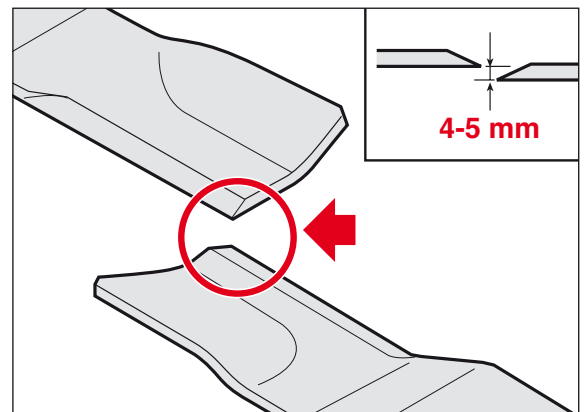

6.2.3 Checking blade condition

Carefully check the blades for breakages, deformations or cracks on both the blade and the fins.

⚠ WARNING! - Impaired blades must always be replaced and never repaired or straightened; to do so would cause damage or injury in the event of breakage during use.

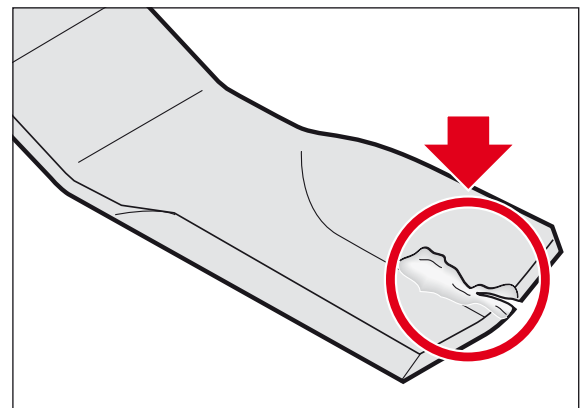

6.2.4 Removing and reassembling the blades

WARNING! - Always wear protective gloves when handling the blades.

WARNING! -The three blades are connected to each other; the rotation of each blade engages the rotation of the other two.

1. Grasp the blade (1) firmly and unscrew the central nut (2).

To assemble, tighten the nut (2) with a torque of 136-163 Nm using a power screwdriver and a torque wrench.

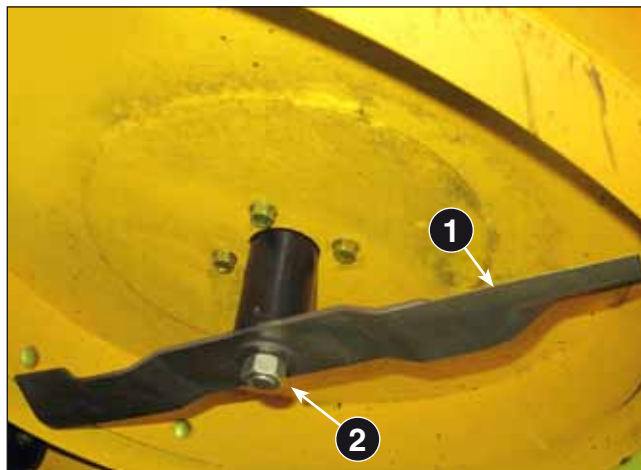

6.2.5 Sharpening and balancing the blades

A badly sharpened blade causes grass to become yellow and reduces grass collection capability; if not balanced, excessive vibration can be caused during use.

Always sharpen both cutting edges of the blade, using a medium grade grinder. Sharpening must only be performed from the side shown in the diagram, removing as little material as possible.

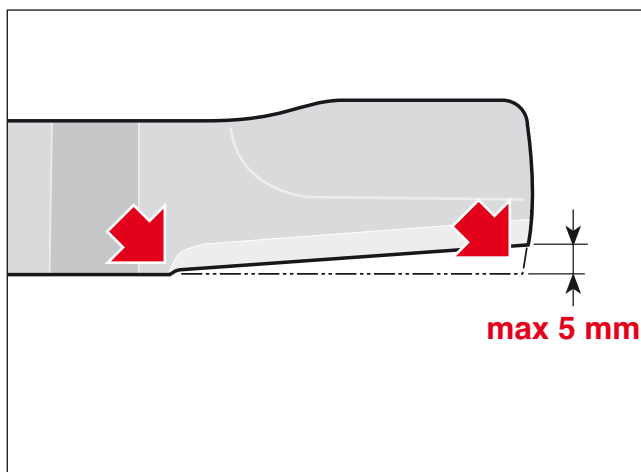

The blade is to be replaced when the cutting edge has worn down to 5 mm.

Using the appropriate equipment, check the balance to make sure that there is a maximum difference of 2 grams between one side and the other.

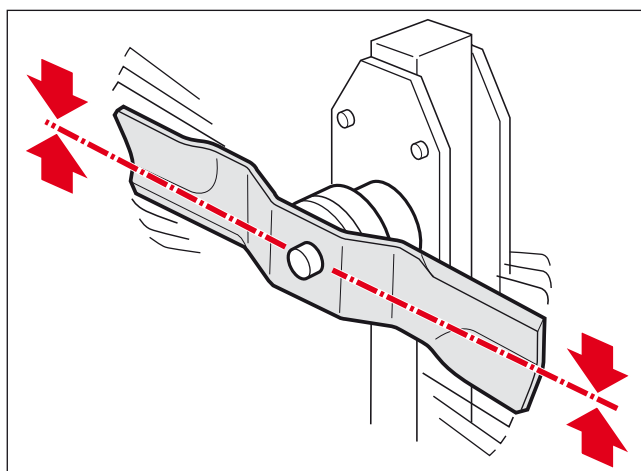

6.3 REPLACEMENT PROCEDURES**6.3.1 Blade control belt replacement**

1. Remove the left cover (1) fixed by three screws (2).
2. Remove the right cover (3) fixed by three screws (4).

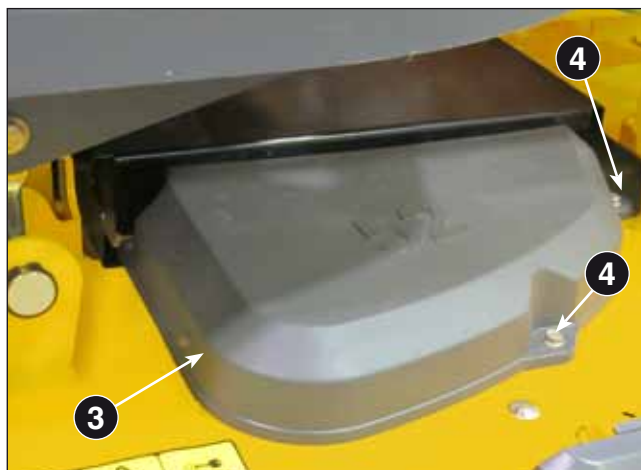

3. Remove the centre cover (5) fixed by four screws (6).

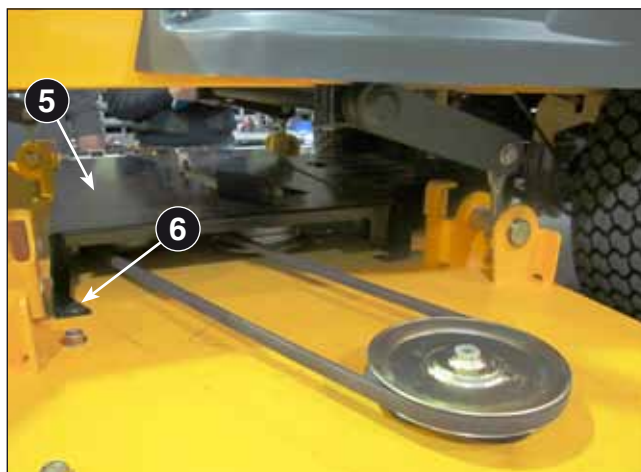

4. Release the spring (7) and rotate the tensioner arm (8) to loosen the belt (9).

5. Hold the two parts of the belt (9) to release it from the clutch pulley (10).

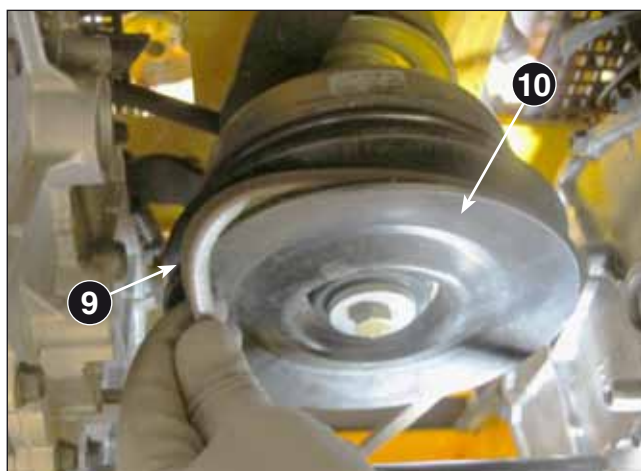
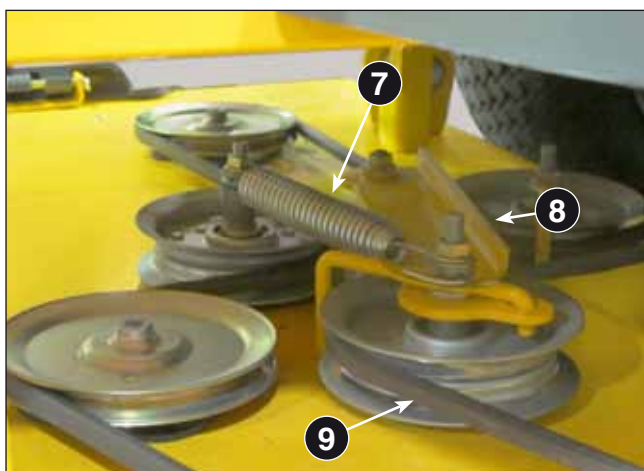

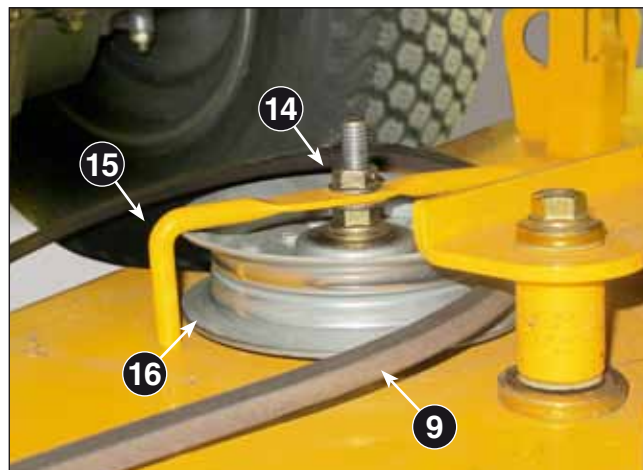
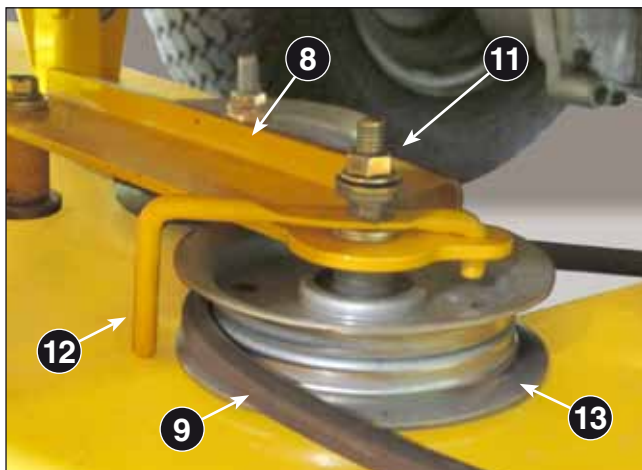

6. Loosen the nut (11) enough to move the belt guide (12) and free the belt (9) from the tensioner pulley (13).

7. Loosen the nut (14) enough to move the belt guide (15) and free the belt (9) from the drive pulley (16).

8. Fit the new belt following the indications illustrated in the diagram.

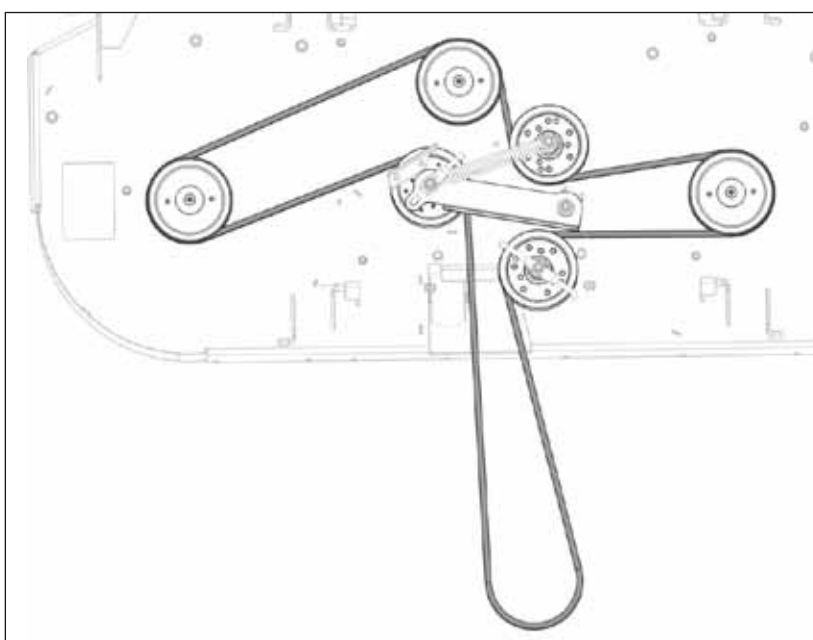

Reassemble all removed parts, following the above instructions in the reverse order.

6.3.2 Replacement of the blade flanged supports

- Lift the front of the machine and stabilise it to allow required accessibility [👉 6.2.1].
- Remove the blade to be replaced from the flanged support [👉 6.2.4].
- Follow steps 1 to 4 of the "Blade control belt replacement" procedure [👉 6.3.1].

Undo the four screws (1) and extract the flanged support (2) from the upper part of the cutting deck.

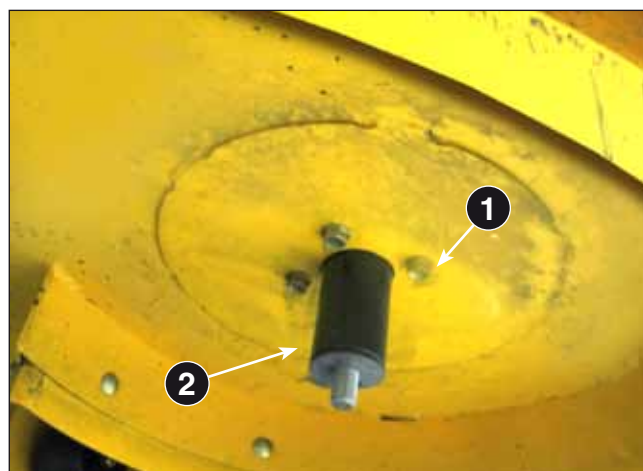

NOTE - The entire support element (3), including shafts and bearings, is a spare part available as single assembly unit, including the pulley.

Reassemble all removed parts following the above instructions in the reverse order, making sure to tighten the four screws (1) with a torque of 36-40 Nm using a power screwdriver and a torque wrench.



6.4 REMOVAL OF THE CUTTING DECK

6.4.1 General information

By removing the cutting deck you can carry out all servicing and replacement operations on the blade flanged supports and the drive systems more comfortably and easily. With some practice and experience it is possible to do this job with the deck still in position.

6.4.2 Removal and reassembly of the cutting deck

1. Place blocks under the edge of the deck edge and lower the deck so that you can lean on it, without the risk of falling during removal.
2. Remove the left cover (1) fixed by three screws (2).
3. Remove the centre cover (3) fixed by four screws (4).



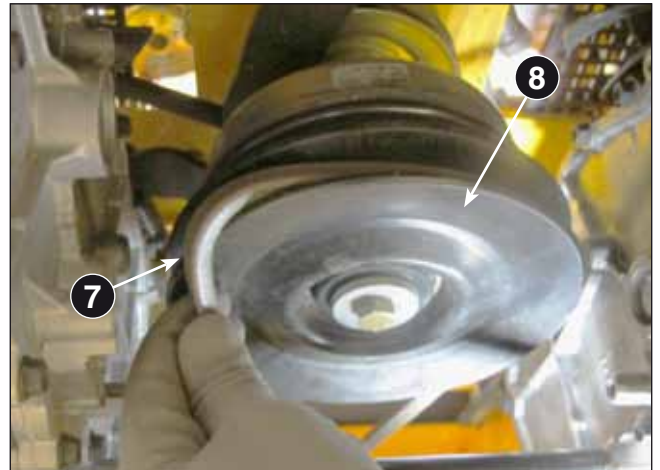
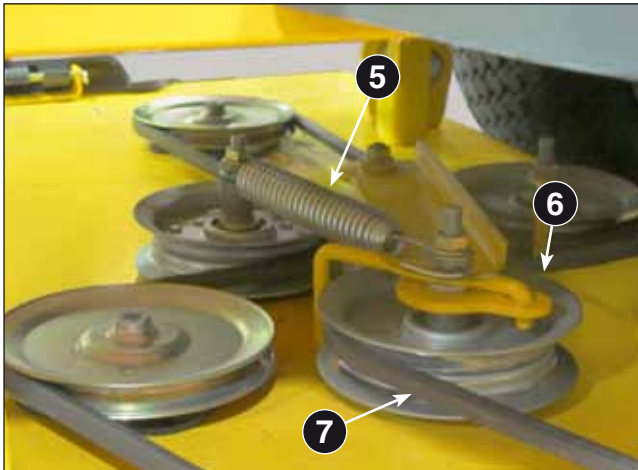

4. Release the spring (5) and rotate the tensioner arm (6) to loosen the belt (7).
5. Hold the two parts of the belt (7) to release it from the clutch pulley (8).

6. Remove the split pin (9) and disconnect the left rocker arm (10). Repeat the operation to disconnect the right rocker arm.

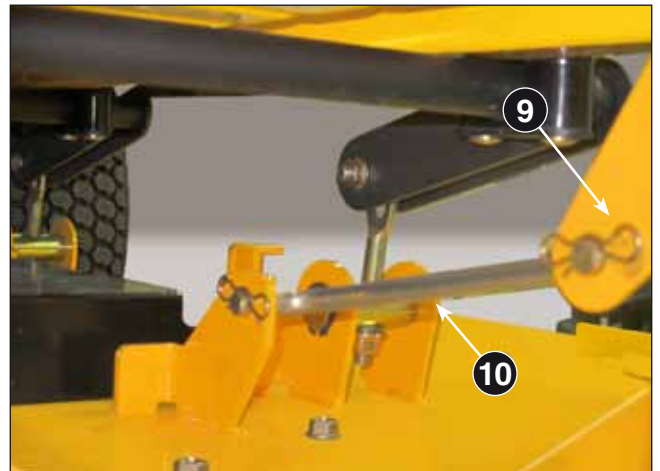

7. Identify the four support rods (11), unscrew the nut (12) and remove the screw (13), being careful not to lose the connecting elements, including the washer (14), the shorter internal spacer bar (15) and the bushing (16).

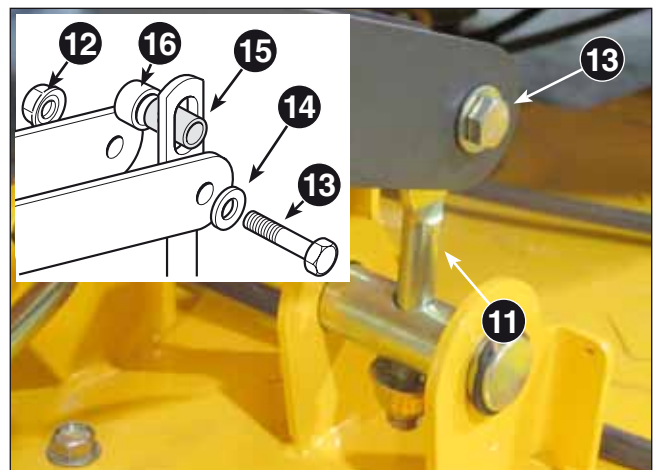

8. Remove the cutting deck, sliding it out from the right hand side.

Reassemble all removed parts, following the above instructions in the reverse order, paying attention to:

- Correctly reposition the short spacer bars (15) in relation to the slot on each rod (11).
- Tighten the nuts (12) with a torque of 33-37 Nm.

On completing the reassembly, adjust the height of the blades in relation to the ground [👉 6.1.2].

7 - ELECTRICAL SYSTEM

Summary

7.1 TROUBLESHOOTING.....	39
7.1.1 Electrical system problem table	39
7.1.2 Safety device intervention table	40
7.1.3 Equipment	40
7.1.4 Electrical measure gauges	41
7.1.5 Electrical measurements	42
7.2 SYSTEM AND COMPONENT DESCRIPTIONS	42
7.2.1 Wiring	42
7.2.2 Battery	43
7.2.3 Switches	45
7.2.4 Ignition switch	47
7.2.5 Relays and Solenoids	47
7.2.6 Fuses.....	48
7.2.7 Diodes and Rectifiers	49
7.2.8 Electromagnetic clutch	49
7.3 FUNCTIONAL CHECKS.....	50
7.3.1 General system checks	50
7.4 ELECTRICAL WIRING DIAGRAMS.....	52
7.4.1 Wiring layout.....	52
7.4.2 Operating layouts in user modes	53

7.1 TROUBLESHOOTING

7.1.1 Electrical system problem table

Below are some of the most common problems connected to the malfunctioning of the electrical system are shown, with their probable cause and the remedial action to be taken.

PROBLEM	CAUSE	REMEDY
Engine does not start	The ignition consent conditions have not been complied with	Comply with all consent conditions and test all the microswitches [7.1.2] - [7.2.3]
	Low battery	Recharge the battery [7.2.2]
	Uncertain battery cable connections	Check and clean the terminals [7.2.2]
	Uncertain spark plug connections or faulty spark plugs	Check and replace
Electromagnetic clutch malfunction	The operator is absent	Comply with the consent conditions [7.1.2]
	The operator present switch is faulty	Check and replace [7.2.3]
	Faulty switch, diode or clutch	Check the components [7.2.3] - [7.2.7] - [7.2.8] and replace them

7.1.2 Safety device intervention table



The safety devices intervene on the engine, preventing ignition or stopping it in the event where the required machine operating conditions are no longer met.

The following tables show the correlations on the engine produced by the safety devices in all the various possible situations.

a) The engine starts when:

Parking brake	Operator	PTO Blade Control
Engaged (ON)	Seated	Disengaged (OFF)
Engaged (ON)	None	Disengaged (OFF)

b) Effects on the engine in operating conditions with:

Parking Brake	Operator	PTO Blade Control	Effect on the Engine
Engaged (ON)	Seated	Engaged (ON)	Keeps running
Engaged (ON)	Seated	Disengaged (OFF)	Keeps running
Engaged (ON)	None	Engaged (ON)	Stops
Engaged (ON)	None	Disengaged (OFF)	Keeps running
Disengaged (OFF)	Seated	Engaged (ON)	Keeps running
Disengaged (OFF)	Seated	Disengaged (OFF)	Keeps running
Disengaged (OFF)	None	Engaged (ON)	Stops
Disengaged (OFF)	None	Disengaged (OFF)	Stops

7.1.3 Equipment

There are some specialised tools and test equipment that are needed for electrical repair work. A brief description of these follows.

- **Needle-nose or long pliers.** Used to connect or bend wires and connectors in tight positions.
- **Diagonal cutters.** Used to cut wires or trim connections.
- **Wire stripper / crimping tool.** Available separately or as a combined tool. Used to strip insulation from wires of various sizes, crimp terminals and connector or wires.
- **Soldering iron and soldering gun.** Used to well all the couplings and connections to terminals, connectors etc. A soldering gun is faster and more convenient than a soldering iron, which must heat up first.
- **Multimeter - analog or digital.** To measure voltage, amperage and ohms.
- **Tachometer.** Used to measure engine speed. Required to properly test alternator and charging cir cuits where output is dependent upon engine speed.
- **Heat gun.** Used to hot shrink insulated tubing in place. Used to replace electrical tape or insulated sleeving. To use, place a piece of shrink tubing over a wire joint, heat with the heat gun, until it shrinks slightly around the joint.
- **Consumable materials.** Electrical tape, resin core solder (never use acid or acid core solder on electrical joints), an assortment of various sized terminals, connectors, insulated or heat shrink tubing (for use on joints and connections), and an assortment of automotive type wire (in several colours).

IMPORTANT *STIGA highly recommends that all interventions be performed in a professional manner. The use of the tubing to cover joints and the soldering of connections contribute to a professional looking job. In addition to a pleasing appearance, repairs made in this manner are more likely to withstand vibration. (The weakest points in an electrical system are the joints where wires are attached.)*

IMPORTANT Replace all faulty components with STIGA replacement parts only. *Engine parts, such as rectifiers or alternator components should be repaired by the nearest engine service center. STIGA does not recommend attempting to repair electrical components. Most do not lend themselves to repair and you would have more money invested in "time of repair" than the part would cost and the results may not be as good.*

7.1.4 Electrical measure gauges

In many electrical circuits, there is some visible effect which indicates that the circuit is functioning properly. A switch is turned "ON" and a lamp lights. A key is turned, a starter motor runs and cranks the engine. If the lamp does not light up, or the starter motor does not run, some means of measuring voltage, current flow, resistance and continuity is needed, (continuity means there is a complete electrical path through the circuit or component.)

To know exactly what conditions exist in an electrical circuit requires AC and DC Voltmeter, AC and DC Ammeter, and an Ohmmeter.

Combination meters that do all of these things are available and called a Multimeter or Volt Ohm-multitester (VOM).

Meters of this kind are available in many forms and all change functions and ranges with switches, or by plugging test leads into different jacks. Multimeters are available in two basic types, Analog and Digital.

- **Analog meters**

Analog meters have a needle that provides the reading moving along a scale. The longer the scale, the easier it is to read and more accurate the reading will be. A jewelled movement is used in this type of meter which is more likely to be damaged through rough handling (except for overloaded Protected Meters) or by measuring high values that exceed the range set on the meter, than a digital meter.

They provide excellent service for the money as long as they are used with care.

- **Digital meters**

Digital Meters do not have a movement and are therefore more rugged. The reading shows up directly on a display window of some type. Since they read direct, no skill in reading the scale is required, nor is it necessary to set the range. The meter switches the ranges automatically.

The user only has to select the function volts DC, AC amps, ohms, etc.), connect the test leads and the reading is displayed on the display. Because of the internal circuitry and the lack of a movement, these meters are not likely to be damaged by overloads.

In the discussions that follow, either type of meter may be used. Test procedures are the same. It is best to learn proper procedures, even though some meters may be more forgiving of mistakes. Where differences in use may occur, they will be covered in the discussion.

7.1.5 Electrical measurements

• Voltage measurement

There are two basic rules to be remembered when using a voltmeter. A voltmeter measures the voltage difference between the test leads and the voltmeter is always connected across the circuit under test.

• Current measurement

The two rules to remember when measuring current with an ammeter are; an ammeter measures the current that flows through the meter, and to measure current an ammeter must be connected into the circuit.

The latter rule means that the circuit must be opened, and the ammeter wired into it. Because this procedure is usually difficult, an ammeter is seldom used for troubleshooting.

• Resistance measurement

An Ohmmeter is used to make resistance measurements and to check continuity through wires and electrical components.

There is one rule to keep in mind when using an ohm meter. The ohmmeter has a self contained battery and requires no electrical power. Using the ohmmeter on a circuit that has voltage applied may result in damage to the meter.

IMPORTANT - *Disconnect the battery from the machine when performing Ohmmeter tests or damage to the Ohmmeter may occur.*

IMPORTANT: - *An ohmmeter reads the resistance of whatever component is connected between the test leads. It can be used to check wires, coils, light bulbs, or any item that conducts current.*

7.2 SYSTEM AND COMPONENT DESCRIPTIONS

7.2.1 Wiring

The diagram shows the cabling layout and the arrangement of the utilities.

1. PTO
2. Relays
3. Bipolar switch
4. 25 A fuse
5. 10 A fuse
6. Normally open switch (NO)
7. Normally closed switch (NC)
8. Diode
9. Ignition solenoid

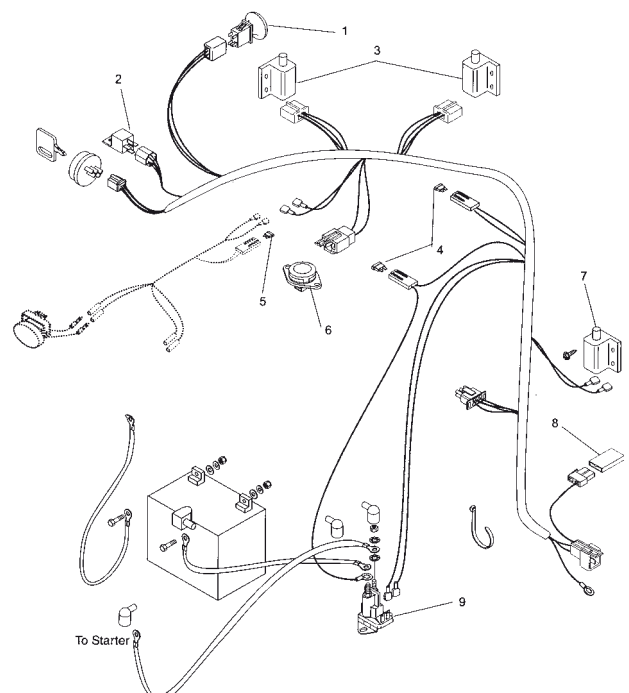

7.2.2 Battery

NOTE - The machine comes equipped with a maintenance-free battery that requires no regular maintenance except the cleaning of the terminals.

! DANGER! - Battery poles, terminals and related accessories contain lead and lead compounds, chemicals known to cause cancer and damage to the reproductive apparatus. Wash hands after handling

Remove battery before servicing.

a) Battery Removal and Installation

- Disconnect the negative (-) cable first, then the positive (+) cable.
- Remove the battery hold-down bracket and battery from the machine.
NOTE - Several different batteries can be assembled on the machine that involve a different composition of the hold-down bracket.
- Connect the positive (+) cable first, then the negative (-) cable.
- Apply petroleum jelly or dielectric grease to battery cable ends and terminals.

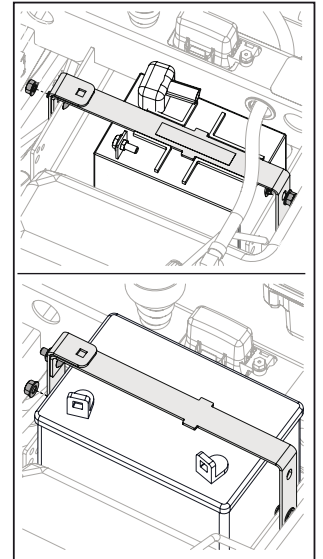

b) Inspection, cleaning, drying, and maintenance

- Inspect the top of the battery, terminals, cables, poles and the battery unit for any accumulation of dirt, corrosion cracks or loose or broken parts. Keep the battery and its terminals clean. Replace the battery if damaged.
- Clean or service the battery after removing it from the machine. Remove corrosion from battery terminals and cable connections with a wire brush, then wash with a weak baking soda solution.
- Scrub the exterior of the battery and cable terminals with a non-metallic brush which has been dipped into a mixture of baking soda and water.
- After cleaning, apply a thin coat of grease or petroleum jelly to terminals and cable ends to delay corrosion.

c) Recharging the battery

NOTE - ALWAYS follow the information provided on the battery by the battery manufacturer. Contact the battery manufacturer for further instructions on how to charge the battery.

- To charge the battery:
 1. Remove the battery from the machine
 2. Place the battery on bench or other well ventilated place.
 3. Connect the positive (+) lead of the charger to the positive (+) terminal, and the negative (-) lead to the negative (-) terminal.

The approximate charge status can be determined by the remaining open circuit voltage (OCV) at room temperature, and the charge time required can then be estimated, as indicated in the table of examples.

Voltage (OCV)	Charge %	Charging time
12.60	100%	--
12.40	75%	3 hours
12.20	50%	7 hours
12.00	25%	10 hours
11.80	0%	12 hours

- If you use a 12 volt automatic battery charger, select a good quality charger with minimum 5-10 Ampere output at 15 VDC and charge for 3-12 hours depending on the battery charge status (see table).
- If you are using a constant current charger, charge at 1-2 Amperes for the time indicated in the table.

IMPORTANT - *Charging at higher rates will damage the battery and cause excessive gassing and acid spewing.*

d) Charging with an alternator

Under normal conditions the engine alternator will keep the battery charged. If the machine is not used for a long period of time and the battery was fully discharged, a battery charger must be used to charge it again.

e) Emergency jump-start with cables

Jump starting, battery charging, or replacement is required when the starter motor will not crank the engine.

IMPORTANT - The machine used for jump starting should have a 12 volt battery with at least 500 cold cranking amperes, and a negatively grounded system.

 **DANGER!** - ***FROZEN BATTERIES CAN EXPLODE and result in death or serious injury. DO NOT charge a frozen battery. Let the battery thaw out before putting on a charger. UNIT MOVEMENT can result in death or serious injury. NEVER jump-start the machine with cables directly on the starter motor or solenoid valves The machine could move forward or backward and injure the person jump starting it.***

To jump-start with the cables:

1. Ensure battery is not frozen. If the fluid is frozen, remove the battery from unit and allow to thaw before charging.
2. Connect the positive (+) jumper cable to the positive (+) terminal of the discharged battery.
3. Connect the other end of the same jumper cable to the positive (+) terminal of the booster battery.
4. Connect one end of the second jumper cable to the negative (-) terminal of the booster battery.

5. Make the final jumper cable connection to the engine block or the furthest ground point away from the discharged battery.

WARNING! - *Make sure the cables are clear of any moving engine parts before starting the engine.*

6. Start the engine. If the engine will not start after several tries, the machine or battery may need servicing.
7. After engine starts, leave cables connected for one to two minutes.
8. Disconnect cables in reverse order.
9. Use the machine normally to charge the battery.

7.2.3 Switches

Switches either open a circuit to stop current flow or close and allow current to flow through.

- A normally open (NO) switch prevents current flow until the switch is actuated, completing the circuit and allowing current to flow through it. An example is a light switch - the lights are off until the switch is actuated and the lights go on.
- A normally closed (NC) switch allows current to flow until the switch is actuated, breaking the circuit and stopping current flow through it. An example is an ignition switch that grounds the magneto when in the OFF position (completing the circuit) but opens the circuit when in the ON position allowing the engine to operate. The switches are selected with reference to their nominal current (the contacts must be of sufficient size to carry the required current), rated voltage and type of actuation (pressure switches, traction, rotation, momentary contact or microswitches).

NOTE - *Check that the connections to the switches are stable and that the switch is actuated correctly before performing an electrical test (Safety switches may need adjusting in order to be actuated correctly).*

IMPORTANT - *During the check process, remove the switches from their respective circuit, unplugging the connector. If the cables are left in place, the machine components or the meter may be damaged.*

a) Normally Open Switch

To test a normally closed switch connect the ohmmeter between the switch terminals.

- The meter should indicate an open circuit (infinite resistance «∞»).
- Activate the switch. The Ohmmeter should indicate a closed circuit (zero resistance «0»).

This indicates the switch is operating properly. Variation from test results described indicates a defective switch.

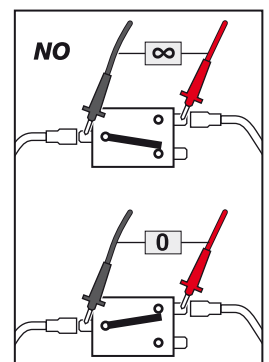

b) Normally Closed Switch (NC)

To test a normally closed switch connect the ohmmeter between the switch terminals.

- The meter should indicate a closed circuit (zero resistance «0»).
- Activate the switch. The Ohmmeter should indicate an open circuit (zero resistance «∞»).

This indicates the switch is operating properly. Variation from test results described indicates a defective switch.

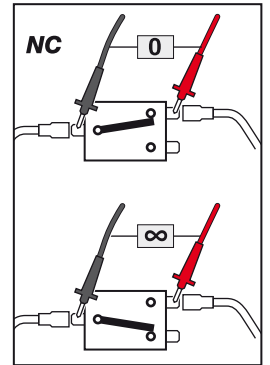

The diagrams show the connections of the electrical components in different situations.

NOTE - The continuous line indicates the electrical continuity of the circuit. All switches are shown from the rear.

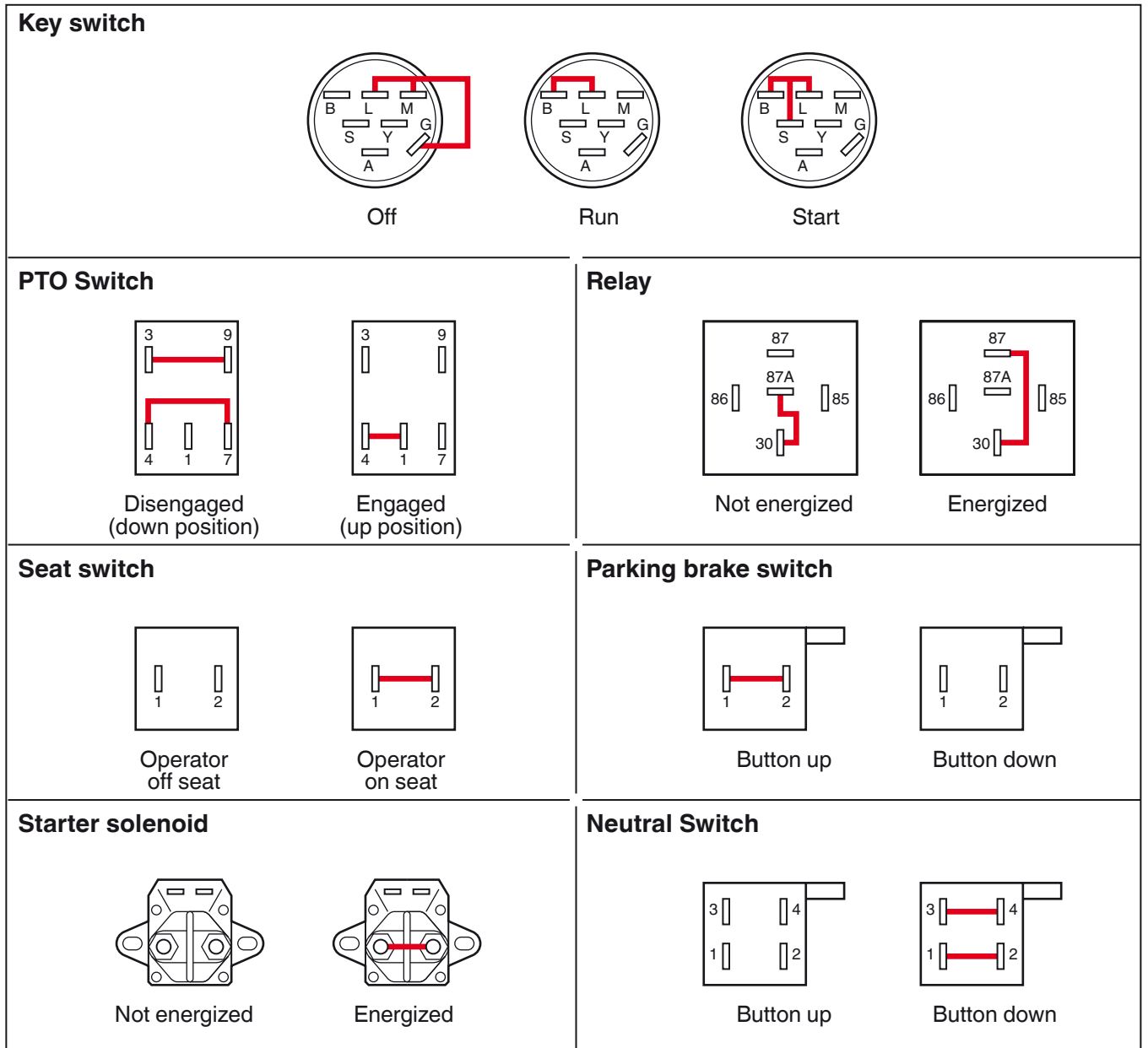

7.2.4 Ignition switch

NOTE - Refer to the wiring diagram of the machine (continuity diagram) to determine switch functions and test using the methods described.

The ignition switch incorporates a number of functions, although not all functions are used on all machines. It is a three-position switch: OFF, RUN, START with momentary contact. Use an ohmmeter to check for continuity in each position.

- **«OFF» Position** - There must be continuity between contacts G, L and M. These connections ground the engine magnet and stop the engine in the OFF position.
- **«RUN» Position** - There must be continuity between contacts B and L. These connections provide power to the rest of the wiring. Connections G and M open reciprocally.
- **«START» Position** - Hold the switch in the START position while testing. There must be continuity between contacts B, L and S. These connections apply power to close the solenoid contacts and engage the starter motor.

In addition to the tests above, set the switch to the «RUN» position and check between each contact and the ground (metal part) to ensure that no terminals are grounded. If the switch is functioning properly, there will be no continuity between the contacts other than that described.

7.2.5 Relays and Solenoids

Solenoid and relays are both magnetically operated devices. Both devices operate on the principle that passing a current of electricity through a coil of wire will create a magnetic field strong enough to attract a piece of iron or steel. Each device uses this principle in a slightly different manner.

- **Relay** - A basic relay consists of a coil of wire wound around a soft iron (magnetic) core. When current is passed through the coil, the core is magnetized and pulls down on a magnetic lever. The lever in turn is attached to several switch contacts which open or close other electrical circuits. In this fashion, a small current can control one or more larger electrical currents and actuate several other devices. In most cases a relay contact moves only a fraction of an inch and the magnetic pull is low.
- **Solenoids** - A basic solenoid consists of a coil of wire wound around a hollow tube. A magnetic core slides inside the tube. When current is passed through the coil, the core is pulled into the solenoid with considerable force. With proper design, a solenoid can exert considerable force over a distance of several inches. A solenoid can therefore, pull a lever, close a heavy contact, or perform other jobs that require a straight line pull.

If a relay or solenoid fails to operate the cause may be either electrical or mechanical.

To check electrically, connect a voltmeter across the coil of the device and activate the circuit that operates the relay or solenoid. If the meter indicates no voltage is applied, the cause lies in the control circuit.

If the meter indicates proper voltage across the coil but the device does not function, remove the power, disconnect the wiring and check the continuity of the coil with an ohmmeter. The meter should indicate resistance, in the order of 3 to 5 ohms, if the coil is intact. A high resistance indicates an open coil and a defective device.

There are also a number of mechanical issues that may cause the problem.

The starter solenoid used on STIGA machines is a sealed unit used to actuate the starter motor on the engines. These solenoids may have three or four connections. The two major connections carry high current to operate the starter motor. The minor connections are connected to the coil and carry the control current.

To check the solenoid, disconnect the cables to the starter motor, turn the ignition switch to the start position, and listen for the solenoid to snap inside contacts closed.

If no snap is heard, check across the coils with a voltmeter. The voltage should read 12 volts with the ignition switch in the «START» position. If no voltage appears, the defect is in the start circuit.

If the voltage is correct, turn off the power and check continuity of the coil with an ohmmeter. If the coil is open, the solenoid is faulty and must be replaced. If the coil has the proper voltage applied, and the continuity check indicates the coil is intact, the solenoid plunger is stuck or the contacts are welded shut and the solenoid must be replaced.

If the solenoid snaps shut, but the starter motor does not work, check the power contacts with an ohmmeter. If there is no continuity when the solenoid snaps shut, the contacts are faulty and the solenoid must be replaced.

7.2.6 Fuses

Fuses are inserted in electrical circuits to protect the circuits from damage due to overload or short circuits. Fuses are a “weak link” in the circuit. They contain a metal link designed to melt when a certain current value is exceeded thus opening or disconnecting the wiring.

Once a fuse blows or melts it must be discarded and replaced with a new fuse of the same value. Since the function of the fuse is to protect the circuit, NEVER attempt to repair the protective device by bridging or replacing it with one with a higher current rating.

Electrical testing of these devices is simple, as the device either conducts current (and is therefore functioning) or the device is open and is therefore faulty Use an ohmmeter to check for continuity.

7.2.7 Diodes and Rectifiers

Diodes are solid state, semiconductor devices. They contain no moving parts and conduct current better in one direction than the other.

- **Diodes** - Diodes allow current to flow through one circuit without “backing up” into another. In engine alternator circuits, a diode is used to convert current which flows back and forth (AC) in a circuit to current which flows only in one direction (DC). A device which converts alternating current to a direct current is called a RECTIFIER. A diode is one type of rectifier.

To check a diode, isolate it from the circuit by disconnecting one end. With a multimeter set on the lowest ohms scale setting, measure the resistance in one direction, reverse the test leads, and measure in the other direction.

Readings should be high in one direction and low in the other.

- If the readings are the same in both directions, the diode has short-circuited.
- If the readings are high, the diode is open.
- If the readings are the same in both directions, the diode is faulty and must be replaced.

IMPORTANT - Diodes are marked to indicate polarity (a band on one end, an arrow on the side, or they fit on a holder only one way to prevent inverting the polarity).

- **Rectifiers** - The battery is charged via an alternator on the engine. A charging circuit contains a rectifier because alternators produce alternating current (AC) and batteries require direct current (DC) for charging.

The rectifier may be built into the engine or it may be an external component. It may also contain a regulator to prevent overcharging the battery.

NOTE - The repair of rectifiers integrated in the engine must be performed by a service centre authorised by the engine manufacturer, which has access to the information and parts needed for the checks and repairs.

7.2.8 Electromagnetic clutch

The electromagnetic clutch is used to connect or disconnect, via a switch, the equipment used on the machine. In addition, the clutch is designed to activate a brake on the output shaft, when it is disengaged.

The field coil is mounted to a bearing support and does not rotate.

The rotor is attached to the power output shaft and rotates around the field assembly.

The armature is connected to the output pulley.

The armature unit is assembled close to the brake unit rotor. The clutch is engaged by applying current to the coil connection.



This results in a current flowing through the coil, magnetizing the coil pulling the armature onto the rotor with sufficient force to hold the two pieces together, connecting the output and the input shafts firmly together.

The force of the armature against the rotor pulls it away from the brake, hence releasing the brake.

7.3 FUNCTIONAL CHECKS

7.3.1 General system checks

Make sure all switches are in the correct ignition position: :

- 1) PTO disengaged;
- 2) Hydrostatic transmission in "neutral";
- 3) Operator seated.
- 4) Parking brake engaged.

If there is no voltage supply to the battery to start the engine, perform the checks as follows.

• Phase 1

Check the battery. Use a voltmeter to check the correct voltage. Replace the battery if necessary and/or charge to the correct level.

• Phase 2

Use a voltmeter to check for battery voltage on terminal (B) on the rear side of the ignition switch in the «OFF» position. If there is no battery voltage on terminal (B), check the battery connection and the fuse on the red wire.

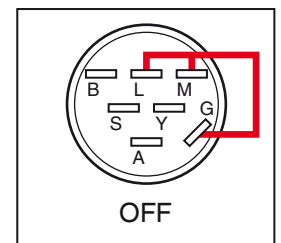

• Phase 3

With the ignition switch in the «RUN» position, check if the battery voltage is transferred from terminal (B) to terminal (A).

Terminal (A) on the ignition switch provides battery voltage to the rear of the PTO switch on the purple wire and to the "neutral" switches on the red/purple wire, to terminal S2 on the ignition switch and to terminal 85 on solenoid no. 2.

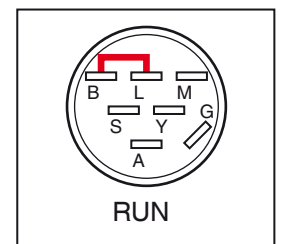

Terminal (A) also provides battery voltage to terminal 30 and 85 on solenoid no.1 and the hour counter.

When the operator is seated, the battery voltage transfers from terminal 30 to terminal 87, to the front terminal of the PTO switch and to terminal 85 on solenoid no. 2 on the yellow/red wire. The battery voltage is sent to the fuel shut-off solenoid valve from terminal 85 on solenoid no. 2.

• Phase 4

With the ignition switch in the «START» position, the battery voltage is transferred from terminal S2 to terminal 51.

Terminal 51 transfers the battery voltage to the the small ignition solenoid valve terminal and is grounded through the base of the starter motor solenoid valve.

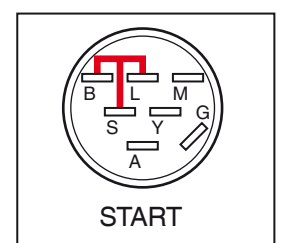

Manual activation of Normally Open Switches The contact resistance is 0.1-0.3 ohms when functioning correctly.

Ignition switch test. Check the battery voltage in the «OFF» position, test for voltage at terminal "B". There must be no voltage on terminals A, 51, S2. With the ignition switch in the «RUN» position, test for battery voltage at terminal B, A, S2. There must be no voltage on terminal 51.

PTO switch test. The PTO switch is a push/pull switch with normally open and closed contacts. Test for transfer of power with a voltmeter. The switch contacts should be tested using an ohmmeter after disconnecting the wiring connector.

Diode test. The diodes are tested with an ohmmeter set to diode testing. Voltage must travel in one direction only. If voltage travels in both directions or there is no voltage at all, the diode is faulty and must be replaced.

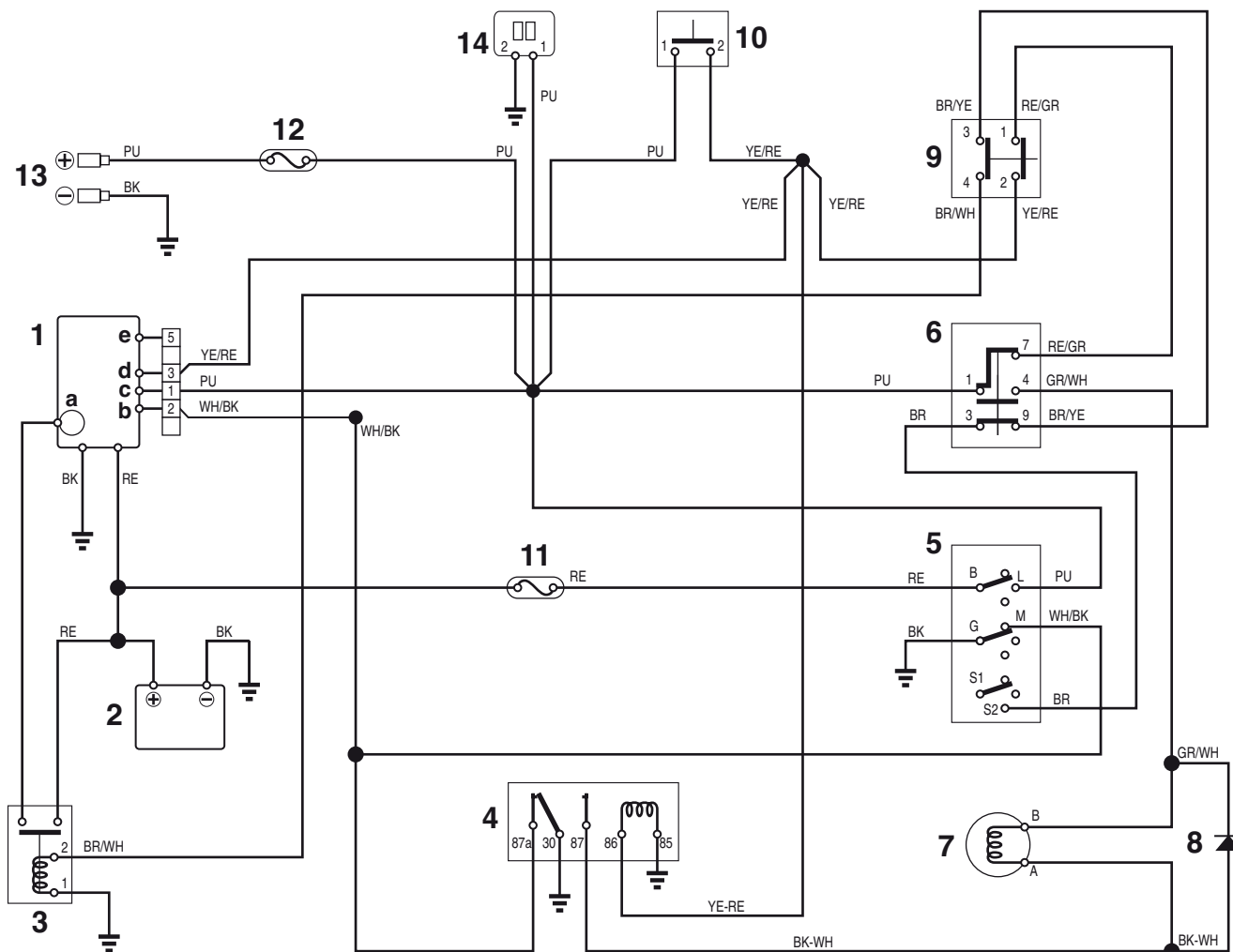
7.4 ELECTRICAL WIRING DIAGRAMS
7.4.1 Wiring layout

Components

1. Engine
 - a. Starter
 - b. Magneto kill
 - c. Regulator
 - d. Fuel solenoid
 - e. Oil pressure
2. Battery
3. Starter solenoid
4. Starter relay
5. Key switch
6. Blade switch (PTO)
7. Electromagnetic clutch
8. Diode
9. Parking brake switch
10. Seat switch
11. Fuse 30A
12. Fuse 15A
13. Aux Power
14. Hour meter

Colour Circuit

Black	Ground
Red	12 VDC Battery
Blue	Start
Green	PTO

Cable Color

BK	Black
BR	Brown
GR	Green
PU	Purple
RE	Red
WH	White
YE	Yellow

7.4.2 Operating layouts in user modes

a) Ignition key in the «OFF» position

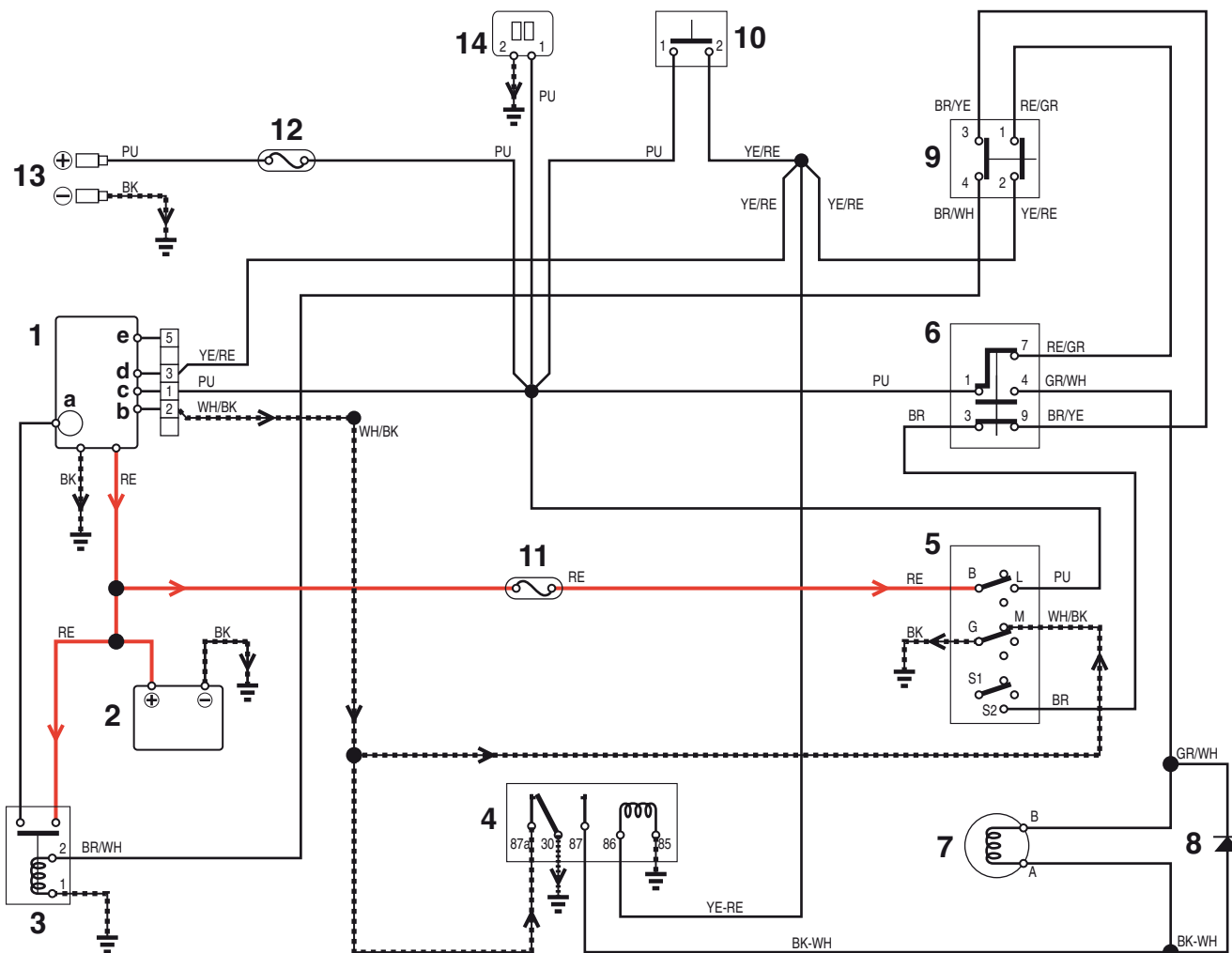

Components

1. Engine
 - a. Starter
 - b. Magneto kill
 - c. Regulator
 - d. Fuel solenoid
 - e. Oil pressure
2. Battery
3. Starter solenoid
4. Starter relay
5. Key switch
6. Blade switch (PTO)
7. Electromagnetic clutch
8. Diode
9. Parking brake switch
10. Seat switch
11. Fuse 30A
12. Fuse 15A
13. Aux Power
14. Hour meter

Colour Circuit

- | | |
|-------|----------------|
| Black | Ground |
| Red | 12 VDC Battery |
| Blue | Start |
| Green | PTO |

Cable Color

- | | |
|----|--------|
| BK | Black |
| BR | Brown |
| GR | Green |
| PU | Purple |
| RE | Red |
| WH | White |
| YE | Yellow |

b) Ignition key in the «RUN» position

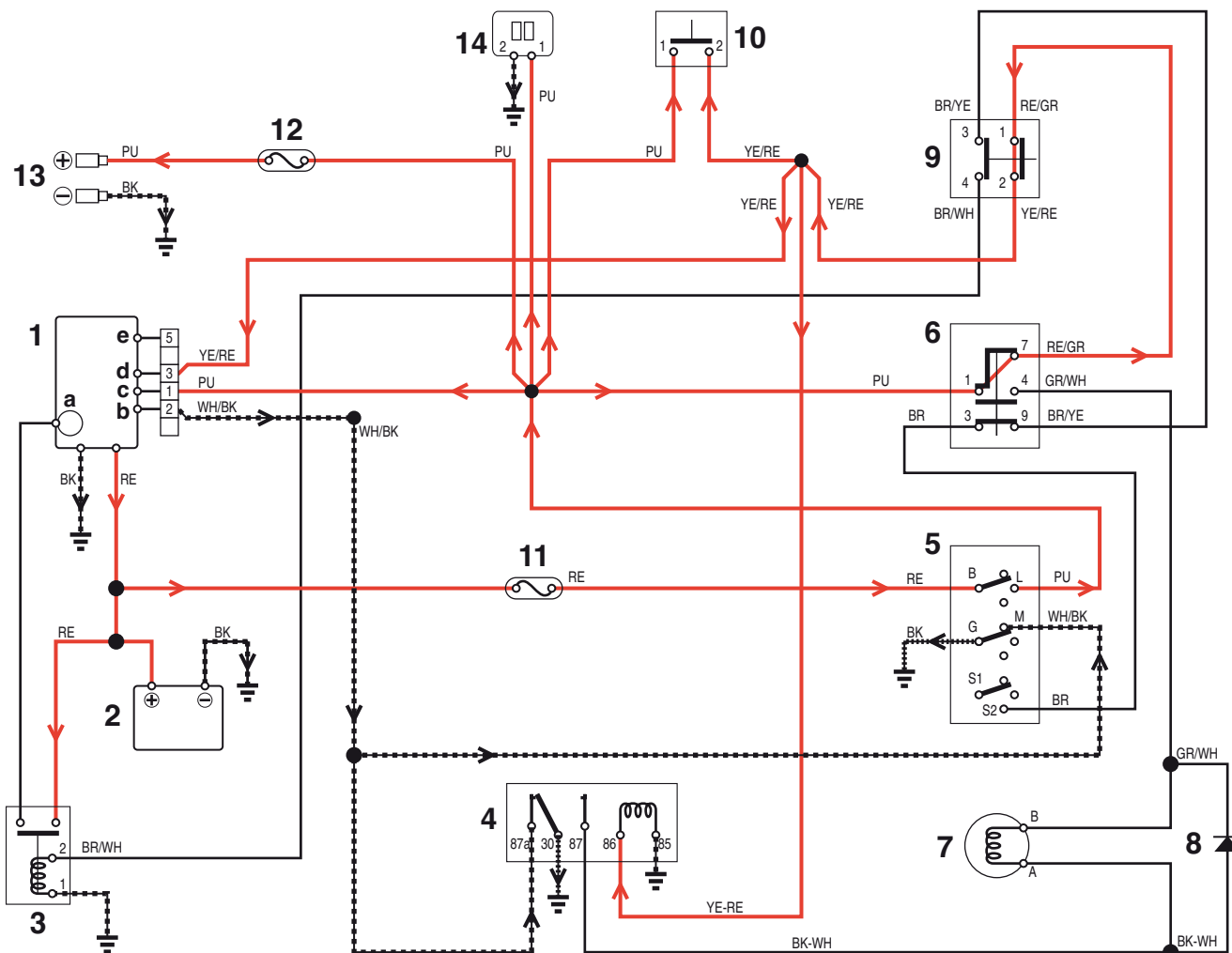

Components

- 1. Engine
 - a. Starter
 - b. Magneto kill
 - c. Regulator
 - d. Fuel solenoid
 - e. Oil pressure
- 2. Battery
- 3. Starter solenoid
- 4. Starter relay
- 5. Key switch
- 6. Blade switch (PTO)
- 7. Electromagnetic clutch
- 8. Diode
- 9. Parking brake switch
- 10. Seat switch
- 11. Fuse 30A
- 12. Fuse 15A
- 13. Aux Power
- 14. Hour meter

Colour Circuit

- Black Ground
- Red 12 VDC Battery
- Blue Start
- Green PTO

Cable Color

- BK Black
- BR Brown
- GR Green
- PU Purple
- RE Red
- WH White
- YE Yellow

c) Ignition key in the «START» position

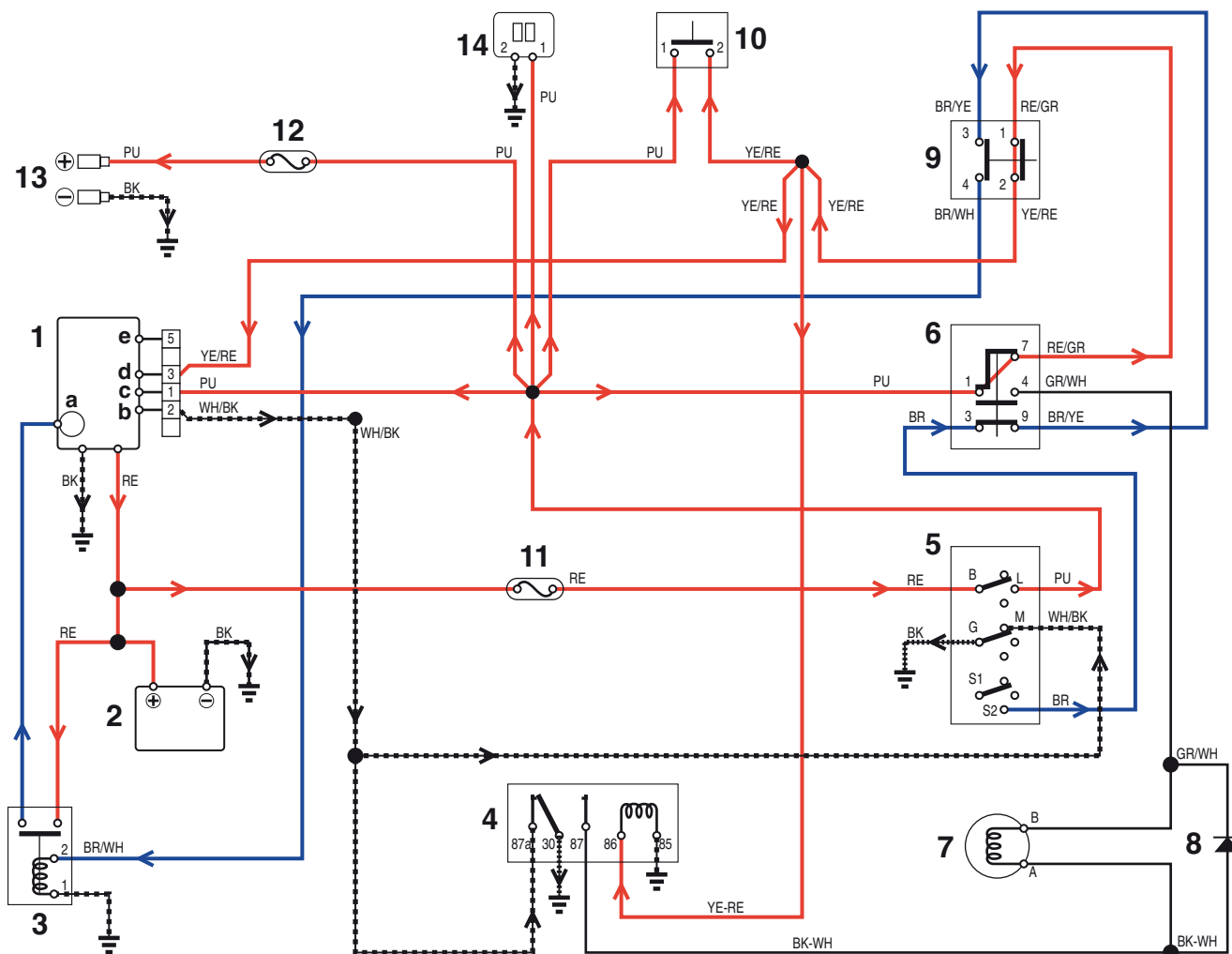

Components

- 1. Engine
 - a. Starter
 - b. Magneto kill
 - c. Regulator
 - d. Fuel solenoid
 - e. Oil pressure
- 2. Battery
- 3. Starter solenoid
- 4. Starter relay
- 5. Key switch
- 6. Blade switch (PTO)
- 7. Electromagnetic clutch
- 8. Diode
- 9. Parking brake switch
- 10. Seat switch
- 11. Fuse 30A
- 12. Fuse 15A
- 13. Aux Power
- 14. Hour meter

Colour Circuit

- Black Ground
- Red 12 VDC Battery
- Blue Start
- Green PTO

Cable Color

- BK Black
- BR Brown
- GR Green
- PU Purple
- RE Red
- WH White
- YE Yellow

d) Ignition key in the «RUN» position
Operator present / Parking brake disengaged

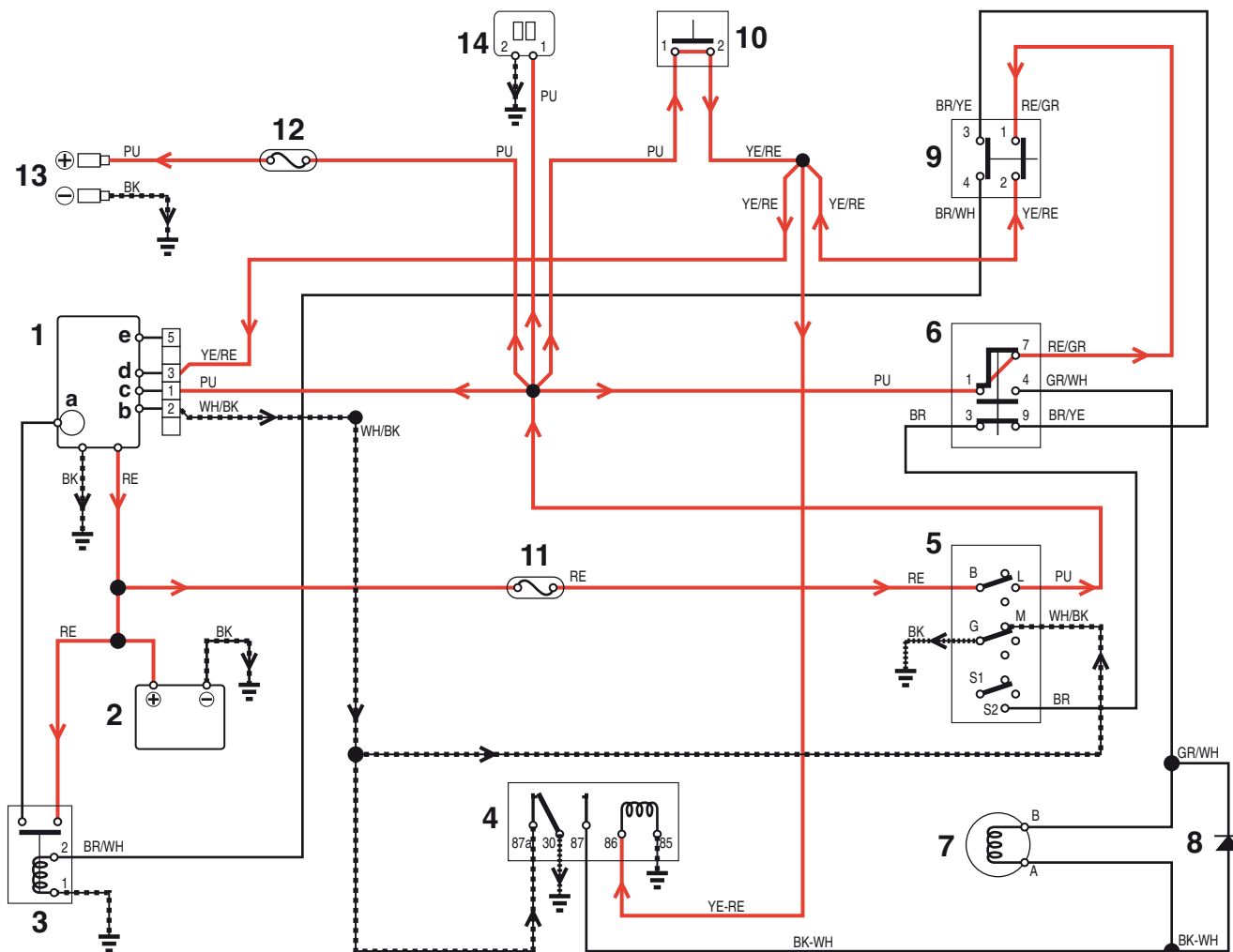

Components

- 1. Engine
 - a. Starter
 - b. Magneto kill
 - c. Regulator
 - d. Fuel solenoid
 - e. Oil pressure
- 2. Battery
- 3. Starter solenoid
- 4. Starter relay
- 5. Key switch
- 6. Blade switch (PTO)
- 7. Electromagnetic clutch
- 8. Diode
- 9. Parking brake switch
- 10. Seat switch
- 11. Fuse 30A
- 12. Fuse 15A
- 13. Aux Power
- 14. Hour meter

Colour Circuit

- Black Ground
- Red 12 VDC Battery
- Blue Start
- Green PTO

Cable Color

- BK Black
- BR Brown
- GR Green
- PU Purple
- RE Red
- WH White
- YE Yellow

e) Ignition key in the «RUN» position

Operator present / Parking brake disengaged / PTO blade engaged

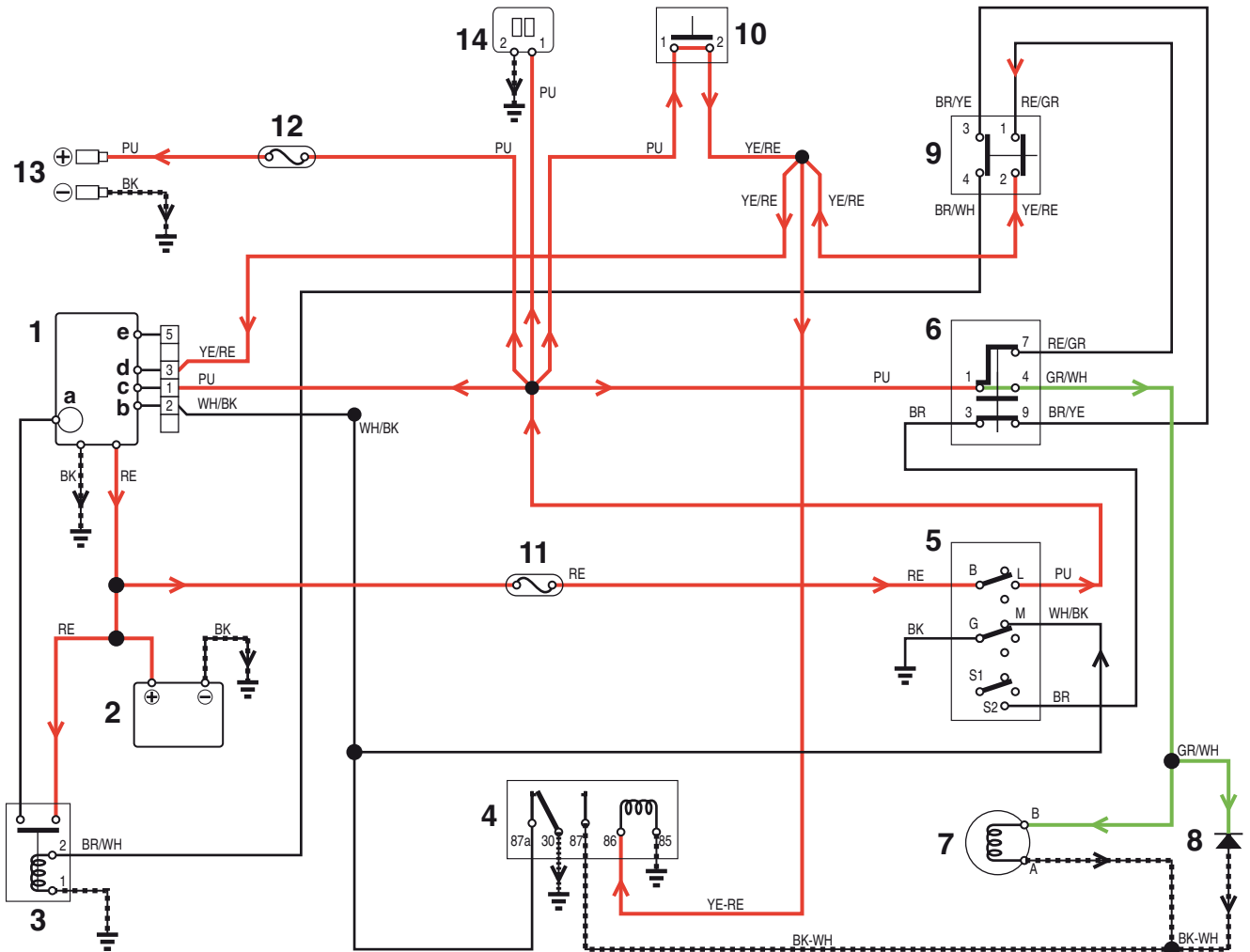

Components

- 1. Engine
 - a. Starter
 - b. Magneto kill
 - c. Regulator
 - d. Fuel solenoid
 - e. Oil pressure
- 2. Battery
- 3. Starter solenoid
- 4. Starter relay
- 5. Key switch
- 6. Blade switch (PTO)
- 7. Electromagnetic clutch
- 8. Diode
- 9. Parking brake switch
- 10. Seat switch
- 11. Fuse 30A
- 12. Fuse 15A
- 13. Aux Power
- 14. Hour meter

Colour Circuit

- Black Ground
- Red 12 VDC Battery
- Blue Start
- Green PTO

Cable Color

- BK Black
- BR Brown
- GR Green
- PU Purple
- RE Red
- WH White
- YE Yellow



STIGA S.p.A - Via del Lavoro, 6 - 31033 Castelfranco Veneto (TV) - Italy
www.stiga.com