

STIGA

TRE 224

WORKSHOP MANUAL

Rel. 0.0



PRODUCTION YEAR 2018-->....

The manufacturer reserves the right to make all the necessary technical or commercial improvements to its products, so there may be some differences between the series of engines and the contents of this manual. However the basic specifications and different operating procedures will remain the same.

by STIGA - No use of the illustrations or duplication, reproduction or translation, even partial, of the texts in this document may be made without explicit authorization.

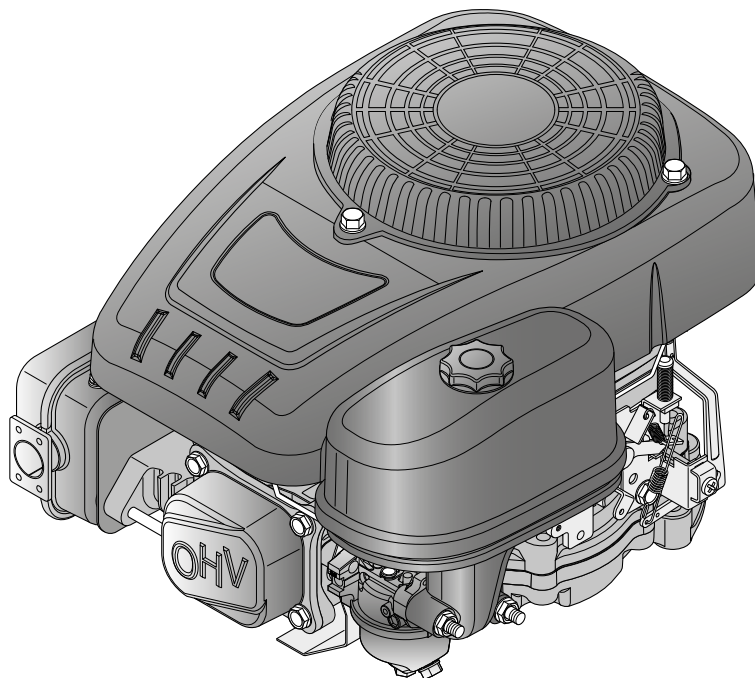

IMPORTANT NOTICE : The information contained herein is intended for Service Operations and professionals only, able to competently perform the operations described herein, using the appropriate equipment in order to safeguard se-curity and performance of the machine. The manufacturer is not liable for damages or injuries arising from operations performed by individuals or inadequate facilities.



CONTENTS

INTRODUCTION.....	5
1. RULES AND PROCEDURES FOR SERVICE CENTRES	6
1.1. Guarantee validity	6
1.2. Service repairs after guarantee period.....	6
1.3. Fault notification	6
1.4. Spare parts request.....	6
2. GENERAL AND SAFETY REGULATIONS.....	7
2.1. Qualification of operators	7
2.2. Safety measures	7
2.3. Precautions during servicing.....	7
2.4. Warning labels.....	8
2.5. Necessary equipment	8
2.6. Symbols and terms used for safety purposes.....	8
3. TECHNICAL DATA AND SPECIFICATIONS.....	9
3.1. Identification.....	9
3.2. Technical data	9
3.3. Adjustments	9
3.4. Expendable materials.....	9
3.5. Use limits.....	9
3.6. Tightening torques.....	10
3.7. Table of Tightening torques	11
3.8. Identification of engine units.....	12
4. ENGINE TUNING AND TESTING	13
4.1. Operating guidelines	13
4.2. Engine tuning program	13
4.3. Functional test	14
5. SUPPLY SYSTEM	15
6. STARTING SYSTEM.....	16
6.1. Removing the starter motor.....	16
6.2. Disassembly and cleaning the starter motor pinion.....	17
7. INTAKE SYSTEM	18
7.1. Maintenance of filtering element	18
8. CARBURATION.....	21
8.1. Removing and cleaning the carburettor.....	21
8.2. Replacing the carburettor	24
8.3. Adjusting minimum speed	24
8.4. Adjusting maximum speed	24
8.5. Adjusting the carburation.....	24

CONTENTS

9. GOVERNOR SYSTEM OF THE CARBURETTOR	25
9.1. Adjusting of accelerator cable	25
9.2. Adjusting maximum speed	26
9.3. Replacing the lever support.....	27
10. AUTO-CHOKE SYSTEM.....	28
10.1. Replacing of the AUTO-CHOKE system.....	28
11. IGNITION.....	29
11.1. Checking the efficiency of the ignition system	29
11.2. Adjusting the air gap and checking the coil	30
11.3. Replacing the coil.....	31
12. TURNING OFF AND STOPPING THE ENGINE	32
13. EXHAUST SYSTEM.....	33
13.1. Removing and replacing the muffler	33
14. ENGINE BLOCK - External operations	34
14.1. Checking the compression.....	34
14.2. Adjusting the valve clearance	35
14.3. Dismantling and cleaning the cylinder head	36
14.4. Overhauling the cylinder head and valves	37
14.5. Dismantling and replacing the magneto flywheel.....	39
14.6. Alternator removal and replacement.....	40
14.7. Checking the oil breather	40
14.8. Replacing the upper compression ring of the engine shaft (flywheel side)	41
14.9. Replacing the lower compression ring of the engine shaft (sump side).....	41
15. ENGINE BLOCK - Overhauling internal parts.....	43
15.1. Carter opening	43
15.2. Dismantling and checking the camshaft and counterweight governor.....	44
15.3. Dismantling and checking the piston, piston rings, connecting rod and engine shaft.....	46
16. TROUBLESHOOTING	52

INTRODUCTION

The purpose of this manual is to provide to Service Centres the information necessary for a correct maintenance, dismantling and repair procedure for **engines TRE 224**.

Interventions on the engine must be performed in accordance with instructions in the following pages and with safety regulations in force in the country in which the engine is operated, and only by authorised and appropriately trained personnel.

In every manual page the following informations are described:

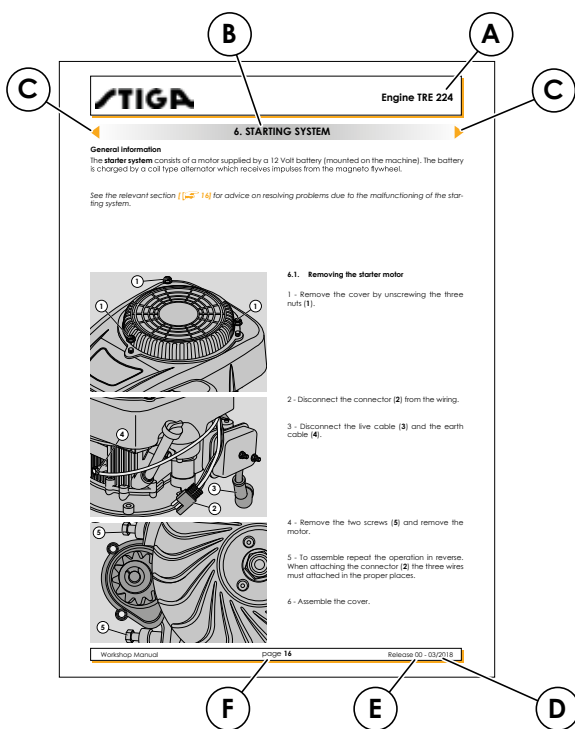

- A:** Motor typ for which the page is valid.
- B:** Reference to the chapter and the argument with the relative numbering.
- C:** Presence of previous or following chapters from the present chapter.
- D:** Issue date or possible audit.
- E:** Audit number.
- F:** Page progressive numbering.

Certain symbols are used in the manual, highlighting particularly important information, risks, warnings and prescriptions:

 **Warns of operations that should be carried out with utmost care to avoid impairing the functionality and safety of the lawnmower.**

 **Warns of operations that should be carried out with utmost care to avoid injury to the operator.**

 **NOTE: Refers to specific advice by the manufacturer.**

 **Reference to another procedure or part of the manual.**

 **Recommends that washers and O-rings are checked and replaced if necessary.**

 **Refers to use of special tools.**

 **Shows all the operations requiring different intervention methods depending on the engine version.**

 **NOTE: During the description of procedures, the indications "right", "left", "front", "rear", "upper" and "lower" refer to the engine mounted on the machine seen from the user's perspective.**

Please read all the contents of this manual to become familiar with the basics of the engine, which is fundamental for operating in a logical manner without making errors or wasting time.

1. RULES AND PROCEDURES FOR SERVICE CENTRES

1.1. Guarantee validity

The warranty is supplied under the terms, procedures and limits stated in the contract.

1.2. Service repairs after guarantee period

The Service Centre must write a report for each intervention containing the serial number of the engine  **3.1**, and summary information about the problems complained of, the intervention made and possible spare parts used.

A copy of these reports must be kept and made available to the manufacturer together with the replaced parts, in case clients should make further complaints.

1.3. Fault notification

The manufacturer should be informed of all faults that recur frequently; this allows it to carefully examine the problem and make corrections on the production line.

Similarly, the manufacturer shall report any faults traced on its engines, indicating the best troubleshooting procedure.

1.4. Spare parts request

When asking for spare parts, you must quote their code by referring to the exploded views corresponding to the year of manufacture reported on the nameplate  **3.1**.

2. GENERAL AND SAFETY REGULATIONS



IMPORTANT: Before commencing with any intervention, carefully read the information provided in the present manual, in particular the following safety regulations.

2.1. Qualification of operators

All maintenance, disassembly and repairs must be carried out by expert mechanics who are familiar with all the accident prevention and safety regulations after reading through the procedures in this manual.

2.2. Safety measures

All the engines are built in conformity with the European safety regulations in force. To maintain initial safety levels in the long term, the Service Centre should take proactive measures by making checks whenever possible. Every time you are asked to service the engine (or the lawnmower on which it is installed), you should:

- check:
 - that the safety devices function correctly;
 - that the casings and protection covers have not been removed;
 - that the nameplates or specification labels have not been removed or made illegible, (as they form an integral part of the safety devices).
- also:
 - restore to proper working order any safety devices which have been manipulated or removed;
 - replace ineffective, damaged or missing guards and covers;
 - replace illegible labels;
 - do not carry out operations or modifications on the lawnmower or on the engine that could affect their performance or lead to an improper or different use from the one for which it has been designed and approved;
 - warn the customer that the failure to comply with the above points automatically voids the warranty and the responsibility of the manufacturer.

2.3. Precautions during servicing

As well as following the usual accident prevention regulations that apply to most repair shops, we recommend you:

- disconnect the spark plug cap before servicing;
- protect hands with suitable working gloves, especially when working near the cutting unit;
- check that you do not cause accidental petrol leaks or other losses;
- do not smoke when working on the tank or when handling petrol;
- do not inhale oil or petrol fumes;
- clean up all traces of spilt petrol immediately;
- test the engine in a well-ventilated environment or where there are adequate exhaust fume extraction systems;
- do not pollute the environment with oil, petrol or other waste and dispose of all waste in accordance with the laws in force;



Exhaust gas contains carbon monoxide, which is highly toxic, odourless and colourless. Avoid inhaling.

- perform tests on the engine in a well-ventilated environment or in the presence of adequate exhaust gas extraction systems.

2. GENERAL AND SAFETY REGULATIONS

2.4. Warning labels

On the canopy motor, in a immediately identification position, are some indication or prescription plates for the safety operator. The plates are as follows:

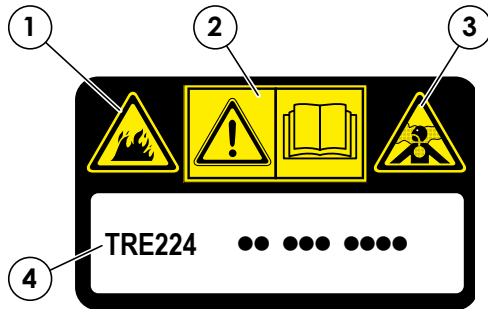

1 - Fire hazard due to:

- Petrol or oil

Prevent by following the precautions below:

- Do not smoke or ignite a flame in the vicinity of the petrol or oil;
- Turn engine off before adding petrol;
- Do not spill petrol on overheated or electric parts of the engine;
- Handle or store petrol or oil in well-ventilated areas;
- Use non-flammable oil for cleaning engine parts.

- Accumulation of flammable material

Prevent by following the precautions below:

- Remove dry leaves, chips, pieces of paper, dust or other flammable material which has accumulated in or is attached to the engine.

- Electrical cabling

Short circuits can cause fires. Prevent by following the precautions below:

- Always keep the electrical connections of the machine clean and tightly sealed;
- Tighten any loose connectors or cabling clamps. Replace those that are damaged.

2 - Observe the instructions and warnings contained in the present manual and on the safety plates on the engine.

Inappropriate functioning and maintenance can result in serious injury or even death.

3 - Ventilation of closed areas:

In the event that it is necessary to start the engine in a closed environment or if petrol or cleaning oil is being used, open doors and windows to ensure adequate ventilation and, therefore, avoid gas poisoning.

4 - Motor label (see  3.1)

2.5. Necessary equipment

All the operations can be carried out with the tools normally used in a good garage.

The , symbol used for certain interventions indicates that special tools or equipment are recommended.

2.6. Symbols and terms used for safety purposes

Some paragraphs in this manual are preceded by symbols which indicate the following:



Operations that should be carried out with utmost care to avoid impairing the functionality and safety of the engine and/or lawnmower on which it is installed.



Operations that should be carried out with utmost care to avoid injury to operators.

“WARNING” stresses the risk of injury to oneself and others if instructions and regulations are not observed.

3. TECHNICAL DATA AND SPECIFICATIONS

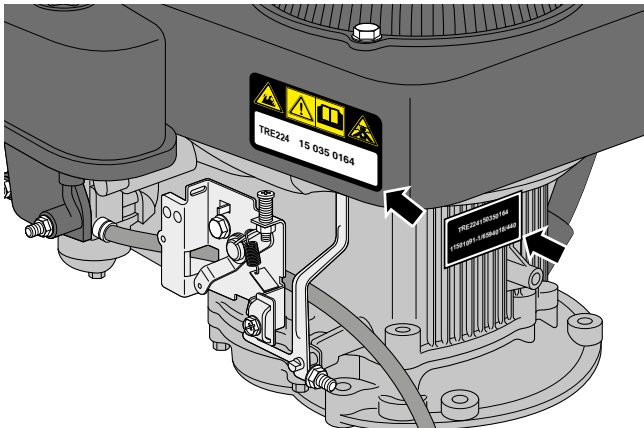

3.1. Identification

Every motor is marked with a serial number on the base and applied on the canopy; this serial number characters and can identify:

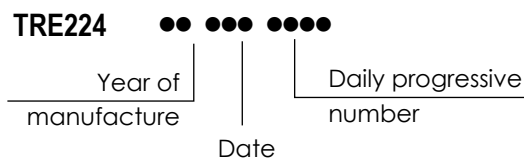

The serial number must be reported on every operating sheet in the warranty application and is fundamental for identifying and ordering spare parts.

3.2. Technical data

	TRE 224
Displacement	224 cc
Bore	75 mm
Stroke	51 mm
Compression ratio when new 8,3:1	Minimum 4 bar
Minimum speed (SLOW)	1800 (±150) r.p.m.
Maximum speed (FAST)	2800 (±100) r.p.m.
Oil sump capacity	0,5 litres
Dry weight	13,8 kg

3.3. Adjustments

Distance between spark plug electrodes	0,6 - 0,8 mm
Coil air gap	0,35 - 0,45 mm
Inlet valve clearance	0,10 - 0,15 mm
Exhaust valve clearance	0,15 - 0,20 mm

3.4. Expendable materials

		TRE 224
Petrol		Unleaded (green) minimum 90N.O.
Engine oil	- from 5 to 35 °C - from -15 to + 35°C	SAE 30 - 10W30
Spark plug		K7RTC or equivalent

3.5. Use limits

The following table gives the use limits of certain components subject to wear, after which the component must be replaced.

		TRE 224
Compression with de-compressor shut		0,8 Mpa (1300 r.p.m.)
Minimum inlet valve stem diameter		5,32 mm
Minimum exhaust valve stem diameter		5,27 mm
Minimum inlet valve head rim thickness		0,5 mm
Minimum exhaust valve head rim thickness		0,5 mm
Valve seat depth		2,0 mm
Minimum valve spring length		33,0 mm
Maximum gap between ends of cylinder rings		1,0 mm
Max. axial gap for compression rings		0,15 mm
Minimum gudgeon pin diameter		17,95 mm
Max. gudgeon pin-piston seat diameter		18,05 mm
Max. connecting rod diameter	gudgeon pin side	18,07 mm
	crank side	30,07 mm
Diam. connecting rod's pin on engine shaft		29,92 mm
Diameter aspiration cam		27,30 mm
Diameter discharge cam		27,45 mm
Diameter seat of camshaft		13,92 mm
Verify the engine shaft extremes		0,10 mm

3. TECHNICAL DATA AND SPECIFICATIONS

3.6. Tightening torques

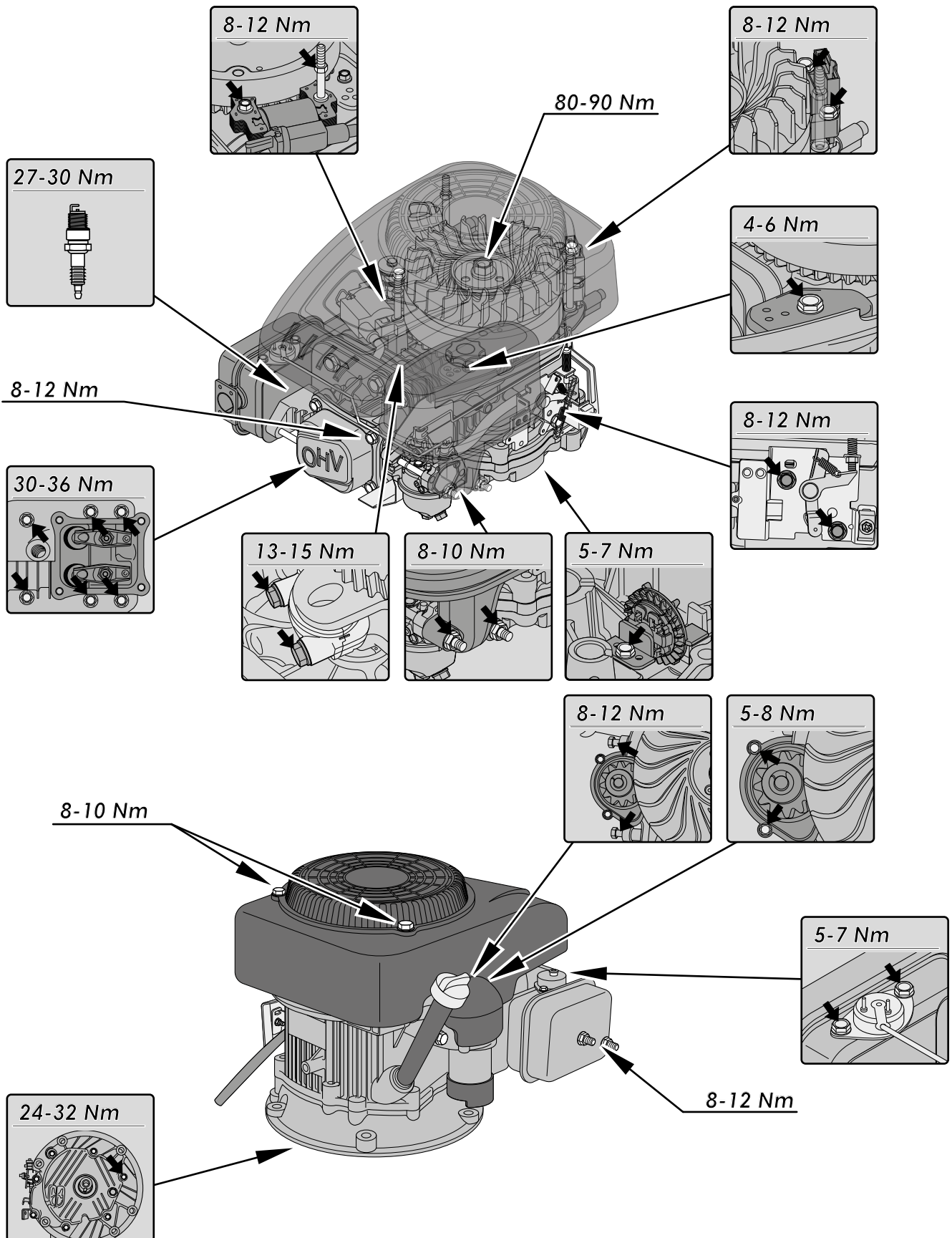

3. TECHNICAL DATA AND SPECIFICATIONS

3.7. Table of Tightening torques

Chapter Ref.	Description of screw	Tightening torques
6	Cover fixing nuts	8 - 10 Nm
6	Starter motor fixing screws	8 - 12 Nm
6	Starter motor screws	5 - 8 Nm
8	Carburettor and filter fixing nuts	8 - 10 Nm
9	Throttle support screws	8 - 12 Nm
10 - 13	Fixing screw AUTO-CHOKE	5 - 7 Nm
11 - 14	Spark plug tightening torque	27 - 30 Nm
11 - 14	Coil fixing screw	8 - 12 Nm
11 - 14	Coil fixing stud	8 - 12 Nm
13	Muffler fixing nuts	8 - 12 Nm
14	Valve cover fixing screws	8 - 12 Nm
14	Fixing head screws	30 - 36 Nm
14	Attachment bolt flywheel	80 - 90 Nm
14	Fixing screws generator	8 - 12 Nm
14	Pad plate screw	4 - 6 Nm
15	Union screws under carter and sump	24 - 32 Nm
15	Counterweight governor fixing screw	5 - 7 Nm
15	Fixing screws lower connecting rod cap	13 - 15 Nm

P.S. For the coupling torque of all standard screws refer to the single table.

3. TECHNICAL DATA AND SPECIFICATIONS

3.8. Identification of engine units

For ease of reference, this manual has subdivided maintenance operations into different sections, each of which refers to an engine component unit as indicated in the diagrams below.

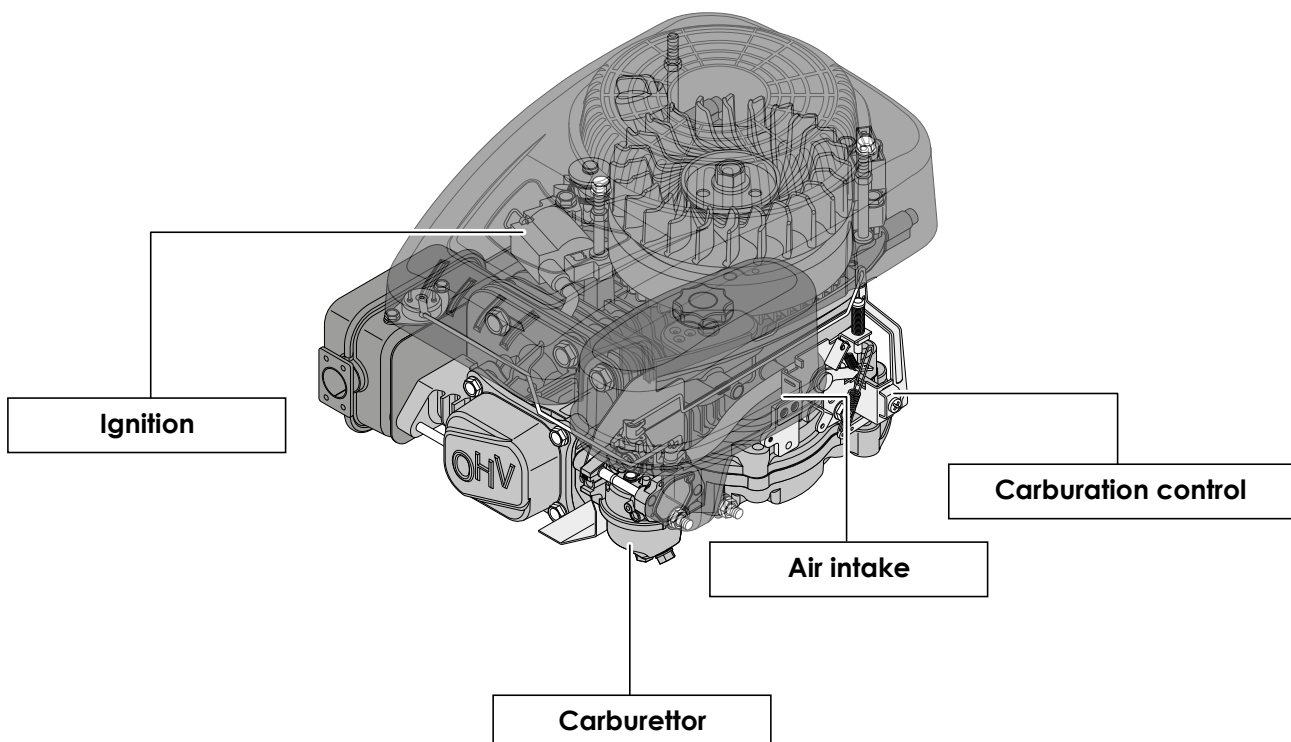
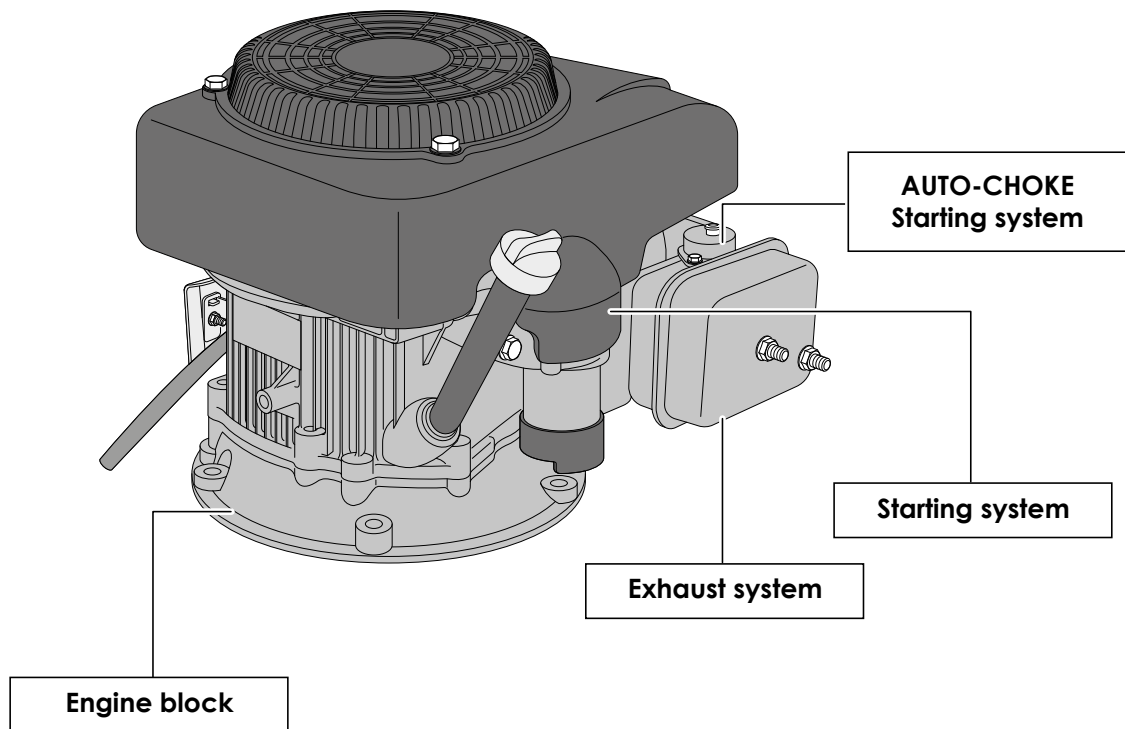

4. ENGINE TUNING AND TESTING

4.1. Operating guidelines



The engine requires a series of interventions (shown in the table below) in order to ensure minimum basic maintenance.

Operation	First 5 hours	Every 5 hours or daily	Every 50 hours or every season	Every 100 hours
Check oil level	-	■	-	-
Change oil ^{*(1)}	■	-	■	-
Clean muffler and engine	-	■	-	-
Check air cleaner ^{*(2)}	-	■	-	-
Replace air cleaner ^{*(2)}	-	-	■	-
Check spark plug	-	-	■	-
Replace spark plug	-	-	-	■
Fuel filter control	-	-	-	■

^{*(1)} Replace the oil every 25 hours if the engine is working at full load or at high temperatures.
^{*(2)} Clean the air filter more often if the machine is working in dusty areas.

For the operations that are not difficult for the final user the assistance centre must maintain the motor in perfect efficiency, in accordance with two intervention lines:

- Tuning the engine whenever possible.
- Recommending the client a routine maintenance program at set intervals (e.g. at the end of the season or before a long period of inactivity).



- inspecting the condition of the spark plug; checking the distance between the electrodes  11.1];
- tightening the screws;
- functional test  4.3].

Should the checks and adjustments fail to achieve a satisfactory result, refer to chapter  16] for troubleshooting.

4.2. Engine tuning program

As part of general engine tuning or any intervention on the machine, it is recommended that the Service Centre performs a series of operations aimed at maintaining the engine's efficiency.

Tuning should involve:

- external blowing and cleaning the cylinder head, cylinder and muffler by removing any remains of grass and mud;
- checking the oil level, topping up or replacing parts if necessary;
- cleaning the air filter  7.1];
- adjusting minimum and maximum speeds  8.3 and 9.2];

4. ENGINE TUNING AND TESTING

4.3. Functional test

A functional test needs to be carried out at the end of each servicing operation, to check that the operations made are effective. The test must be performed in compliance with the safety regulations regarding the use of the machine on which the engine is installed.

The functional test is carried out as follows:

a. Refuelling and checking the supply system

When you have refuelled the tank with new petrol, check the seal of the tank, the cap and the carburettor pipe.

b. Hot and cold starting test

The engine is equipped with intelligent starter system (AUTO-CHOKE), with the throttle in the "SLOW" position, perform some cold and hot starts to make sure they happen regularly.

c. Check the engine rpm

When the engine is hot enough, check the engine speed with the throttle control set to "SLO" and "FAST"; the readings should be equal to the specifications [ 3.2].

If all of these operations have a positive result, the engine can be considered fully serviceable and be returned to the client.

5. SUPPLY SYSTEM



IMPORTANT: Carefully read the information below before commencing any intervention.

General Information

The **fuel supply system** is via a tank installed on the machine connected to the carburettor by a pipeline; a filter between the tank and the fuel pump, prevents deposits and impurities from reaching the carburettor.

The supply to the carburettor float chamber is caused by gravity and the volume of petrol taken from the tank as the engine runs is compensated by a breather pipe in the cap.

See the relevant section  **16** for advice on resolving problems due to the malfunctioning of the petrol supply system.



WARNING: All interventions on the supply system must be performed in safe conditions, therefore:

- do not smoke;
- work in a ventilated environment away from naked flames or unprotected sources of heat;
- collect any remaining petrol by positioning a suitable container under the engine, avoiding soiling the work bench;
- remove all traces of spilt petrol immediately;

6. STARTING SYSTEM

General information

The **starter system** consists of a motor supplied by a 12 Volt battery (mounted on the machine). The battery is charged by a coil type alternator which receives impulses from the magneto flywheel.

See the relevant section [\[🔧 16\]](#) for advice on resolving problems due to the malfunctioning of the starting system.

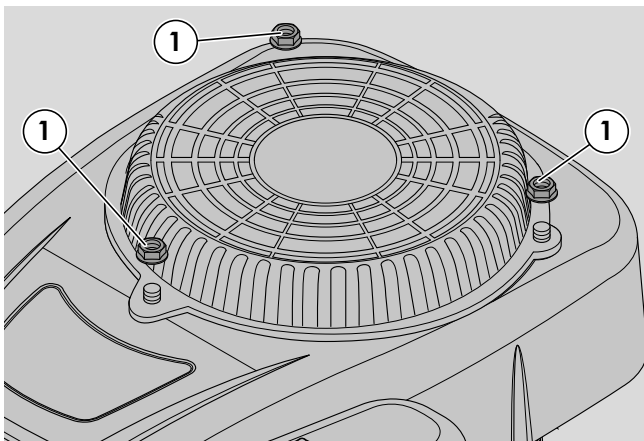

6.1. Removing the starter motor

1 - Remove the cover by unscrewing the three nuts (1).

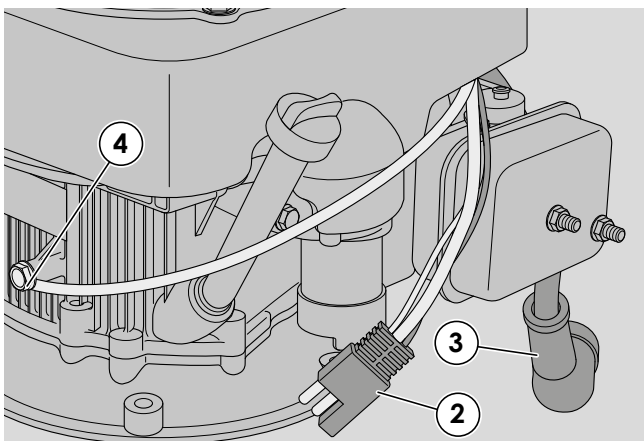

2 - Disconnect the connector (2) from the wiring.

3 - Disconnect the live cable (3) and the earth cable (4).

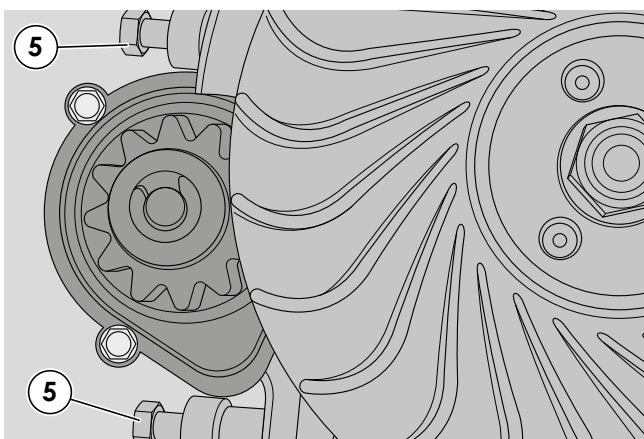

4 - Remove the two screws (5) and remove the motor.

5 - To assemble repeat the operation in reverse. When attaching the connector (2) the three wires must be attached in the proper places.

6 - Assemble the cover.

6. STARTING SYSTEM

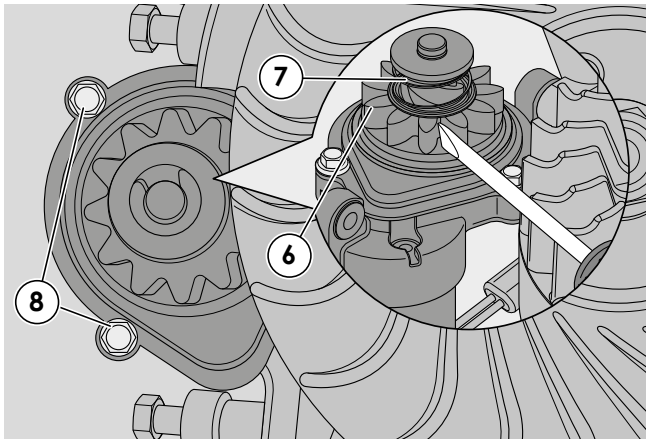

6.2. Disassembly and cleaning the starter motor pinion

1 - Remove the cover.

2 - Use a screwdriver to rotate the pinion (6) to check that it spins and moves co-axially and can compress the spring (7).

3 - In case the full movement is impeded by dirt:

- remove the dirt by using compressed air;
- spray with lubricant and repeatedly move the pinion;
- when the movement becomes smooth clean with compressed air;
- spray again with lubricant.

Avoid using grease or oil as it causes dirt to accumulate.

If the motor becomes noisy it should be replaced [🔧 6.1].

4 - Remove the pinion assembly by undoing the screws (8) and check the condition of the gears. (Replace the pinion assembly if there is any damage).

Tightening torques

1	Cover fixing nuts	8-10 Nm
5	Fixing screw starting motor	8-12 Nm
8	Starting motor screw	5-8 Nm

7. INTAKE SYSTEM

General information

The **intake system** uses an air filter directly connected to the carburettor by means of a manifold which conveys the air/petrol mixture to the inlet valve.

See the relevant section [👉 16] for advice on resolving problems due to the malfunctioning of the air intake system.

An inefficient filter can let dust or debris enter the cylinder, causing premature wear to the piston rings and cylinder.

The air filter is found on the left hand side of the engine and can be inspected without having to remove other parts.

The filter assembly is to be removed only to accede the carburettor.

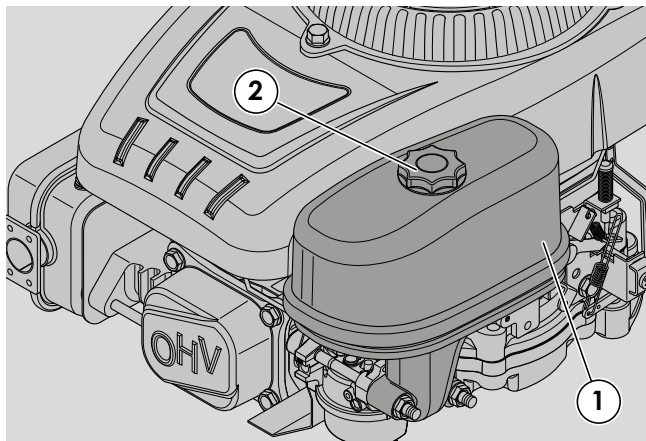

7.1. Maintenance of filtering element



WARNING: Never run the engine without air filter. The engine would certainly be damaged.

1 - Clean the area around the filter cover (1) by blowing it with compressed air.

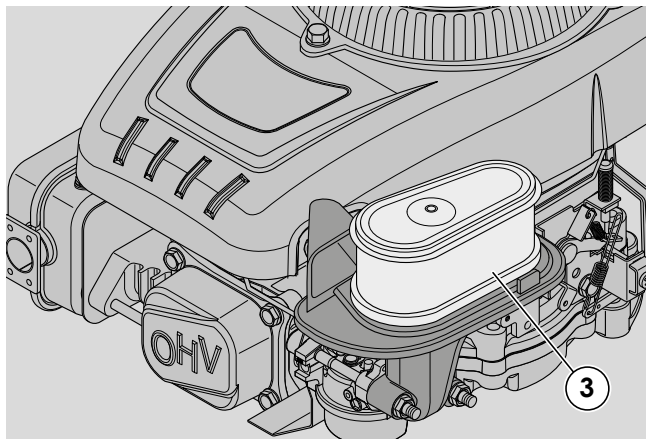

2 - Remove the cover plate (1) by turning the dedicated knob (2) and remove the filter element (3).

3 - Check carefully that the element has no holes or tears, and replace it if it is damaged.

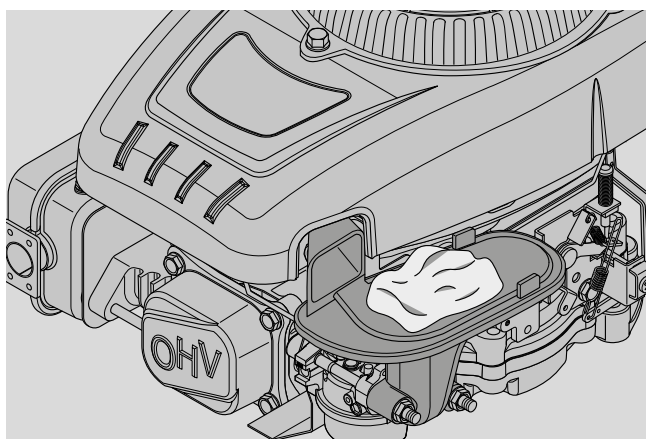

WARNING: When the filter element is removed the intake duct should be covered to avoid foreign bodies from entering. (see the figure).

7. INTAKE SYSTEM

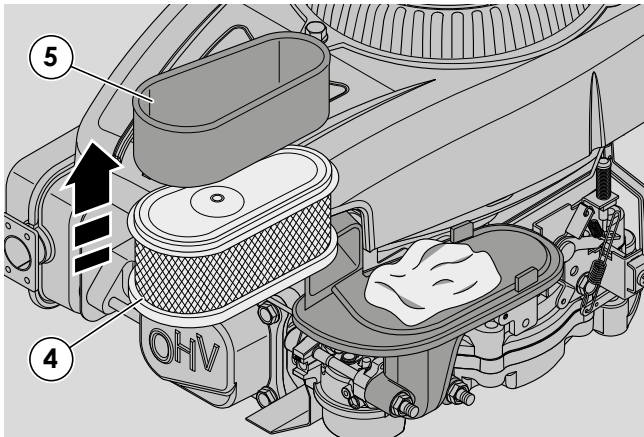

4 - Remove the filter element (4) and remove the prefilter (5) from the cartridge.

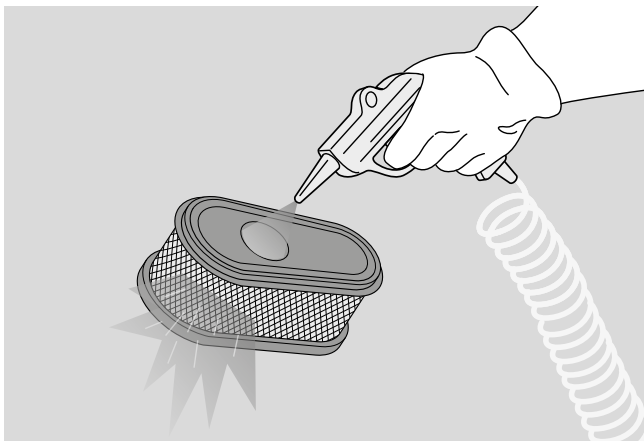

5 - Beat the cartridge on a solid surface and blow with compressed air from the interior side to remove dust and product residues.



IMPORTANT : For the cartridge cleaning don't use water, petrol, detergent.

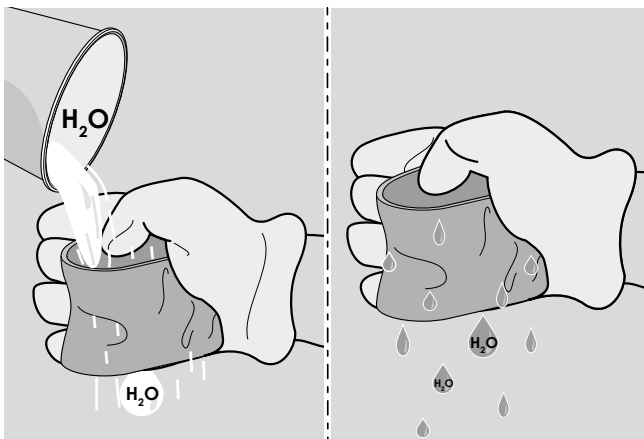

6 - Wash the prefilter with water and detergent and let it air dry.



IMPORTANT : the prefilterer **MUST NOT** be oiled.

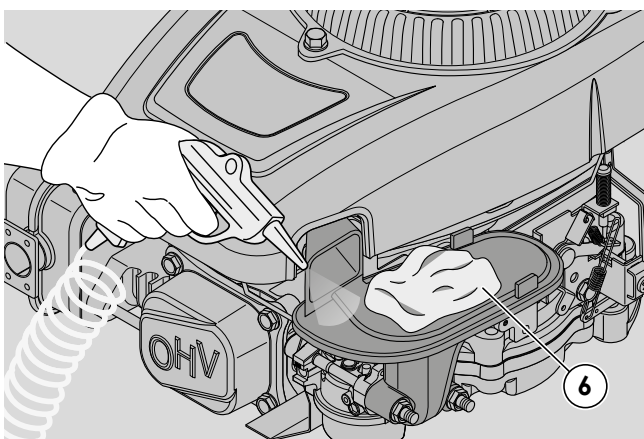

7 - Refit the prefilter (5) on the cartridge.

8 - With a jet of compressed air, clean inside the seat (6) of the filter by removing dust and remains of grass.

7. INTAKE SYSTEM

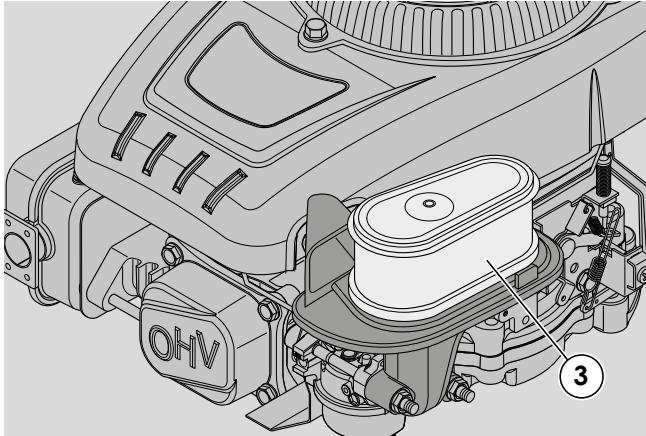

9 - Reassemble in their seats the filter element (3) and its cover plate (1) by turning the dedicated knob (2).

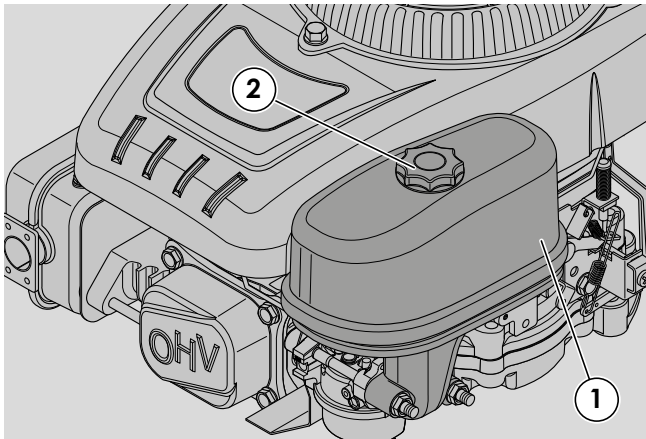

8. CARBURATION

General information

The **carburettor** has a float with a fixed jet and a "AUTO-CHOKE" control.

See the relevant section [🔧 16] for advice on resolving problems due to carburation.

The carburettor is located on the left-hand side of the engine. For maintenance operations it is necessary to dismantle the air intake filter in the sequence shown below.

Some of the following operations can be facilitated by removing the engine from the machine.



NOTE: For engine removal operations you should consult the manual specific to the machine on which the engine itself is mounted.

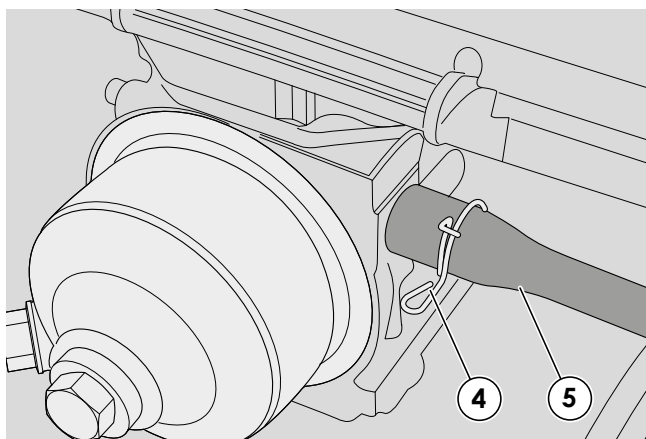
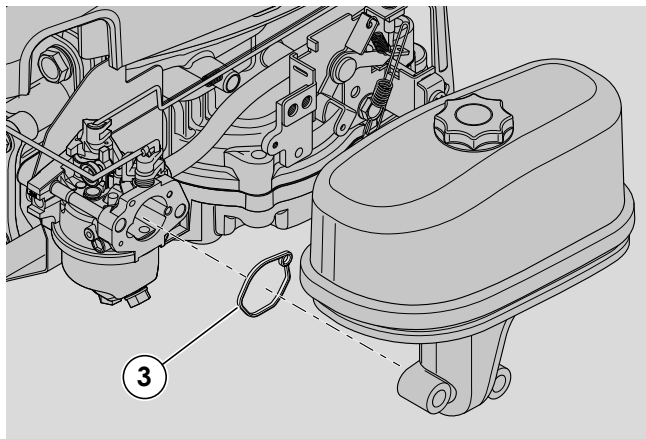
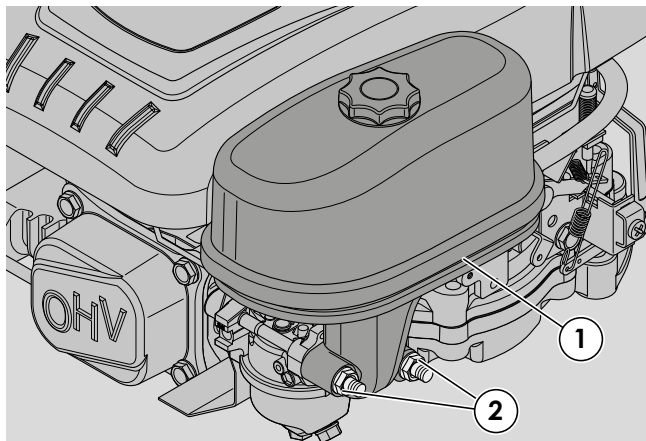

WARNING! All operations on the tank and supply system must be carried out in safe conditions, so:

- do not smoke;
- always empty the tank if petrol is not strictly necessary for the operation to be carried out;
- work in a ventilated environment away from naked flames or unprotected sources of heat;
- collect petrol in a suitable container with a cap using a funnel and avoid spilling it on the work bench;
- remove all traces of spill petrol immediately;
- check you have connected the pipes before pouring petrol back into the tank.

8.1. Removing and cleaning the carburettor

1 - Remove the complete filter (1) by unscrewing the nuts (2).

Retrieve and verify the integrity of the silicone gasket (3) and if necessary replace it.

2 - Remove the clamp (4) for the petrol pipe (5) from the side of the carburettor and use a suitable container to collect all the petrol in the tank and the pipe.

8. CARBURATION

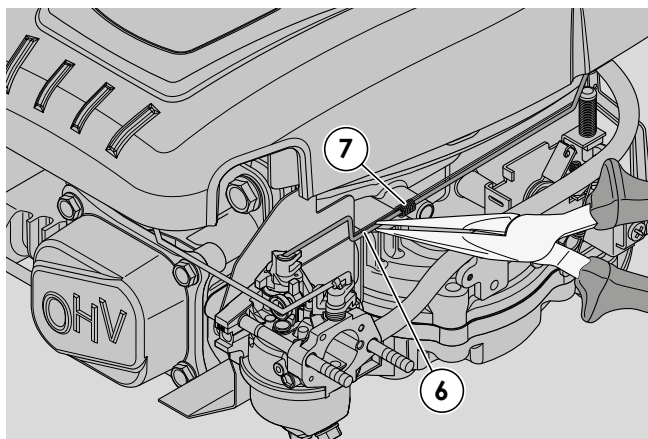

3 - Bring to a minimum the intake butterfly shaft. Using pliers remove the intake butterfly shaft (6) and pull up its compensation spring (7).

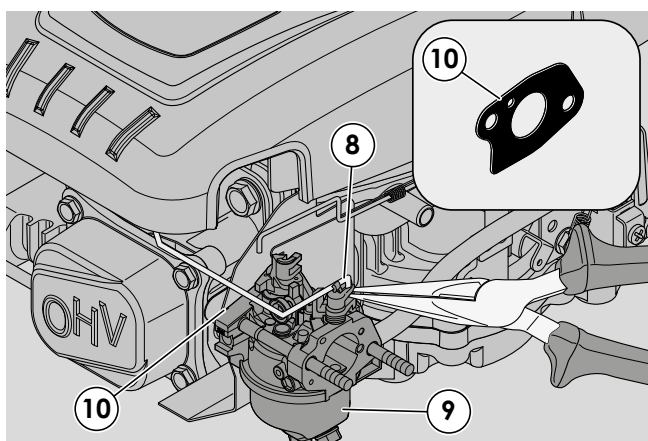

4 - Using pliers remove the tie rod (8) of the AUTO-CHOKE lever and remove the carburettor (9) and the gaskets (10) which will be replaced when re-assembling.

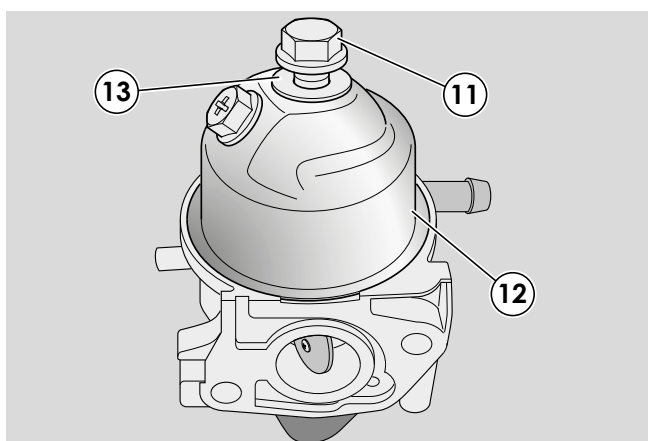

5 - Loosen the central screw (11) fastening the float chamber (12) remove the relative gasket (13) and carefully collect all the petrol left in the float chamber.

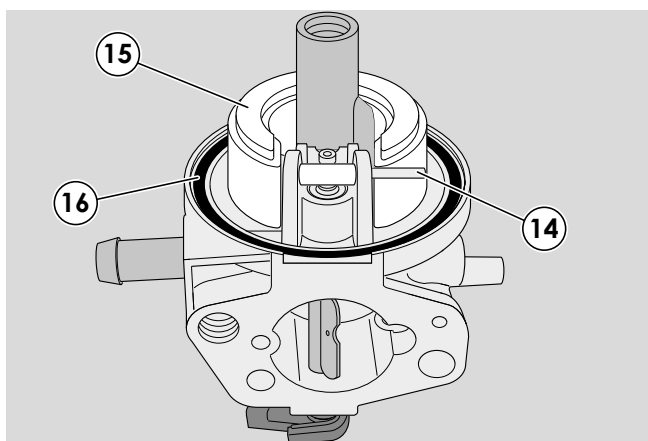

6 - Pull out the pin (14), dismantle the float (15) and remove the gasket (16).

8. CARBURATION

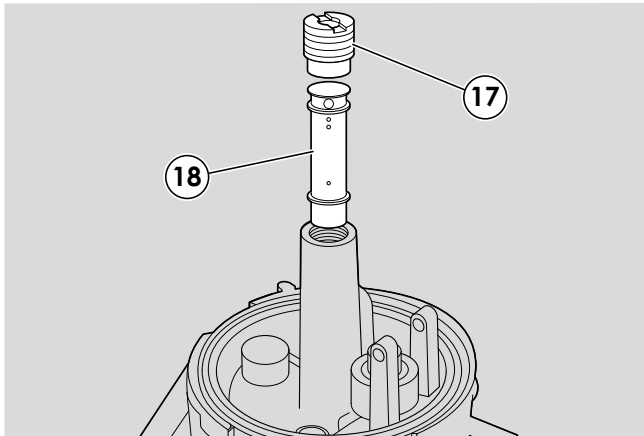

7 - Undo the main jet (17) and pull out the pilot jet (18).

8 - Check that no impurities or dirt are deposited in the seat of the needle (19) and of the pilot jet. **Verify that the rubber tip of the needle is not marked or worn.**

9 - Clean the carburettor (9) the main jet (17) and the pilot jet (18) thoroughly by immersing them in clean petrol (or a detergent) for 24 hours. Dry with compressed air, blowing well through the carburettor holes.

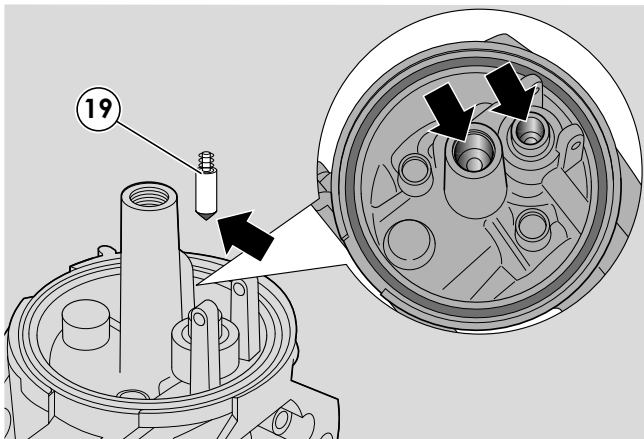

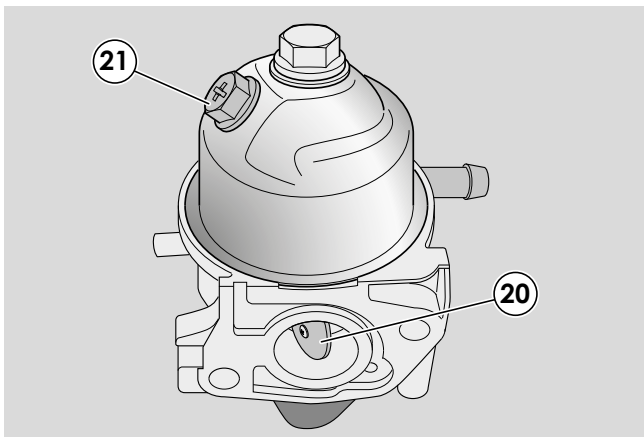

10 - Mount the carburettor following the previous points 6, 5 and 4 in reverse order, remembering that:

-  It is always advisable to replace the washer (16) and the gasket (13) of the float chamber;
- the float (15) must oscillate freely on the pin (14);
- the jet (17) should never be modified or replaced with others even if they seem to have the same specifications;
- the AUTO-CHOKE (20) must open and close regularly;
- the float chamber drain screw (21) must be facing forwards.



11 - Remount all linkage and checking that the governor system moves smoothly without stopping.

12 -  Always replace washers (10) when remounting the carburettor onto the engine.

13 - Assemble the whole filter (1) and fasten its nuts (2) to the specified torque. Refit the filter element [ 7.1].

8. CARBURATION

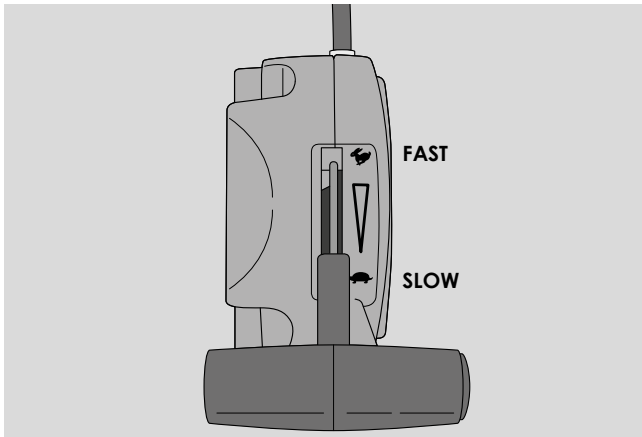

8.2. Replacing the carburettor

1 - Perform operations 1 - 2 - 3 - 4 - 10 - 11 - 12 indicated in section [\[🔧 8.1\]](#) above.

8.3. Adjusting minimum speed

1 - Check that the throttle cable is adjusted correctly [\[🔧 9.1\]](#).

2 - Let the engine heat up for a few minutes, then set the throttle control to "SLOW".



Check the rotation speed on the speed indicator (22).



NOTE: The engine's minimum speed must be between 1800 (±150) rpm.

3 - Turn the screw (23) until you achieve a stable minimum speed within the above values.

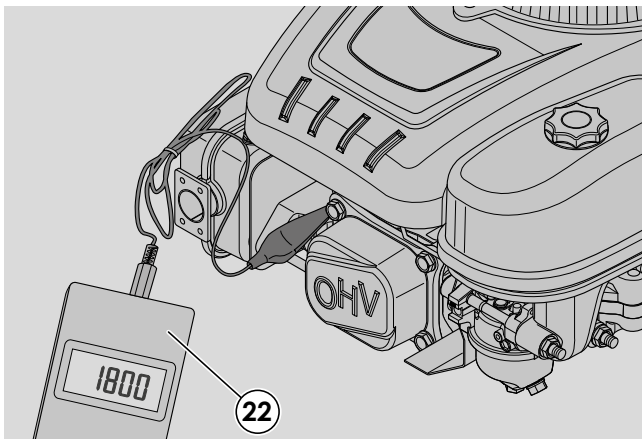
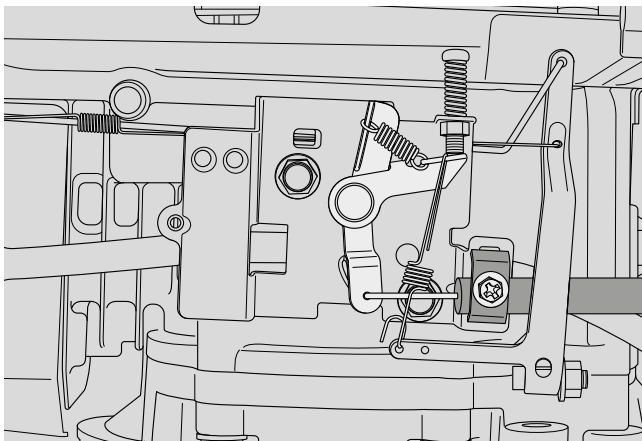

8.4. Adjusting maximum speed



NOTE: This operation is carried out by adjusting the governor system [\[🔧 9.2\]](#).

8.5. Adjusting the carburation



NOTE: The carburation is set in the factory and does not normally need changing. In the event of irregular functioning, clean the carburettor as indicated in section [\[🔧 8.1\]](#).

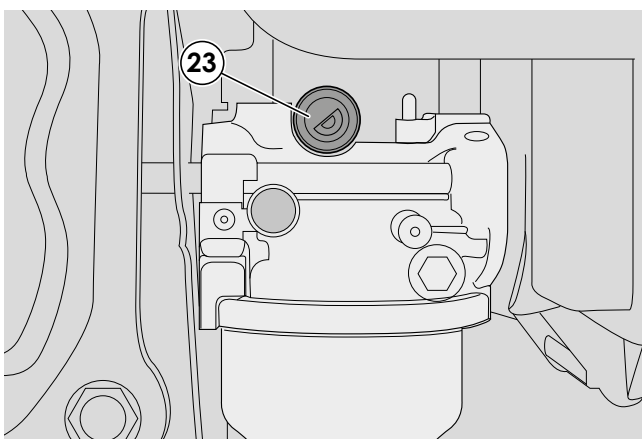

Tightening torques

2 Carburettor nuts/filter 8-10 Nm

Technical information

Minimum speed (SLOW) 1800 (±150) rpm

Special equipment

22 Speed indicator

9. GOVERNOR SYSTEM OF THE CARBURETTOR

General information

The **carburettor governor system** uses an engine shaft linkage fitted on a support fixed to the left-hand side of the engine, completed by a counterweight device, driven by the camshaft, and thus sensitive to changes in the engine's revolution pattern depending on load.

The force of the counterweights, transferred to the control lever, tends to shut the main carburettor butterfly, in opposition with the spring that would keep it open; the balance between the spring loading and the thrust of the counterweights on the control lever modifies the butterfly opening and adapts the flow of fuel to the engine so that the revolution speed is kept constant with engine load changes.

See the relevant section [\[🔧 16\]](#) for advice on resolving problems related to the governor system.

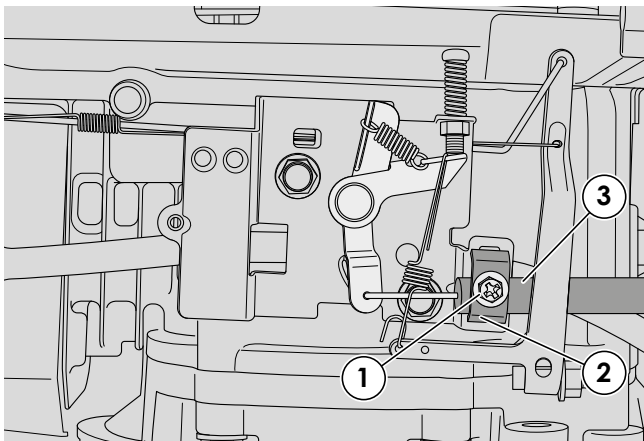

9.1. Adjusting of accelerator cable

1 - Loosen the screw (1) of the clamp (2) so that the cable casing (3) is free to move.

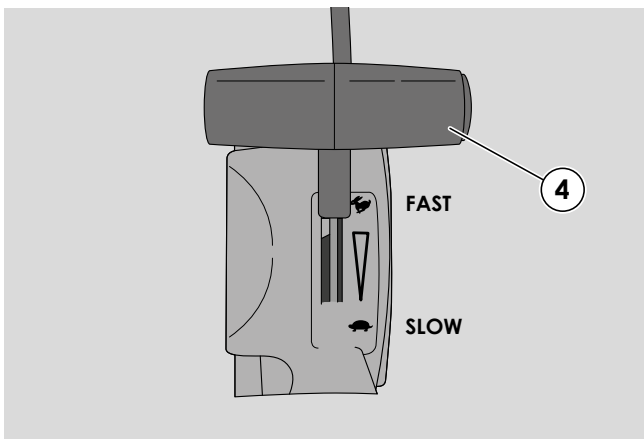

2 - Set the throttle control lever (4) to "FAST".

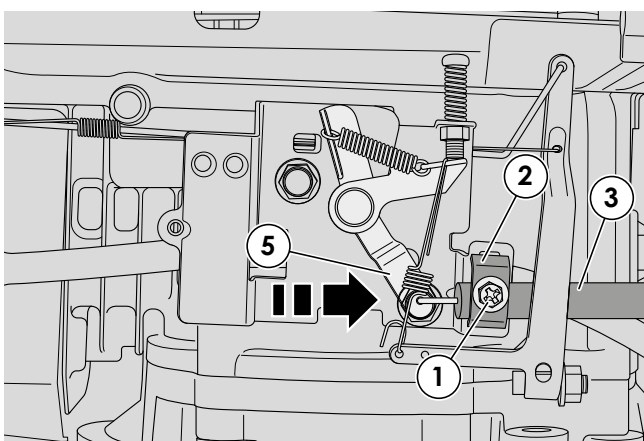

3 - Move governor control lever (5) forward as far as possible and, by keeping it in this position, lock the casing (3) full tightening the screw (1) of the clamp (2).

9. GOVERNOR SYSTEM OF THE CARBURETTOR

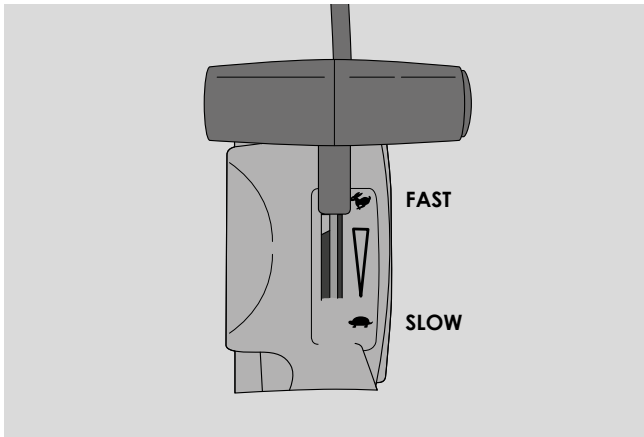

9.2. Adjusting maximum speed

1 - Check that the throttle cable is adjusted correctly [9.1].

2 - Let the engine heat up for a few minutes then set the throttle control to "FAST".

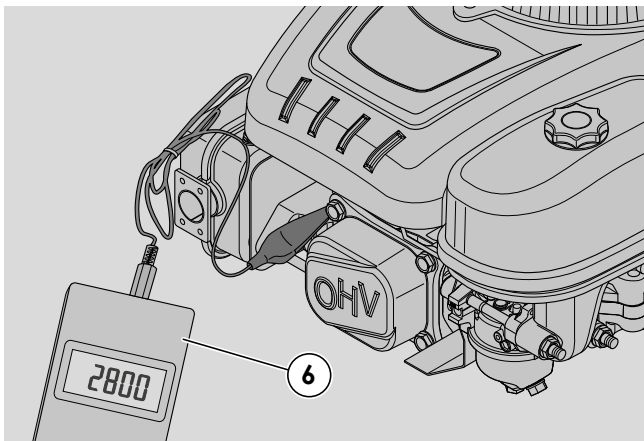

3 - Check the rotation speed on the speed indicator (6).

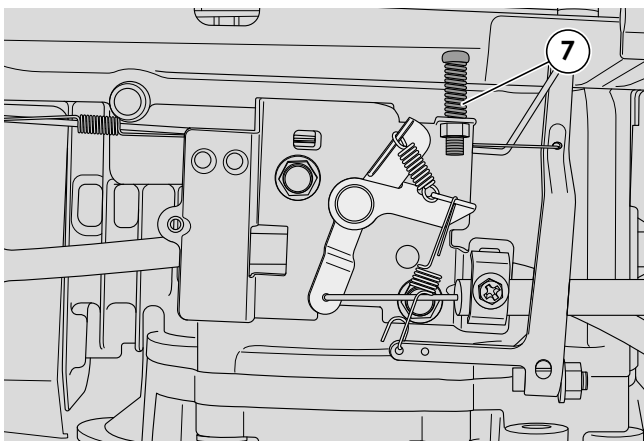

4 - Act on the regulation screw (7) to establish the correct value of the maximum turn system.

NOTE: The engine's maximum speed must be between 2800 (± 100) rpm; if you do not read this value, proceed as follows.

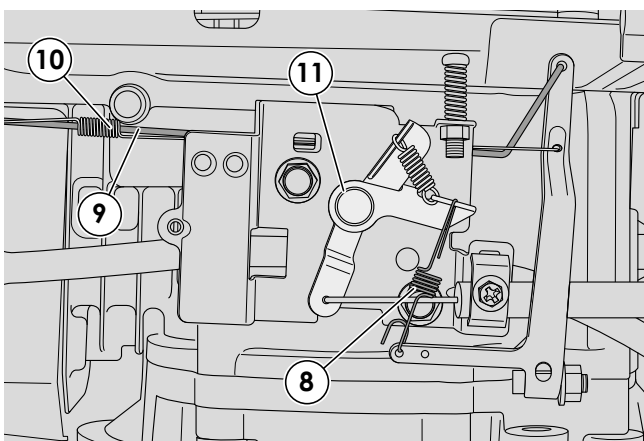

5 - Check:

- that the spring (8) is intact and positioned at the attachment point furthest from the fulcrum of the control lever;

- that the wire (9) and the relative spring (10) are intact and not deformed;

- that the moving levers (11) are not bent or deformed and replace the entire support if necessary [9.3].

9. GOVERNOR SYSTEM OF THE CARBURETTOR

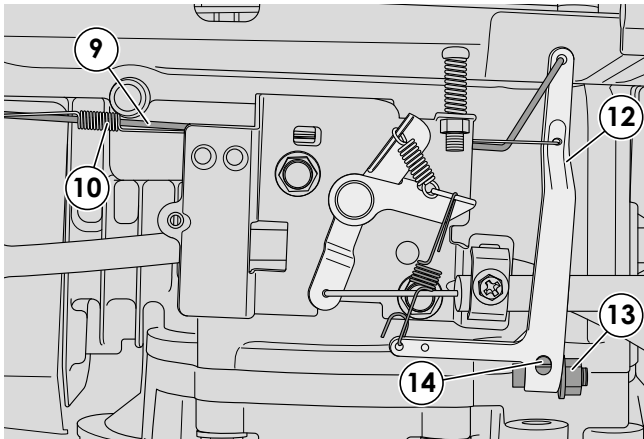

6 - If the above checks do not show any faults, the phasing of the governor's control lever (12) with respect to the counterweight device must be checked:

- stop the engine and move the accelerator control to "FAST";
- slacken off the control lever (13) locknut (12);
- without changing the lever (12) position determined by the spring (10) and tie-engine shaft (9), use a screwdriver to turn pin (14) clockwise to the end of its stroke and then lock the nut (13).

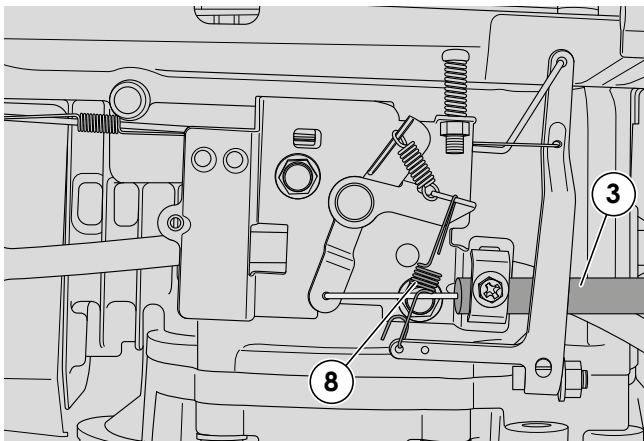

9.3. Replacing the lever support

1 - Position the accelerator lever to minimum ("SLOW" position).

2 - Remove the carburettor [[👉 8.1].

3 - Disconnect the accelerator cable (3) and the spring (8).

4 - Undo the two screws (15) securing the support (16) to the engine.

5 - Perform the above operations in reverse order when assembling.

6 - Refit the carburettor [[👉 8.1].

7 - Adjust the maximum speed [[👉 9.2].

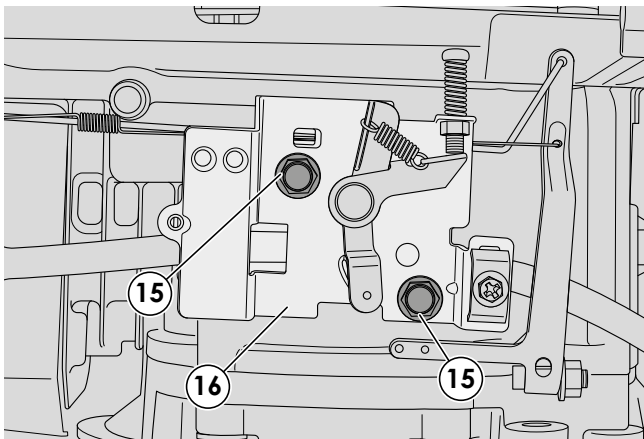

Tightening torques

15 Throttle support screws 8-12 Nm

Technical information

Maximum speed (FAST) 2800 (±100) rpm

Special equipment

6 Speed indicator

10. AUTO-CHOKE SYSTEM

General information

The smart starter system (AUTO-CHOKE System) is a mechanism sensitive to temperature variation that adjusts the starter's throttle valve, ensuring immediate and proper starting and operating of the engine automatically.

The **AUTO-CHOKE system** assembled on the exhaust unit employs a lever connected to the adjusting pin of the second throttle valve.

See the relevant section [ 16] for advice on resolving problems related to the AUTO-CHOKE system.

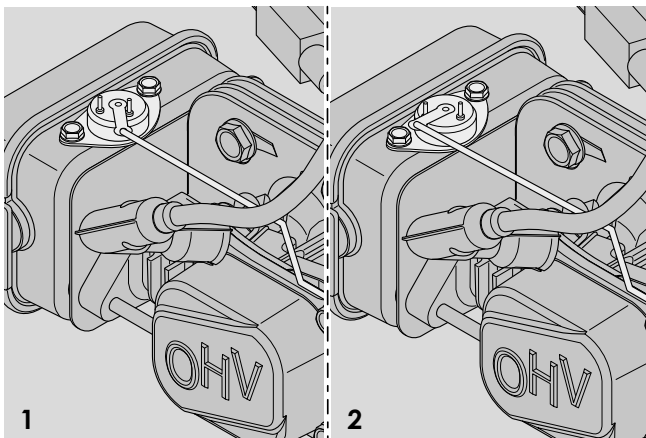
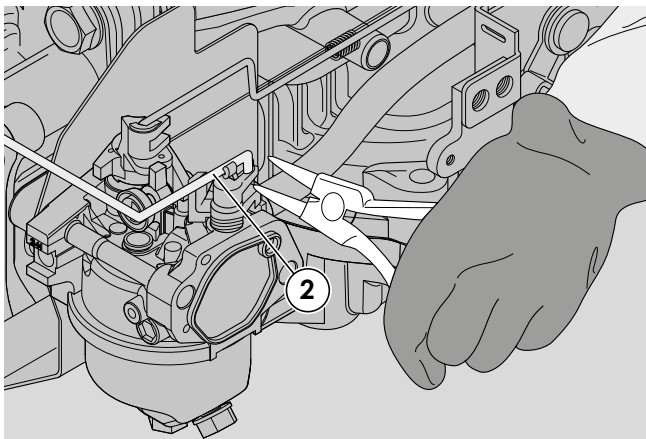
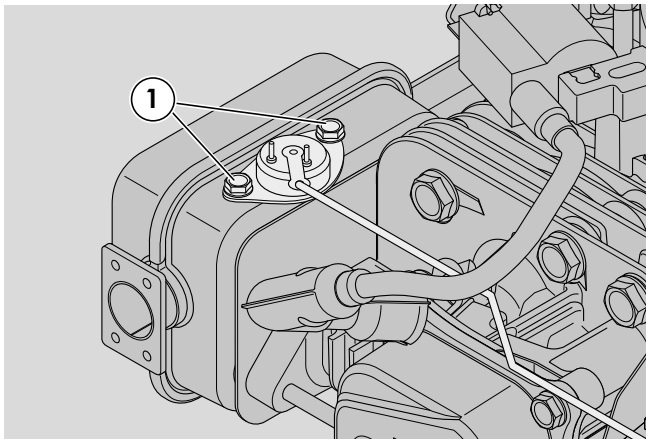

10.1. Replacing of the AUTO-CHOKE system

1 - Remove the cover.

2 - Remove the filtering unit.

3 - Unfasten the two screws (1).

4 - Using pliers pull the lever (2) connecting the AUTO-CHOKE system to the carburettor.

5 - Perform the above operations in reverse order when assembling.



NOTE:

1 - Cold engine: Closed throttle valve.

2 - Hot engine: Open throttle valve.

Tightening torques

1	Fixing screw AUTO-CHOKE	5-7 Nm
---	-------------------------	--------

11. IGNITION

General information

The **ignition system** has a flywheel with an electronic coil which supplies high voltage to the spark plug.

See the relevant section [\[🔧 16\]](#) for advice on resolving problems related to the ignition.

The coil and magneto flywheel are accessible by removing the cover.



NOTE: For engine removal operations you should consult the manual specific to the machine on which the engine itself is mounted.

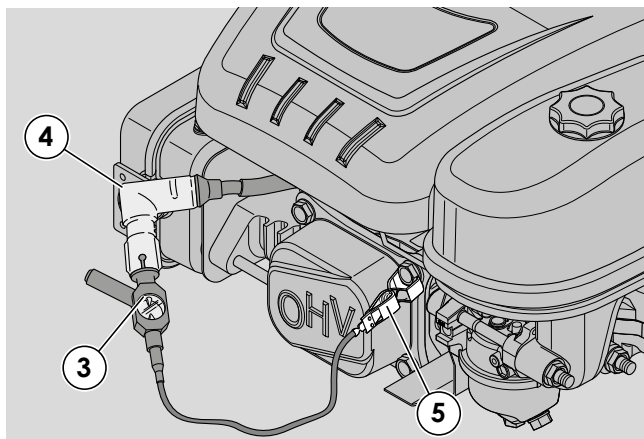
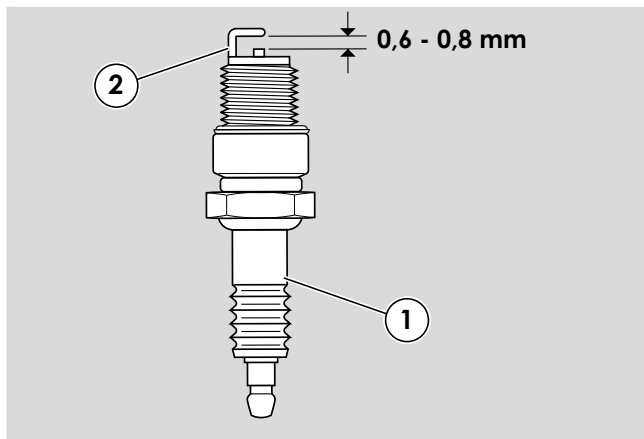

11.1. Checking the efficiency of the ignition system

1 - Dismount the spark plug (1) and look at the colour on the end of the thread. This can give you a good idea of the carburation:

- **black:** mixture too greasy due to clogged air filter;
- **nut brown:** regular carburation.

Replace the spark plug (with one of the same or equivalent characteristics) **if the electrodes (2) are burnt or if the porcelain is broken or cracked.**



FIRE HAZARD:

- **do not check the ignition system if the spark plug is not screwed in place;**

-  **always use the specific tool for the spark test.**

2 -  Connect the tester (3) to the spark plug cap (4) and to earth on the engine (5). Activate the starter and see in the instrument if the spark jumps.

3 - If the test has a positive result, clean the electrodes (2) with compressed air and adjust the distance to 0.6-0.8 mm. Remount the spark plug and tighten it to the specified levels.

Unless otherwise required, proceed to verify system components as indicated in section [\[🔧 11.2\]](#).

11. IGNITION

11.2. Adjusting the air gap and checking the coil

1 - Remove the starter assembly  6.1).

2 - Make sure that the earth cable faston (6) of the coil (7) is not oxidized; if it is, disconnect, clean and remount it, spraying it with a special antioxidant.

3 - Check that the coil earth cable is intact. The black spark plug cable (8) should not have any cracks or signs of deterioration or burns which reduce its efficiency and insulation level.

4 - Slack off the screw (9) and the stud (10) which secure the coil (7). Rotate the flywheel (11) so as to bring the magnetic inserts next to the poles of the core of the coil.

5 - Insert a 0.35 mm thickness gauge (12) between the flywheel (11) and the coil poles (7), push the coil until the poles come in contact with the thickness gauge and secure screw (9) and stud (10); with the flywheel locked, the airgap must be between 0,35 and 0,45 mm.



NOTE: An accurate inspection of the efficiency of a coil can only be carried out in a laboratory equipped with a oscilloscope.

To make a brief check, proceed as follows:

6 - Disconnect the earth cable faston (6) of the coi (7).

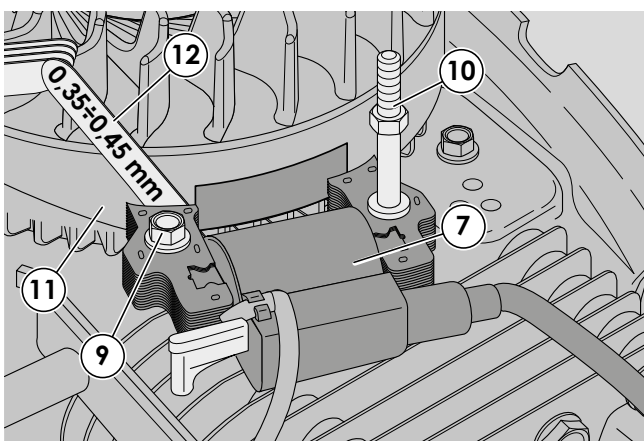
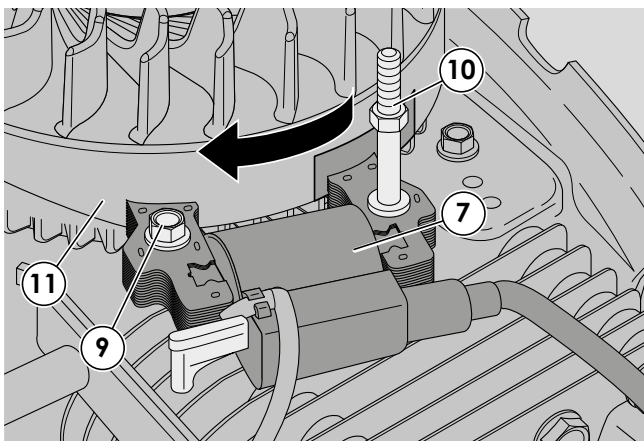
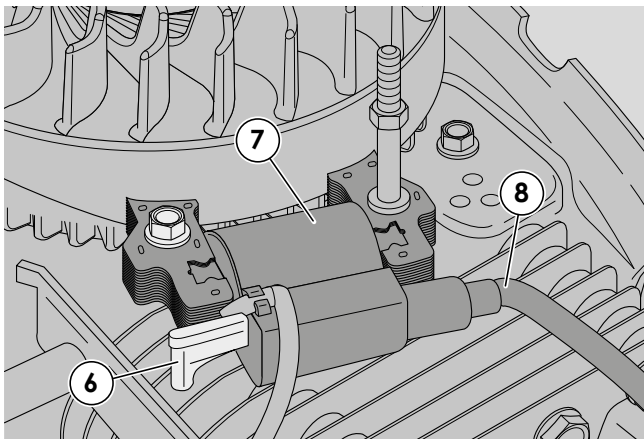

11. IGNITION

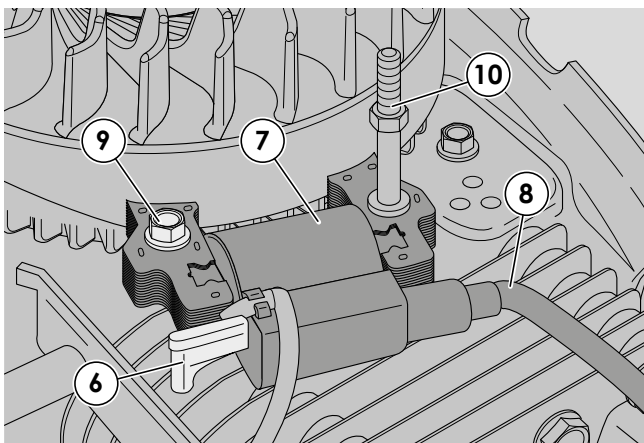
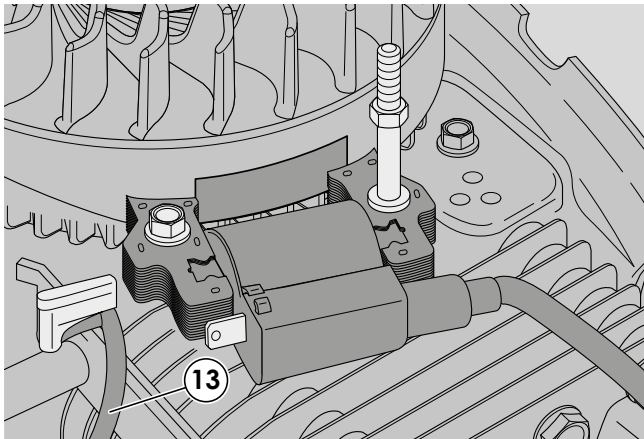

7 - Perform a spark test as indicated in [\[\[🔧 11.1\]\]](#).

- **If the spark jumps:** the coil functions properly and in the event of malfunction, verify that the cut-off cable (13) is not earthed.

- **if the spark does not jump:** the coil is faulty and must be replaced [\[\[🔧 11.2\]\]](#).

8 - Refit the starter assembly [\[\[🔧 6.1\]\]](#).

11.3. Replacing the coil

1 - Remove the starter assembly [\[\[🔧 6.1\]\]](#).

2 - Disconnect the faston of the earth cable (6).

3 - Undo the screw (9) and the stud (10) and remove the coil (7).

4 - Mount the new coil and regulate the air gap according to the procedure indicated in points 4 and 5 in section [\[\[🔧 11.2\]\]](#).

5 - Connect the faston of the earth cable (6).

6 - Refit the starter assembly [\[\[🔧 6.1\]\]](#).

Tightening torques

1	Spark plug tightening torque	27-30 Nm
9	Coil fixing screw	8-12 Nm
10	Coil fixing stud	8-12 Nm

Tightening torques

Type of spark plug	K7RTC or equivalent
Distance between electrodes	0,6-0,8 mm
Air gap/flywheel	0,35-0,45 mm

Special equipment

3 Tester for spark test

12. TURNING OFF AND STOPPING THE ENGINE

For maintenance operations relating to this section, refer to the manual specific to the machine on which the engine is mounted.

13. EXHAUST SYSTEM

General information

The **exhaust system** consists of a muffler installed on the cylinder together with a gasket, a spacer and a heatproof baffle.

See the relevant section [ 16] for advice on resolving problems related to the exhaust system.

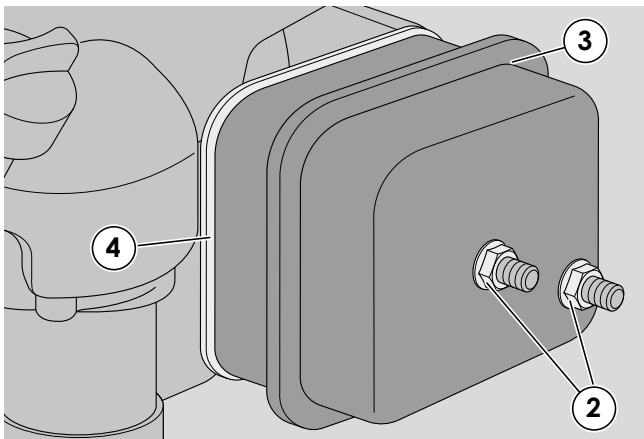
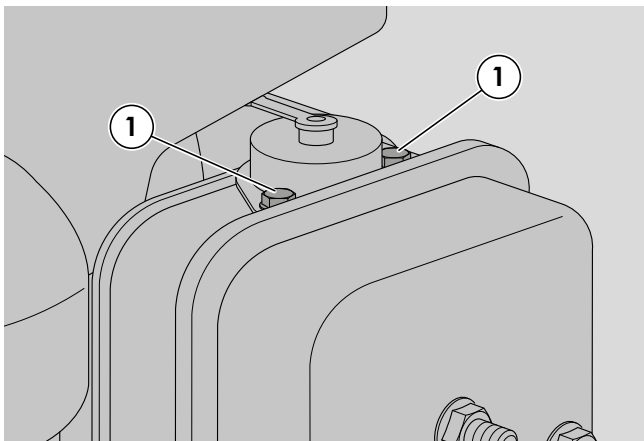

13.1. Removing and replacing the muffler

1 - Unscrew the two screws (1) securing the AUTO-CHOKE to the silencer, separating it from the exhaust unit.

2 - Remove the two nuts (2) that fix the muffler (3).

3 - Take out the muffler (3) and the heatproof baffle (4).

4 - On assembly:

- thoroughly clean the cylinder contact surface, removing all deposits or fragments on the heatproof baffle;
- always replace damaged mufflers;
- always replace the heatproof baffle (4) if it is broken or cracked;
- tighten the two nuts (2) to the specified levels.

Tightening torques

1	Fixing screw AUTO-CHOKE	5-7 Nm
2	Muffler nuts	8-12 Nm

14. ENGINE BLOCK - External operations

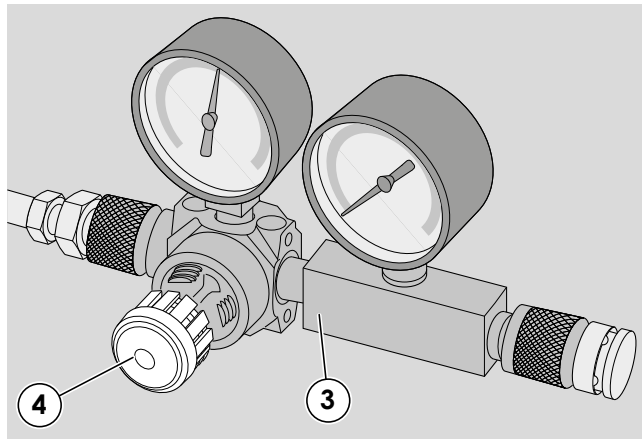
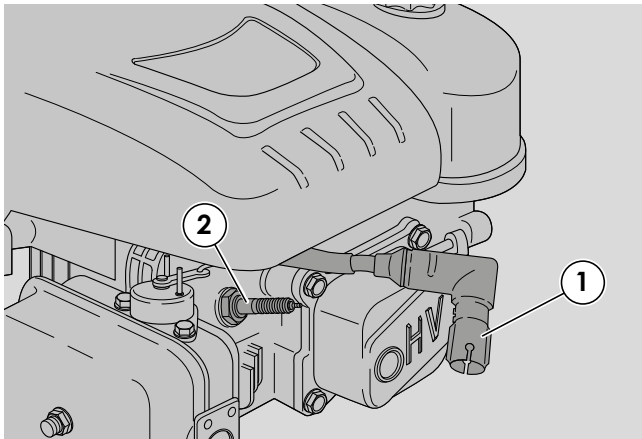

14.1. Checking the compression





1 - Remove the cap (1) and take out the spark plug (2).

2 - Manually set the piston to the TDC (Top Dead Centre) of the compression stroke so that both valves are closed.

3 -  Screw the terminal of the compression testing tool (3) into the spark plug hole and connect the supply pipe to a compressed air socket with a pressure of approximately 4 bar (58 psi).

4 - On opening the air tap (4), the manometer gauge on the engine side should position itself in the green zone and remain there for about 30 seconds. If the gauge falls rapidly it means that the compression is poor.

 **NOTE: Lack of compression could be due to:**

- incorrect valve clearance [ 14.2];
- cylinder head loose or cylinder head gasket worn [ 14.3].
- lack of seal in the valves [ 14.4];
- piston rings worn [ 14.3].

5 - Refit the spark plug (2) and close it to the indicated couple.

14. ENGINE BLOCK - External operations

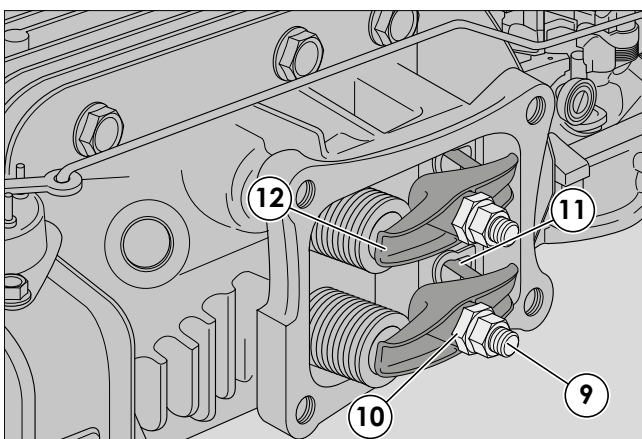
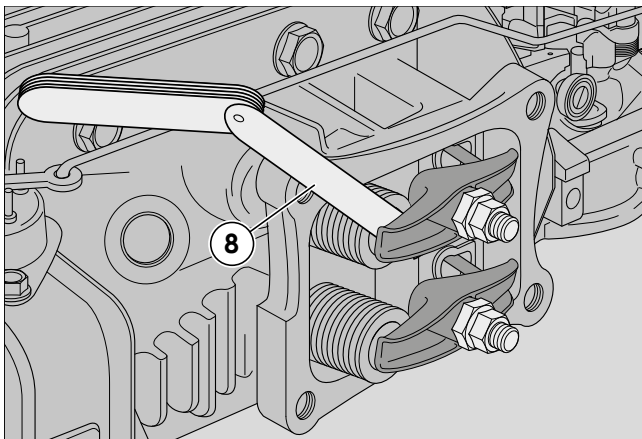
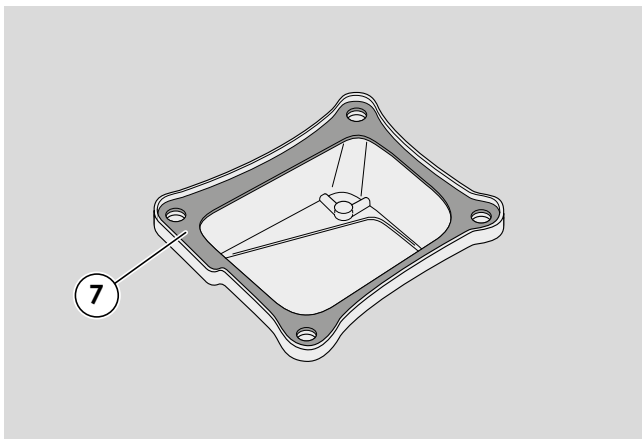
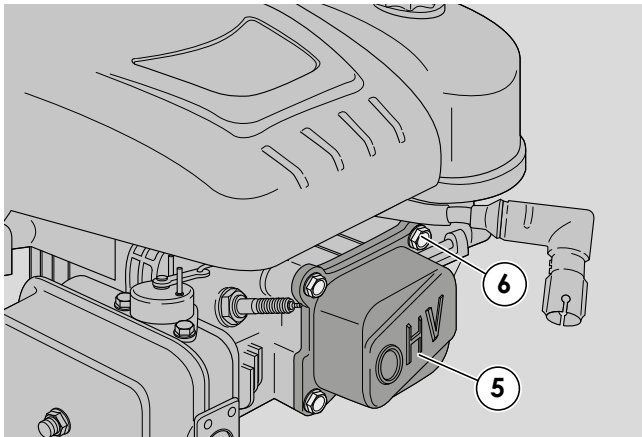

For some of the following operations the removal of the engine from the machine is required.



NOTE: For engine removal operations you should consult the manual specific to the machine on which the engine itself is mounted.

14.2. Adjusting the valve clearance



WARNING: The adjustment must be made with the engine is cold.

1 - Remove the cover and demount the spark plug.

2 - Remove lid (5) which is secured with four screws (6) and remove the washer (7).

3 - Manually set the piston to the TDC (Top Dead Centre) of the compression stroke so that both valves are closed.

4 - Use a feeler gauge (8) to check the gap between the rocker arm and the tip of the valve stem; the gauge should pass between without forcing and without a further gap.

5 - The gap is adjusted by slackening off the nut (9) and suitably adjusting the register nut (10) to obtain the following values:

Inlet - IN (YI) = 0,10 - 0,15

Exhaust - EX (YE) = 0,15 - 0,20

6 - Following adjustment, check that the pushrods (11) are properly inserted in the rocker arm housings (12) and always fully tighten the nut (9).

7 -  When reassembling check the condition of the gasket (7) of the cover (5) and replace it if it is damaged. Tighten the screws (6) to the torque indicated.

8 - Assemble the spark plug.

14. ENGINE BLOCK - External operations

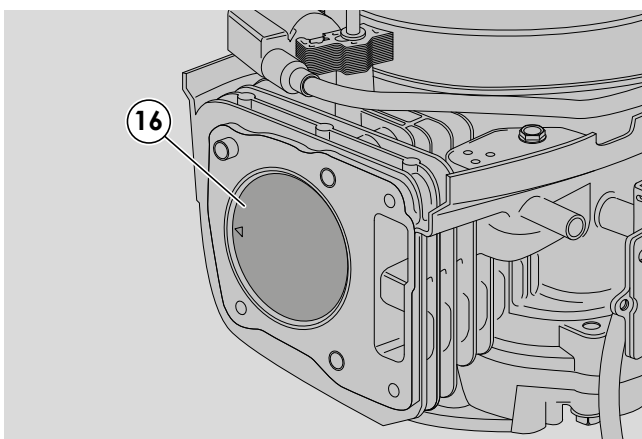
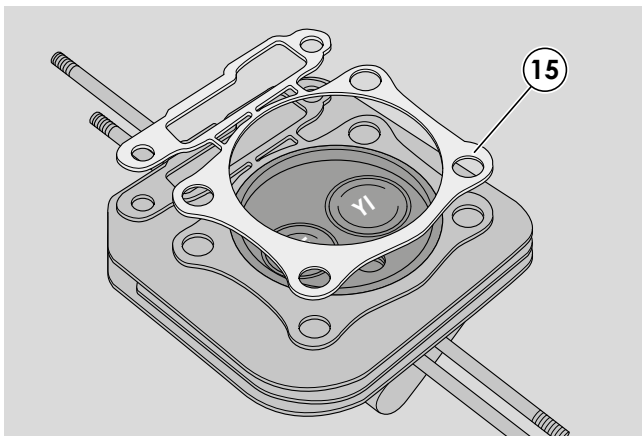
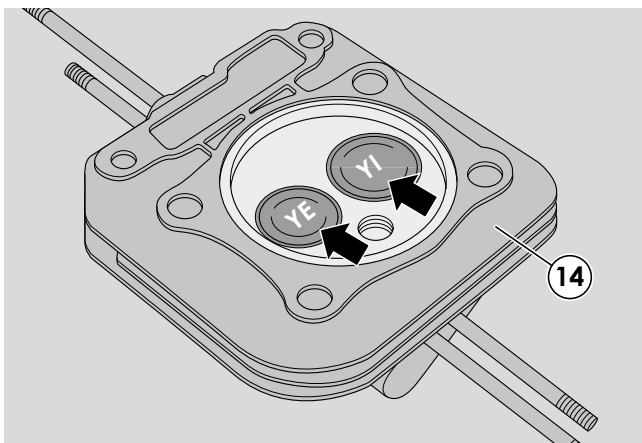
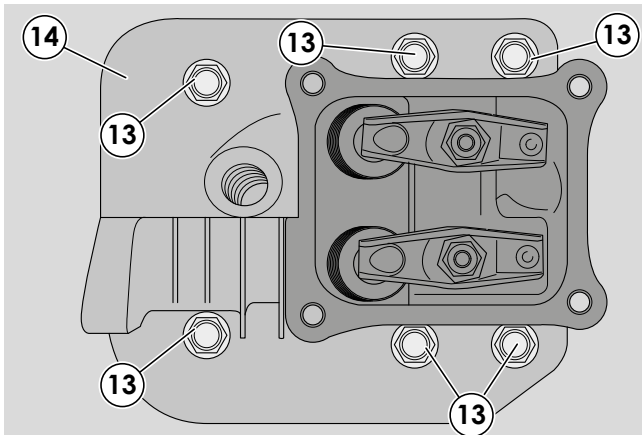

14.3. Dismantling and cleaning the cylinder head

1 - Remove the cover and demount the spark plug.

2 - Remove the cover.

3 - Remove the carburettor  8.1).

4 - Remove the exhaust muffler  13.1).

5 - Unscrew the six screws (13) and remove the cylinder head (14).

6 - Remove the gasket (15).

7 - Clean the cylinder head (14) and cylinder surfaces (16).

8 - Carefully clean the inside of the combustion chamber and remove possible deposits from the valve seats.

9 - Turn the flywheel by hand to move the piston and check the internal surface of the cylinder (16).

10 - When mounting:

- the gasket (15) must always be replaced;
- Remount the cylinder head (14) screwing the six screws (13) without fully tightening, then tighten them to the given torque values, using a cross-over sequence.

Take care that the pushrods are positioned correctly in their housings.

11 - Remount the items removed in the reverse order used in dismantling.

14. ENGINE BLOCK - External operations

14.4 Overhauling the cylinder head and valves

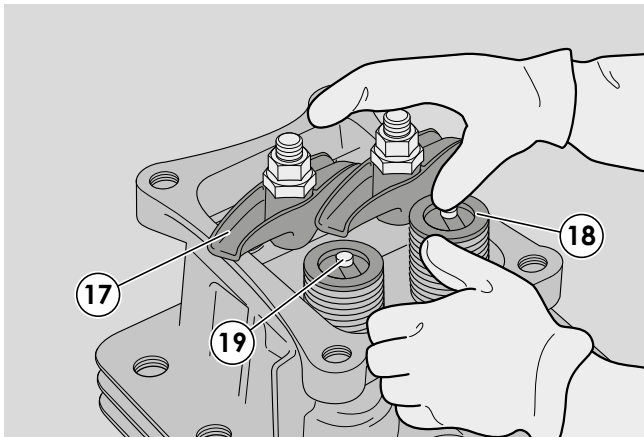

NOTE: These paragraphs describe all the operations for checking and overhauling the cylinder head;

it is left to the operator to assess the advisability of performing all the operations described or only part of them, depending on the type of engine problems encountered.

1 - Dismount the cylinder head [👉 14.3].

2 - Move the rocker arms (17); press down the spring seal cap (18) and move it sideways to remove from the valve stem (19).

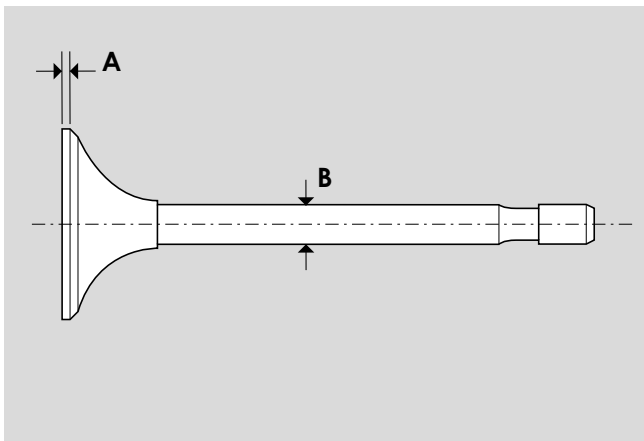

IMPORTANT - The inlet and exhaust valves are different from each other and can be identified by the marking «IN» (YI - inlet) and «EX» (YE - exhaust), on the valve head.

3 - Use an emery cloth to remove all incrustations from the valve head and check the thickness of the rim (A); the valve must be replaced if the margin (A) is less than 0,5 mm (inlet - IN/YI) or 0,5 mm (exhaust - EX/YE) or if it shows signs of burning.

4 - Check the diameter of stem (B) in several points and replace the valve if it is less than the following, even if only in one point:

5,32 mm (inlet - IN/YI)

5,27 mm (exhaust - EX/YE)



NOTE: The valve seats must be ground by hand, using a special grinding tool with an angle of 45°.

5 -  Insert the pin (20) in the cylinder head valve guide and then the grinding tool (21).

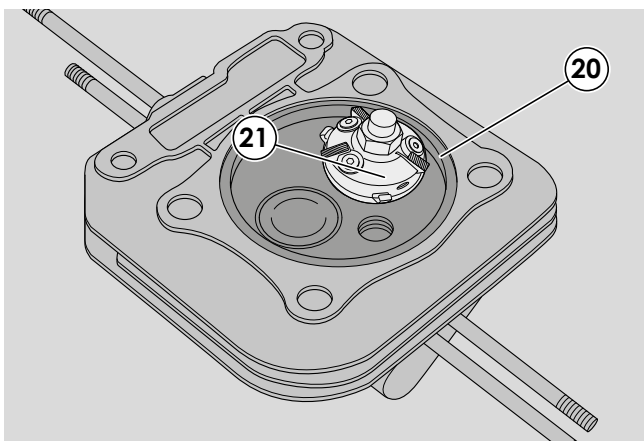

NOTE: Grinding must be done taking care to remove as little material as possible.

6 - Use a caliper gauge to check the depth of the valve seat (C), which must be 2,0 mm; the cylinder head must be replaced if a greater value is measured.

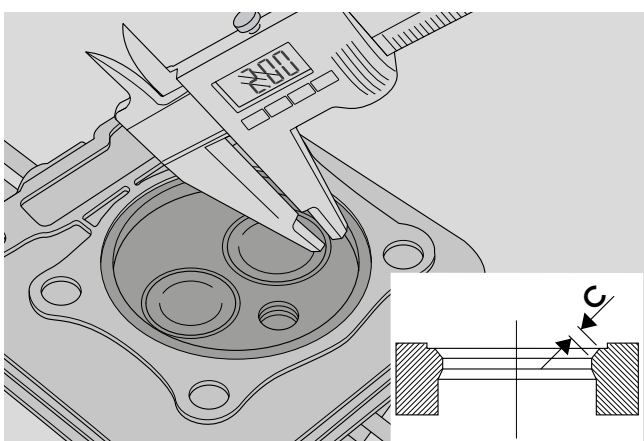

14. ENGINE BLOCK - External operations

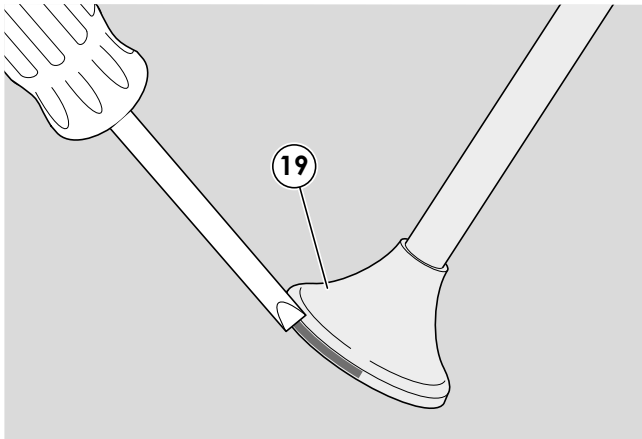

7 - Apply abrasive paste for grinding around the rim of the valve head (19) and then insert the valve into its seat.

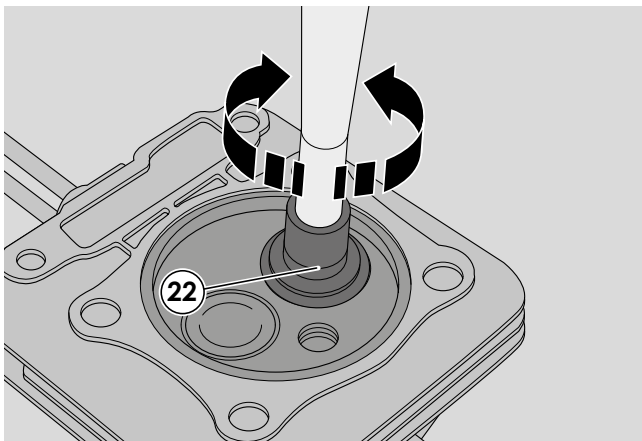

8 -  Use the special manually operated tool (22) to grind the seat and rim of the valve.

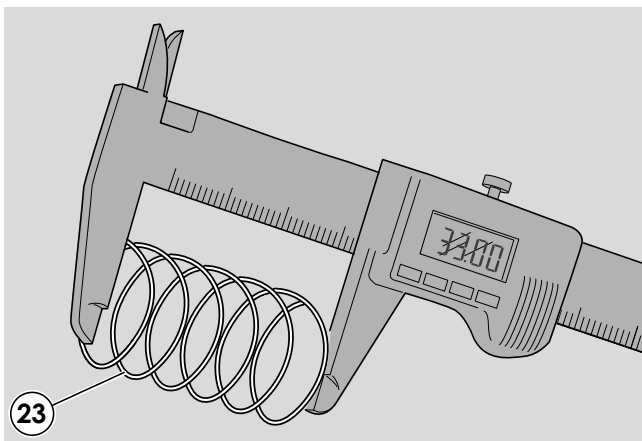

9 - Remove the valve and use clean petrol to carefully clean all traces of paste or metal residues from the valve seat and rim.

10 - Check the free length of the spring (23) and replace the spring if it is less than 33,0 mm.

11 - When mounting:

- carefully clean the valve guides and housings of any foreign body;

- apply a film of oil on the valve stems before inserting them in their respective housings;

- ensure the correct position of the inlet valve and the exhaust valve, marked, respectively, with «YI» and «YE» on the valve head.

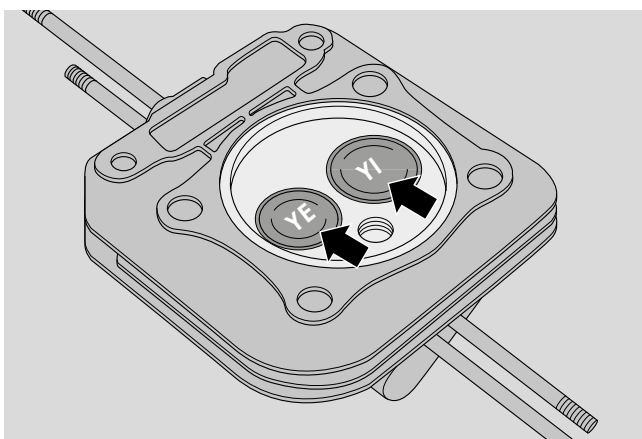

12 - Remount the cylinder head [ 14.3] and fix the screws to the indicated couple.

13 - The valve clearances must be checked whenever the cylinder head is removed and refitted [ 14.2].

14. ENGINE BLOCK - External operations

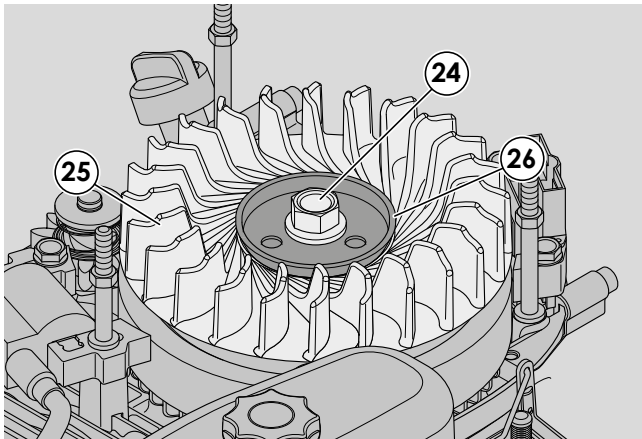

14.5. Dismantling and replacing the magneto flywheel

1 - Remove the starter unit to facilitate the operation [\[\[🔧 6.1\]\]](#).

2 - Using a pneumatic screwdriver, unscrew the nut (24) and remove the fan (25) retrieving the plate (26).

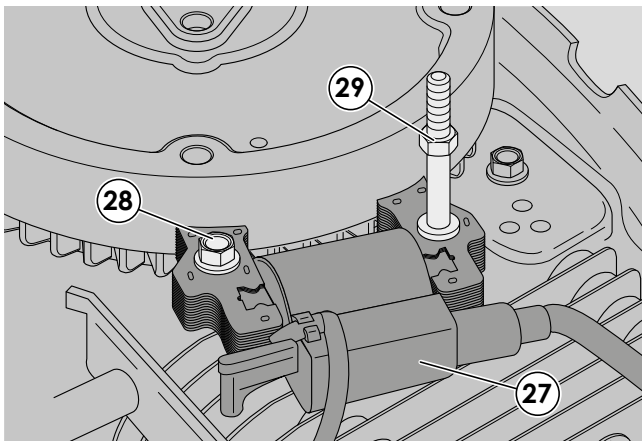

3 - Undo the screw (28) and the stud (29) and remove the electronic coil (27).

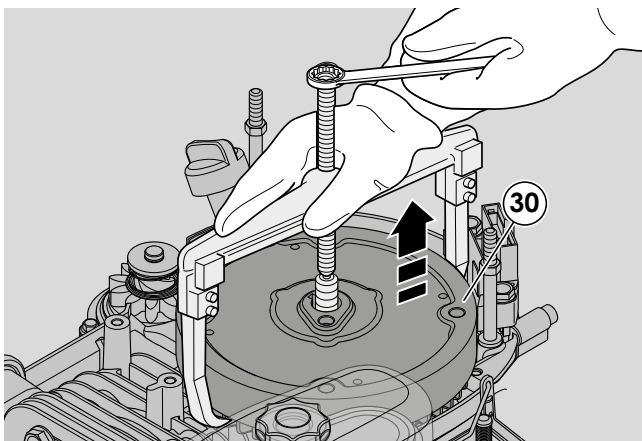

4 -  Using a suitable extraction tool, remove the flywheel (30) as indicated in the diagram. **Ensure that the engine shaft key is retained.**

5 - While assembling the fly-wheel check the integrity of the key (31) and replace it if it is deformed; mount the plate (26) and the fan (25). Tighten the nut to the specified torque (24).

6 - Refit the coil (27), tightening the screw (28) and the stud (29) to the torque indicated.

7 - Readjust the airgap until it is correct [\[\[🔧 11.2\]\]](#).

8 - Refit the starter assembly [\[\[🔧 6.1\]\]](#).

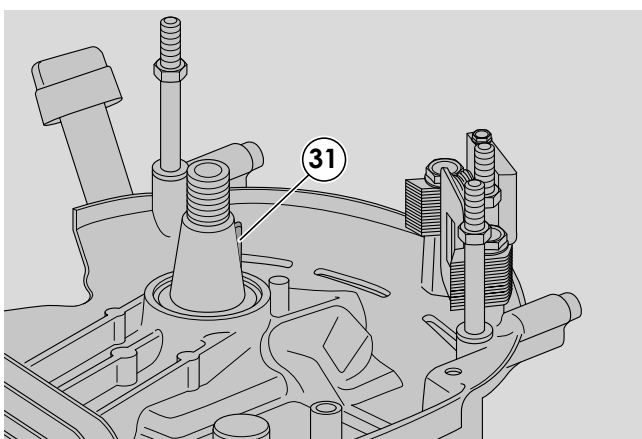

14. ENGINE BLOCK - External operations

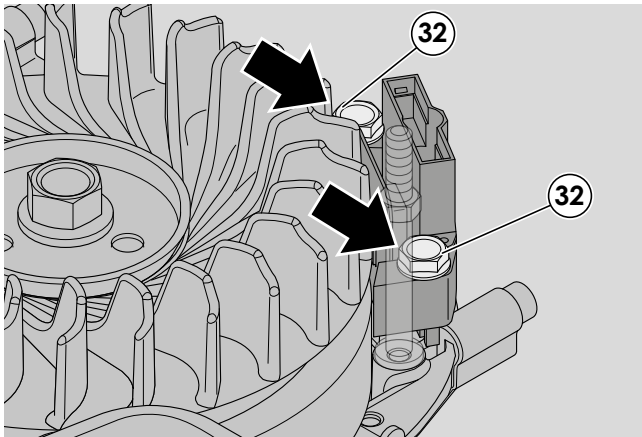

14.6. Alternator removal and replacement

1 - Remove the two screws (32) and disconnect the connectors from the live cable.
In case of malfunction replace the alternator.

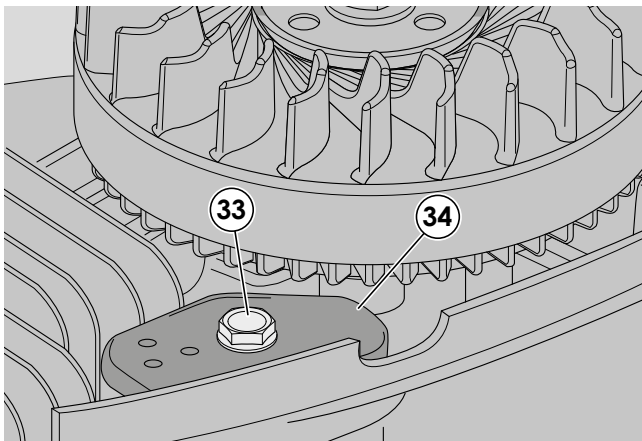

14.7. Checking the oil breather

1 - Unscrew the screw (33) fixing the closing plate (34).

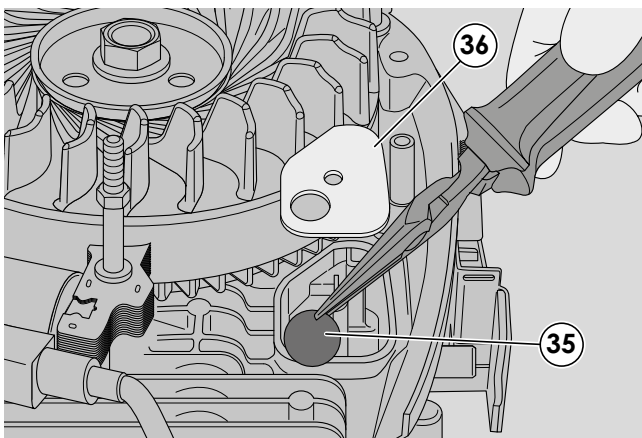

2 - Check that the pad (35) is not damaged or deformed. Replace it if necessary.
If necessary wash with water and neutral detergents.

3 -  If necessary, replace the cork gasket (36) and reassemble the closing plate (34), tightening the screw with the indicated torque.

14. ENGINE BLOCK - External operations

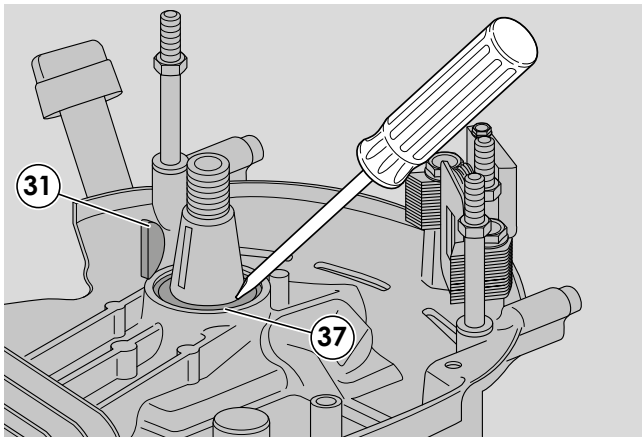

14.8. Replacing the upper compression ring of the engine shaft (flywheel side)

1 - Remove the magneto flywheel [🔧 14.5].

2 - Take out the spline key (31).

3 - Use a thin screwdriver inserted under the sealing lip to extract the oil seal ring (37).

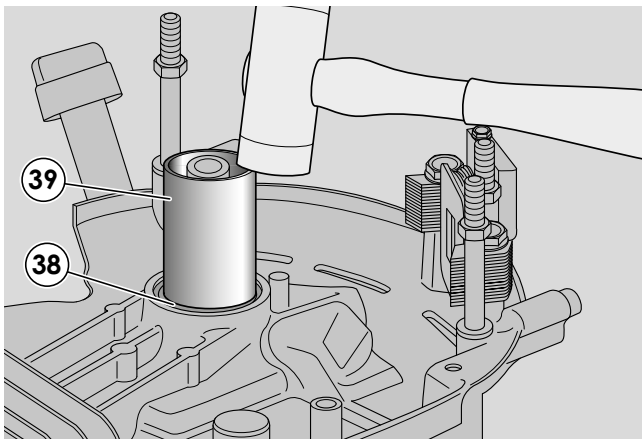

4 - The new ring (38) must be inserted with the help of a pipe (39) with a diameter of approximately 30-35 mm, taking care not to damage the sealing lip.

5 - Refit the key (31) and the magneto flywheel [🔧 14.5].

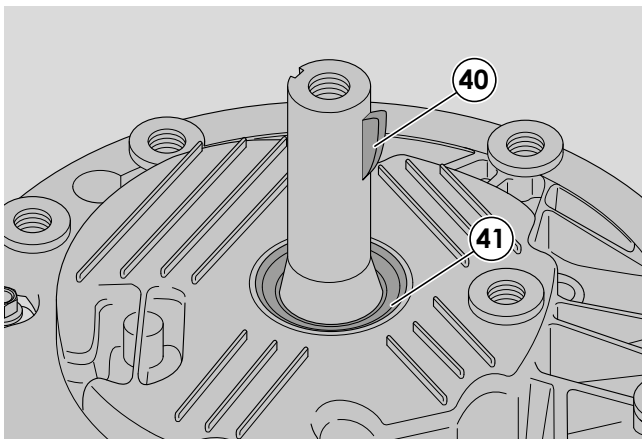

14.9. Replacing the lower compression ring of the engine shaft (sump side)

☑ **NOTE:** For engine removal operations you should consult the manual specific to the machine on which the engine itself is mounted.

☑ **NOTE:** Before executing this operation discharge all the oil from the bowl and rotate 180° the motor.

1 - Take out the spline key (40).

2 - Use a thin screwdriver inserted under the sealing lip to extract the oil seal ring (41).

3 - Make a paper tube (42) around the shaft to protect the sealing lip and insert the new ring (43) so that it enters its housing.

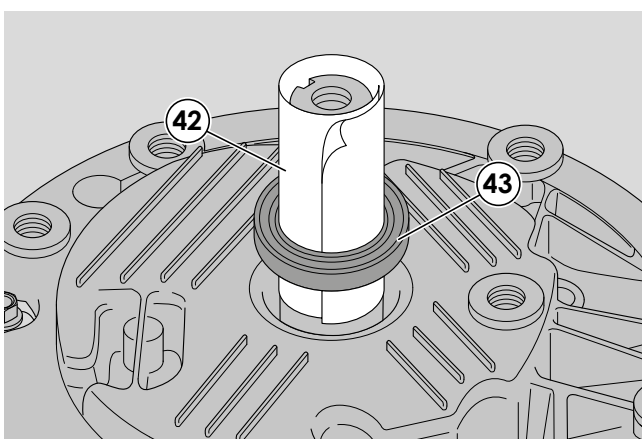

14. ENGINE BLOCK - External operations

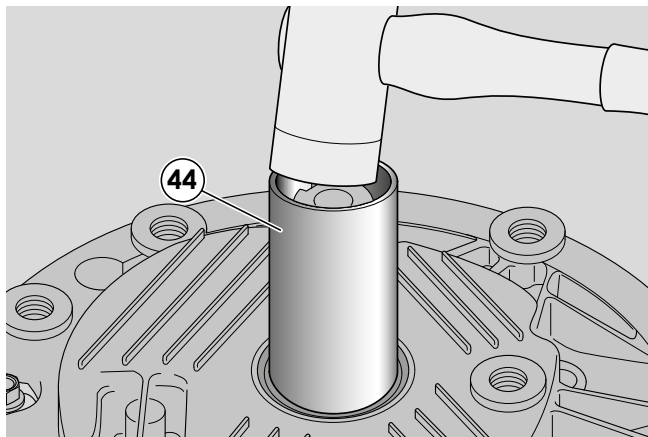

4 - Complete the insertion with the help of a pipe (44) of a diameter of approximately 30-35 mm.

Tightening torques

2	Spark plug tightening torque	27-30 Nm
6	Valve cover fixing screws	8-12 Nm
13	Cylinder head screws	30-36 Nm
24	Flywheel fixing nut	80-90 Nm
28	Coil fixing screw	8-12 Nm
29	Coil fixing stud	8-12 Nm
32	Fixing screws generator	8-12Nm
33	Pad plate screw	4-6 Nm

Technical information

Compression	Min. 4 bar
Inlet valve clearance	0,10-0,15 mm
Exhaust valve clearance	0,15-0,20 mm
Minimum inlet valve stem diameter	5,32 mm
Minimum exhaust valve stem diameter	5,27 mm
Min. inlet valve head rim thickness	0,5 mm
Min. exhaust valve head rim thickness	0,5 mm
Valve seat depth	2,0 mm
Minimum valve spring length	33,0 mm

Special equipment

- 3** Compression testing tool
- 21** Valve seat grinding tool
- 22** Valve grinder

15. ENGINE BLOCK - Overhauling internal parts

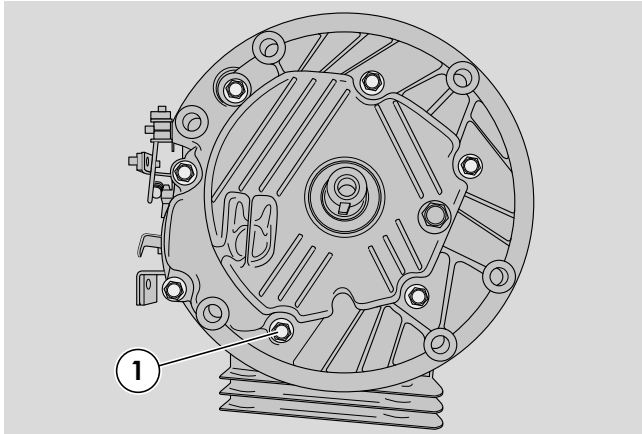

All the following operations on the grass cutter necessitate the removal of the motor.



NOTE: For engine removal operations you should consult the manual specific to the machine on which the engine itself is mounted.

15.1. Carter opening

1 - Position the engine on a stable support and remove the sparkplug.
Bring the piston to the TDC (Top Dead Centre).

2 - Turn the engine up-side-down and position it so that the shaft projects upwards.

3 - Open the crankcase sump by unscrewing the seven screws (1).

4 - verify the phasing between the engine shaft and the camshaft;

If necessary, re-set the phasing, referring to the indications provided.

5 - On assembly, follow the steps described in reverse and:

- always replace the gasket (2) between cover and sump;
- ensure that the two centring pins (3) are correctly inserted;
- always replace the compression ring from the sump side [[🔧 14.8].
- ensure that the governor lever (4) is facing upwards;
- close the screws (1) intersection lock bowl to the indicated couple;

6 - After installing the engine on the machine:
- refill the sump and make sure that the filler plug is tight.
- check the adjustment of the throttle cable [[🔧 9.1].

7 - Following reassembly it is advisable to check the engine's peak rpm [[🔧 9.2].

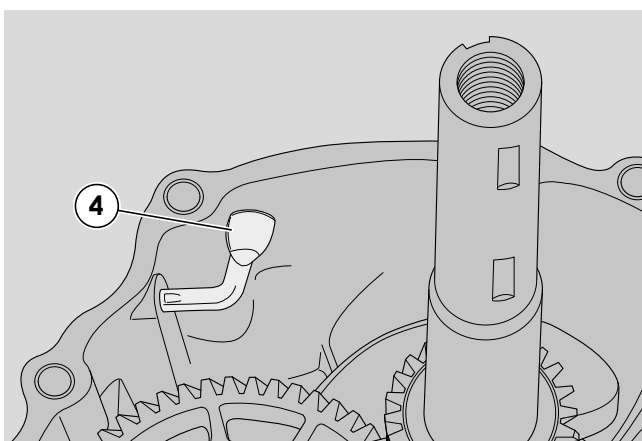
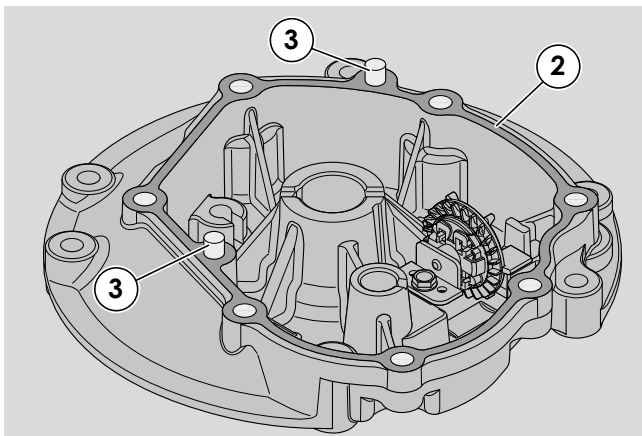
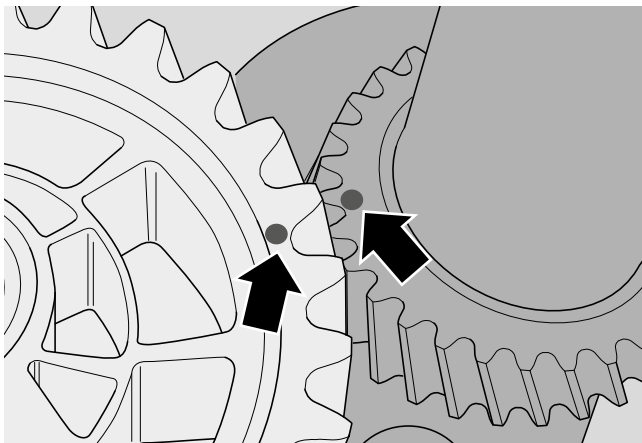

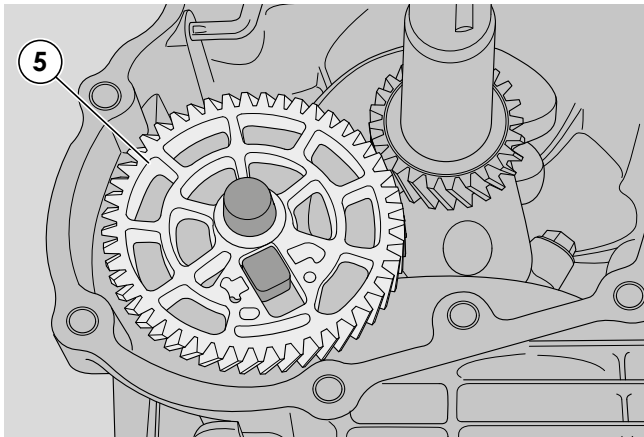

15. ENGINE BLOCK - Overhauling internal parts



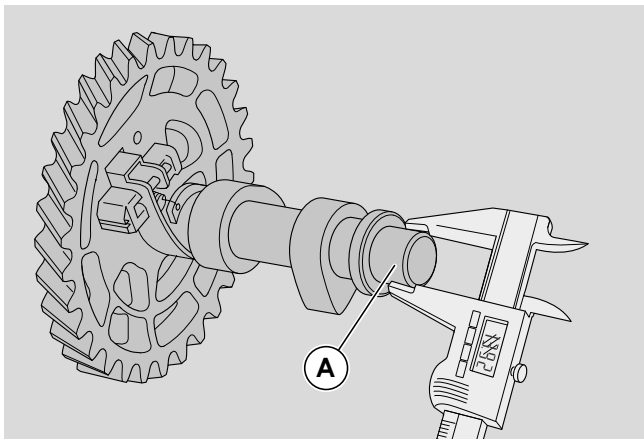

15.2. Dismantling and checking the camshaft and counterweight governor

- 1 - Bring the piston to the TDC (Top Dead Centre).
- 2 - Open the crank case  15.1).
- 3 - Remove the camshaft (5).

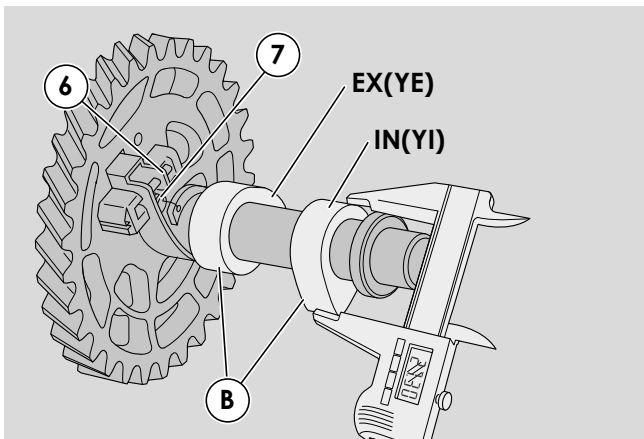

- 4 -  Measure seat (A) of the camshaft, checking for wear and tear. The value must not be lower than 13,92 mm.



- 5 -  Measure the cams (B), checking for wear and tear. The value must not be lower than 27,30 mm IN (YI) and 27,45 EX (YE).

- 6 - Check the regular movement of the pressure reducer (6) and the efficiency of the spring (7); the whole group must always be replaced in the case of breakage or irregular operation of the pressure reducer.

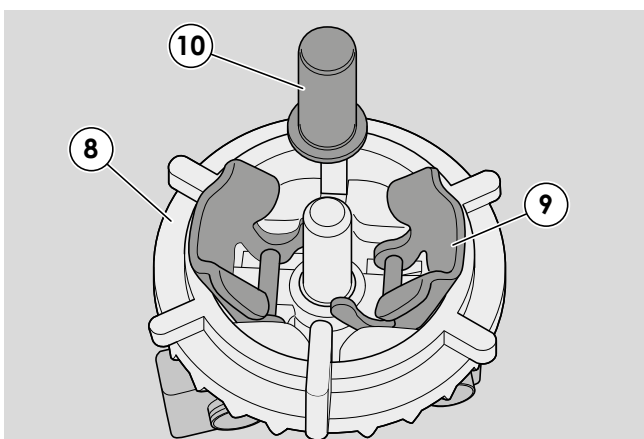

- 7 - Check that the irregular centrifugal (8) that are not present ruptures of the lubrication pallets.

- 8 - Turn the governor's gears quickly and check that the counterweights (9) expand correctly, causing the pin (10) to be moved axially.

15. ENGINE BLOCK - Overhauling internal parts

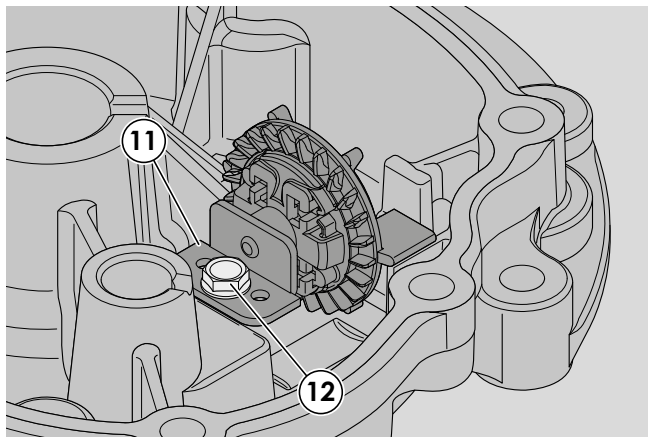

9 - In the case of breakage or irregular operation of the counterweights the whole group, fixed by a plate (11) and a screw (12) must be replaced.

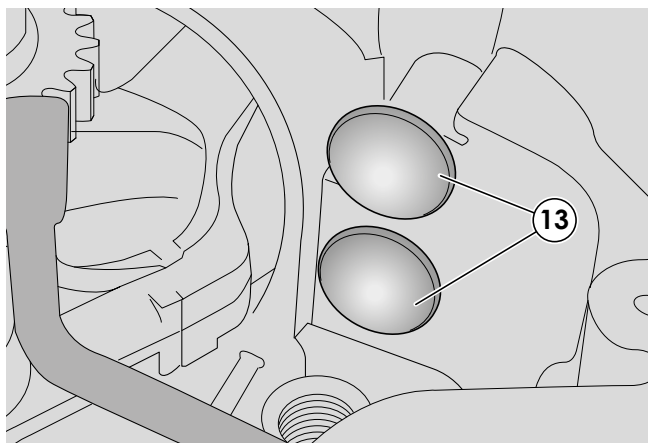

10 - Before fitting the camshaft ensure that the two tappets (13) are correctly housed in their seats.

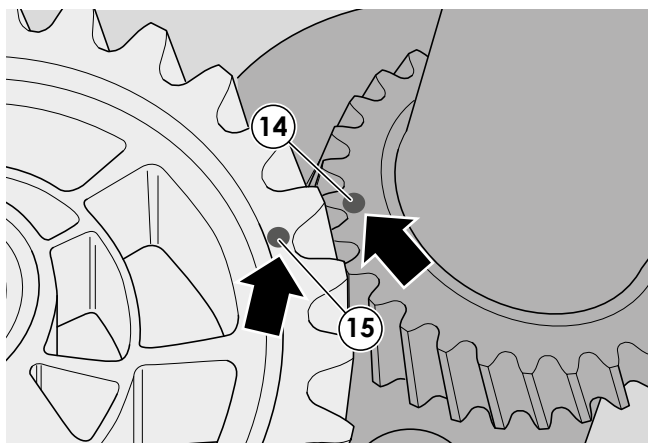

11 - When refitting the camshaft, maximum care must be taken to match up the two references (14) and (15) punched on the gears, so as to ensure correct distribution phasing.

12 -  During assembly, refer to the operations in section [15.1](#) always remembering to replace the washer (2) between the sump and the housing.

15. ENGINE BLOCK - Overhauling internal parts

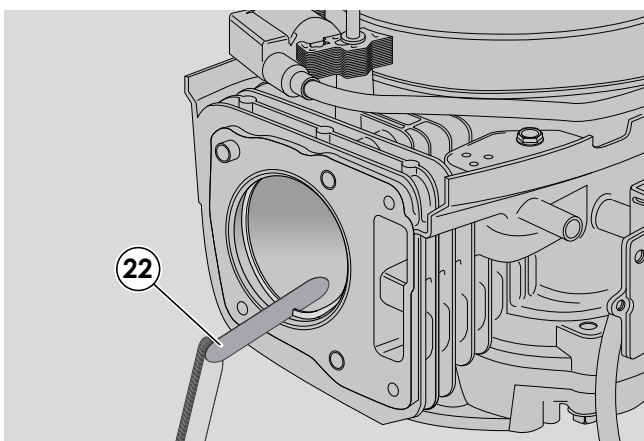
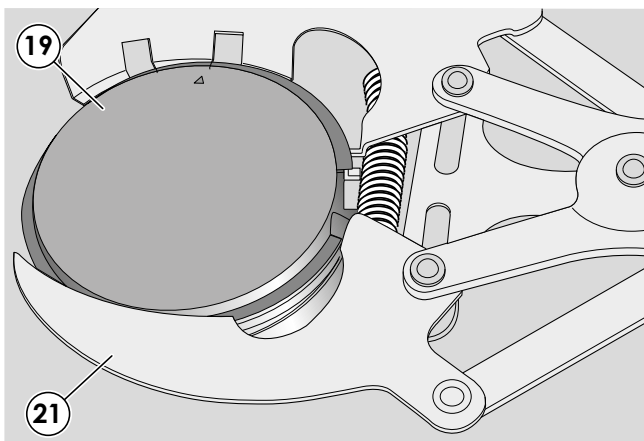
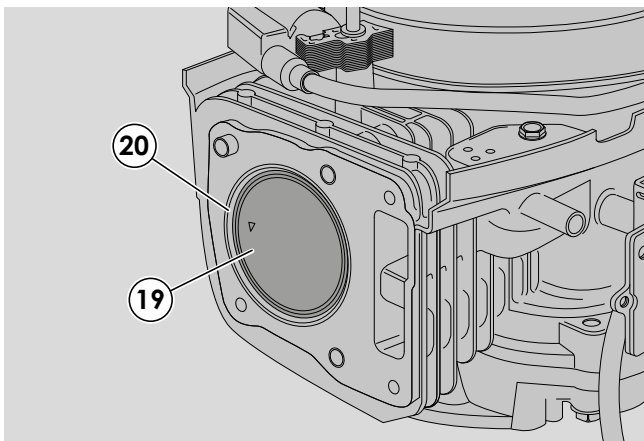
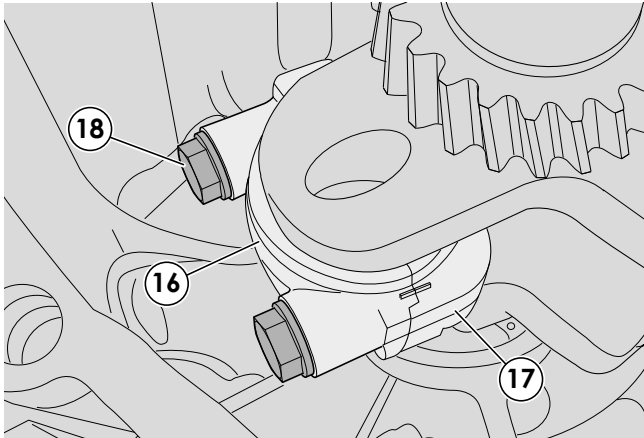

15.3. Dismantling and checking the piston, piston rings, connecting rod and engine shaft



NOTA: These paragraphs describe all the operations for checking and overhauling the thermal components of the engine; it is left to the operator to assess the advisability of performing all the operations described or only part of them, depending on the type of engine problems encountered.

All the following operations on the grass cutter necessitate the removal of the motor.



NOTE: For engine removal operations you should consult the manual specific to the machine on which the engine itself is mounted.

- 1 - Remove the magneto flywheel [👉 14.5].
- 2 - Open the cover [👉 15.1].
- 3 - Remove the camshaft [👉 15.2].
- 4 - Dismantle the cap (16) of connecting rod (17) fixed with two screws (18) (take note of any reference marks for refitting).
- 5 - Push the connecting rod (17) so as to cause the piston (19) to come out of the cylinder (20).
- 6 -  Use the special expanding tool (21) to remove the two compression rings and the oil scraper ring from the piston (19).
- 7 - Carefully remove all carbon deposits from the compression rings, the inside of the cylinder and the piston head.
- 8 - To check the wear in the compression rings, insert them one at a time into the cylinder (20) by about 10-15 mm and measure the gap between the two ends with a feeler gauge (22); the rings must be replaced if the gap is more than 1 mm.



NOTE: If a gap of more than 0.6 mm is measured with new rings it means that the cylinder is worn beyond the acceptable limits and must be replaced. The cylinder must be replaced if it shows striping due to a seizure.

15. ENGINE BLOCK - Overhauling internal parts

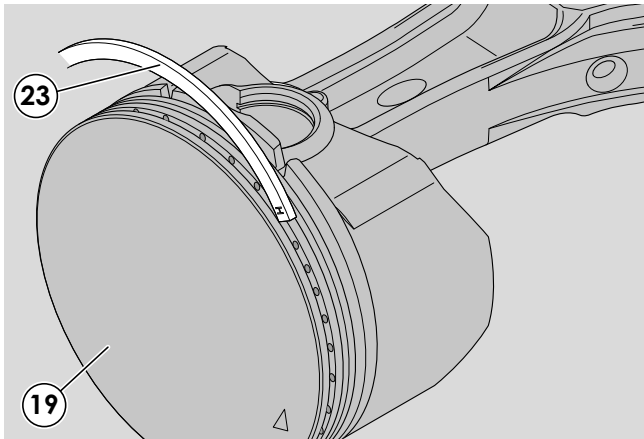

9 - Use a section of an old ring (**23**) to carefully clean the inside of the piston (**19**) ring housings, ensuring that the oil passage holes are not blocked.

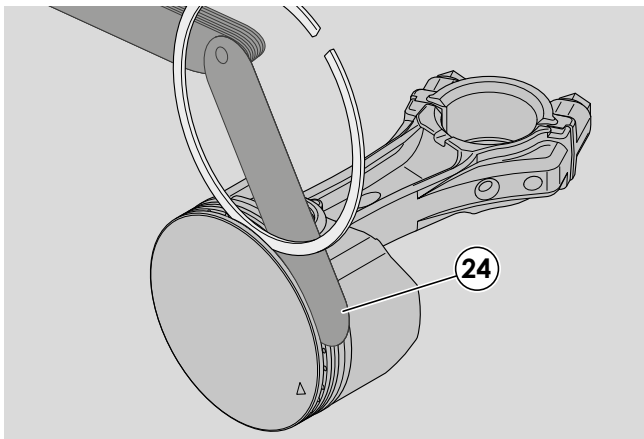

10 - To check the wear in the piston ring housings, fit a new ring and measure the residual space with a feeler gauge (**24**). The piston must be replaced if it is greater than 0.15 mm in the two compression ring housings.

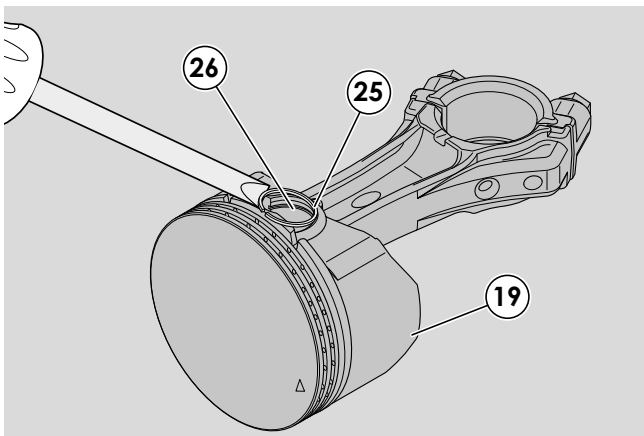

11 - Use a screwdriver to remove the clamping ring (**25**) and remove the gudgeon pin (**26**) from the piston (**19**).

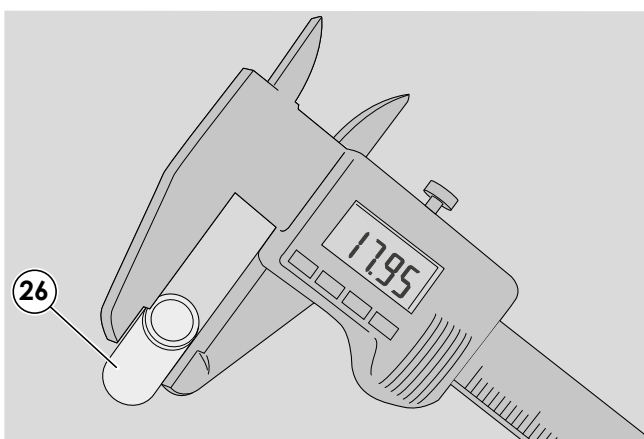

12 - Check the diameter of the gudgeon pin (**26**) in several places and replace it if it is less than 17,95 mm, even at a single point.

15. ENGINE BLOCK - Overhauling internal parts

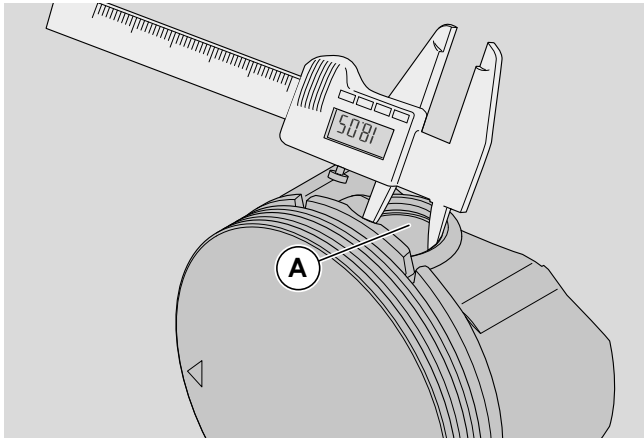

13 - Check the diameters of the gudgeon pin housings (**A**) on the piston (**19**) and replace the piston if they are more than 18,05 mm, even at a single point.

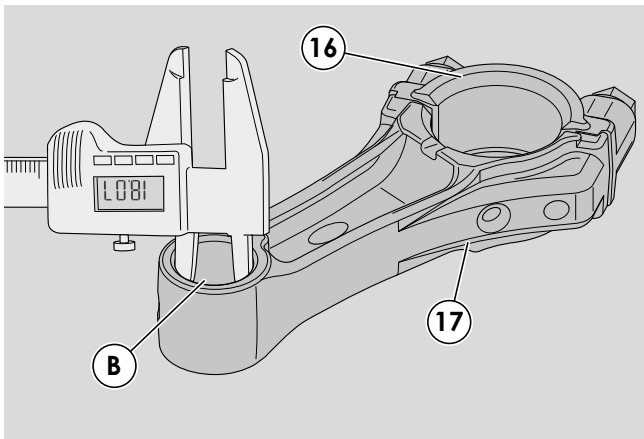

14 - Fit the cap (**16**) to the connecting rod (**17**) and check the diameter from the gudgeon pin side and the crank side; replace the connecting rod if the values are greater than:

B : 18,07 mm on the gudgeon pin side;
C : 30,07 mm on the crank side.

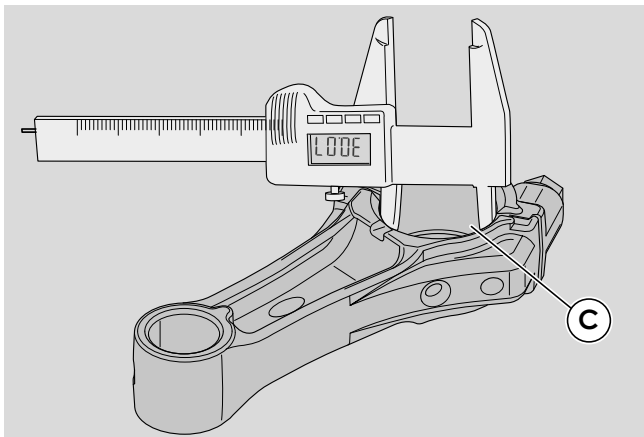

If the connecting rod is outside measurement tolerances or has small scratches or marks, it is necessary to replace it.

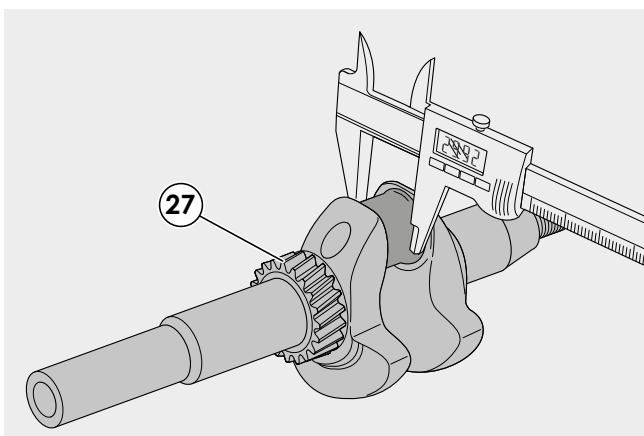

15 - Remove the engine shaft (**27**) checking the diameter of the connecting rod pin with a digital gauge.

The value must not be less than 29,92 mm or the engine shaft will have to be replaced.



NOTE: In the case of seizing, the manifolds can be polished with fine emery cloth, only removing foreign matter and checking that the final size remains within the aforementioned limit.

15. ENGINE BLOCK - Overhauling internal parts

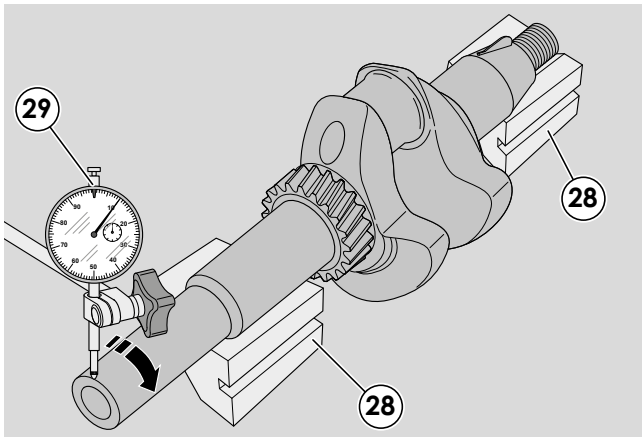

16 - To check the alignment between the manifolds and the protruding part of the shaft, place the engine shaft on two prismatic guides (28) and, with the help of a comparator (29) placed at the end, check the displacement by rotating the shaft. The shaft must be replaced if the displacement exceeds 0.10 mm.



IMPORTANT: A bent shaft must never be repaired!



WARNING - DANGER: A bent shaft causes abnormal vibrations and could be dangerous when the machine is used!

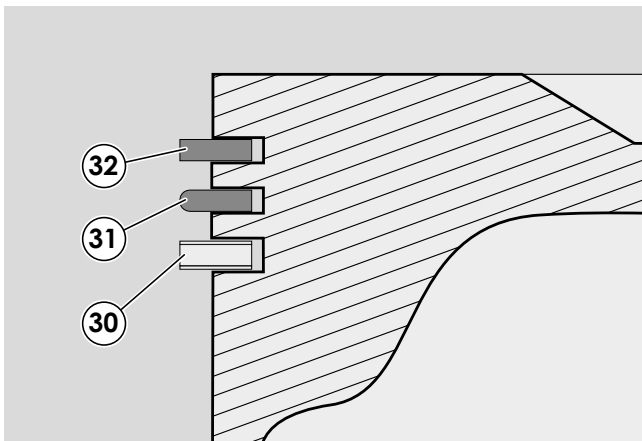

17 - To reassemble the segments on the piston perform sequentially:

- Mount the oil wiper (30), composed of three rings;
- Assemble the rounded edge segment (31) with the rounded edge facing downwards;
- Assemble the live edge segment (32).



NOTE: The two segments (31) and (32) must be oriented with the lights not aligned between them.

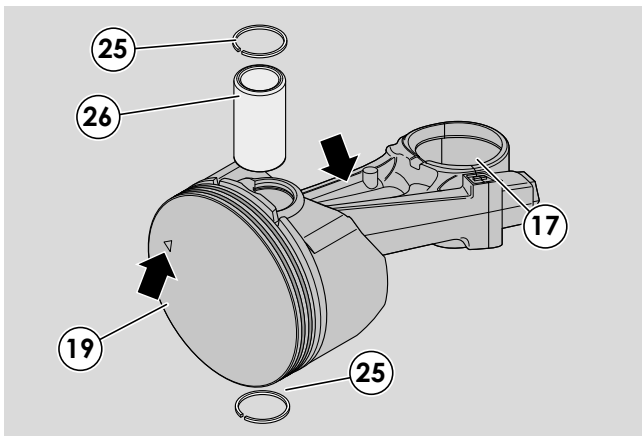

18 - Fit the connecting rod (17), the gudgeon pin (26) and clamping rings (25) to the piston (19), taking care over the connecting rod marking, which must be pointing towards the engine shaft exit. Piston marking must point towards the exhaust.

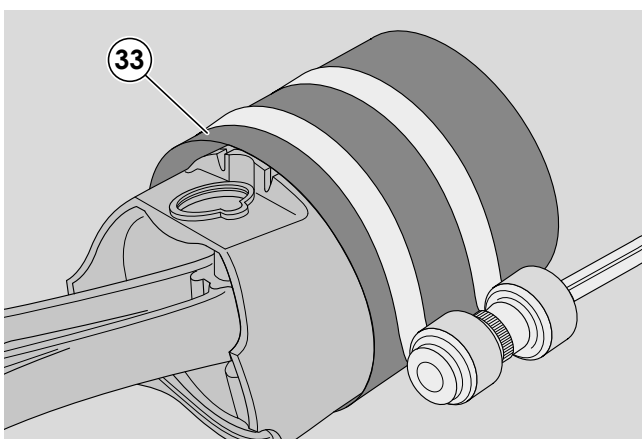

19 - Put the piston into the ring compression tool (33).

15. ENGINE BLOCK - Overhauling internal parts

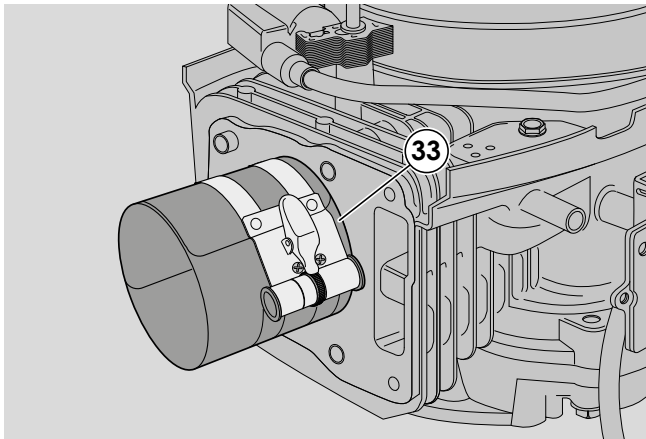

20 - Oil the inside of the piston liberally and insert the piston, with the marking facing the exhaust.

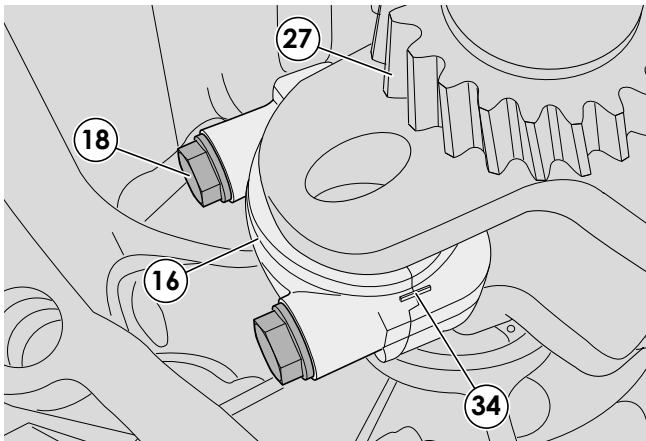

21 - Mount the engine shaft (27) and the connecting rod cap (16) with the relative screws (18), taking care with the position references (34) so as to avoid inverting the mounting direction of the cap.
Close the screws (18) to the indicated couple.

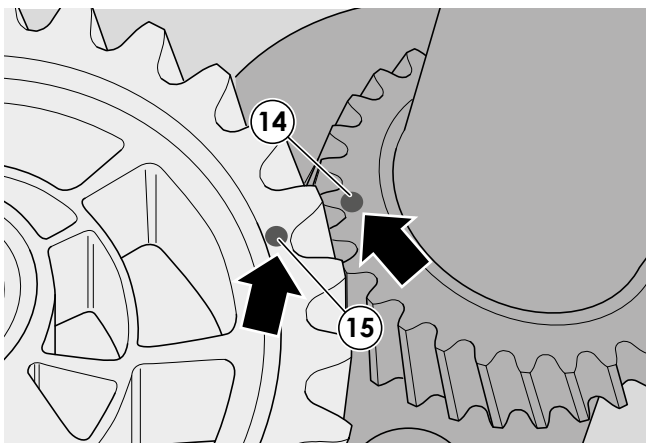

22 - After having fixed the connecting rod cap, take the greatest care to ensure that the two position references (14) and (15) punched on the engine shaft and camshaft gears, coincide, ensuring the correct distribution phasing.

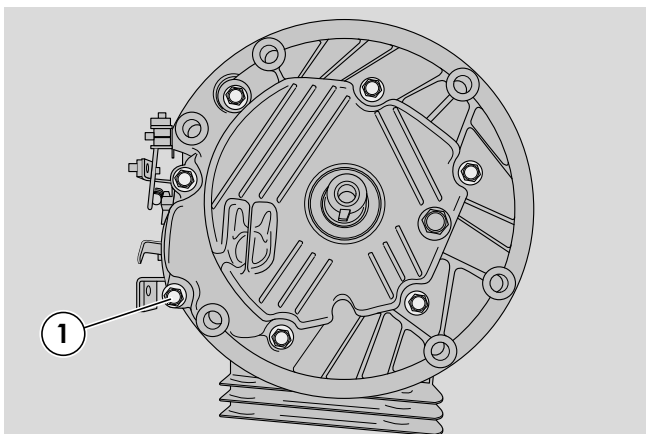

23 - Close the carter and fix the screws (1) to the indicated couple [\[\[🔧 15.1\]\]](#).

24 - Whenever the engine shaft is dismantled and refitted, it is always necessary to:

- replace the sealing ring on the flywheel side [\[\[🔧 14.7\]\]](#);
- replace the sealing ring on the sump side [\[\[🔧 14.8\]\]](#).

25 -  During assembly perform the operations indicated in section [\[\[🔧 15.1\]\]](#) always remembering to replace the washer (2) between the sump and the housing.

15. ENGINE BLOCK - Overhauling internal parts

Tightening torques

1	Union screws under carter and sump	24-32 Nm
12	Counterweight governor fixing screw	5-7 Nm
18	Fixing screws lower connecting rod cap	13-15 Nm

















Technical information

Oil sump capacity	0,5 litres	
Diameter seat of camshaft	13,92 mm	
Diameter aspiration cam	27,30 mm	
Diameter discharge cam	27,45 mm	
Maximum segments gap in the cylinder	1,0 mm	
Max. compression ring axial gap	0,15 mm	
Minimum gudgeon pin diameter	17,95 mm	
Max. gudgeon pin housing diameter on piston	18,05 mm	
Max. connecting rod diameter		
	gudgeon pin side	18,07 mm
	crank side	30,07 mm
Diam. connecting rod's pin on engine shaft	29,92 mm	
Verify the engine shaft extremes	0,10 mm	

Special equipment

- 21** Piston ring removal expander
- 33** Piston ring compressing tool



16. TROUBLESHOOTING

PROBLEM	CAUSE	SOLUTION
The engine does not start or starts badly	Coil earth connection	Check electrical cabling of earth wire  11.2]
	Earth wire is flattened	Replace earth wire  11.2]
	No earth	Check electrical cabling of earth wire  11.1]
	The coil is faulty and does not supply current or the air gap is too large	Check coil  11.2]
	Carburettor dirty	Check and clean the carburettor  8.1]
	Poor seal of carburettor needle valve	Clean the carburettor housing and needle valve  8.1] or replace the carburettor  8.2]
	The spark plug is badly connected or faulty	Check spark  11.1] or replace spark plug
	Blocked air filter	Execute the filter cleaning  7.1]
	Fouling in the combustion chamber	Dismount the cylinder head and remove fouling  14.3]
	Insufficient pressure	Check tightness of cylinder head screws, replace washer if necessary. Check wear and tear of the piston rings  15.3]
	AUTO-CHOKE malfunction	AUTO-CHOKE check and/or replacement  10.1]
	No power supply to battery	Check the alternator  14.6]
Starting motor short circuit (burnt rotor and stator)	Replace starting motor  6.1]	
The engine starts but does not run	Fouling in the combustion chamber	Dismount the cylinder head and remove fouling  14.3]
	Insufficient pressure	Check tightness of cylinder head screws, replace washer if necessary. Check wear and tear of the piston rings  15.3]
	Exhaust is blocked	Check that there is airflow through the exhaust system and replace if necessary  13.1]

16. TROUBLESHOOTING

PROBLEM	CAUSE	SOLUTION
The engine is inefficient or the runs irregularly	The throttle cable is not well adjusted	Check and/or adjust the throttle cable [[🔧 9.1]]
	The governor malfunctions or there is a problem with the rods	Check the entire governor system [[🔧 9]]
	Air seepage in the carburettor	Replace the carburettor gaskets [[🔧 8.1]]
	Carburettor dirty	Check and clean the carburettor [[🔧 8.1]]
	Insufficient pressure	Check tightness of cylinder head screws, replace washer if necessary. Check wear and tear of the piston rings [[🔧 15.3]]
	The coil air gap has been poorly adjusted	Adjust the air gap [[🔧 11.2]] and if the problem persists, replace the coil [[🔧 11.3]]
	Oxidation or loosening of spark plug connections	Perform spark test [[🔧 11.1]] or replace spark plug
	AUTO-CHOKE malfunction	AUTO-CHOKE check and/or replacement [[🔧 10.1]]
The engine overreved	Governor blocked due to breakage of centrifugal assembly or breakage of external governor springs. It is possible that the governor is dirty	Check the entire governor system [[🔧 9 and 15]]
The engine judders	Engine screws loose	Tighten the screws
	Engine timing faulty	Check wear and tear of the connecting rod of the engine shaft, replace shaft if necessary [[🔧 15.3]]
The engine does not turn off	The earth cable is disconnected or broken	Check earthing connection [[🔧 11.1]]
The engine uses a lot of oil	Faulty operation of the oil vent pad	Check and/or replace the oil vent pad [[🔧 14.7]]
	Low resistance of piston ring seal	Replace the rings [[🔧 15.3]]
	Excessive gap between the guide and the inlet valve stem	Check and/or replace the valve [[🔧 14.4]]
	Ring assembly error	Check the assembly of the rings [[🔧 15.3]]

16. TROUBLESHOOTING

PROBLEM	CAUSE	SOLUTION
Starter motor does not run	Flat battery	Check and recharge the battery
	Battery inadequate	Check that the battery corresponds to what is given in the machine specifications.
	Problems with the electric circuit and the devices fitted to the machine	Check all the electrical connections and the efficiency of the control devices fitted to the machine.
	Electrical insufficiency of the starter motor	Replace the starter motor
The starter motor turns but cannot start the engine	Battery insufficiently charged	Check and recharge the battery
	Mechanical inefficiency of the starter motor	Dismantle the motor and clean the pinion zone  6.2
	Broken flywheel	Check and/or replace the flywheel  14.5

