

STIGA



WORKSHOP MANUAL

CUTTING DECKS 2020



95-105 Combi EL QF



100 Combi 3 EL QF



WORKSHOP MANUAL

CUTTING DECKS

95-105 Combi EL QF - 100 Combi 3 EL QF

EDITION 2020

TABLE OF CONTENTS

1 - INTRODUCTION	3
2 - INFORMATION FOR SERVICE CENTRES	7
3 - ASSEMBLY AND REMOVAL	13
4 - MAINTENANCE (95-105 Combi EL QF).....	20
5 - MAINTENANCE (100 Combi 3 EL QF).....	41

INTRODUCTORY NOTES

The purpose of this manual is to provide a complete set of instructions related to the servicing, maintenance, disassembly, repair and installation of the mechanical components for afore-mentioned equipments.

All trained Servicing personnel must use this manual during all adjustment, disassembly and troubleshooting activities.

IMPORTANT NOTE - The information contained herein is destined exclusively to the Service Centres and professional operators, with the required expertise to perform, and use the correct equipment, all the operations described, with the objective of safeguarding machine performance and safety.

The Manufacturer is under no circumstances liable for any damage or injuries due to interventions performed by private individuals or inadequate facilities.

The manual has left out the simplest and quickest operations that can be handled by a good mechanic, while concentrating more on specific aspects with tips and advice on the best servicing procedures.

Please take the time to read through this manual to acquire a basic understanding of the machine, which is necessary for working rationally without making errors or wasting time. All problems related to user procedures are fully covered in the User manual.

All the information provided refers to the original versions of the equipments, excluding therefore interventions on equipments which have been subject to modifications that have altered their characteristics or components.

All brands, names, logos and trademarks mentioned belong to their respective owners.

© by STIGA - No use of the illustrations or duplication, reproduction or translation, even partial, of the texts in this document may be made without explicit authorisation.

1 - INTRODUCTION

Summary

1.1	HOW TO USE THE GUIDE.....	3
1.1.1	Limitation of Responsibility.....	3
1.1.2	Structure of the Manual	3
1.1.3	Symbols and Definitions used	4
1.2	WORK SAFETY INSTRUCTIONS.....	5
1.2.1	Qualification of operators	5
1.2.2	Preparing to work	5
1.2.3	Precautions during servicing	5
1.3	SERVICE CENTRE PROCEDURES	6
1.3.1	Equipment registration	6
1.3.2	Interventions under Warranty.....	6
1.3.3	Exceptions to the use of the Warranty	6
1.3.4	Service repairs outside warranty	6
1.3.5	Fault notification	6
1.3.6	Spare parts requests	6

1.1 HOW TO USE THE GUIDE

1.1.1 Limitation of Responsibility

Despite the efforts made to ensure accuracy in the producing this manual, errors and inaccuracies may be found in the content. The author is not responsible for any missing or incorrect information. The Manufacturer reserves the right to make any modifications to the product without warning or any obligation to promptly update this manual.

The introduction of new procedures or indications in addition to those contained in this Manual are reported to the Service Centres by means of ad hoc bulletins and press releases.

All information contained herein is based on data available at the time of publication.

The drawings and photos included herein, may not correspond exactly to the machine on which the intervention is required.

1.1.2 Structure of the Manual

The manual is divided into chapters, paragraphs and sub-paragraphs.

- The front inside cover provides the table of contents indicating the various chapters.
- Each chapter is dedicated to a specific topic, and is preceded by an index that marks the various paragraphs contained therein.
- Each paragraph is further divided into sub-paragraphs, relative to a single procedure.

Cross-references to other parts of the manual are indicated by the symbol  [...] followed by the relevant chapter, paragraph or sub-paragraph number.

1.1.3 Symbols and Definitions used

a) Symbols

They are used to draw the attention of the operator, reminding him to perform the interventions with the necessary attention and caution.



Indicates operations that should be carried out with utmost care to avoid impairing the functionality and safety of the machine.



Indicates operations that should be carried out with utmost care to avoid injury to operators.

► Highlights all those operations that require different working methods depending on the type of machine, subsequent modifications and accessories fitted.



Indicates the cross-reference to other parts of the manual, followed by the number of the relevant chapter, paragraph or sub-paragraph.

b) Safety terminology and notes

Some paragraphs are preceded by a definition that highlights their importance:

NOTE *General reference for the correct maintenance execution and methods.*

IMPORTANT *Specific procedures or information necessary to avoid damage to the machine or equipment.*

WARNING! *Non-observance will result in the risk of injury to oneself or others.*

DANGER! *Non-observance will result in the risk of serious injury or death to oneself or others.*

c) Spatial references

Whenever reference is made to a position on the machine “front”, “back”, “left” or “right” side, this refers to the positions of the seated operator.

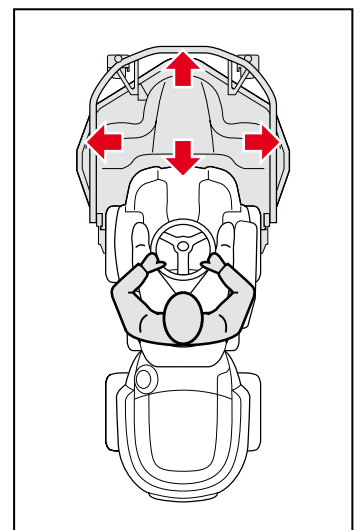

d) Abbreviations and glossary

The following abbreviations are used in this manual

Rh / Lh = Right / Left
Min / Max = Minimum / Maximum
Chap. = Chapter
Par. = Paragraph
PTO = Power takeoff

The terms “Cutting deck” or “Equipment” refer to the cutting-means assembly, connected to the machine PTO by means of a belt.

1.2 WORK SAFETY INSTRUCTIONS

1.2.1 Qualification of operators

All maintenance, disassembly and repairs must be carried out by expert mechanics who are familiar with all the accident prevention and safety regulations after reading through the procedures in this manual.

1.2.2 Preparing to work

Before starting any work, it is very important to provide adequate preparation to achieve more efficient work. A clean work area at the beginning of each intervention allows repairs to be carried out quickly and easily.

To reduce the nuisance of having to search for tools or parts out of place, place the parts removed on a clean work surface, with all the fixing bolts arranged in their order of disassembly.

Organisation is a key element for correct reassembly. The required utensils, tools and components must be gathered before starting work.

Interrupting a job to locate tools or components is a useless waste of time.

1.2.3 Precautions during servicing

The operations described in this manual do not entail particularly hazardous situations besides the normal hazard related to mechanical operations and can be avoided by taking the necessary care and attention normally required for this type of work.

As well as following the usual accident prevention regulations that apply to most repair shops, we recommend you:

- remove the ignition key before beginning any repair work;
- protect hands with suitable protective gloves, especially when working near the cutting unit;
- check that you do not cause accidental petrol leaks or other losses;
- do not smoke when working on the tank or when handling petrol;
- do not inhale oil or petrol fumes;
- clean up all traces of spilt petrol immediately;
- let the engine and exhaust system to cool before starting any repair or maintenance work. The engine and the exhaust system heat up considerably during operation.
- test the engine in a well-ventilated environment or where there are adequate exhaust fume extraction systems;
- do not pollute the environment with oil, petrol or other waste which has a strong impact on the environment. Dispose of all waste in accordance with the laws in force;
- ensure that other persons cannot accidentally carry out actions that may physically endanger those working on the machine.

1.3 SERVICE CENTRE PROCEDURES

1.3.1 Equipment registration

The Warranty registration card must be completed, signed and returned at the time of purchase. This activates the warranty card.

Claims that meet the requirements will be honoured during the limited warranty period.

1.3.2 Interventions under Warranty

The Manufacturer acknowledges the interventions performed under warranty as per the terms, procedures and limits stated in the contract.

1.3.3 Exceptions to the use of the Warranty

- The warranty does not cover damages caused by:
 - Lack of knowledge and familiarisation of the accompanying documentation on the part of the user.
 - Carelessness.
 - Incorrect or prohibited use or assembly.
 - Use of non-genuine spare parts.
 - Use of accessories not supplied or approved by the manufacturer.
- The warranty does not cover components normally subject to wear and tear such as blades, belts and so on.

The purchaser is covered by national legislation of the Country he resides in. The legal rights of the laws that refer to the purchaser are not limited by this product warranty.

1.3.4 Service repairs outside warranty

The Service Centre has to make out a report containing the machine serial number, a summary of the problems, the repairs carried out and any spare parts used for each repair done on the equipment.

A copy of these reports must be retained and made available to the Manufacturer together with the replaced parts in case of any subsequent disputes with Customers.

1.3.5 Fault notification

The Manufacturer welcomes any notifications of faults that recur with particular frequency. It gives the opportunity for a careful inspection of the problem and the implementation of corrective action at production level.

Similarly, the Manufacturer will report any faults discovered on the machines produced, with recommendations for the most suitable procedures for their remedy.

1.3.6 Spare parts requests

When requesting spare parts, the code number must be given, referring to the exploded charts for the year of manufacture, shown on the product identification label.

2 - INFORMATION FOR SERVICE CENTRES

Summary

2.1	GENERAL INFORMATION	7
2.1.1	Equipment identification	7
2.1.2	Safety measures to be adopted.....	7
2.1.3	Basic equipment.....	8
2.1.4	Transportation and handling	9
2.1.5	Tightening torque settings	9
2.2	SPARE PARTS	10
2.2.1	Non-original spare parts	10
2.2.2	Characteristics of the original blades.....	10
2.2.3	Characteristics of the original belts.....	11
2.3	TIPS FOR USERS	12
2.3.1	Cutting height	12

2.1 GENERAL INFORMATION

2.1.1 Equipment identification

Each equipment has a label (1) which shows the technical specifications, the model and the serial number.

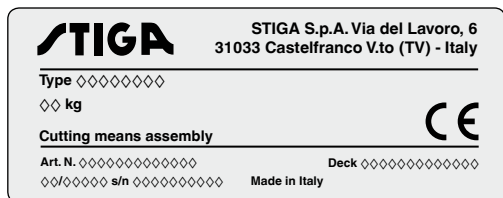

The model and serial number must be shown on each repair sheet when requests are made under Warranty, and are indispensable for spare part orders.

2.1.2 Safety measures to be adopted

All the machines are manufactured in accordance with the strict European safety regulations in force. To maintain these levels of safety in the longer term, the Service Centres should work to this end by making appropriate checks every time there is the chance to do so.

In particular, every time there is work done on the machine the Service Centre should:

- check:
 - all the safety devices function properly, according to the machine on which the equipment has been assembled;
 - that the casings and protection covers have not been removed.

- and also:
 - restore to proper working order any safety devices which have been manipulated or removed;
 - reassemble inefficient, damaged or missing casings and protection covers;
 - replace the protective casings if the engraved pictograms become illegible due to abrasion, cracks or other;
 - clean the inside of the cutting deck with water and a non-metal bristle brush;
 - touch up the painted parts where the paint is scratched or missing;
 - not endorse any repair or modification on the machine or the engine which results in a change in performance or use that is incorrect or different from the purpose for which it was designed and approved;
 - warn the Customer that failure to comply with the above points automatically voids the warranty and the responsibility of the Manufacturer.

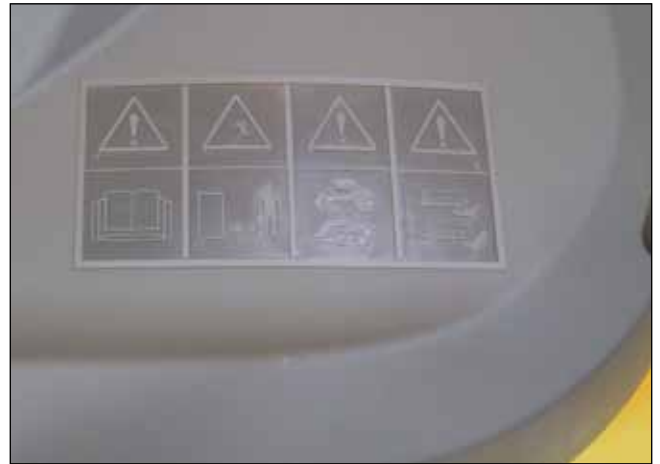

2.1.3 Basic equipment

All the operations can be carried out with the tools normally available at any good motoring Servicing Centre.

Always pay particular attention to the correct tensioning of the toothed belts controlling the blades (For 100 Combi 3 EL QF only).

For this purpose, it is recommended to use a frequency meter (1) capable of providing a correct numerical reading of the level of tension.



To ease the removal or the controlled approach of the pulleys and achieve the correct tension, exceeding the belt load, it can be useful to use a tool (2) obtained from a double screw tensioner with M8 thread, with the ends adapted as indicated in the drawing.

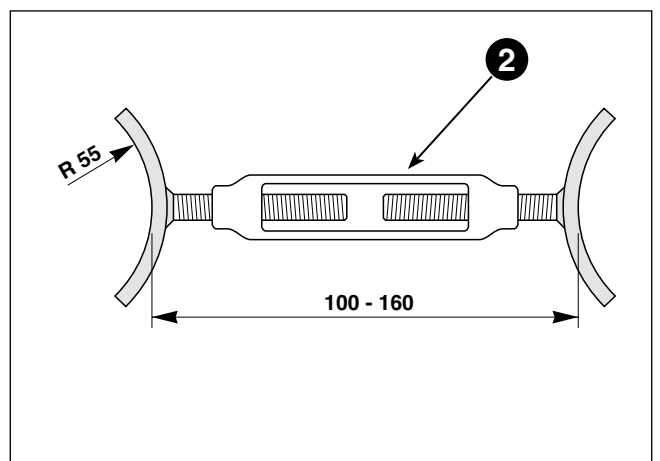

2.1.4 Transportation and handling

Pay utmost attention during the removal and assembly of the equipment on the machine.

! WARNING! - *To lift the equipment using a hoist, use the coupling points shown below, taking into account the total weight of each cutting deck and relative distribution of the same.*

roughly 47 kg (95-105 Combi EL QF)

roughly 55 kg (100 Combi 3 EL QF)

Position the lifting belt or rope around the axle and rear lifting levers on both sides.

Lift with caution, accompanying the rolling of the front wheels on the ground until it reaches the vertical position.

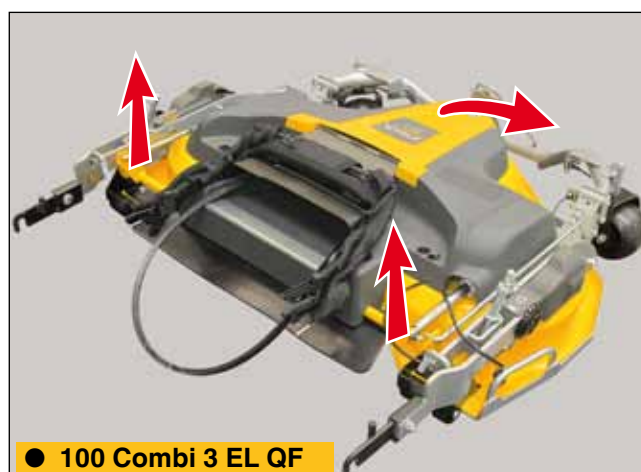
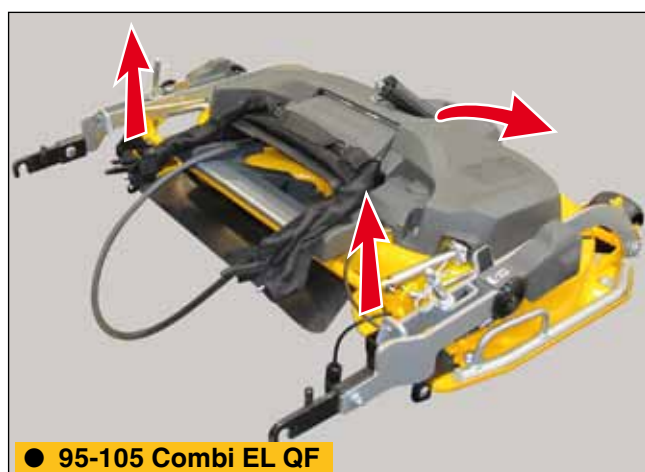
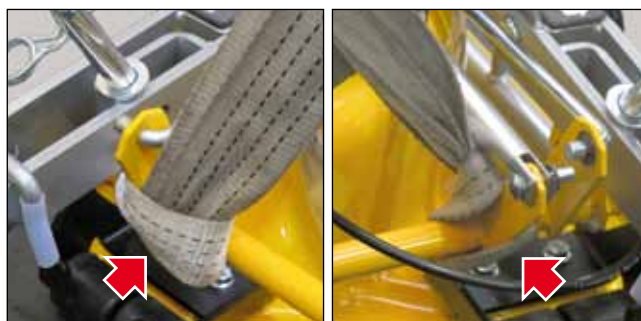

! WARNING! - *Provide adequate stabilisation before carrying out any work on the cutting deck attached to the hoist.*

2.1.5 Tightening torque settings

The table shows the tightening torque settings for screws and nuts to be applied according to their size, except for different situations indicated in the manual regarding a specific procedure.

Threading	Tightening torque
M5	5 Nm
M6	9 Nm
M8	22 Nm
M10	45 Nm

2.2 SPARE PARTS

2.2.1 Non-original spare parts



Use original spare parts only. Replacement of any machine component with anything other than a part authorised by the Manufacturer can adversely affect performance, working life or safety of this machine and will void the Warranty.

The manufacturer disclaims all liability for any claims or damages, albeit under warranty, property damage, personal injury or death resulting from the use of unauthorised spare parts.

2.2.2 Characteristics of the original blades

The original blades have design, material and processing characteristics optimised for use on the equipment for which they were designed; these characteristics are not present in so-called "compatible" spare parts.



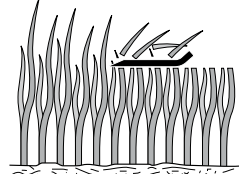

The table emphasises the reasons why it is important to choose an original blade, useful when making such decisions.

Requirement	Remarks
No breakage of the blade ends. 	Using steel balls, the manufacturer simulates what can happen when mowing over any foreign bodies on the lawn. This can ruin the blade edge, but no component can come loose, fall off or be hurled away.
No breakage of the blades. 	The impact test is the most severe durability test that any lawnmower can be subjected to. An iron tube is placed exactly inside the blades when the mower is running. The blade may deform but it will never, under any circumstances, fall off or break. This test verifies that blades and other components meet the high safety requirements.
Excellent balance. Minimum noise. Minimum vibrations. 	The blades and blade ends supplied by the authorised dealer all have exactly the same weight. The blades and blade ends supplied by the authorised dealer are all perfectly balanced. This guarantees minimum noise and vibrations, for maximum machine operating life. This also ensures that the machine complies with the noise and vibration regulations.
Excellent cutting result. 	The blades and blade ends supplied by the authorised dealer are optimised for the application for which they are intended. In short, this means that the blades are suitable for the shape of the casing and to the number of revolutions to provide the best possible cutting result.

2.2.3 Characteristics of the original belts

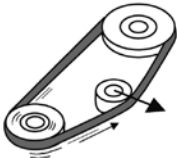
The standard belts on the market have different characteristics compared to the requirements of the original spare belts, supplied by the authorised dealer. The latter are designed and manufactured in close cooperation with the belt supplier and the machine manufacturer.

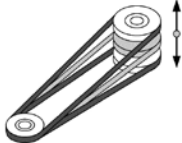
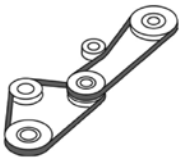
The table emphasises the reasons why it is important to choose an original belt, useful when making such decisions.

Example	Belts available on the market	Original spare belts	Notes
Adhesion on the pulley. 	The belt rests with the sides inclined against the walls of the pulley. There must be a gap between the belt and the bottom of the groove.	The belt rests with the sides inclined against the walls of the pulley. There must be a gap between the belt and the bottom of the groove.	Same requirements. The original spare belts ensure perfect adhesion on the pulley.
Acceleration. 	Some belts only engage with the pulleys when the engine is running at operating speed and this generates excessive heat.	The belt follows the speed of the engine in continuous acceleration until the maximum speed is reached.	Standard belts are made of natural rubber and only capable of withstanding temperatures up to 70°C. Original spare belts are made of chloroprene rubber capable of withstanding temperatures up to 90°C.
Length. 	Manufactured in standard interval lengths.	Made in a specific length designed to ensure perfect adhesion to the pulley.	The distance between the pulleys is fixed. The belt tensioner ensures that the original belt maintains optimal tension.
Floating pulley on cutting equipment. 	Designed to transmit power between aligned, parallel and fixed pulleys.	The original Power Take Off (PTO) belt is designed to work even if the pulleys move up and down and tilt at the same time.	The equipment follows the ground beneath it and this means that the pulley is constantly moving. To withstand extreme operating conditions, the original belts are made of fibre reinforced rubber.
Curvature in two directions. 	Designed to curve around the pulley in one direction.	Most of the belts installed on the machines have tensioning rollers that act on the outer side of the belt. This means that while the belt is being used it must tilt both inwards and outwards.	All the original belts, which work with tensioning arms acting on the external side, are equipped with reinforcements. The reinforcement is designed specifically for these specific cases.
Noise. 	Made without special requirements for this specific factor.	The original belts are carefully selected to limit the increase in noise produced by the machine during operation.	Depending on the function, one of the following belt types is suitable: <ul style="list-style-type: none"> • Coated • Anti-friction • Open sided

2.3 TIPS FOR USERS

2.3.1 Cutting height

The best cutting results are obtained when cutting the upper third of the grass, meaning that 2/3 of the length of the grass remains on the lawn.

If the grass is very long and requires more height to be removed, it is recommended to mow the lawn twice at different heights.

Do not use the lowest cutting heights if the lawn surface is not even. This would result in a risk of damaging the blades due to impact with the ground and removing the surface layer of the ground.

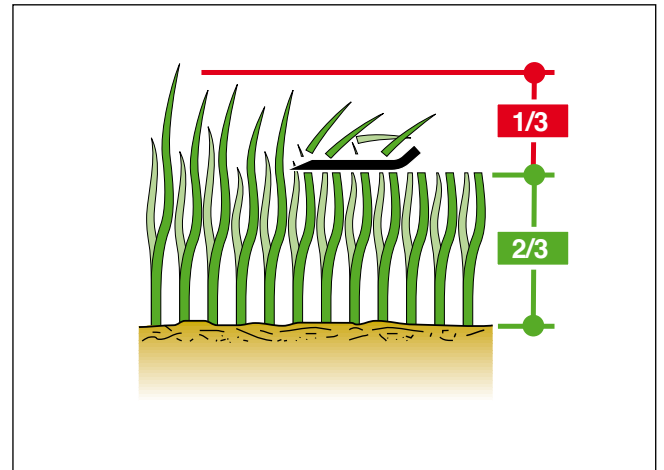

3 - ASSEMBLY AND REMOVAL

Summary

3.1	UNPACKING AND COMPLETING THE EQUIPMENT	13
3.1.1	General information.....	13
3.1.2	Assembling the coupling hooks	13
3.1.3	Basic height adjustment	14
3.1.4	Assembly of the spring	15
3.1.5	Replacing the belt (for the Park 2WD machine only)	15
3.2	PREPARE THE MACHINE	17
3.2.1	Mounting the interface bracket	17
3.3	INSTALLING THE EQUIPMENT ON THE MACHINE	17
3.3.1	Coupling and connection of the equipment to the machine	17
3.3.2	Connecting the belt to the machine PTO	19
3.4	REMOVING THE EQUIPMENT FROM THE MACHINE	19
3.4.1	Disconnecting and removing equipment from the machine	19

3.1 UNPACKING AND COMPLETING THE EQUIPMENT

3.1.1 General information

For transport and storage reasons, the cutting deck is delivered with some parts separate, to be assembled before applying the equipment to the machine.

IMPORTANT *All operations must be carried out on a flat and solid surface, with sufficient room for manoeuvres, wearing protective gloves and always using the appropriate tools.*

Remove the contents from the packaging, taking care to collect the various elements and hardware provided, to avoid losing them.

IMPORTANT *The packaging elements must be disposed of according to the local regulations in force, taking into account the different materials.*

3.1.2 Assembling the coupling hooks

Fit the two coupling hooks (1) inside the arms (2), taking care to respect the left and right position, then fasten them in place using the screws (3) and nuts (4).

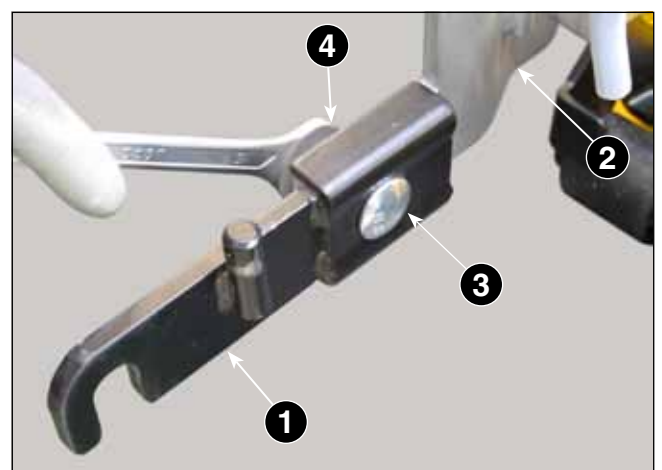

3.1.3 Basic height adjustment

IMPORTANT This adjustment is *ONLY* foreseen to check the ratio of the base height of the cutting deck in standard operating conditions which foresee the simultaneous mulching of the grass cuttings.

NOTE The equipment is delivered with factory default settings for use in mulching mode.

The basic adjustment involves a slight forward inclination of the cutting deck, raising the rear edge by about 5 mm compared to the front, the optimal condition to ensure even cutting and simultaneous mulching of the grass inside the cutting decks.

If the mulching function is not required in favour of the rear ejection of the mown grass, it is necessary to remove the internal rear deflector (1) of the cutting deck.

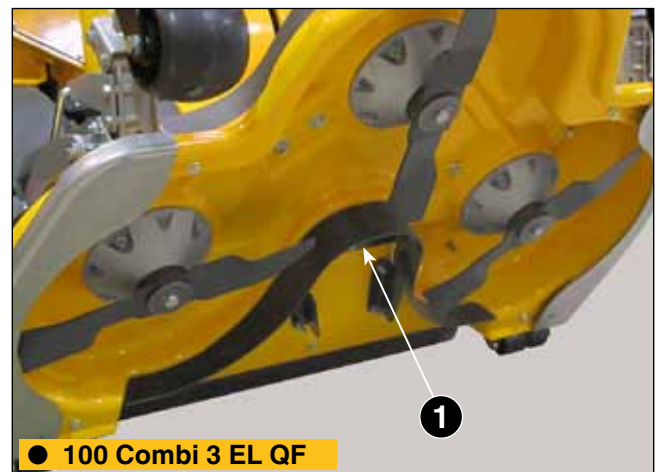
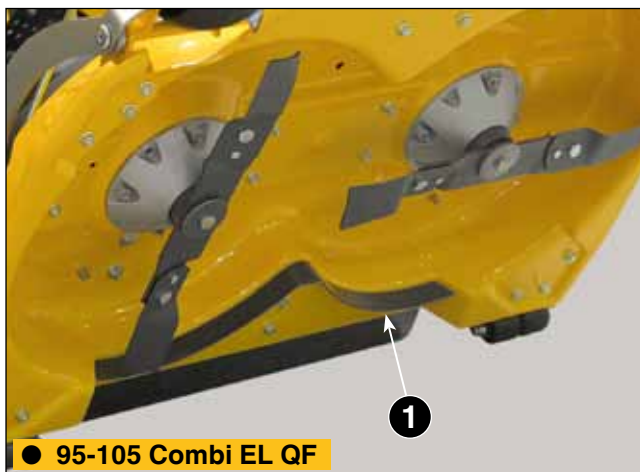

To adjust the rear end height:

1. Lower the cutting deck.
2. Pull the “Quick Flip” knob (1) to release the rear end of the cutting deck from the support arms.
3. Use a screwdriver to remove the split pin (2).

4. Reposition the split pin in one of the three holes provided on the pin (3), applying this rule:
 - Centre hole = “Mulching” Mode
 - Bottom hole = Rear grass discharge

NOTE Never use the top hole.

5. Return the knob (1) to the working position.

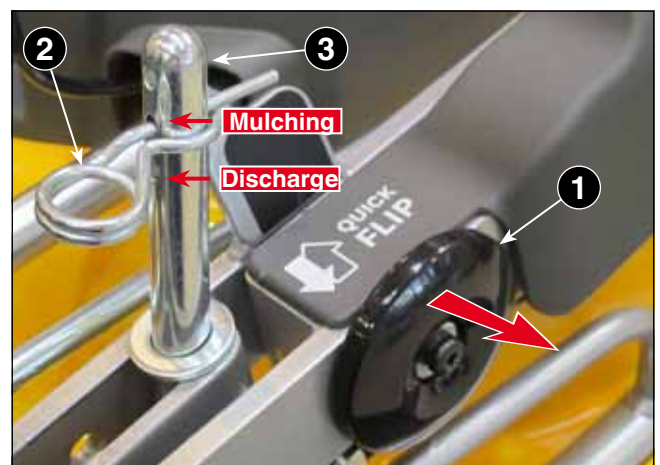

3.1.4 Assembly of the spring

● **95-105 Combi EL QF:**

- Hook the spring clasp (1) onto the relevant hole (2) accessible through the specific opening in the protective casing.



● **100 Combi 3 EL QF:**

- The spring is preassembled on the cutting deck.

3.1.5 Replacing the belt (for the Park 2WD machine only)

NOTE The equipment is delivered with a belt already assembled and suitable for use on the Park 4WD machine.

For use on Park 2WD machines, the preassembled belt must be replaced with the one supplied, following the procedure below.

● **95-105 Combi EL QF:**

- 1. Unscrew the four screws (1) and remove the guard (2).
- 2. Remove the belt (3) from the pulley (4) and replace it with the longer belt supplied:
 - 4WD = Short belt
 - 2WD = Long belt
- 3. Reassemble everything following the steps described above in reverse order, making sure to fit the rear side walls of the guard (2) in the container grooves (5) correctly.

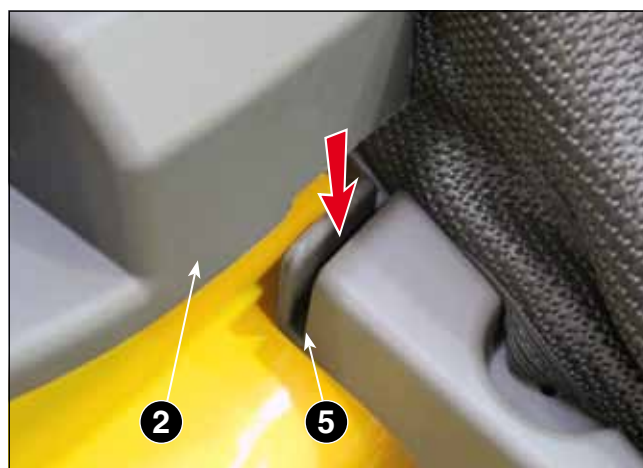
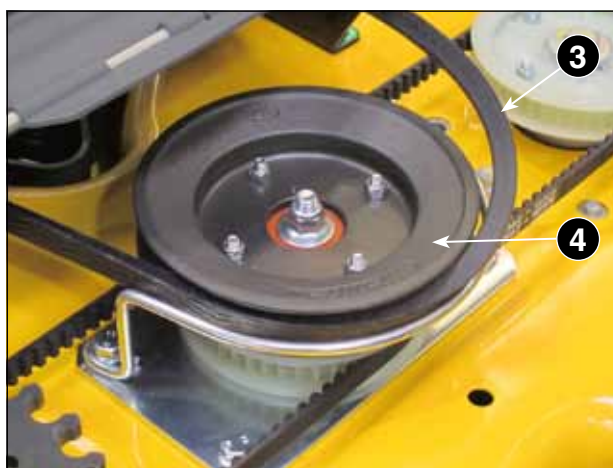

● **100 Combi 3 EL QF:**

1. Loosen the fixing screw (1) on the guard (2).



2. Remove the guard (2) by lifting it from the front.



3. Remove the belt (3) from the pulley (4) and replace it with the longer belt supplied:
 • 4WD = Short belt
 • 2WD = Long belt



4. Reassemble everything following the steps described above in reverse order, making sure to fit the four rear flaps (5) of the guard (2) correctly in their seats.

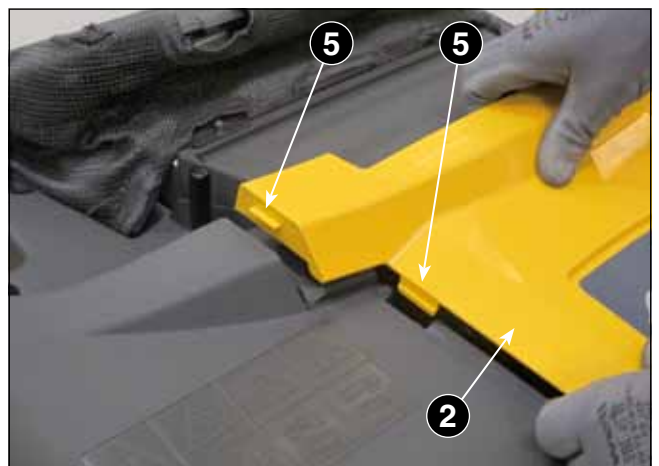

3.2 PREPARE THE MACHINE

3.2.1 Mounting the interface bracket

1. Undo the two screws (1) already pre-assembled in the lower part of the front of the machine.
2. Mount the supplied interface bracket (2), using the same screws (1).

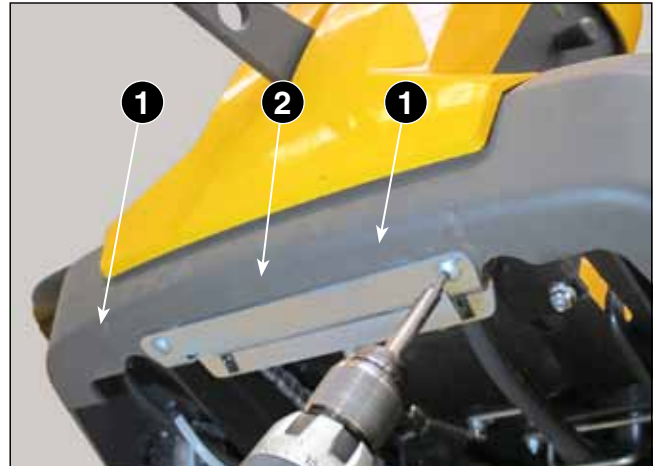
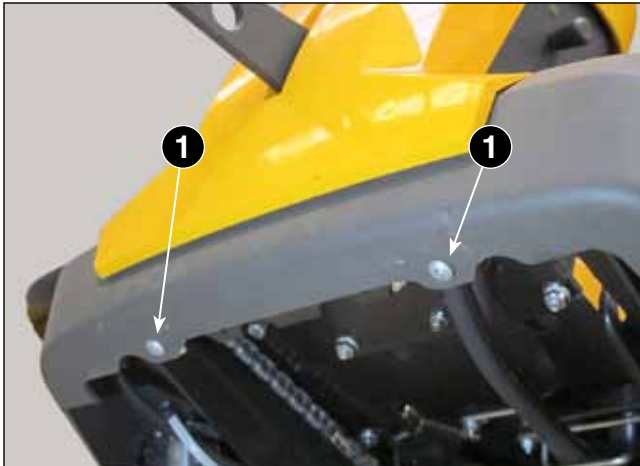

3.3 INSTALLING THE EQUIPMENT ON THE MACHINE

3.3.1 Coupling and connection of the equipment to the machine

Approach and align the equipment in relation to the front of the machine.

NOTE All the following operations must be performed from both sides of the equipment.

1. Rotate the two quick release levers (1) backwards.

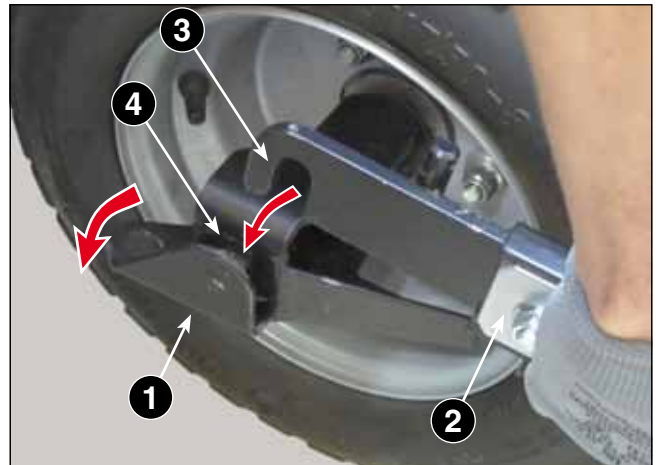

2. Keeping the arm (2) raised, approach the equipment to the machine until the coupling slot (3) is in line with the pin (4).
3. Lower the arm so that the slot (3) couples with the pin (4), then rotate the lever (1) as far forward as possible.

4. Release the two quick release levers (1) using the safety split pins (5).

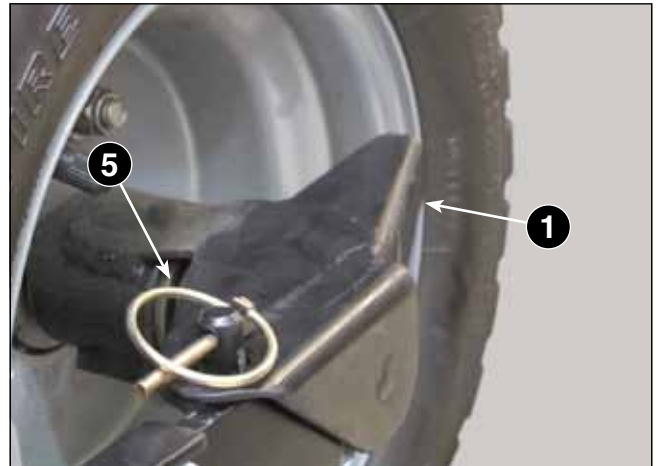

5. Couple the two fork terminals (6) of the belt guard (7) to the two pins (8) located inside the front wheels of the machine.

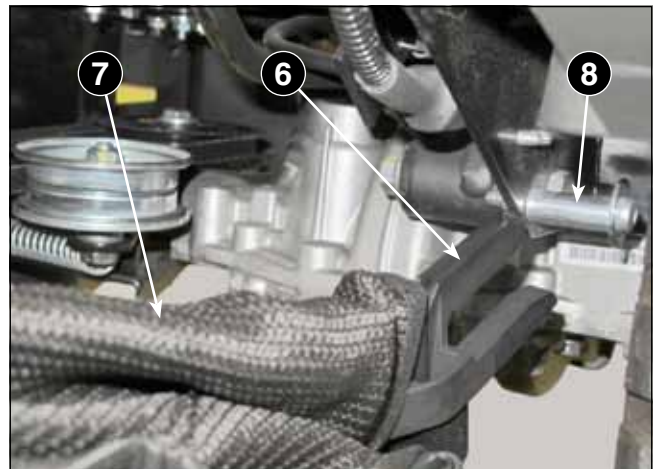

6. Position the guard (7) frame (9) in line with the interface bracket (10) and fasten in place with the two screws (11).

7. Connect the cutting height adjustment control coupling (12) to the plug (13) on the lower right side of the machine.

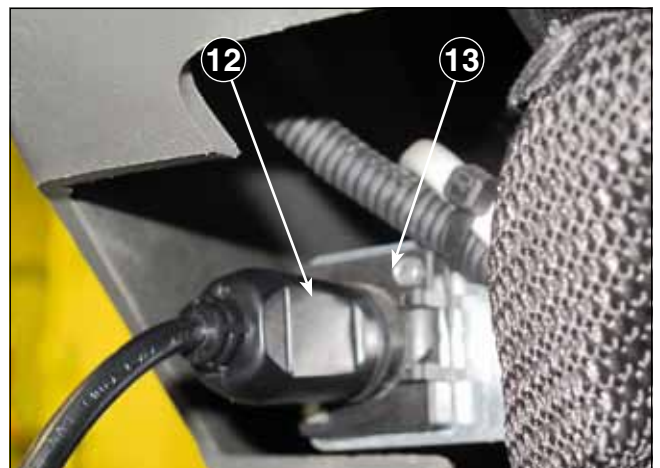
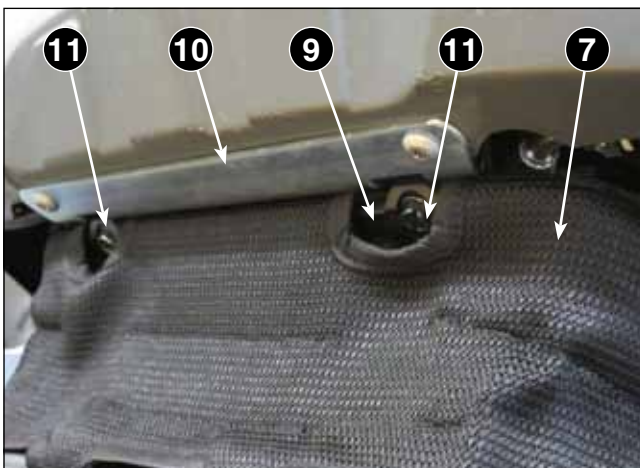

8. Keeping the front part of the deck slightly raised, connect the spring clasp (14) to the front hole of the machine lifting lever (15).

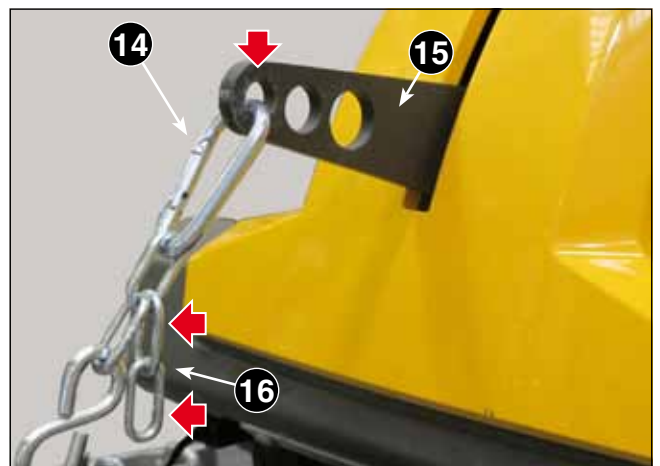

NOTE Standard user conditions foresee the hooking of the chain leaving two links unused (16); with a single link free, the cutting deck adapts to the unevenness of the ground more easily, while three free links make it more rigid.

3.3.2 Connecting the belt to the machine PTO

1. Pull the lever (1), located in the lower right part of the machine on the left side (Park 2WD) or right side (Park 4WD), so as to distance it from the tensioner (2).
2. Wrap the PTO belt (3) onto the pulley (4) making sure that the left branch remains inside the tensioner (2).
3. Disengage the lever (1).

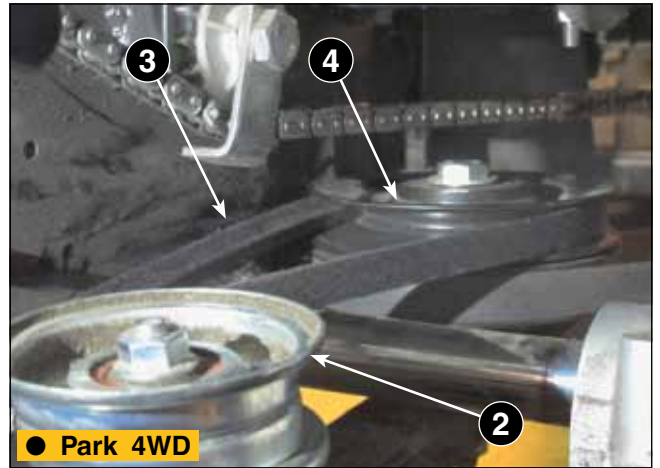
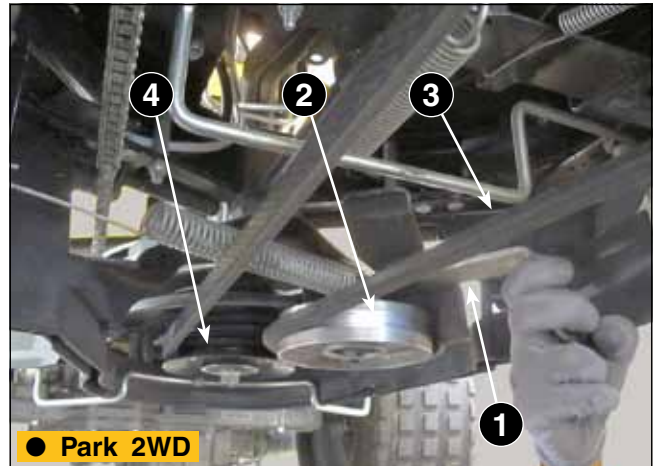

3.4 REMOVING THE EQUIPMENT FROM THE MACHINE

3.4.1 Disconnecting and removing equipment from the machine

Perform the following procedures in reverse order, as described above:

- Disconnect the PTO belt. [👉 3.3.2] from 3 to 1.
- Remove all mechanical and electrical connections. [👉 3.3.1] from 8 to 1.

4 - MAINTENANCE (95-105 Combi EL QF)

Summary

4.1	TROUBLESHOOTING	20
4.2	REPLACING OF GUARDS	21
4.2.1	Replacing the belt guard canvas	21
4.2.2	Replacement of the intermediate guard.....	23
4.3	REPLACING THE BELTS	24
4.3.1	Replacement of the control belt.....	24
4.3.2	Replacing the blade connecting belt	25
4.4	REPLACING AND REGULATING THE LOCKING DEVICE.....	27
4.4.1	General information.....	27
4.4.2	Replacing the locking device and adjusting the cable	27
4.5	BLADES AND SHAFT SUPPORTS.....	30
4.5.1	Removing and reassembling the blades.....	30
4.5.2	Sharpening and balancing the blades	31
4.5.3	Check the alignment of the blade shafts.....	32
4.5.4	Replacement of the blade supports and shafts	33
4.6	REPLACING THE HANDLE CABLES	34
4.6.1	General information.....	34
4.6.2	Replacing the cable.....	34
4.7	FRONT WHEELS	36
4.7.1	General information.....	36
4.7.2	Replacement of the bushings.....	36
4.8	GENERAL MAINTENANCE	37
4.8.1	Routine maintenance chart	37
4.8.2	Lubrication	37
4.8.3	Washing and cleaning	38

4.1 TROUBLESHOOTING

NOTA *The table below provides a guide on how to identify the origin of an anomaly and which section of the Manual deals with such aspects.*

Problem	Probable cause	Solution
1. Worn belt protection canvas	Wear and/or contacts with other elements	Replacement of the belt protection canvas [4.2.1]
2. Damaged belt protection	Contact with other elements	Replacement of intermediate protection [4.2.2]
3. The cutting means do not engage or do not stop promptly when they are disengaged	Wear/breakage of the control belt	Replacement of the control belt [4.3.1]
	Wear/breakage of the blade connection belt	Replacement of the blade connection belt [4.3.2]

Problem	Probable cause	Solution
4. The blade locking device has been triggered with the blades still rotating	• Malfunction of the locking devices	Replacement of the locking device and adjustment of the cable [👉 4.4.2]
	Cable breakage	
5. The blades rotate in the maintenance/wash position	Cable not adjusted	Replacement of the locking device and adjustment of the cable [👉 4.4.2]
	Cable breakage	
6. Abnormal vibration and / or irregular cutting	Loose parts.	Tighten all fastening devices Tightening torque [👉 2.1.5]
	Damaged cutting means.	Sharpening and balancing the blades [👉 4.5.2] Check the alignment of the blade shafts [👉 4.5.3]
7. No cutting height adjustment	Electric motor malfunction	Check electric connection Replace the electric motor
8. Front wheels locked	Worn or damaged parts	Replace worn or damaged parts [👉 4.7.2]

4.2 REPLACING OF GUARDS

4.2.1 Replacing the belt guard canvas

WARNING! - *The integrity of the belt guard canvas is an essential condition for the safety of the machine and equipment. Always replace the canvas at the first signs of wear or tear.*

1. Remove the cutting deck from the machine, following the following procedures in reverse order:
 - Disconnect the PTO belt. [👉 3.3.2] from 3 to 1.
 - Remove all mechanical and electrical connections. [👉 3.3.1] from 8 to 1.

2. Release the two positioning cables (1) from the lower frame (2) of the guard, connecting each terminal to its designated seat taking care not to drop them inside the casing underneath.

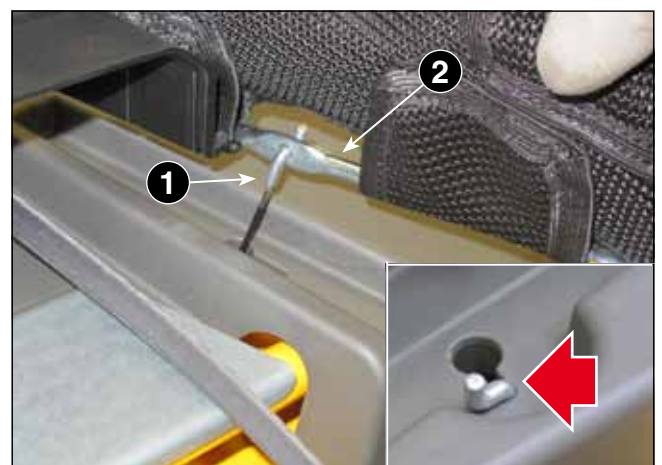

3. Undo the two screws (3) that fasten the canvas belt guard (6) protection supports (4) on the frame (5) to the intermediate guard (7).

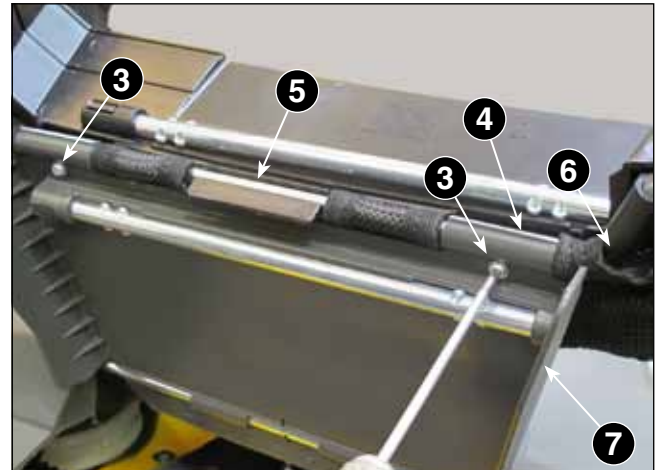

4. Rotate the outer side of the supports (4) to release the frame (5).

5. Release all plastic profiles (8) that fasten the canvas (6) to the frame (5).

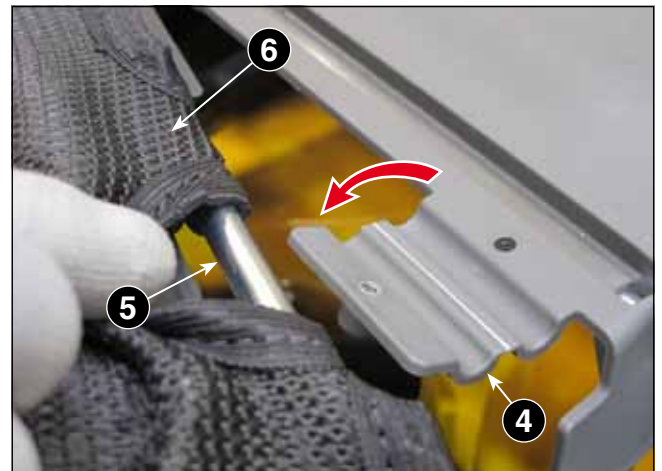

6. From the upper part of the guard, extract the two elastic eyelets (9) from their respective seats (10).

7. Using a suitable pair of pliers, release the retaining tabs (11) on the inside and remove one of the two forks (12).



8. Remove the canvas from the frame.

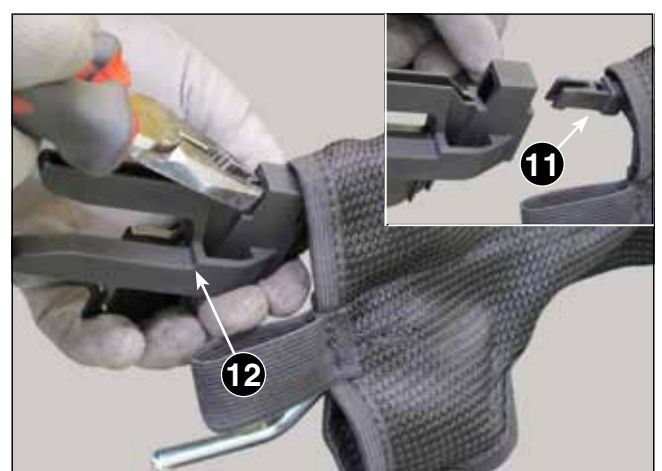

Reassemble the new canvas and fasten the guard following the above procedures in reverse order.

- Before tightening on the two support (11) screws (10), make sure that the plastic tab (13) of the canvas guard remains inside the perimeter of the intermediate guard (7).

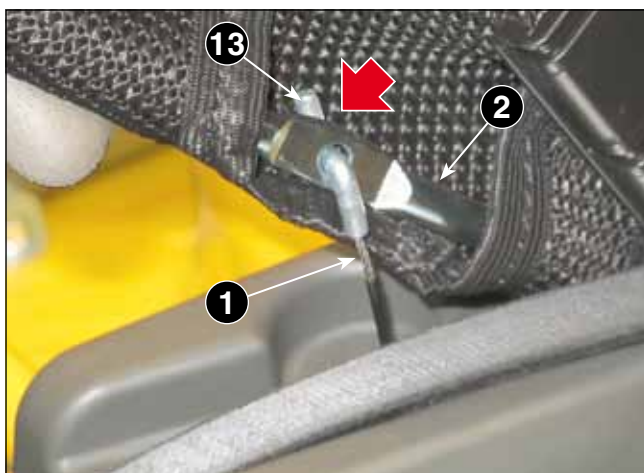

When reconnecting the cables (1) to the frame (2), make sure that the two terminals (13) are inside with respect to the frame.

4.2.2 Replacement of the intermediate guard

1. Unscrew the four screws (1) and remove the upper guard (2).



2. Use a screwdriver to remove the two snap rings (3) and push the pin (4) to the left to remove it from the two supports, together with the intermediate guard (5).

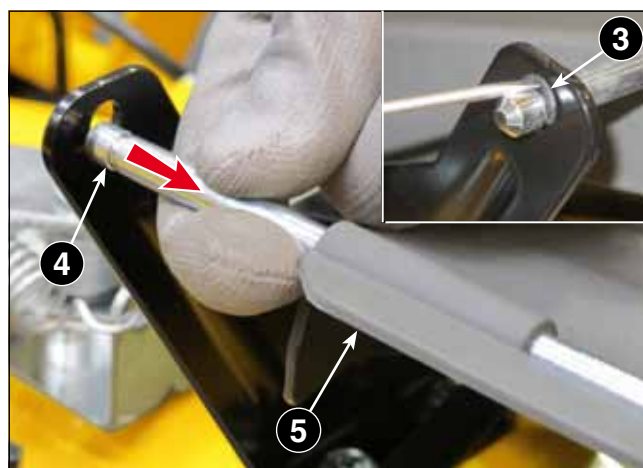

3. If only the plastic part of the guard is being replaced, the two pins must be recovered and reassembled on the new guard:

- Using a screwdriver, remove the central snap ring (6) and followed by the front pin (7).

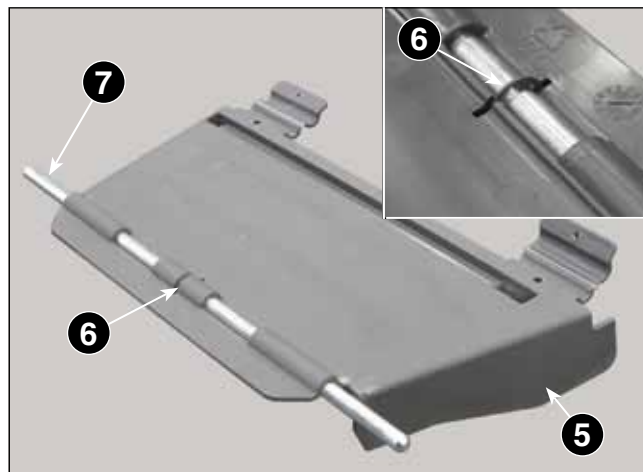
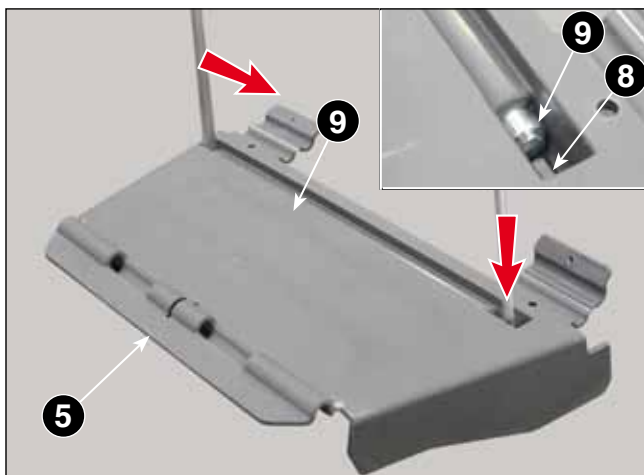

- From the outside of the guard, press the tab (8) located on the left side with a screwdriver and, keeping it pressed, use a second screwdriver on the right side to push the rear pin (9) to the left, until it can be removed.

IMPORTANT *The function of the rear pin (9) is to prevent accidental sliding of the belt on the internal surface of the guard and therefore must always be reinstated if a guard is replaced.*

4. Assemble the rear pin (9) by first inserting one end into the left seat and then sliding it to the right until the internal tab (8) clicks into place.

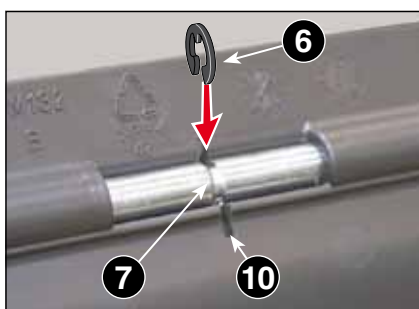
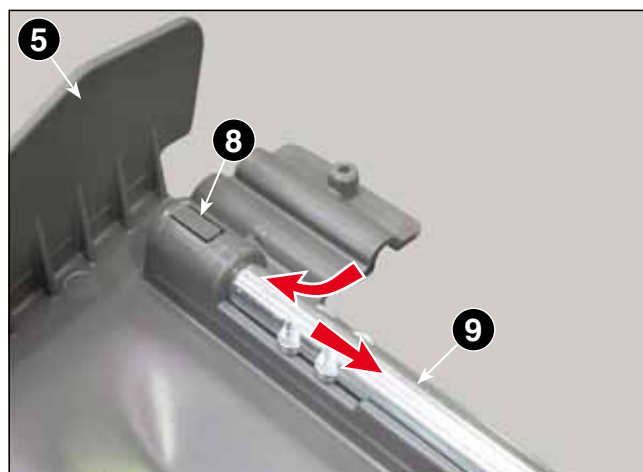

Reassemble the new guard by following the procedures described above in reverse order, taking care to align the opening (10) on the intermediate guard with the groove on the pin (7) and reassemble the snap ring (65), making sure that it remains fully inserted in its seat.

4.3 REPLACING THE BELTS

4.3.1 Replacement of the control belt

NOTE *The replacement of the control belt can be performed without having to remove the cutting deck from the machine.*

- Disconnect the belt from the PTO by following the relative procedure in reverse order. [👉 3.3.2] from 3 to 1.
- Replace the belt following the relative procedure which differs according to the type of cutting deck. [👉 3.1.5] from 1 to 4.

4.3.2 Replacing the blade connecting belt

NOTE *The replacement of the blade connecting belt can be performed both with the cutting deck connected to the machine and also to the bench; this latter solution is however preferable as it allows better accessibility and ease of operation.*

The following operations are easier to perform if the cutting deck is in the minimum height position «1».

If the plate was removed from the machine set at a different height, it is possible to intervene by connecting the electric control connector to an external 12 Volt battery, until the desired working condition is obtained.

- Remove the cutting deck from the machine [👉 3.4.1].
- Remove the canvas guard [👉 4.2.1] from 1 to 3.
- Remove the intermediate guard [👉 4.2.2] from 1 to 5.



1. Undo the four screws (1) and remove the guard (2).

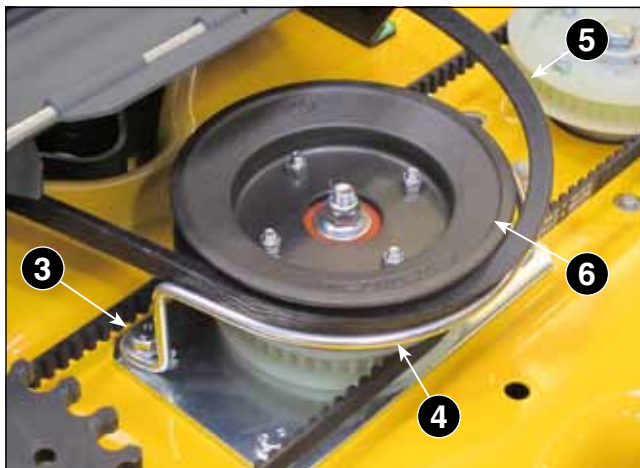

2. Undo the two screws (3), remove the belt guide (4) and remove the control belt (5) from the pulley (6).

3. Loosen the four screws (7) enough to allow the left pulley axle to move (8) and remove the left belt (9) from the relative pulley.

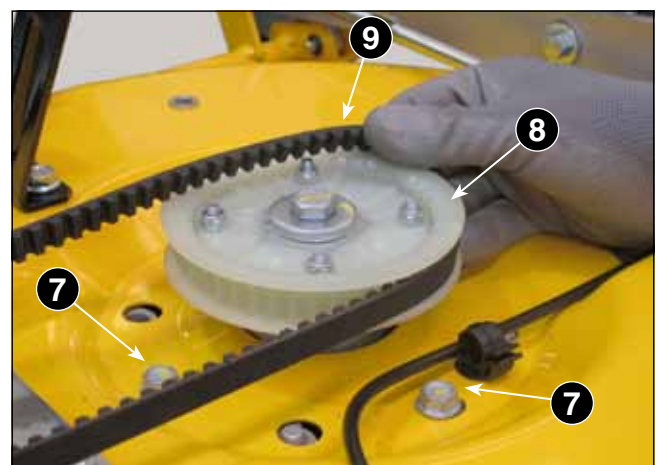

- Loosen the four screws (10) enough to allow the right pulley axle to move (11) and remove the right belt (12) from the central part of the pulley (13).

To reassemble, follow the operations described below in the indicated order.

- First assemble the right belt (12), connecting it to the lower pulley (13) on the central axle and then assemble the left pulley (9).

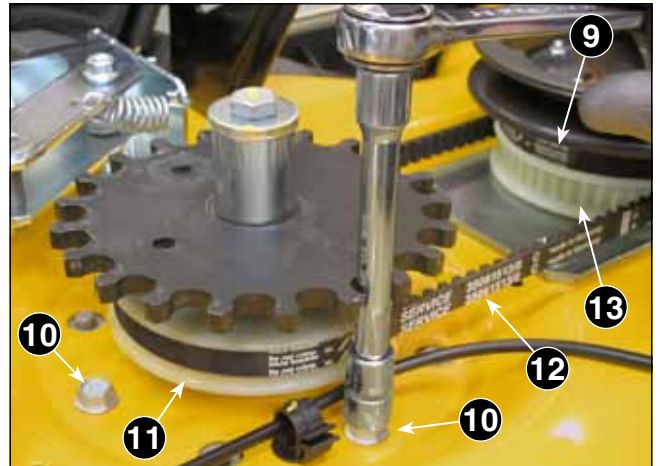

! IMPORTANT *The blade traces overlap and therefore it is fundamental to synchronize them in order to prevent physical interference of the blades while rotating causing damage and dangerous situations.*

- Check the correct synchronisation of the blades.
In the correct condition, the arrows on the hubs must be turned in the opposite direction to each other as shown in the image. If the torque limiter is released or the blades are not perfectly aligned at 90 degrees, the arrows do not point in the opposite direction. In this case, loosen the screws (7 or 10) and slide the teeth of one of the two pulleys with respect to the relative belt (9 or 12) until correct synchronisation is achieved.

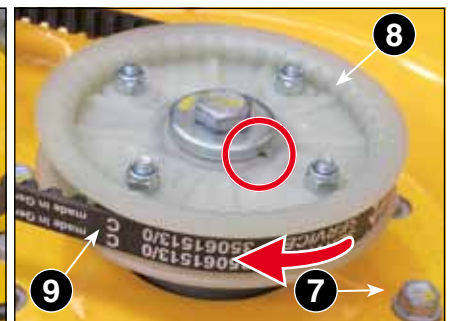
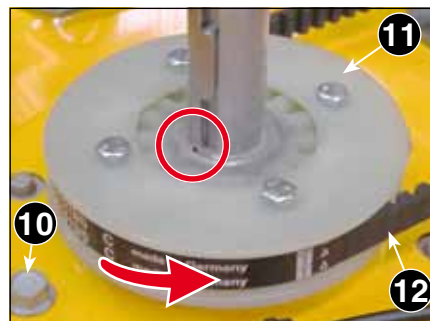
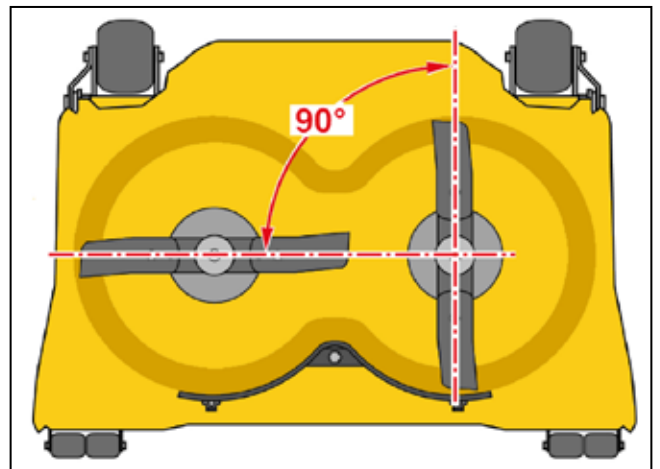

- After achieving synchronisation, replace screws (7) and (10) without fully tightening them.
- Tighten each belt using an ad hoc tensioner (14) [👉 2.1.3] and check the tension with a frequency meter placed approximately 10 mm from the belt (15); the correct tension is obtained with a value of:

- 128 Hz ± 5% = 95 Combi EL QF.
- 122 Hz ± 5% = 105 Combi EL QF.

Alternatively, the correct tension can be achieved by applying a tensile strength of approximately 300 N on the axis of each pulley.

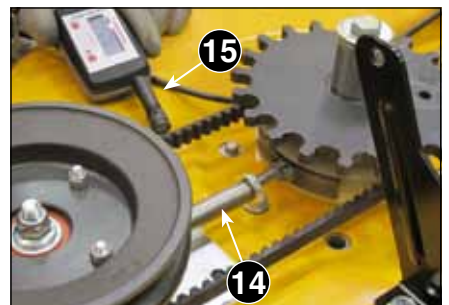

- After achieving correct tensioning, tighten screws (7) and (10) with a torque wrench set to 22-28 Nm.

4.4 REPLACING AND REGULATING THE LOCKING DEVICE

4.4.1 General information

The locking device has the purpose of blocking the rotation of the blades if the cutting deck is accidentally moved to the washing position with the blades engaged.

! WARNING! - *This device is an integral part of the safety devices of the machine and therefore must always be kept in perfect working order.*

Repeated interventions on the device, due to incorrect use, can deteriorate the teeth of the toothed wheel and damage the engagement cable.

For this reason, in case of intervention, it is necessary to restore the original factory settings, replacing all the parts shown in the diagram which constitute the essential elements of the mechanism.



4.4.2 Replacing the locking device and adjusting the cable

1. Prepare the cutting deck according to the following procedures:

- Remove the cutting deck [👉 3.4.1].
- Remove the canvas guard [👉 4.2.1] from 1 to 3.
- Remove the intermediate guard [👉 4.2.2] from 1 to 5.

2. Undo the four screws (1) and remove the guard (2).

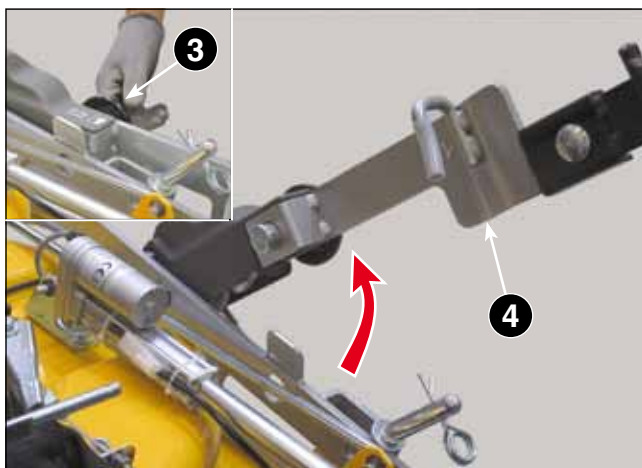

3. Pull the "Quick Flip" knob (3) to release the right support arm (4) and lift it as far as possible to reduce the tension of the cable.

IMPORTANT *Do not lift beyond the stop point so as to avoid anomalies in the coupling system.*

4. Undo the screw (5) and remove the washer (6) and the spacer (7).

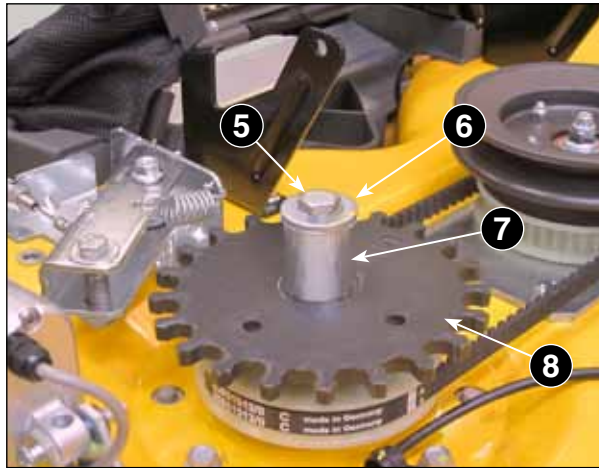

5. Remove the toothed wheel (8), using an extractor (9) if difficulties are encountered.

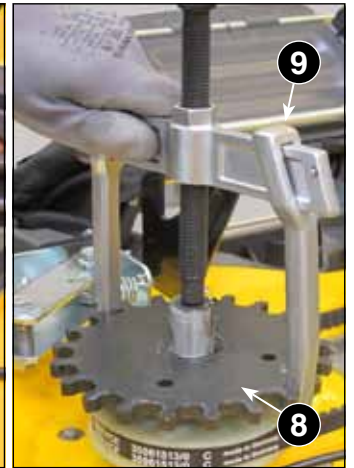

6. Release springs (10) and (11).

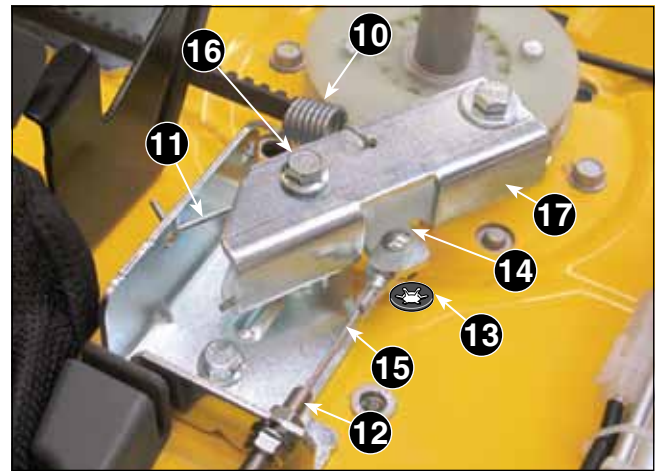

7. Loosen the adjuster (12), remove the elastic ring (13), remove the pin (14) and disconnect the cable (15).

8. Undo the screw (16) and remove the lever (17), leaving the support bracket in place.

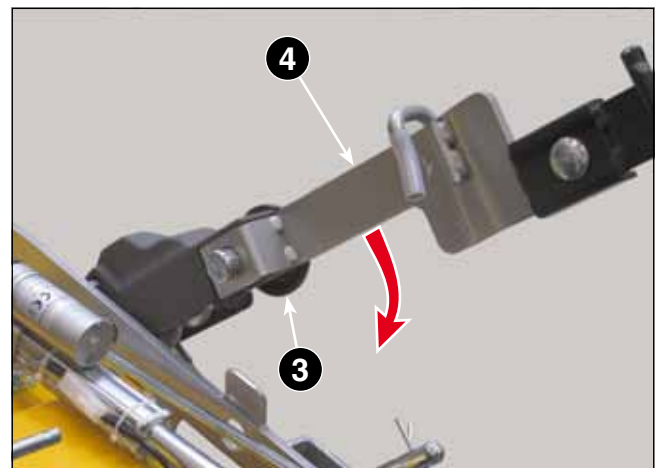

9. Lower the right arm (4) and make sure that it is secured in place by the pin on the "Quick Flip" (3) knob.

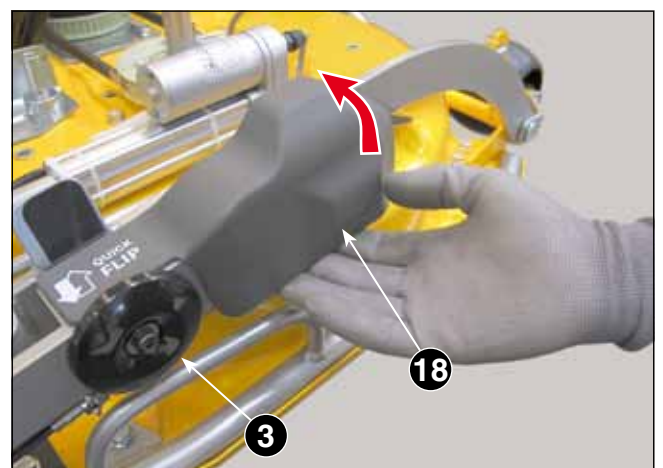

10. Remove the casing (18), lifting it from the front.

11. Unhook the retainer plate (19) and extract the pin (20) supporting the cable terminal eyelet (21).

12. Loosen the nut (22) and remove the cable (21).

13. Disassemble all the parts of the leverage system, keeping all the parts highlighted in grey in the drawing, in order to reuse them and reassemble the system with the spare parts used to replace those that are no longer usable for safety reasons.

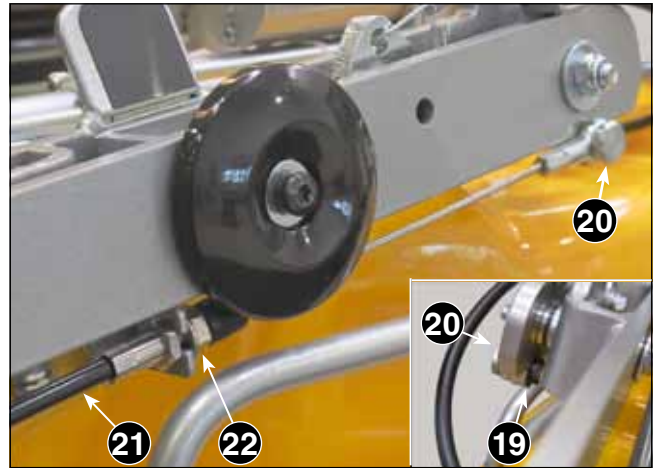

To reassemble, follow the operations from 13 to 4 in the reverse order, taking care to:

- fit the new crown (8) with the «UP» marking facing upwards;
- tighten the screws (5) using a torque wrench set to 22-28 Nm.

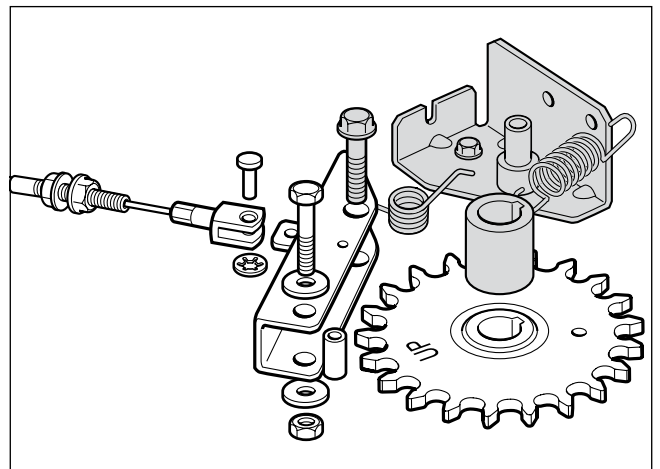

14. With the right arm raised, screw the upper adjuster (22) as far as possible and carefully replace the protection cap (23).

15. Lower the right arm and adjust the lower adjusting nut (12) to obtain a distance of 24-26 mm between the teeth of the crown (8) and the lock roller (23).

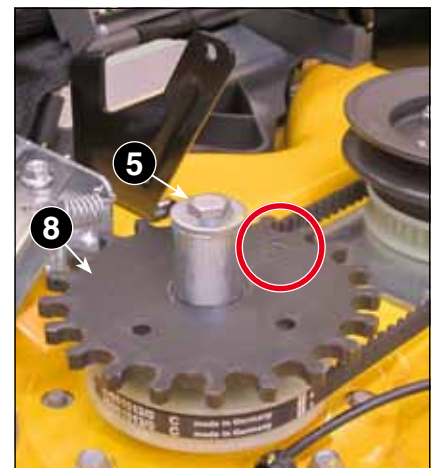

Complete the assembly following the operations from 3 to 1 in the reverse order.

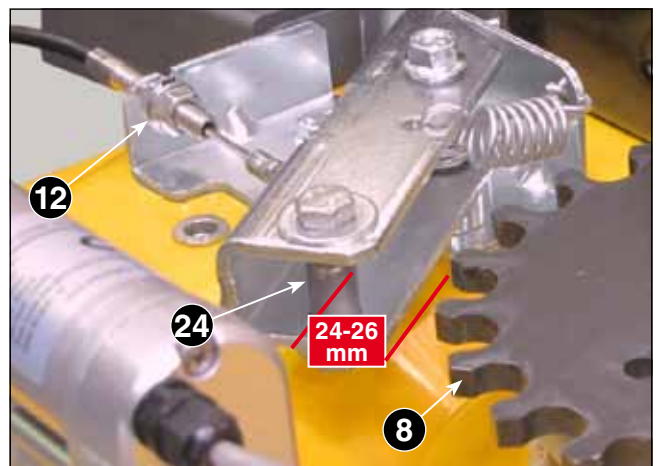
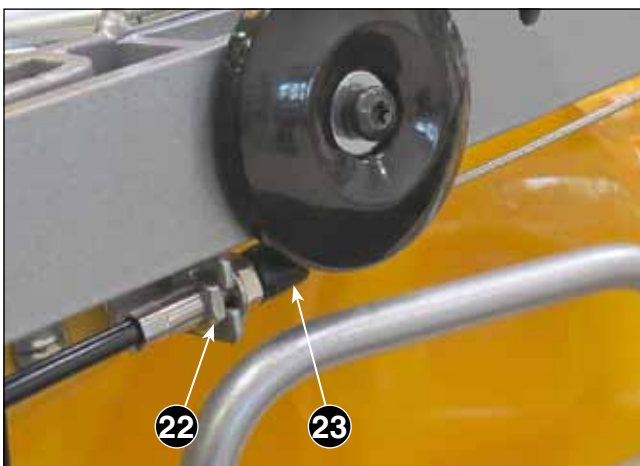

4.5 BLADES AND SHAFT SUPPORTS

4.5.1 Removing and reassembling the blades

NOTE *Interventions on the blades can be performed with the cutting deck applied to the machine, adjusted to the minimum cutting height «1» and set to the "Maintenance / Washing" position.*

To do so, pull the two "Quick Flip" knobs (1), use the two front handles (2) and lift the cutting deck (3) as far as the release point, making sure it is stable before proceeding with further interventions.



! WARNING! - Apply the machine parking brake and check the stability of the cutting deck before starting any intervention.

! WARNING! - Always wear protective gloves when handling the blades.

! WARNING! - The blades are connected to each other. The rotation of each blade engages the rotation of the other.

! WARNING! - When replacing, replace both blades on the same blade bar to avoid balance losses. Always check the integrity of the blades for cracks or tears and always replace damaged blades.

1. To remove a blade (1), grasp it firmly and undo the central screw (2).

To assemble a blade, tighten the screws (2) with a torque wrench set to 45-55 Nm.



4.5.2 Sharpening and balancing the blades

! WARNING! - Always wear protective gloves when handling the blades and protect eyes when sharpening.

NOTE A badly sharpened blade causes grass to become yellow; if not balanced, excessive vibration can be caused during cutting.

IMPORTANT Each cutting device (blade) (1) consists of a blade holder bar (2) and two cutting blades (3), each of which is connected to the bar by two screws: the external one (4) is used to achieve the actual fastening, while the internal one (5) is a safety element that breaks in the event of violent impacts, safeguarding the integrity of the shaft and hubs. For this reason, it is mandatory to use only original screws, specifically calibrated to perform this function.

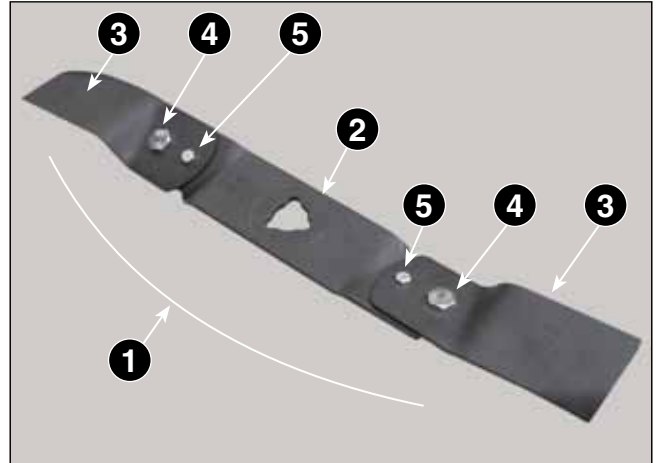

IMPORTANT Sharpening must be performed with the two sharp blades (3) assembled on the bar.

1. Always sharpen both cutting edges of the blades (3) using a medium grade grinder; sharpening must only be done from the rounded side, as shown in the illustration, removing as little material as possible.

IMPORTANT The blades (3) are to be replaced when the cutting edge has worn down to 10 mm.

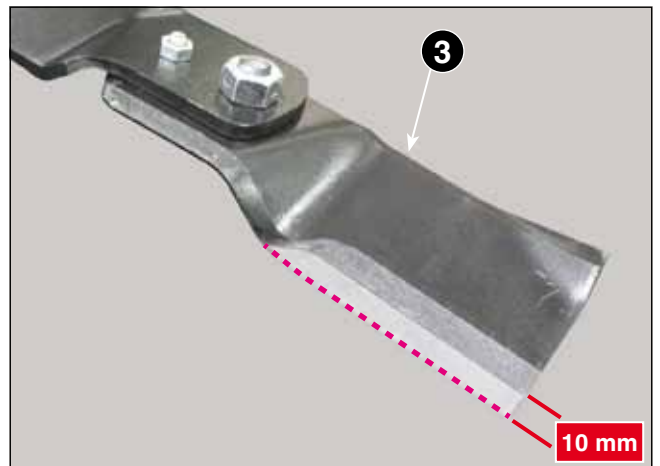

2. Carefully check the blades (3) for breakages, deformations or cracks on both the blade and the fins.

! WARNING! - Impaired blades must always be replaced and never repaired or straightened; to do so would cause damage or injury in the event of breakage during use.



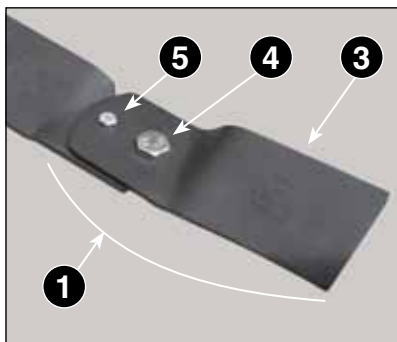

IMPORTANT In case of replacement, both cutting blades (3), supplied in pairs, must always be replaced in order to maintain the balance of the cutting means (1).

! IMPORTANT If the replacement is due to a breakage of one of the cutting blades (3) or of the safety screw (5) caused by an impact, both the screws (4) and (5) must also be replaced with original spare parts.

- Tightening torque settings:
Fastening screws (4) = 35-45 Nm
Fastening screws (5) = 8-12 Nm

3. Using the appropriate equipment, check the balance of the blade (1) to make sure that there is a maximum difference of 2 grams between one side and the other.



4.5.3 Check the alignment of the blade shafts

NOTE Abnormal vibrations that are not caused by the condition or the balancing of the blades, can cause shaft deformation or excessive play of the support bearings.

- Move the cutting deck to the “Maintenance/Washing” position and remove the blades. [👉 4.5.1].

1. Apply a comparator with magnetic support (1) on a flat part of the inside of the cutting deck.
2. Place the probe (2) on the protruding cylindrical part of the shaft (3) and reset the instrument.
3. Rotate the shaft manually. The displacement (and therefore the radial clearance) on the complete turn must not exceed 0.1 mm.

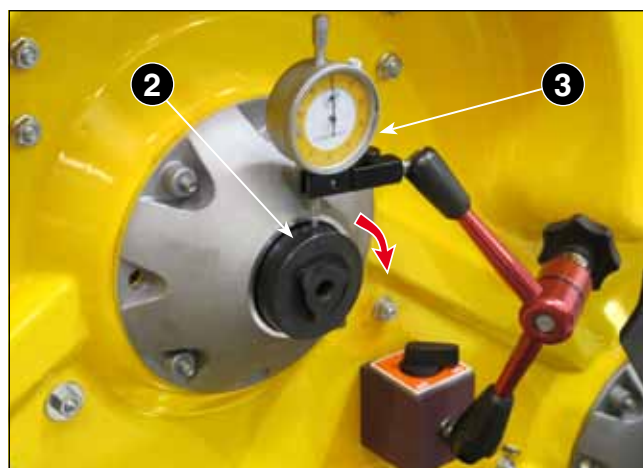

With a higher radial clearance, the entire support / shaft assembly must be replaced [👉 4.5.4].

4.5.4 Replacement of the blade supports and shafts

1. Remove the relevant blade [👉 4.5.1].
2. Undo the four screws (1) and remove the guard (2).



- **In the case of intervention on the left blade support:**

3. Loosen the four screws (3) enough to allow the left pulley axle to move (4) and remove the left belt (5) from the central part of the pulley (4).
4. Undo the screw (6) and remove the pulley (4).

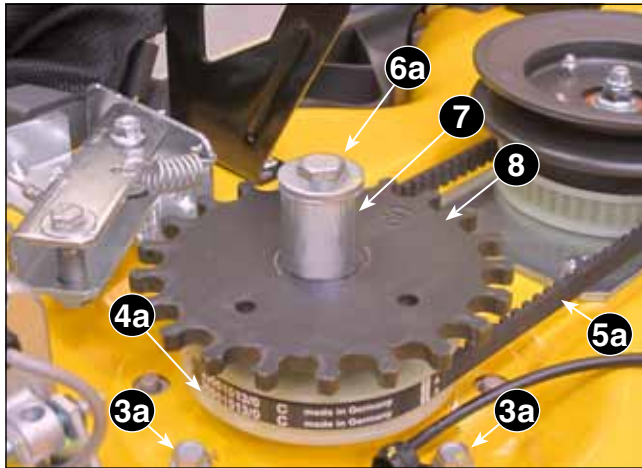
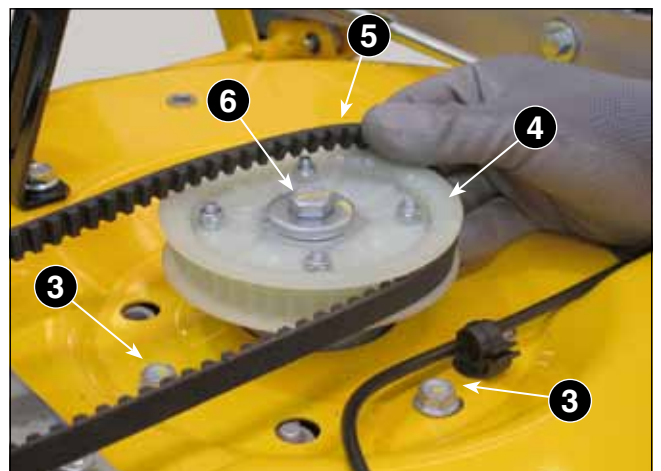

- **In the case of intervention on the right blade support:**

- 3a. Loosen the four screws (3a) enough to allow the right pulley axle to move (4a) and remove the right belt (5a) from the central part of the pulley (4a).
- 4a. Undo the screw (6a) and remove the spacer (7), the crown (8) and the pulley (4a).

5. Fully undo the four screws (3-3a) fastening each support (9-left) or (10-right) and remove it from inside the cutting deck.

IMPORTANT *The supports, each complete with shaft and bearings, are available as spare parts for two different assemblies:*

- Short shaft on pulley side = Left support (9).
- Long shaft on pulley side = Right support (10).

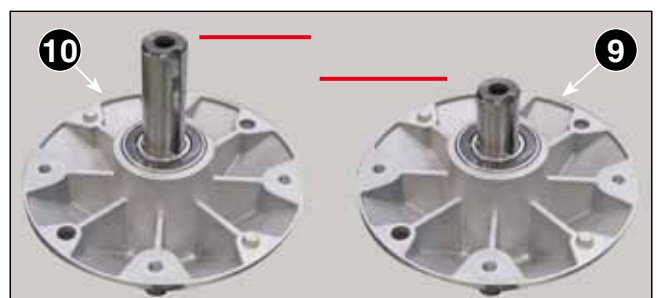

NOTE *The bearings are of the airtight shielded type and do not require lubrication.*

IMPORTANT *The replacement of the shaft or of the bearings is an operation NOT foreseen by the Manufacturer and therefore it must NEVER be proposed or performed autonomously by the Support Centres.*

When mounting, reverse the operations described above, taking care to:

- position the two centring pegs (13) in the respective holes provided on the support surface;
- tighten the screws (6) or (6a) with a torque wrench set to 22-28 Nm.

After reassembling the pulleys and belts, check the orientation of the pulleys and adjust the tension of the belts [👉 4.3.2], from 6 to 9.

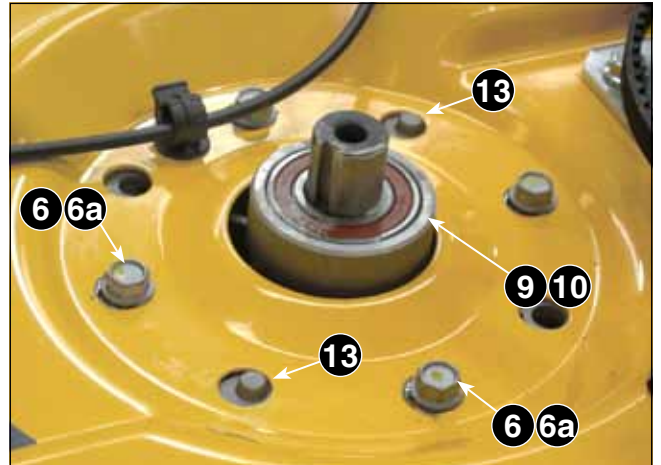

After completing the controls, tighten the screws (3) or (3a) with a torque wrench set to 22-28 Nm.

4.6 REPLACING THE HANDLE CABLES

4.6.1 General information

Using the two front handles allows the plate to be tilted to the "Maintenance / Washing" position, keeping it balanced and raised.

NOTE *The control cable replacement and adjustment operations are common to both handles, taking into account that:*

- *the left handle controls the right arm, with the cable connected under the right pulley;*
- *the right handle controls the left arm, with the cable connected under the left pulley.*

4.6.2 Replacing the cable

1. Remove the upper casing and the pulley from the side required [👉 4.5.4] from 1 to 4.
2. Remove the casing (1), lifting it from the front.

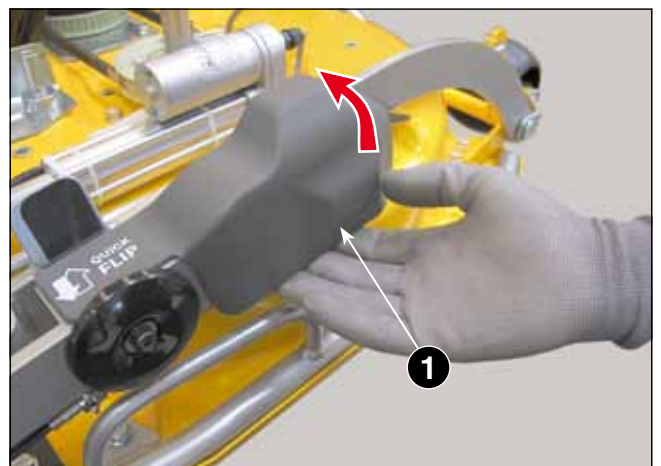

3. Disconnect the spring (2) from the cam (3), remove the cable gland (4) by extracting it from its seat using a pair of pliers and free the upper end of the cable (5).

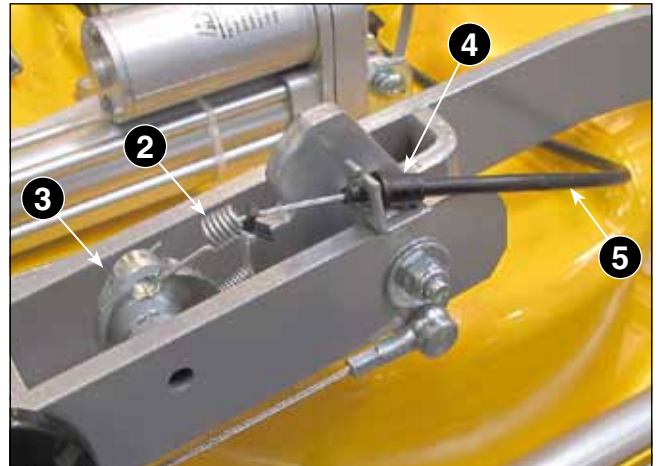

4. Free the cable (5) from the cable clamp (6).

5. When the cable is loose (5), release the handle (8) barrel end of the terminal (7) remove the cable gland (9) using a pair of pliers.

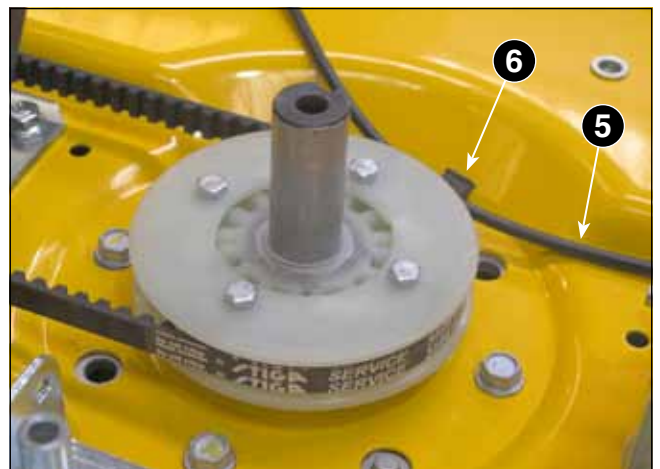

6. Insert the new cable (5) by threading it through the hole in the frame, from the side opposite the handle, respecting the path indicated in the diagram.

7. Restore the connection with the handle (8) and reconnect the cable (5) to the respective cable glands and cable gland (6).

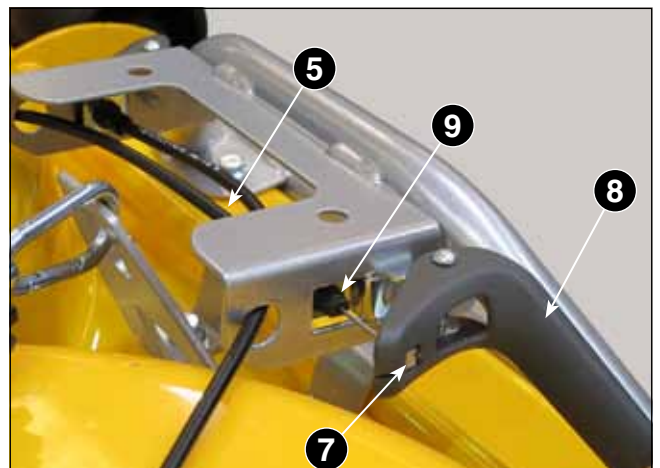

8. Check that the levers and locking system are working correctly.

! WARNING! - *The correct functionality of the system is of fundamental importance to guarantee the operator's safety when accessing the lower part of the cutting deck.*

9. Reassemble the pulleys and the casing [👉 [4.5.4](#)], from 4 to 1.

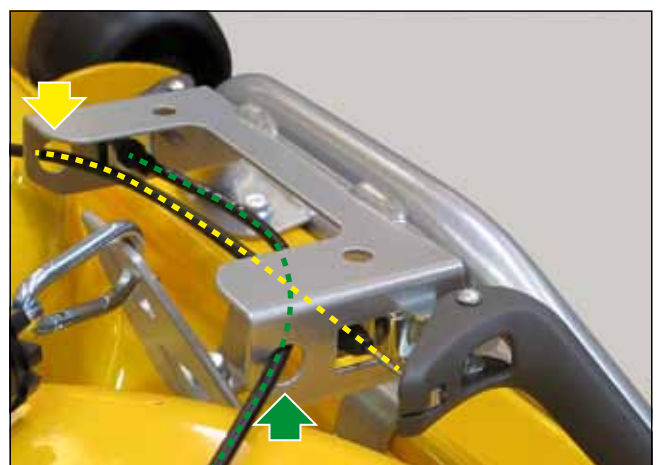

4.7 FRONT WHEELS

4.7.1 General information

The front wheels of the cutting deck are fastened to the frame; if there is excessive radial clearance between the wheel and the support, the internal bushings must be replaced.

4.7.2 Replacement of the bushings

- Move the cutting deck to the "Maintenance / Washing" position to allow removal of the wheels.

⚠ WARNING! - *Ensure the stability of the cutting deck (and the machine if the equipment has not been removed) before proceeding with these operations.*

1. Unscrew the nut (1) and remove the wheel (2).

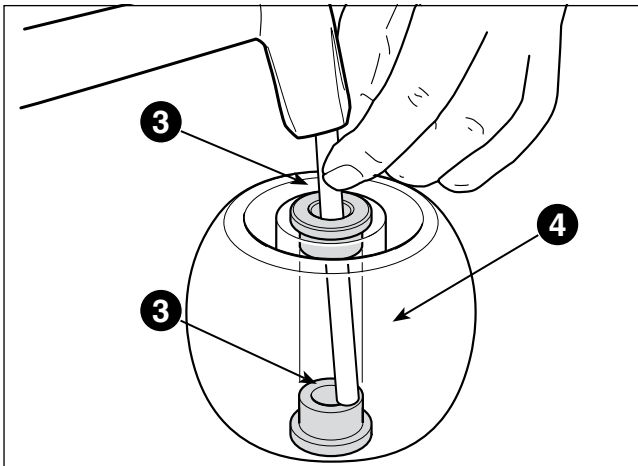
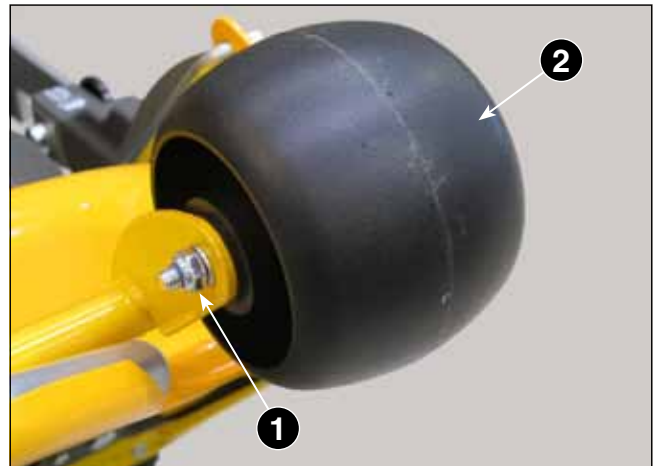

2. Remove the bushings (3) by hitting it from the inside of the hub with a round bar (4) 8 ÷ 10 mm in diameter.

IMPORTANT *Always replace both hub bushings.*

3. Reassemble all the parts following the indicated sequence.

4. Tighten the nut (1) using a torque wrench set to 45-50 Nm.

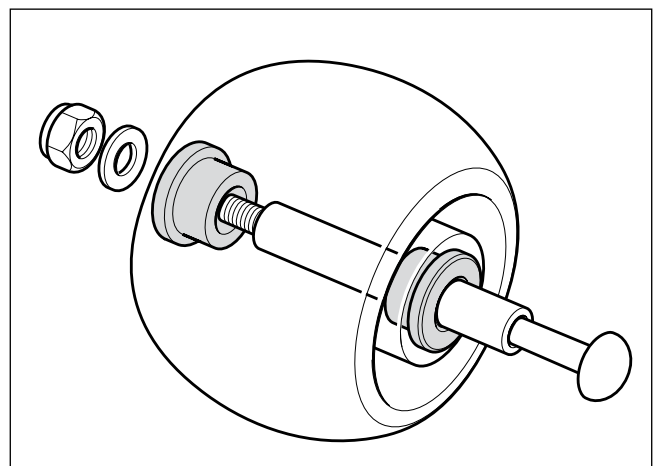

4.8 GENERAL MAINTENANCE

4.8.1 Routine maintenance chart

Object	Frequency Operating hours/months		Related topic
	First time	Next time	
1. Safety checks	5/-	100/12	<ul style="list-style-type: none"> • Safety measures to be adopted [👉 2.1.2]
2. Check all fasteners	5/-	100/12	<ul style="list-style-type: none"> • Tightening torques [👉 2.1.5]
3. Control checks	5/-	100/12	<ul style="list-style-type: none"> • Locking device function check [👉 4.4.2] • Cutting height adjustment function check
4. Transmission belt check	5/-	100/12	<ul style="list-style-type: none"> • Check for initial signs of breakage • Replacement of the control belt [👉 4.3.1] • Replacement of the blade connection belt [👉 4.3.2]
5. Check the condition of the cutting-means	5/-	100/12	<ul style="list-style-type: none"> • Sharpening and balancing the blades [👉 4.5.2] • Check the alignment of the blade shafts [👉 4.5.3]
6. Lubrication of moving parts	During each maintenance operation		<ul style="list-style-type: none"> • Lubrication [👉 4.8.2]
7. General cleaning and inspection	During each maintenance operation		<ul style="list-style-type: none"> • Wash cycle [👉 4.8.3]

4.8.2 Lubrication

Standard practice requires that all moving parts are always well lubricated, making sure that there are no interruptions in the actuation of the various mechanisms.

In addition, the following interventions should be carried out:

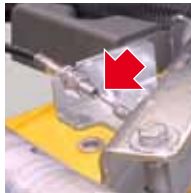
Frequency	Intervention	Lubricant
100 hours or seasonal	Lubrication inside the cable terminals and smooth sliding test  	Oil

4.8.3 Washing and cleaning

Washing the inside of the cutting decks must be carried out with the plate in the "Maintenance/Washing" position, using a water jet only.

IMPORTANT *Never use high pressure jets of water. This could damage the electrical components. Only use water and a brush with non-metallic bristles.*

When the washing is finished, lower the cutting deck, engage the blades and allow them to run for at least 2 minutes, to allow the water to drain from the bearings and rotating parts.

If wear and tear has caused scratching or removal of paint, touch-up the area when it is perfectly clean and dry.

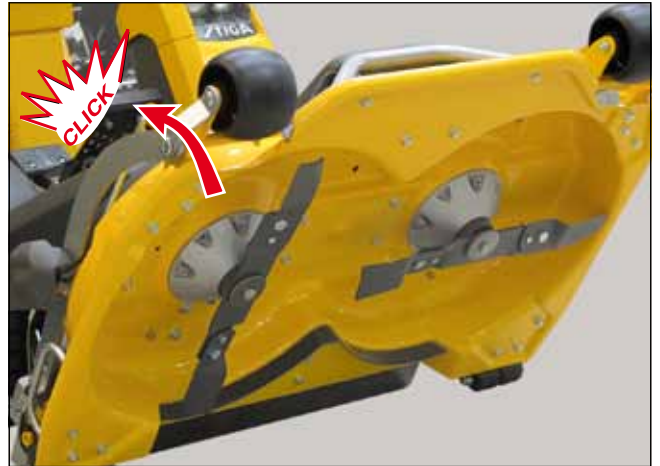

5 - MAINTENANCE (100 Combi 3 EL QF)

Summary

5.1	TROUBLESHOOTING	39
5.2	REPLACING OF GUARDS	40
5.2.1	Replacing the belt guard canvas	40
5.2.2	Replacement of the intermediate guard.....	42
5.3	REPLACING THE BELTS	44
5.3.1	Replacement of the control belt.....	44
5.3.2	Replacing the blade connecting belt	44
5.4	REPLACING AND REGULATING THE LOCKING DEVICE.....	46
5.4.1	General information.....	46
5.4.2	Replacing the locking device and adjusting the cable	46
5.5	BLADES AND SHAFT SUPPORTS.....	49
5.5.1	Removing and reassembling the blades.....	49
5.5.2	Sharpening and balancing the blades	50
5.5.3	Check the alignment of the blade shafts.....	51
5.5.4	Replacement of the blade supports and shafts	52
5.6	REPLACING THE HANDLE CABLES	53
5.6.1	General information.....	53
5.6.2	Replacing the cable.....	53
5.7	FRONT WHEELS	55
5.7.1	General information.....	55
5.7.2	Replacement of the bushings.....	55
5.8	GENERAL MAINTENANCE	56
5.8.1	Routine maintenance chart	56
5.8.2	Lubrication	56
5.8.3	Washing and cleaning	57

5.1 TROUBLESHOOTING

NOTA *The table below provides a guide on how to identify the origin of an anomaly and which section of the Manual deals with such aspects.*

Problem	Probable cause	Solution
1. Worn belt protection canvas	Wear and/or contacts with other elements	Replacement of the belt protection canvas [5.2.1]
2. Damaged belt protection	Contact with other elements	Replacement of intermediate protection [5.2.2]
3. The cutting means do not engage or do not stop promptly when they are disengaged	Wear/breakage of the control belt	Replacement of the control belt [5.3.1]
	Wear/breakage of the blade connection belt	Replacement of the blade connection belt [5.3.2]

Problem	Probable cause	Solution
4. The blade locking device has been triggered with the blades still rotating	• Malfunction of the locking devices	Replacement of the locking device and adjustment of the cable [👉 5.4.2]
	Cable breakage	
5. The blades rotate in the maintenance/wash position	Cable not adjusted	Replacement of the locking device and adjustment of the cable [👉 5.4.2]
	Cable breakage	
6. Abnormal vibration and / or irregular cutting	Loose parts.	Tighten all fastening devices Tightening torque [👉 2.1.5]
	Damaged cutting means.	Sharpening and balancing the blades [👉 5.5.2] Check the alignment of the blade shafts [👉 5.5.3]
7. No cutting height adjustment	Electric motor malfunction	Check electric connection Replace the electric motor
8. Swivel wheels locked	Worn parts	Replace worn parts
	Impacts with foreign parts	Replacement of bushings [👉 5.7.2] Replace damaged parts

5.2 REPLACING OF GUARDS

5.2.1 Replacing the belt guard canvas

⚠ WARNING! - *The integrity of the belt guard canvas is an essential condition for the safety of the machine and equipment. Always replace the canvas at the first signs of wear or tear.*

- Remove the cutting deck from the machine, following the following procedures in reverse order:
 - Disconnect the PTO belt. [👉 3.3.2] from 3 to 1.
 - Remove all mechanical and electrical connections. [👉 3.3.1] from 8 to 1.

- Release the two positioning cables (1) from the lower frame (2) of the belt guard, connecting each terminal to its designated seat taking care not to drop them inside the casing underneath.

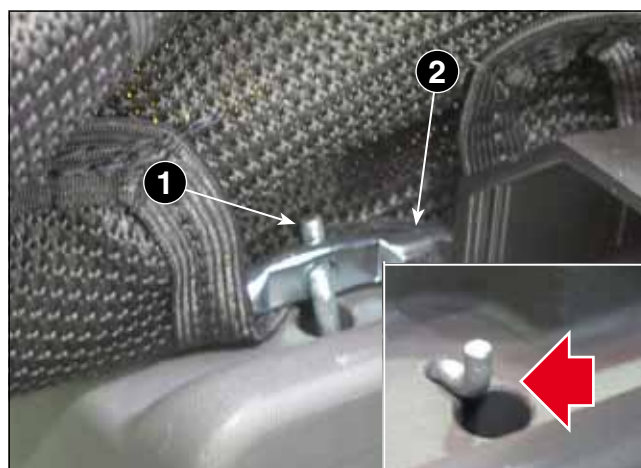

3. Undo the two screws (3) that fasten the canvas belt guard (6) protection supports (4) on the frame (5) to the intermediate guard (7).

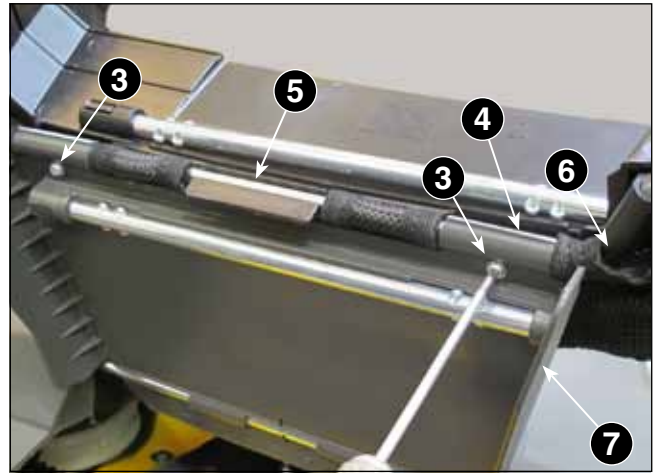

4. Rotate the outer side of the supports (4) to release the frame (5) and remove the machine canvas guard (6).

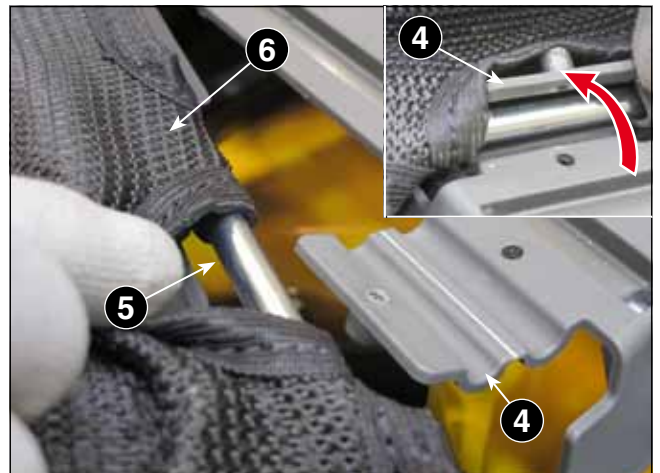

5. Release all plastic profiles (8) that fasten the canvas (6) to the frame (5).

6. From the upper part of the guard, extract the two elastic eyelets (9) from their respective seats (10).



7. Using a suitable pair of pliers, release the retaining tabs (11) on the inside and remove one of the two forks (12).

8. Remove the canvas from the frame.

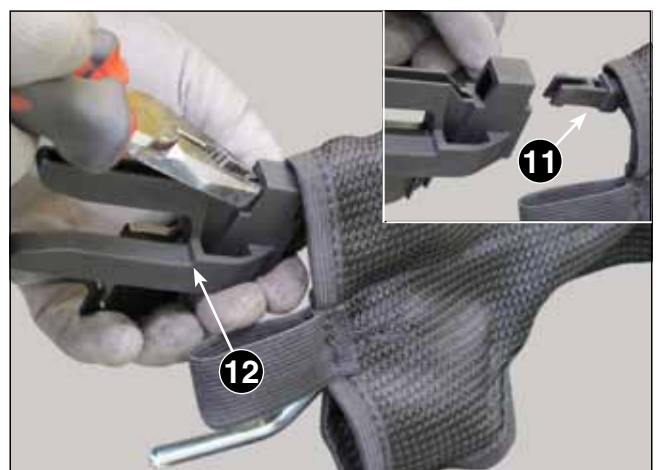

Reassemble the new canvas and fasten the guard following the above procedures in reverse order.

Before tightening on the two support (4) screws (3), make sure that the plastic tab (13) of the canvas guard remains inside the perimeter of the intermediate guard (7).

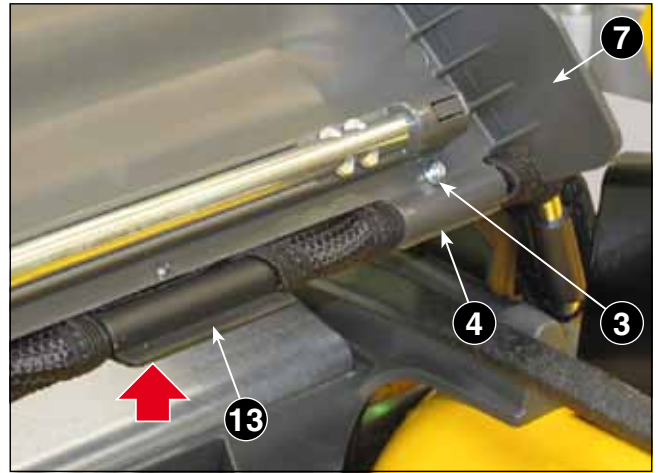
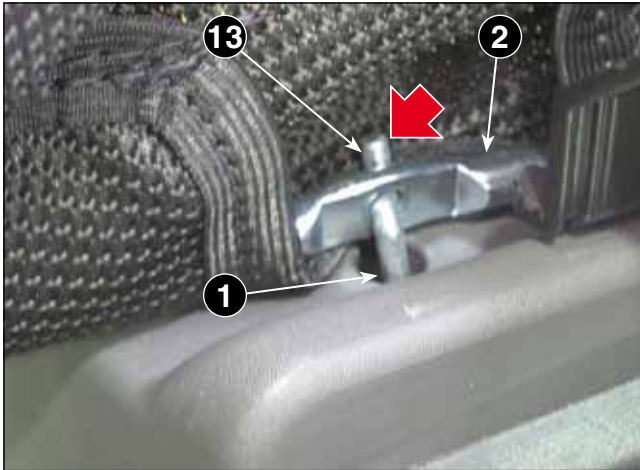

When reconnecting the cables (1) to the frame (2), make sure that the two terminals (13) are inside with respect to the frame.

5.2.2 Replacement of the intermediate guard

1. Remove the canvas guard [👉 5.2.1] from 1 to 4.

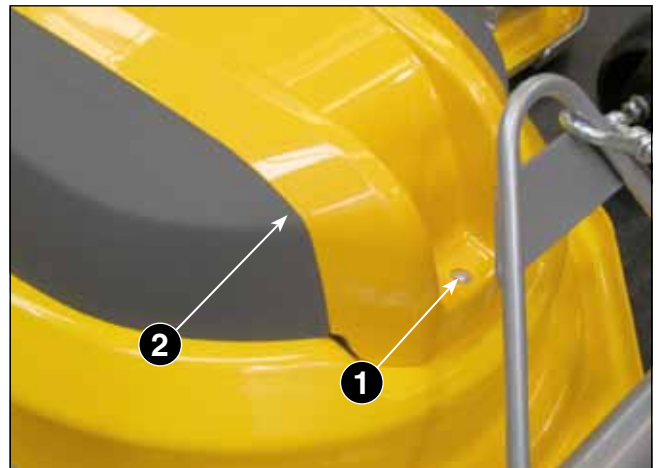
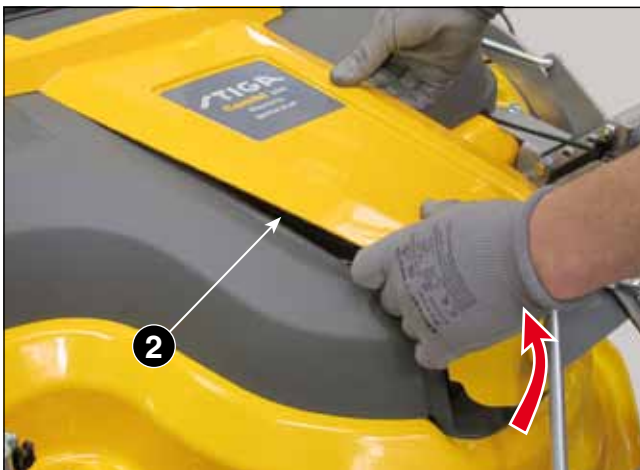

2. Undo the screw (1) and remove the protection (2) by lifting it from the front section.

3. Remove the intermediate guard (3) from the two seats (4) in the rear part of the casing.

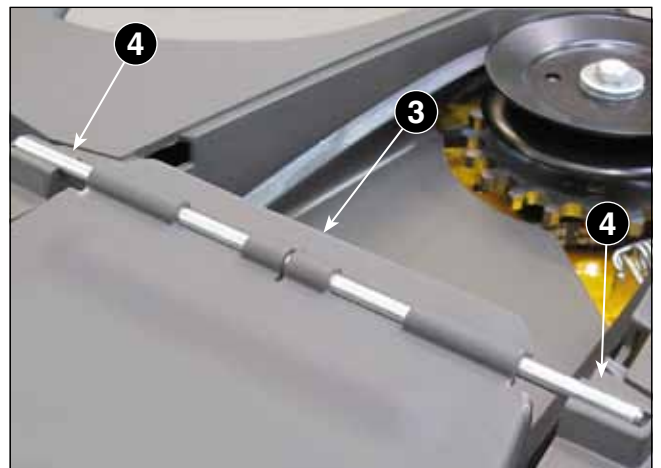

4. If only the plastic part of the guard is being replaced, the two pins must be recovered and reassembled on the new guard:

- Using a screwdriver, remove the central snap ring (5) and followed by the front pin (6).
- From the outside of the guard, press the tab (7) located on the left side with a screwdriver and, keeping it pressed, use a second screwdriver on the right side to push the rear pin (8) to the left, until it can be removed.

IMPORTANT *The function of the rear pin (8) is to prevent accidental sliding of the belt on the internal surface of the guard and therefore must always be reinstated if a guard is replaced.*

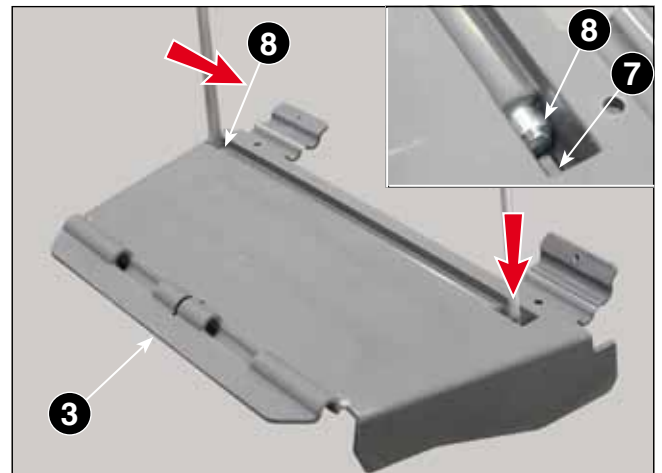
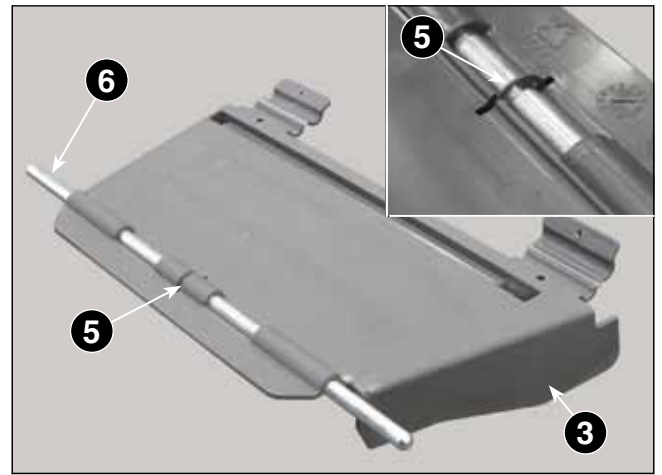

5. Assemble the rear pin (8) by first inserting one end into the left seat and then sliding it to the right until the internal tab (7) clicks into place.

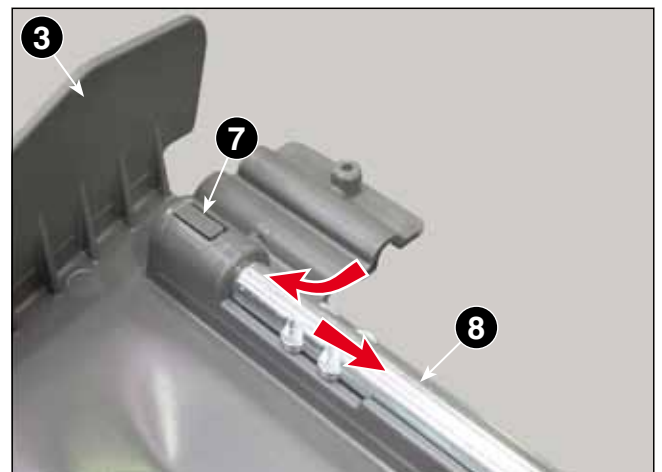

Reassemble the new guard following the above procedures in reverse order, taking care to:

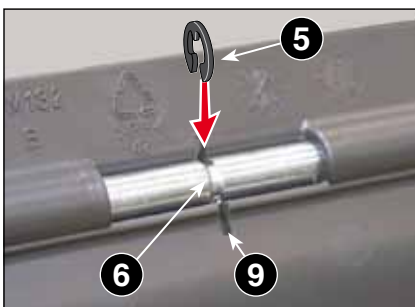

- Align the opening (9) in the intermediate guard with the groove on the pin (6) and reassemble the snap ring (5), making sure that it remains fully inserted in its seat.

- Reassemble the guard (2) making sure all fastening fins (10) click into their respective housings correctly.

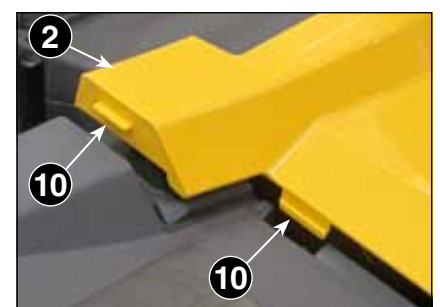

5.3 REPLACING THE BELTS

5.3.1 Replacement of the control belt

NOTE *The replacement of the control belt can be performed without having to remove the cutting deck from the machine.*

- Disconnect the belt from the PTO by following the relative procedure in reverse order. [👉 3.3.2] from 3 to 1.
- Replace the belt following the relative procedure which differs according to the type of cutting deck. [👉 3.1.5] from 1 to 4.

5.3.2 Replacing the blade connecting belt

NOTE *The replacement of the blade connecting belt can be performed both with the cutting deck connected to the machine and also to the bench; this latter solution is however preferable as it allows better accessibility and ease of operation.*

The following operations are easier to perform if the cutting deck is in the minimum height position <<1>>.

If the plate was removed from the machine set at a different height, it is possible to intervene by connecting the electric control connector to an external 12 Volt battery, until the desired working condition is obtained.

- Remove the cutting deck from the machine [👉 3.4.1].
- Remove the canvas guard [👉 5.2.1] from 1 to 3.
- Remove the intermediate guard [👉 5.2.2] from 1 to 5.



1. Undo the screw (1) and remove the protection (2) by lifting it from the front.



2. Free the belt (3) from the pulley (4).

3. Unscrew the front screw (5).

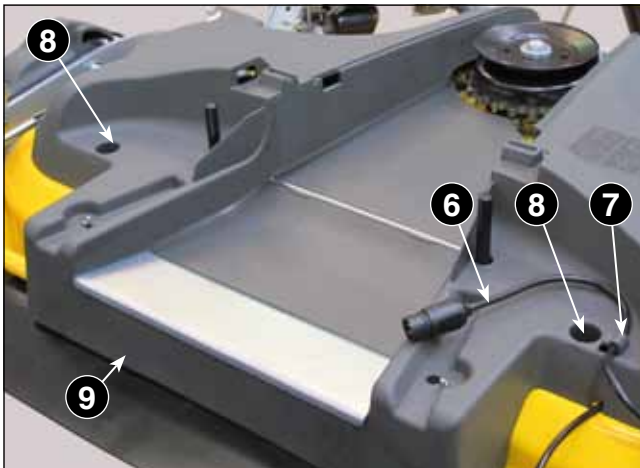

4. Disconnect the cable (6) from the cable clamp (7), undo the two screws (8) and remove the upper guard (9).

5. Release the tension regulator (11) spring (10).

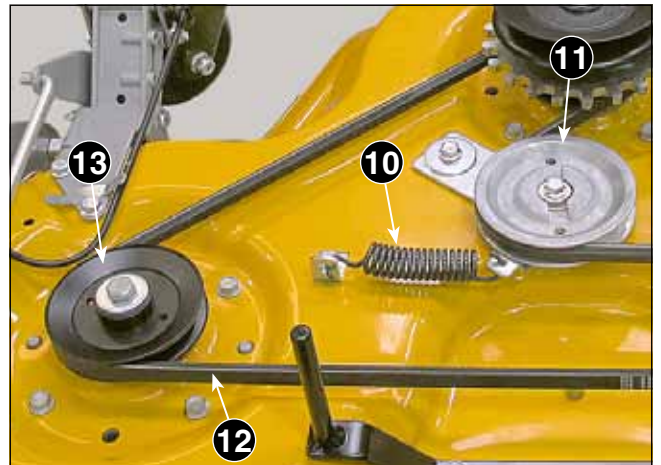

6. First of all free the belt (12) from the left pulley (13).

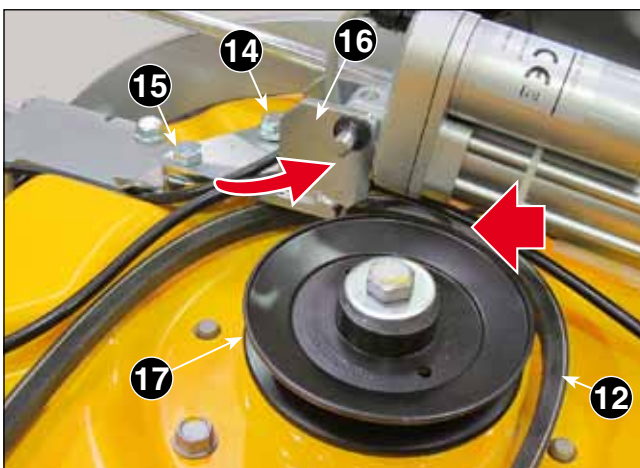

7. Undo the screw (14), loosen the screw (15) and move the support (16) to the side so as to release the belt (12) from the right pulley (17).

8. Remove the belt (12) from the central pulley (18), pulling it out between the teeth of the toothed wheel (19) on the locking device.

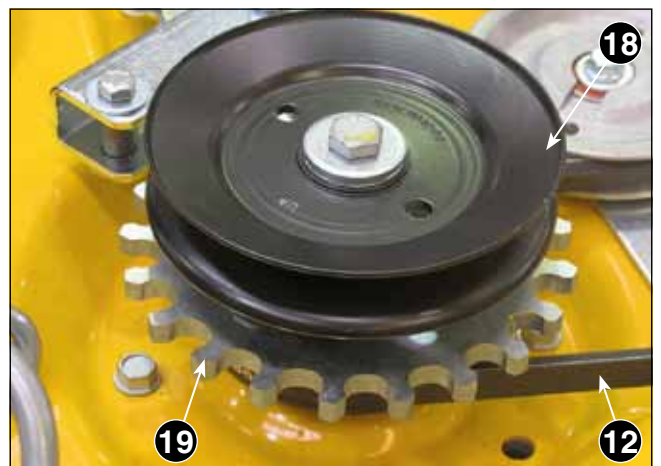

Reassemble the new belt respecting the path indicated in the diagram, following the above procedure in reverse order, taking care to:

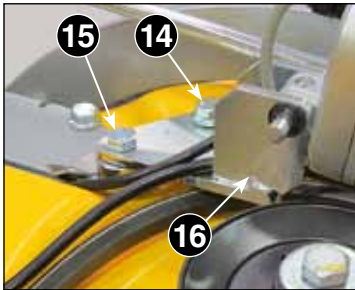

- Reinststate the position of the support (16) and securely tighten the two screws (14) and (15).

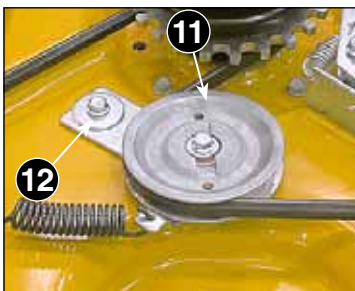

- Lubricate the tensioner lever pin (12) and check that the relative pulley rotates freely.
- Reassemble the guard (2) making sure all fastening fins (20) click into their respective housings correctly.

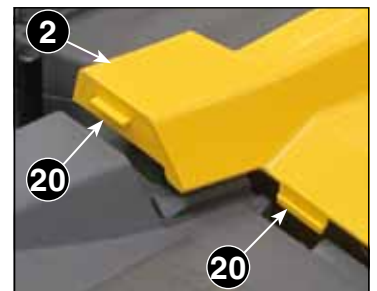

5.4 REPLACING AND REGULATING THE LOCKING DEVICE

5.4.1 General information

The locking device has the purpose of blocking the rotation of the blades if the cutting deck is accidentally moved to the washing position with the blades engaged.

⚠ WARNING! - *This device is an integral part of the safety devices of the machine and therefore must always be kept in perfect working order.*

Repeated interventions on the device, due to incorrect use, can deteriorate the teeth of the toothed wheel and damage the engagement cable.

For this reason, in case of intervention, it is necessary to restore the original factory settings, replacing all the parts shown in the diagram which constitute the essential elements of the mechanism.



5.4.2 Replacing the locking device and adjusting the cable

1. Prepare the cutting deck according to the following procedures:
 - Remove the cutting deck from the machine [👉 3.4.1].
 - Remove the canvas guard [👉 5.2.1] from 1 to 3.
 - Remove the intermediate guard [👉 5.2.2] from 1 to 5.

2. Remove the casings. [ 5.3.2] from 1 to 4.

3. Pull the “Quick Flip” knob (1) to release the right support arm (2) and lift it as far as possible to reduce the tension of the cable.

IMPORTANT Do not lift beyond the stop point so as to avoid anomalies in the coupling system.

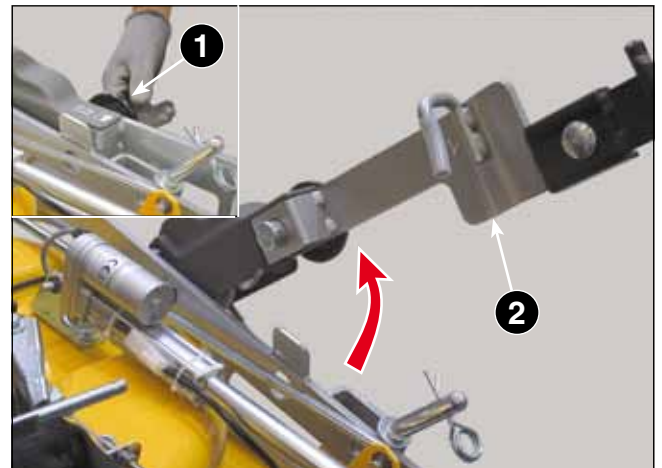

4. Undo the screw (3) and remove the washer (4) and the pulley (5).

5. Remove the toothed wheel (6), using an extractor (7) if difficulties are encountered.

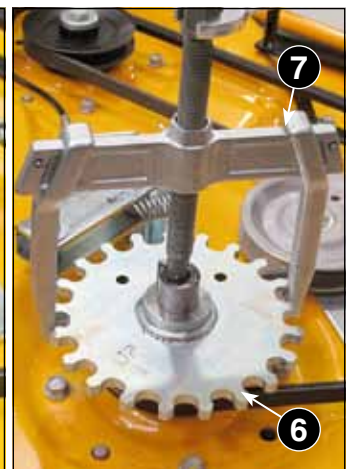

6. Release springs (8) and (9).

7. Loosen the adjuster (10), remove the elastic ring (11), remove the pin (12) and disconnect the cable (13).

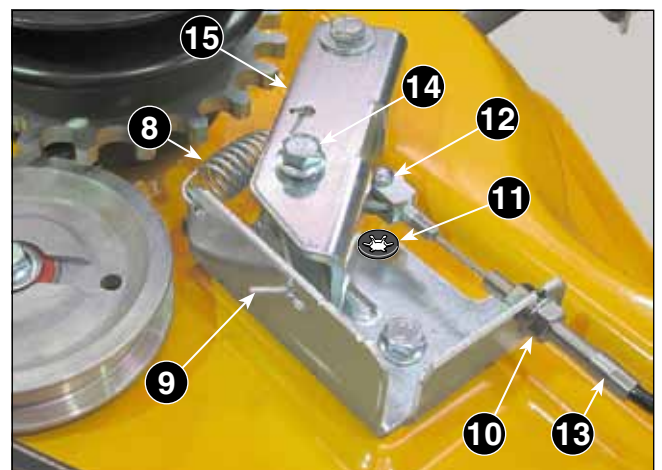

8. Undo the screw (14) and remove the lever (15), leaving the support bracket in place.

9. Lower the right arm (2) and make sure that it is secured in place by the pin on the “Quick Flip” (1) knob.

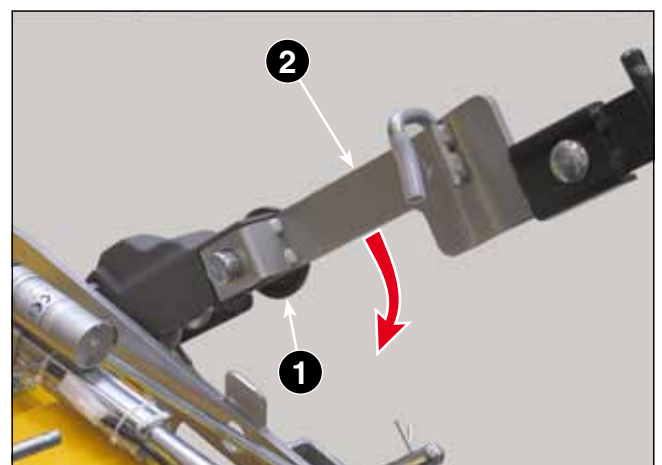

10. Remove the casing (16), lifting it from the front.

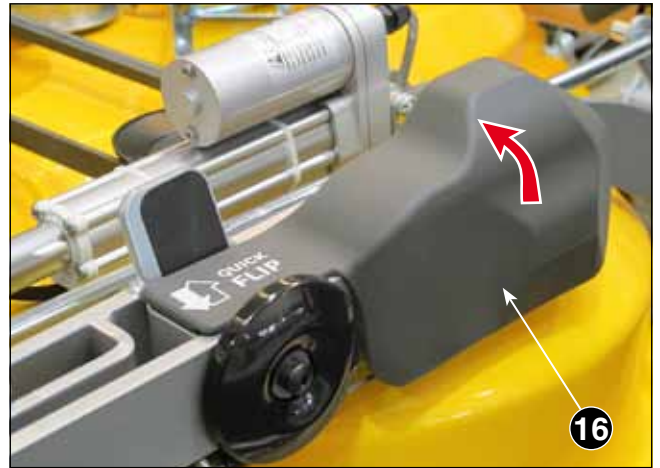

11. Unhook the retainer plate (17) and extract the pin (18) supporting the cable terminal eyelet (19).

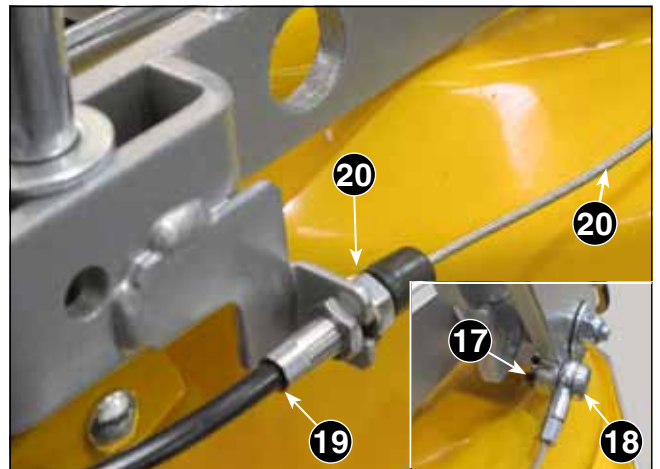

12. Loosen the nut (20) and remove the cable (19).

13. Disassemble all the parts of the leverage system, keeping all the parts highlighted in grey in the drawing, in order to reuse them and reassemble the system with the spare parts used to replace those that are no longer usable for safety reasons.

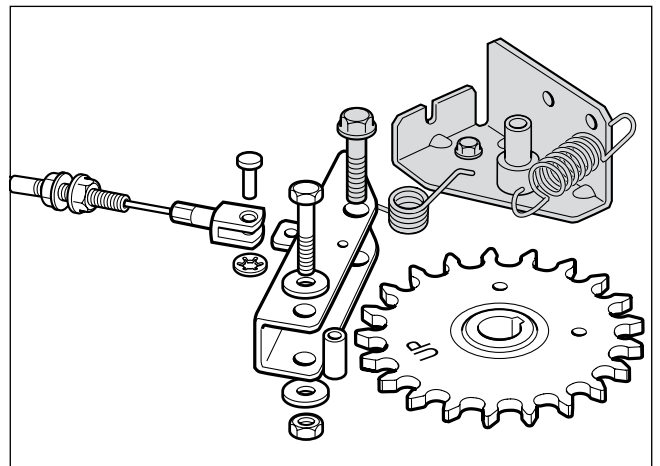

To reassemble, follow the operations from 13 to 4 in the reverse order, taking care to:

- fit the new crown (8) with the «UP» marking facing upwards:
- fit the pulley (5) with the «UP» marking facing upwards:
- tighten the screws (3) using a torque wrench set to 22-28 Nm.

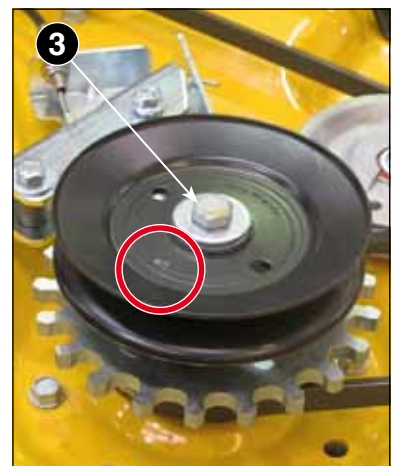

14. With the right arm raised, screw the upper adjuster (20) as far as possible and carefully replace the protection cap (21).

15. Lower the right arm and adjust the lower adjusting nut (10) to obtain a distance of 24-26 mm between the teeth of the crown (6) and the lock roller (22).

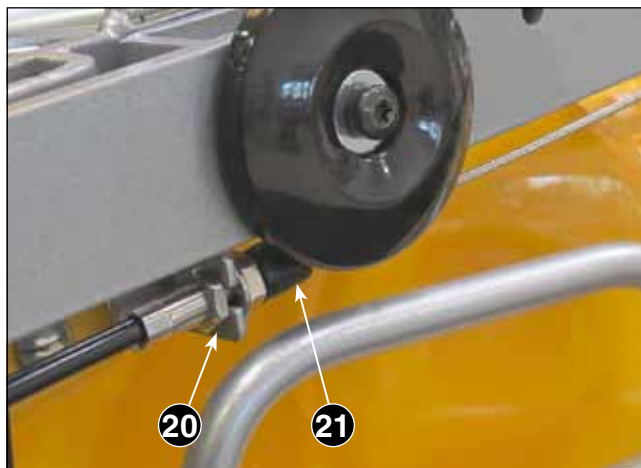

Complete the assembly following the operations from 3 to 1 in the reverse order.

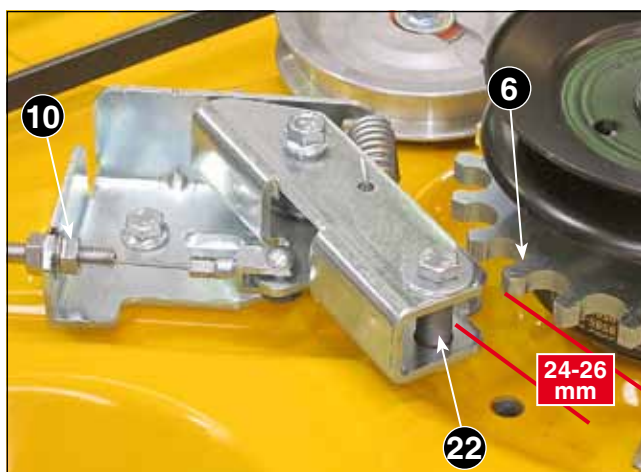

5.5 BLADES AND SHAFT SUPPORTS

5.5.1 Removing and reassembling the blades

NOTE Interventions on the blades can be performed with the cutting deck applied to the machine, adjusted to the minimum cutting height «1» and set to the "Maintenance / Washing" position.

To do so, pull the two "Quick Flip" knobs (1), use the two front handles (2) and lift the cutting deck (3) as far as the release point, making sure it is stable before proceeding with further interventions.

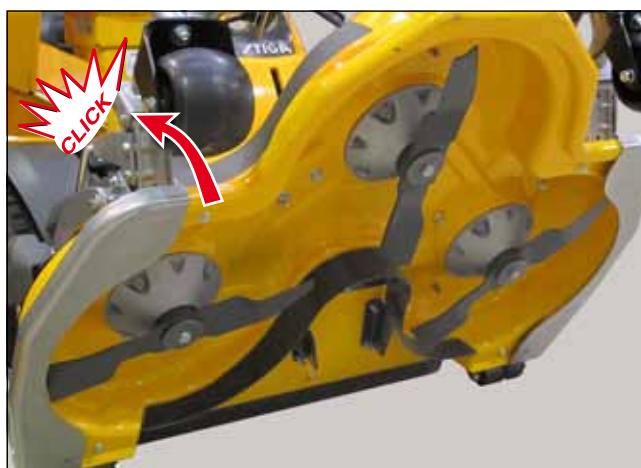

! WARNING! - Apply the machine parking brake and check the stability of the cutting deck before starting any intervention.

! WARNING! - Always wear protective gloves when handling the blades.

! WARNING! - The blades are connected to each other. The rotation of each blade engages the rotation of the other.

! WARNING! - Always check the integrity of the blades for cracks or tears and always replace damaged blades.

1. To remove a blade (1), grasp it firmly and undo the central screw (2).

To assemble a blade, tighten the screws (2) with a torque wrench set to 45-55 Nm.

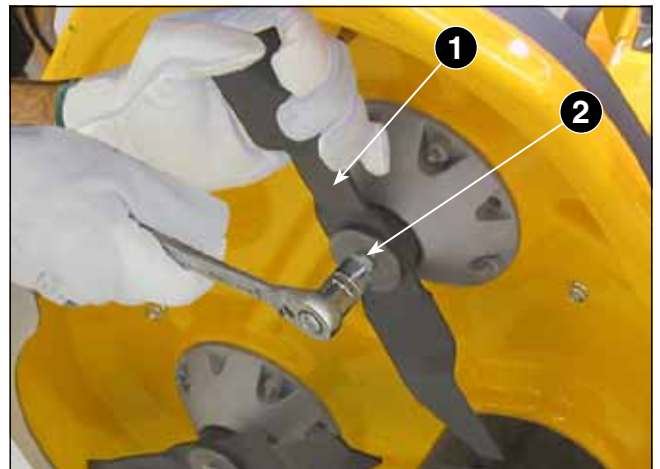

5.5.2 Sharpening and balancing the blades

! WARNING! - Always wear protective gloves when handling the blades and protect eyes when sharpening.

NOTE A badly sharpened blade causes grass to become yellow; if not balanced, excessive vibration can be caused during cutting.

1. Always sharpen both cutting edges of the blades (1) using a medium grade grinder. Sharpening must only be done from the rounded side, as shown in the illustration, removing as little material as possible.

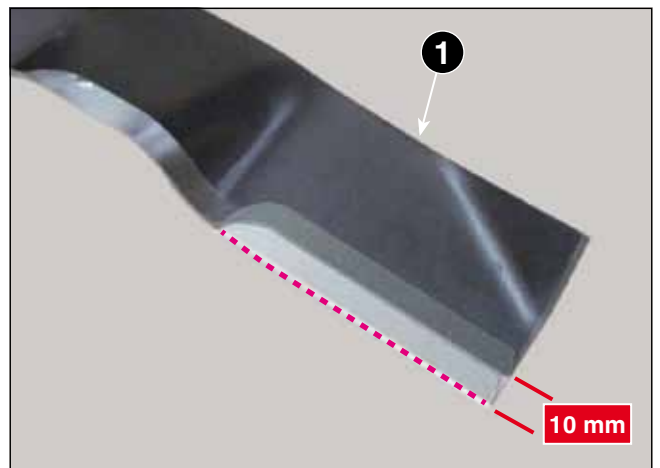

IMPORTANT The blade is to be replaced when the cutting edge has worn down to 10 mm.

2. Carefully check the blades (1) for breakages, deformations or cracks on both the blade and the fins.

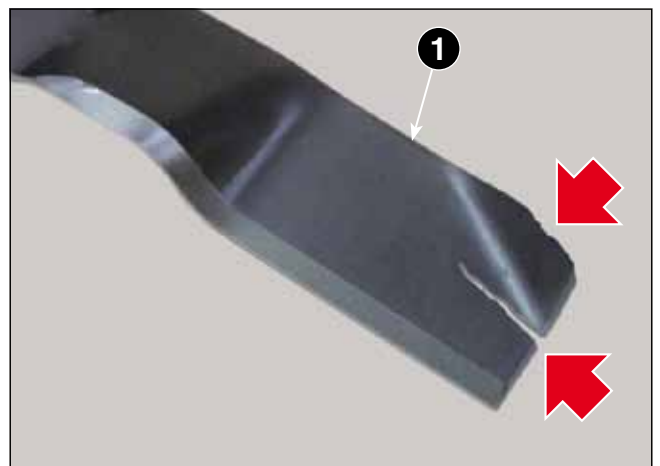

! WARNING! - Impaired blades must always be replaced and never repaired or straightened; to do so would cause damage or injury in the event of breakage during use.

- Using the appropriate equipment, check the balance of the blade (1) to make sure that there is a maximum difference of 2 grams between one side and the other.



5.5.3 Check the alignment of the blade shafts

NOTE *Abnormal vibrations that are not caused by the condition or the balancing of the blades, can cause shaft deformation or excessive play of the support bearings.*

- Move the cutting deck to the “Maintenance/Washing” position and remove the blades. [👉 5.5.1].

- Apply a comparator with magnetic support (1) on a flat part of the inside of the cutting deck.
- Place the probe (2) on the protruding cylindrical part of the shaft (3) and reset the instrument.
- Rotate the shaft manually. The displacement (and therefore the radial clearance) on the complete turn must not exceed 0.1 mm.

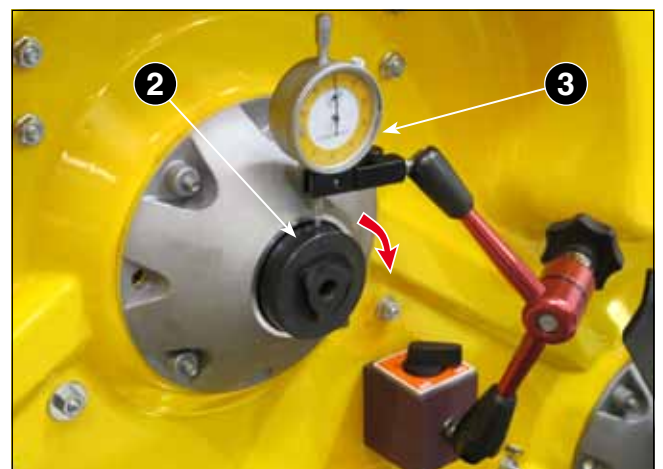

With a higher radial clearance, the entire support / shaft assembly must be replaced [👉 5.5.4].

5.5.4 Replacement of the blade supports and shafts

- Remove the relevant blade [👉 5.5.1].

In the case of intervention on the right blade support:

- Undo the screw (1).
- Undo the screw (2), loosen the screw (3) and move the support (4) to the side so as to release the belt from the right pulley (5).

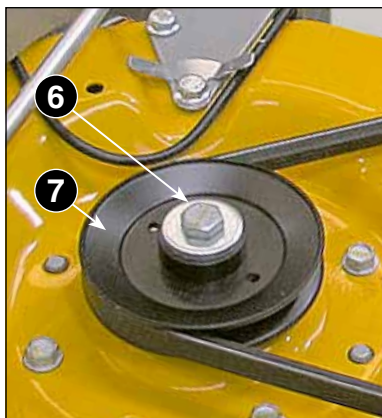
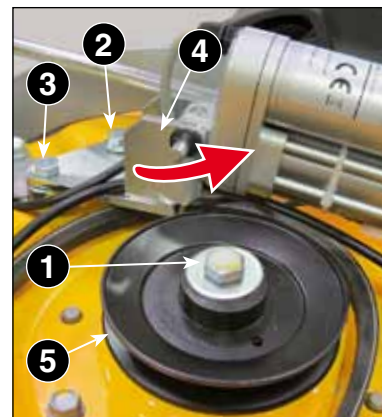

In the case of intervention on the left blade support:

- Unscrew the screw (6) and remove the left pulley (7).

In the case of intervention on central blade support:

- Remove the central pulley and the toothed wheel of the locking device [👉 5.4.2] from 1 to 5.

1. Undo the four screws (11) fastening each support (12) and remove it from inside the cutting deck.

IMPORTANT The supports, each complete with shaft and bearings, are available as spare parts for two different assemblies:

- Short shaft on pulley side = Right or left support (12).
- Long shaft on pulley side = Central support (13).

NOTE The bearings are of the airtight shielded type and do not require lubrication.

IMPORTANT The replacement of the shaft or of the bearings is an operation NOT foreseen by the Manufacturer and therefore it must NEVER be proposed or performed autonomously by the Support Centres.

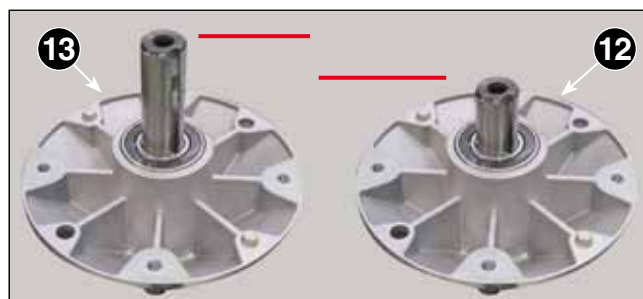
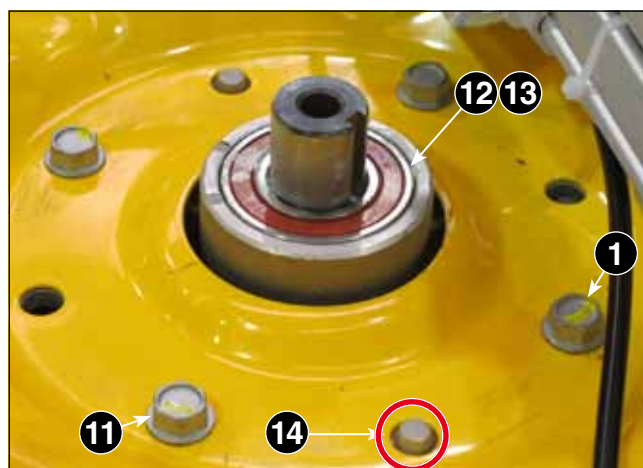

When assembling, take care to position the two centring pegs (14) in the respective holes provided on the support surface.

- Tighten the screws (1) or (7) using a torque wrench set to 25-30 Nm.
- Tighten the screws (5) using a torque wrench set to 22-28 Nm.
- When working on the right blade, reinstate the position of the support (4) and securely tighten the two screws (2) and (3).

5.6 REPLACING THE HANDLE CABLES

5.6.1 General information

Using the two front handles allows the plate to be tilted to the "Maintenance / Washing" position, keeping it balanced and raised.

NOTE The control cable replacement and adjustment operations are common to both handles, taking into account that:

- the right handle controls the right arm,
- the left handle controls the left arm.

5.6.2 Replacing the cable

NOTE Replacing the cable is easier with the cutting deck set at maximum height.

1. Remove the two upper casings [ 5.3.2], from 1 to 4.
2. Remove the casing (1), lifting it from the front.
3. Disconnect the spring (2) from the cam (3), remove the cable gland (4) by extracting it from its seat using a pair of pliers and free the upper end of the cable (5).

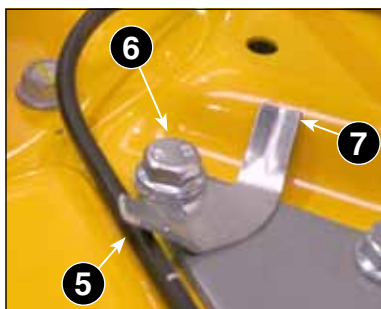
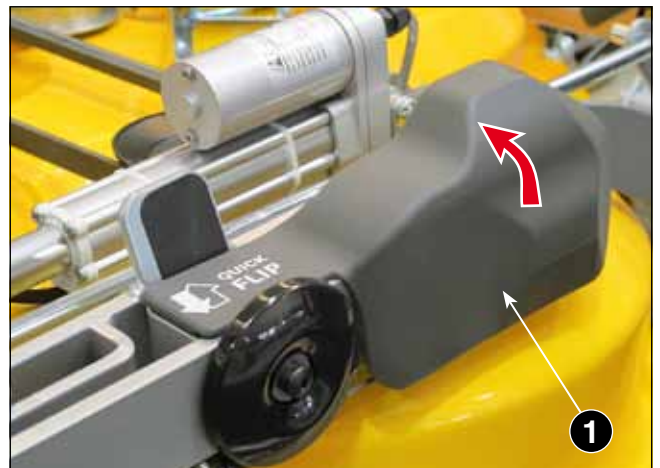

4. Loosen the screw (6) or (6a) to remove the cable (5) from the cable clamp plate (7 - left) or (7a - right).

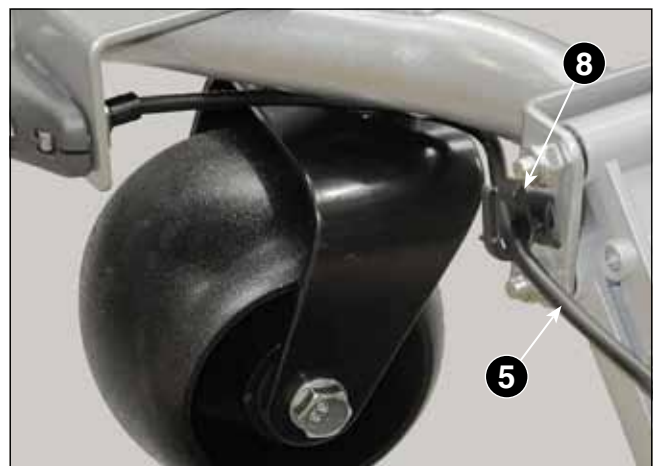
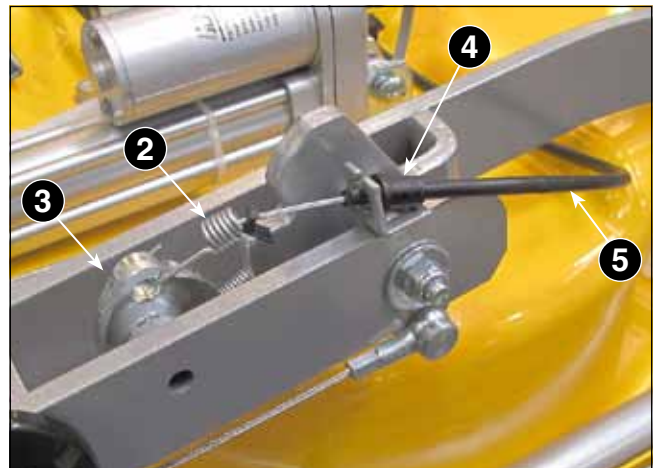
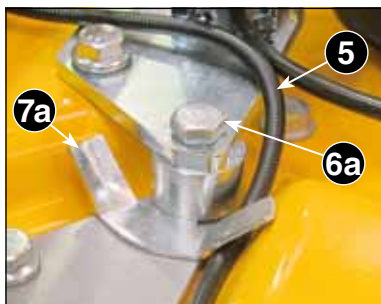

5. Remove the cable (5) from the cable clamp (8).

6. When the cable is loose (5), release the handle (10) barrel end of the terminal (9) remove the cable gland (11) using a pair of pliers and remove the cable (5).

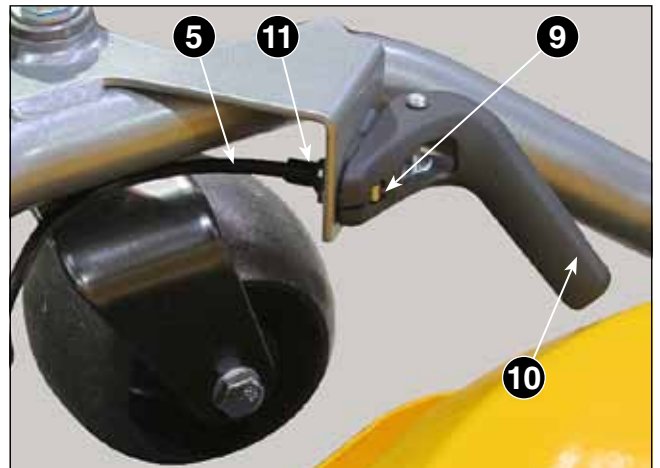

7. Reassemble the new cable (5) following the above procedures in reverse order, taking care to follow the original procedure, paying particular attention to:

- lay the cable (5) above the wheel fork and then attach it to the cable clamp (8);

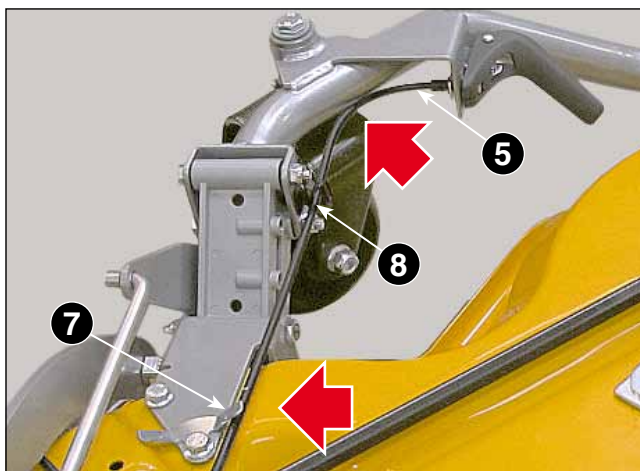

- position the cable (5) inside the cable clamp plates on the left (7) or the right (7a).

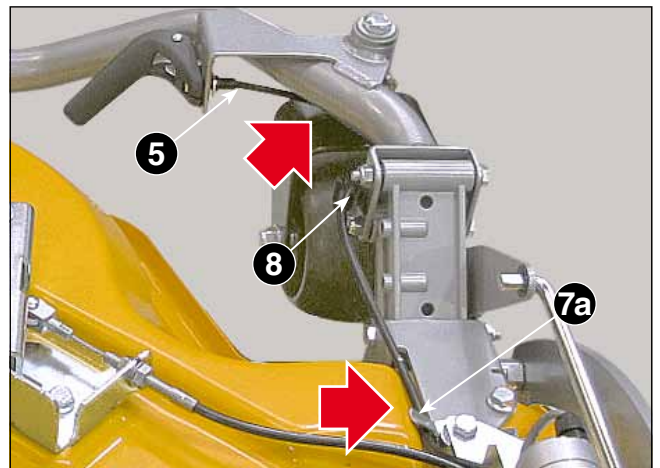

8. Check that the levers and locking system are working correctly.

⚠ WARNING! - *The correct functionality of the system is of fundamental importance to guarantee the operator's safety when accessing the lower part of the cutting deck.*

9. Reassemble the pulleys and casing [👉 5.3.2], from 4 to 1, making sure the cables are threaded through the openings available on the bottom of the casing itself.

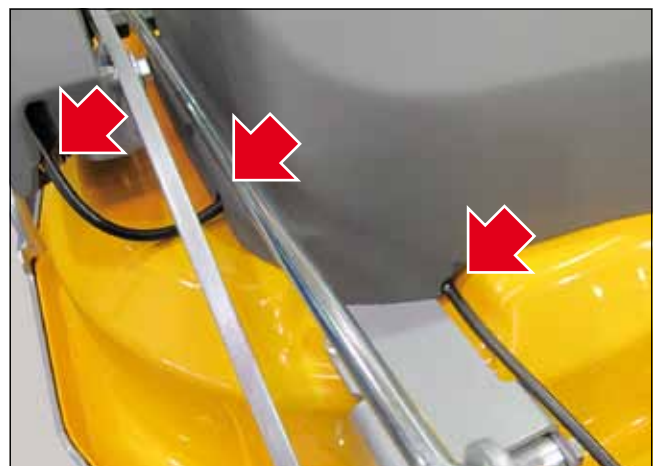

5.7 FRONT WHEELS

5.7.1 General information

The supports of the front cutting deck wheel swivel in relation to the frame; the fork support of each wheel is equipped with a pin whose movement inside the hub is facilitated by the presence of two bushings.

Excessive radial clearance between the wheel support fork and the frame requires the replacement of the bushings, which is carried out according to the following procedure.

5.7.2 Replacement of the bushings

- Move the cutting deck to the "Maintenance/ Washing" position to allow removal of the wheels.

! WARNING! - *Ensure the stability of the cutting deck (and the machine if the equipment has not been removed) before proceeding with these operations.*

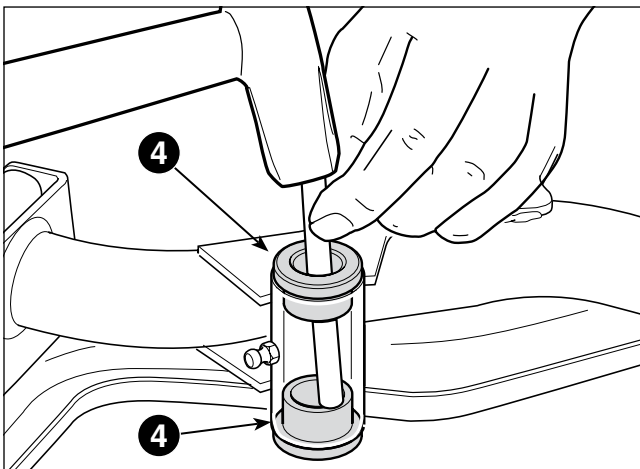

2. Remove the bushings (4) by hitting it from the inside of the hub with a round bar (5) 12 ÷ 15 mm in diameter.

IMPORTANT *Always replace both hub bushings.*

3. Reassemble all the parts following the indicated sequence.
4. Tighten the nut (6) using a torque wrench set to 45-50 Nm.



1. Undo the screw (1) to slide the fork (2) out of the hub (3).

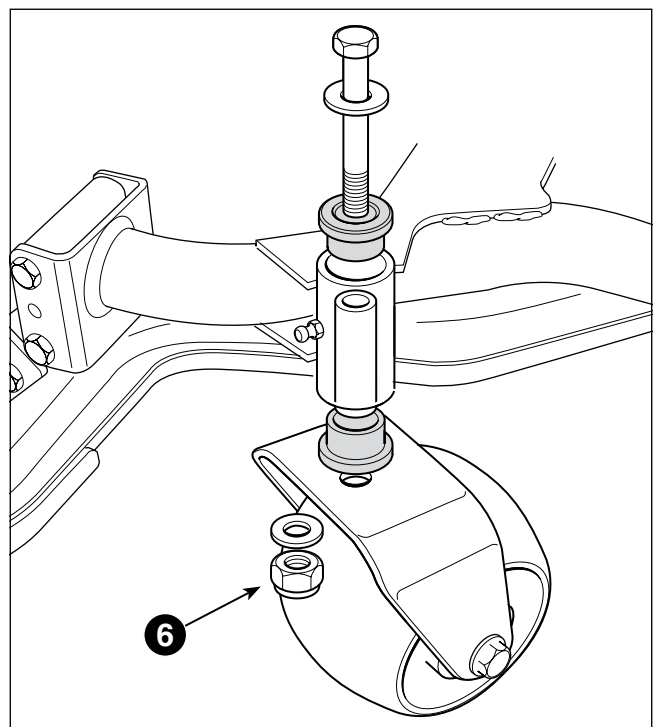

5.8 GENERAL MAINTENANCE



5.8.1 Routine maintenance chart

Object	Frequency Operating hours/months		Related topic
	First time	Next time	
1. Safety checks	5/-	100/12	<ul style="list-style-type: none"> • Safety measures to be adopted [👉 2.1.2]
2. Check all fasteners	5/-	100/12	<ul style="list-style-type: none"> • Tightening torques [👉 2.1.5]
3. Control checks	5/-	100/12	<ul style="list-style-type: none"> • Locking device function check [👉 5.4.2] • Cutting height adjustment function check
4. Transmission belt check	5/-	100/12	<ul style="list-style-type: none"> • Check for initial signs of breakage • Replacement of the control belt [👉 5.3.1] • Replacement of the blade connection belt [👉 5.3.2]
5. Check the condition of the cutting-means	5/-	100/12	<ul style="list-style-type: none"> • Sharpening and balancing the blades [👉 5.5.2] • Check the alignment of the blade shafts [👉 5.5.3]
6. Lubrication of moving parts	During each maintenance operation		<ul style="list-style-type: none"> • Lubrication [👉 5.8.2]
7. General cleaning and inspection	During each maintenance operation		<ul style="list-style-type: none"> • Wash cycle [👉 5.8.3]

5.8.2 Lubrication

Standard practice requires that all moving parts are always well lubricated, making sure that there are no interruptions in the actuation of the various mechanisms.

In addition, the following interventions should be carried out:

Frequency	Intervention	Lubricant
100 hours or seasonal	Lubrication inside the cable terminals and smooth sliding test 	Oil
100 hours or seasonal	Lubrication of the front wheel rods 	Grease
100 hours or seasonal	Lubrication of the front joints 	Oil

Frequency	Intervention		Lubricant
100 hours or seasonal	Lubrication of the tensioner lever pin.		Oil

5.8.3 Washing and cleaning

Washing the inside of the cutting decks must be carried out with the plate in the "Maintenance/Washing" position, using a water jet only.

IMPORTANT *Never use high pressure jets of water. This could damage the electrical components. Only use water and a brush with non-metallic bristles.*

When the washing is finished, lower the cutting deck, engage the blades and allow them to run for at least 2 minutes, to allow the water to drain from the bearings and rotating parts.

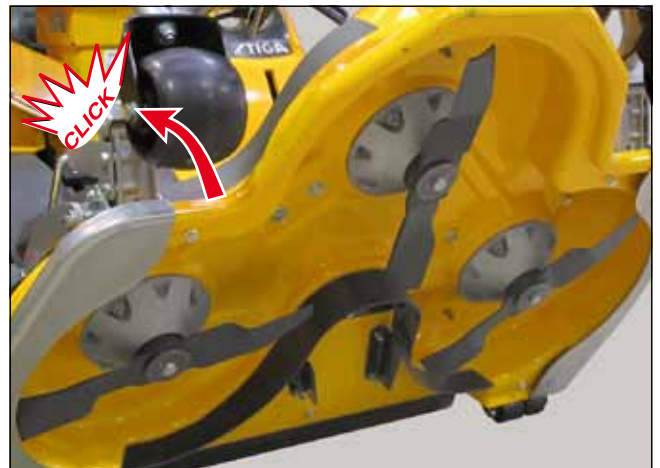

If wear and tear has caused scratching or removal of paint, touch-up the area when it is perfectly clean and dry.

STIGA

STIGA S.p.A - Via del Lavoro, 6 - 31033 Castelfranco Veneto (TV) - Italy
www.stiga.com